

M202DR

200-lb. Capacity OPL Dryer

Standard Features:

- 200-lb. capacity
- 61.20 cu. ft. volume
- 404,000 Btu/hr heat input and 2,600 cfm
- Radial airflow
- Easy-to-load vertical steel doors
- Self-diagnostic microprocessor with patented auto-drying feature
- Easy access to lint compartment
- Available in gas
- Reversing basket
- Four-Point roller support and drive system
- Stainless steel basket with removable panels

Optional Features:

- Stainless steel front and cabinet
- F.S.S. (Fire Suppression System)

OPL



M202DR OPL Dryer

Why Purchase Milnor M202DR?

Engineer Driven Design That is Built to Last

Our dryers showcase an engineer-driven approach to design. Bearings are permanently lubricated on the motor and drive system. There are no chains used; rather, we use V-belts and pulleys for smooth, quiet, and trouble-free operation. Our dryer cabinets are electrostatically powder-painted inside and out, then baked at 420 degrees Fahrenheit before final assembly – ensuring the hardest surface and the longest-lasting finish in the industry.

Rugged Steel Door with Gasketless Door Glass

Our heavy-duty steel door design provides ease of use for loading and unloading utilizing, a counter-balanced pulley system to ensure simple open-and-close operation. A gasket-less door glass panel provides security and durability versus rubber type gaskets.

Easy-to-Read, Multilingual Controls

Milnor continues to apply innovative technology to dryer operation. Our state-of-the-art microprocessor with auto-dry capabilities, easy-to-read LED screens, and our user-friendly multilingual interface position Milnor as a leader in the laundry industry.

Your local Milnor independent authorized distributor



M202DR

M202DR Specifications

Maximum Capacity (Dry Weight)	200 lb	90.72 kg	
Tumbler Diameter	55-5/8"	141.29 cm	
Tumbler Depth	43-1/2"	110.49 cm	
Tumbler Volume	61.20 cu ft	1732.99 L	
Tumbler/Drive Motor	3 hp	2.24 kW	
Blower/Fan Motor	7-1/2 hp	5.59 kW	
Door Opening (Diameter)	40-3/4"	103.50 cm	
Door Sill Height	34-5/8"	87.95 cm	
Water Connection	3/4" - 11.5 NH (North America) 3/4" B.S.P.T. (Outside North America)		
Dryers per 20'/40' Container	3 / 7		
Dryers per 48'/53' Truck	8 / 8		
GAS	Voltage Available	208-575v 3ø 3, 4w 60 Hz	
	Approximate Net Weight	2,100 lb	952.54 kg
	Approximate Shipping Weight	2,166 lb	982.48 kg
	Airflow	2,600 cfm	73.6 cmm
	Heat Input	404,000 Btu/hr	101,874 kcal/hr
	Exhaust Connection (Diameter)	12"	30.48 cm
	Compressed Air Connection	1/4" Quick Connection	
	Compressed Air Volume	4.25 cfh	0.12 cmh
	Inlet Pipe Connection	1" F.N.P.T. (North America) 1-1/2" B.S.P.T. (Outside North America)	

DRYER NOTES:

- * DUCTWORK SIZE VARIES WITH INSTALLATION CONDITIONS.
- * EXHAUST STATIC PRESSURE MUST BE NO LESS THAN 0 AND MUST NOT EXCEED 0.3" (0.74 MB) WATER COLUMN.

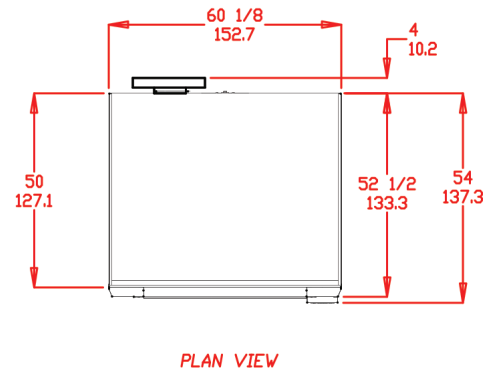
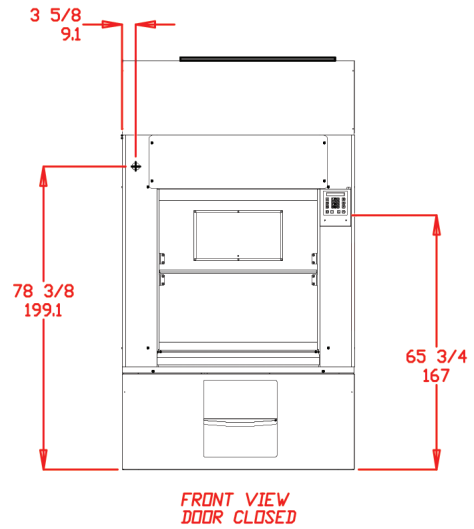
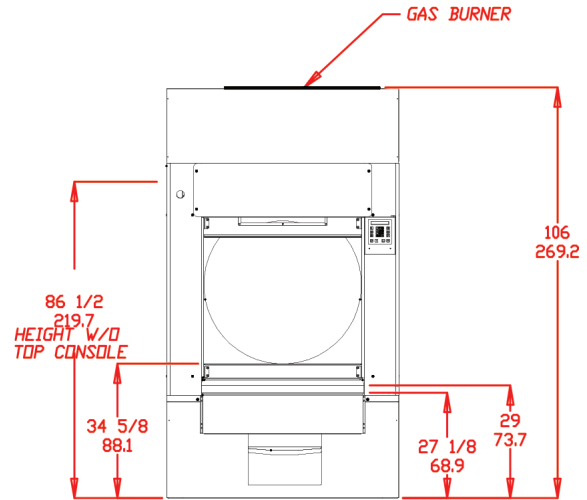

Shaded areas are stated in metric equivalents

7/25/14

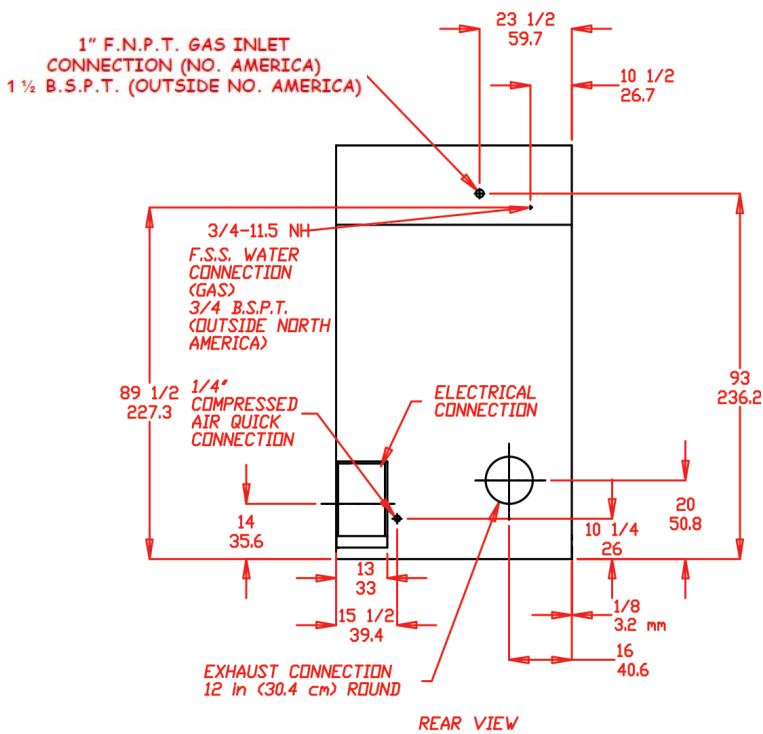

Pellerin Milnor Corporation, PO Box 400, Kenner, LA 70063 USA
Phone 504.712.7656 Toll-Free: 800.469.8780 Fax: 504.468.3094

www.milnor.com

QY180024