

M330C

30-lb x 2 Capacity Coin Dryer

Standard Features:

- 30-lb. x 2 capacity
- 10.1 cu. ft. volume per pocket
- 68,000 btu/hr heat input, 400 cfm. airflow per pocket
- 100% Axial airflow
- Steel door with gasketless glass
- 6" Diameter vent connection per pocket
- 1/2" gas connection per pocket
- Independent electrical connections for each tumbler
- Only 43-7/8" deep for gas and electric
- Single coin drop
- Front serviceable
- Fits through a standard 36" door
- Available in gas, steam and electric heat

Optional Features:

- Stainless Steel Front, Cabinet & Basket
- S.A.F.E. (Sensor Activated Fire Extinguishing System)

Why Purchase M330C?

Engineer Driven Design That is Built to Last

Our dryers showcase Milnor's engineer-driven approach to design. Bearings are permanently lubricated on the motor and drive system. There are no chains used at Milnor; rather, we use V-belts and pulleys for smooth, quiet, and trouble free operation. Our dryer cabinets are electrostatically powder-painted inside and out then baked at 420-degrees fahrenheit before final assembly - ensuring the hardest surface and the longest lasting finish in the industry.

Component Accessibility

The M330C is a dual pocket dryer that offers 98% component accessibility from the front of the tumbler. This feature allows the dryer to be placed against the wall without concern for regular rear maintenance. The M330 has a large lightweight lint drawer that is accessible and easy to clean -- only requiring cleaning once a day. It's fine, stainless steel lint screen is standard.

Rugged Steel Door with Gasketless Door Glass

Our dryer doors are one solid piece of steel with gasketless glass. This eliminates the issue of glass falling out due to wear and tear on rubber gaskets that some manufacturers use to secure their glass. The security and durability that gasketless glass provides is essential to a successful laundromat operation.

Easy-to-Read, Multilingual Controls

We were the first to bring computer operated dryers to the market and today we continue to be a leader in applying technology to dryer operation. Our years of experience along with our accessible design, easy-to-read LCD screens and our user friendly multilingual interface positions Milnor as the pioneer in the laundry industry.

Your local Milnor independent authorized distributor

COIN



M330C Coin Dryer

M330C

M330C Specifications

Maximum Capacity (dry weight) per pocket	30 lb Tumbler	13.60 kg
Diameter	27-1/4" Tumbler Depth	69.2 cm
30" Tumbler Volume per pocket	10.1 cu ft	76.2 cm
Tumbler / Drive Motor per pocket	1 hp / 1/2 hp* Blower /	286.0 L
Fan Motor* per pocket		0.75 kW / 0.37 kW
Door Opening (diameter)	21-1/2"	N/A
		54.6 cm
Door Sill Height top pocket/bottom pocket	52-3/8" / 14-1/4"	133.033 cm / 36.195 cm
Water Connection	3/4"-11.5 NH (North America) 3/4" B.S.P.T. (Outside North America)	
Dryers per 20'/40' Container	14 / 28	
Dryers per 48'/53' Truck	34 / 36	
GAS MODEL	Voltage Available	100-240V 1ø 2w 50/60 Hz
	Approximate Net Weight	793 lb 359.7 kg
	Approximate Shipping Weight	860 lb 390.1 kg
	Airflow per pocket	60 Hz 400 cfm 11.33 cmm 50 Hz 333 cfm 9.44 cmm
	Heat Input per pocket	68,000 Btu/hr 17,135 kcal/hr
	Exhaust Connection (diameter) per pocket	6" 15.24 cm
	Compressed Air Connection	N / A
	Compressed Air Volume	N / A
	Inlet Pipe Connection per pocket	1/2" F.N.P.T. 1/2" B.S.P.T. (CE and Australia Only)
	Voltage Available	208-416V 1,3ø 2,3,4w 50/60 Hz
ELECTRIC MODEL	Approximate Net Weight	793 lb 359.7 kg
	Approximate Shipping Weight	860 lb 390.1 kg
	Airflow per pocket	60 Hz 400 cfm 11.33 cmm 50 Hz 333 cfm 9.44 cmm
	Exhaust Connection (diameter) per pocket	6" 15.24 cm
	Compressed Air Connection	N / A
	Compressed Air Volume	N / A
	Oven Size	kW Btu/hr kcal/hr 15 51,228 12,910
	Voltage Available	100-240V 1ø 2w 50/60 Hz
	Approximate Net Weight	837 lb 379.7 kg
	Approximate Shipping Weight	884 lb 401.0 kg
STEAM MODEL*	Airflow	60 Hz 400 cfm 11.33 cmm 50 Hz 333 cfm 9.44 cmm
	Steam Consumption per pocket	101 lb/hr 45.8 kg/hr
	Operating Steam Pressure	125 psi max 8.62 bar
	Exhaust Connection (diameter) per pocket	6" 15.24 cm
	Compressed Air Connection per pocket	1/8" F.N.P.T.
	Compressed Air Volume	0.5 cfh 0.014 cmh
	Boiler Horsepower (Normal Load) per pocket	2.9 Bhp
	Supply Connection per pocket	1" N.P.T. (Female)
Return Connection per pocket	3/4" N.P.T. (Female)	

* Dryer must be provided with clean, dry and regulated 80 psi +/- 10 psi (5.51 bar +/- 0.69 bar) air supply.

REV 02/28/16

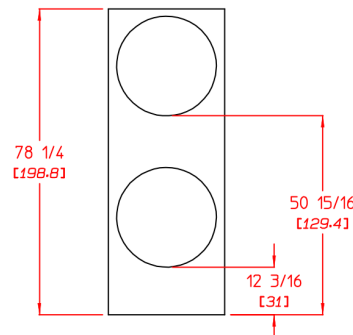
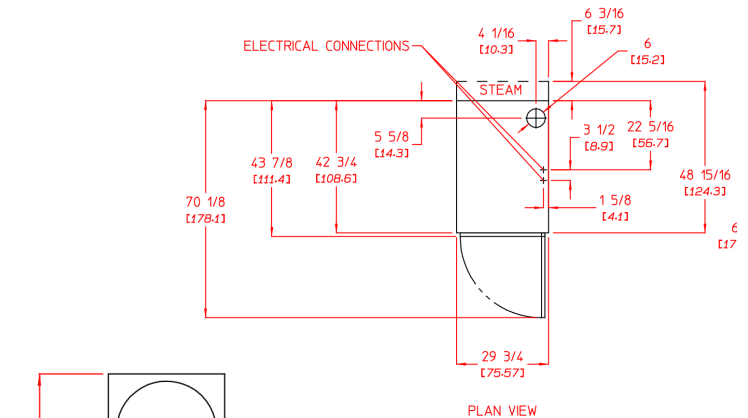
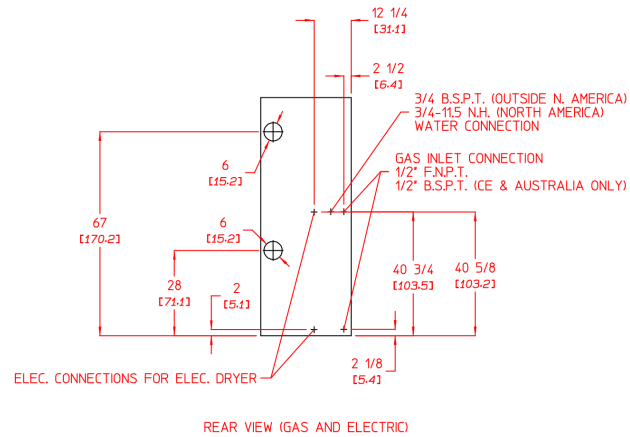
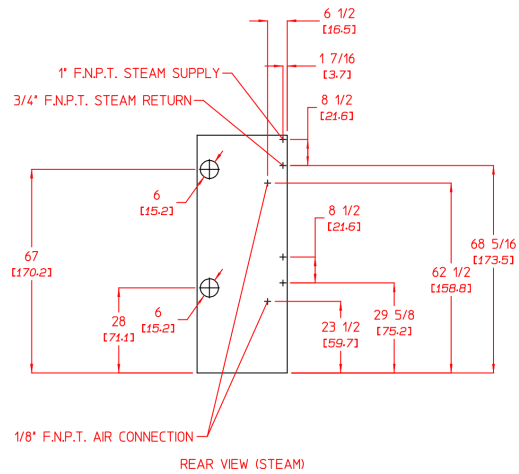

Pellerin Milnor Corporation, P.O. Box 400, Kenner, LA 70063 USA,
Phone 504.712.7656 Toll Free: 800.469.8780 Fax: 504.468.3094

www.milnor.com