

48040 F7Z

275 LB. (125KG) CAPACITY
SUSPENDED WASHER-EXTRACTOR

SPECIFICATION SHEET

FRONT VIEW

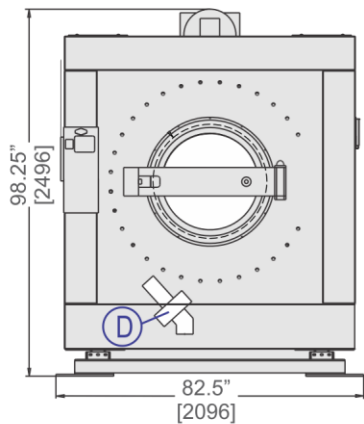

RIGHT VIEW

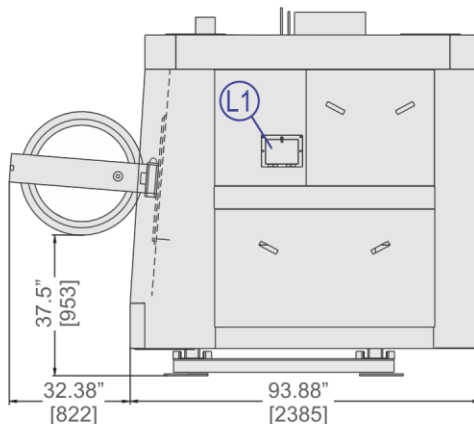

REAR VIEW

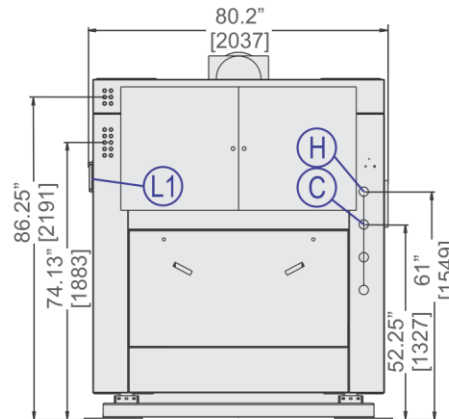

FOUNDATION VIEW

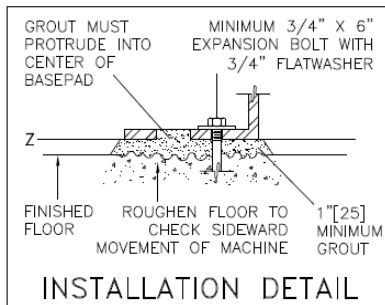
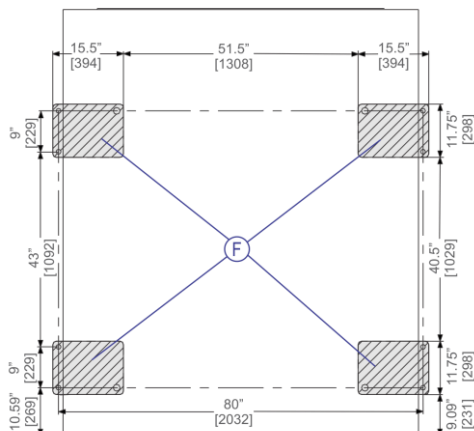

LEGEND

C	Cold water inlet, 1.5" (38 mm) GHT
D	Drain to sewer, 4" pipe connection
F	Foundation pads
H	Hot water inlet, 1.5" (38 mm) GHT
L1	Standard soap chute

MECHANICAL SPECIFICATIONS

Capacity – lb (kg)	275 (125)
Cylinder Diameter x Depth – in (mm)	48 x 40 (1219x1016)
Door Opening – in (mm)	30.5 (775)
Cylinder Volume – cu. ft. (L)	42 (1188)
Machine Dimensions (W x D x H) – in (mm)	82.5 x 93.88 x 98.25 (2096x2385x2496)
Shipping Dimensions (W x D x H) – in (mm)	87 x 124 x 102.4 (2210x3150x2600)
Motor – HP (kW)	25 (18.6)
Wash Speeds – RPM	20-40
Distribution Speed – RPM	66
Extraction Speeds – RPM	200-664
Extraction G-Force	300
Water Pressure <i>(Required)</i> – psi (bar)	10-75 (0.69-5.17)
Water Valve Cv Rating at 72°F (22°C)	49.1 (185.9)
Static Weight – lb (kg) ◇	11,244 (5100)
Max. Dynamic Load RMS - lb (kg) ◇	1459.68 (662.10)
Frequency (Hz)	11.07

ELECTRICAL SPECIFICATIONS

Voltage	Running Amps	Fuse (Amps)	Circuit Breaker (Amps)
208/3/60	62	FRN75	75
220/3/50-60	60	FRN75	75
240/3/60	59	FRN75	75
380/3/50-60	33	FRS50	50
400/3/50	33	FRS50	50
415/3/50	33	FRS50	50
480/3/50	32	FRS50	50
600→480/3/60	32	FRS50	50

See Fuse and Wire Size manual MAEFUSE1BE for safety information.

▼ See dimensional drawing for complete details.

◇ It is the sole responsibility of the owner/user to assure that the floor and/or any other supporting structure exceeds not only all applicable building codes, but also that the floor and/or any other supporting structure for each washer-extractor or group of washer-extractors has sufficient strength and rigidity (i.e., a natural or resonant frequency many times greater than the rotational machine speed with a reasonable factory of safety) to support the weight of all the fully loaded machine(s) including the weight of the water and goods, and including the published 360° rotating sinusoidal RMS forces that are transmitted by the machine(s). Contact the factory for additional machine data for use by a structural engineer.



48040 F7Z

275 LB. (125KG) CAPACITY

SUSPENDED WASHER-EXTRACTOR

SPECIFICATION SHEET

Standard Features:

- MilTouch™ programmable controller
- RinSave® water saving technology
- Color graphic display
- Single-motor inverter drive
- Air-operated valves
- Programmable overnight bath soak
- Programmable water temperature for each bath
- Suspension system
- Tapered roller bearings
- Large cylinder perforations
- Ten (10) liquid chemical injection ports
- Control reads in English/second language



Optional Features:

- 5 compartment flushing supply injector

Why Purchase Milnor?

- MilTouch™ touch screen control, utilizing resistive touch screen technology and full VGA resolution, has a clear and informative display which shows current machine status info including total formula time and time elapsed. Formulas can be developed on a PC, saved to USB external memory and uploaded with a screen touch. Controller also provides intuitive fault diagnosis and relevant troubleshooting suggestions. **BENEFIT: Fewer operator errors.**
- 300-G high extract provides excellent moisture removal. Lower extract speeds are available for uniforms, delicate textiles and blended fabrics. **BENEFIT: Better extraction saves dryer fuel.**
- 10 liquid chemical ports and signals. **BENEFIT: Promotes consistency and allows flexibility.**
- Larger cylinder perforated-area generates *better wash quality, better rinsing and better extraction.* **BENEFIT: Better extraction saves dryer fuel.**
- Faster process times reduce fabric wear, promoting *longer linen life!* **BENEFIT: Saves linen replacement costs.**
- Superior product support through local, highly-skilled dealers. **BENEFIT: Faster repairs mean less downtime.**



Safe chemical injection



Superior cylinder design



SmoothCoil™ Suspension

Contact Milnor for your local, authorized dealer:

Pellerin Milnor Corporation
PO Box 400 • Kenner, LA 70063
t: 504-467-9591

