

# 30015 V8Z

## 40 lb. (18 kg) Capacity Rigid-Mount Washer-Extractor Specification Sheet



[milnor.com](http://milnor.com)



### STANDARD FEATURES:

- RinSave® water saving technology
- 7 speeds (2 wash, 1 distribution, 1 RinSave, 3 extract)
- MilTouch™ touch screen controller
- Single-motor inverter drive
- Tall, lifting ribs
- Tapered roller bearings
- High M.A.F. (Mechanical Action Factor)
- Large cylinder perforations
- Fresh-water flushing chemical manifold
- Auto tension V-belt drive
- Six (6) liquid chemical injection ports
- Control is configurable to display language of choice
- 5-year limited warranty on frame, cylinder & shell



### OPTIONAL FEATURES:

- Steam
- 3 compartment flushing supply injector
- Prison package

## Why Purchase Milnor?

**BENEFIT: Saves water, energy and time.** RinSave® water saver in conjunction with large cylinder perforations provides more efficient rinsing.

**BENEFIT: Saves labor.** Larger cylinder volume than most competitive, similar-sized washer-extractors provides greater productivity. More linen washed per day, or fewer hours required to process.

**BENEFIT: Saves linen replacement costs.** Faster process times reduce fabric wear, promoting longer linen life!

**BENEFIT: Greater mechanical action (M.A.F.) leads to better wash quality.** Greater cylinder perforated area, tall rib construction and precise cylinder speeds generate better cleaning results, better rinsing, and better extraction.

**BENEFIT: Better extraction saves dryer fuel.** High extract provides excellent moisture removal. Lower extract speeds are available for uniforms, delicate textiles and blended fabrics.

**BENEFIT: Fewer operator errors.** MilTouch™ touch screen control, utilizing resistive touch screen technology and full VGA resolution, has a clear and informative display which shows current machine status info including total formula time and time elapsed. Formulas can be developed on a PC, saved to USB external memory and uploaded with a screen touch. Controller also provides intuitive fault diagnosis and relevant troubleshooting suggestions.

**BENEFIT: Faster repairs mean less downtime.** Superior product support through local, highly-skilled dealers.



Superior cylinder design



Safe chemical injection



Solid industrial frame

Contact Milnor for your local, authorized dealer:

**PELLERIN MILNOR CORPORATION**

P.O. Box 400, Kenner, LA 70063 • t: 504-467-9591 • [milnorinfo@milnor.com](mailto:milnorinfo@milnor.com)

# 30015 V8Z

## 40 lb. (18 kg) Capacity Rigid-Mount Washer-Extractor Specification Sheet



[milnor.com](http://milnor.com)

### LEGEND

<b>C</b>	Cold water inlet, .75" (19 mm) GHT
<b>D</b>	Drain to sewer, 3" (76 mm) pipe connection
<b>E</b>	Electrical connection
<b>F</b>	Foundation pads
<b>G</b>	Hot water (chemical flushing), 0.75" (19 mm) GHT
<b>H</b>	Hot water inlet, .75" (19 mm) GHT
<b>L1</b>	Soap chute
<b>L2</b>	Liquid supply inlets

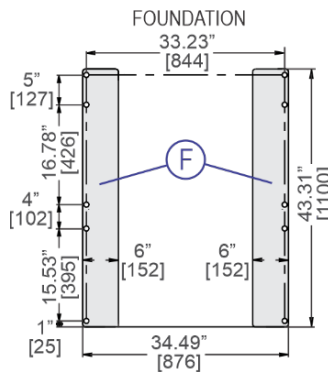
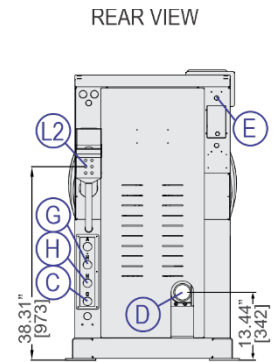
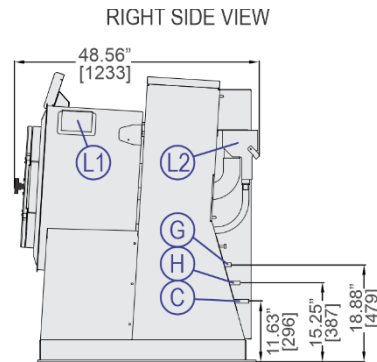
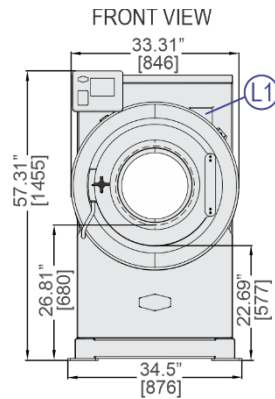

### ANCHORING DETAIL

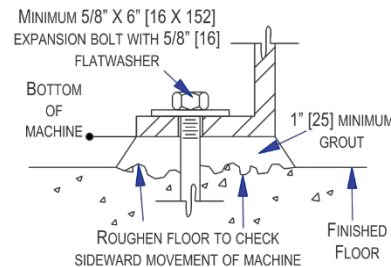

FLOOR REQUIREMENT 12" MINIMUM.

RECOMMENDED



### MECHANICAL SPECIFICATIONS

Capacity – lb. (kg)	40 (18)
Cylinder Diameter x Depth – in. (mm)	30 x 15 (762 x 381)
Cylinder Volume – cu. ft. (L)	6.14 (174)
Door Opening – in. (mm)	15.5 (394)
Machine Dimensions (W x D x H) – in. (mm)	34.5 x 48.6 x 57.31 (876 x 1234 x 1456)
Shipping Dimensions (W x D x H) – in. (mm)	40 x 64 x 63 (1016 x 1625 x 1600)
Motor – HP (kW)	5 (3.72)
Wash Speed – RPM	30-46
Distribution Speed – RPM	99
Extraction Speed – RPM	200-840
Extraction G-Force – for balanced loads	300
Static Weight – lb. (kg)◆	1144 (519)
Max. Dynamic Load RMS – lb. (kg)◆	2168 (983)
Frequency - Hz◆	14
Water Pressure <sup>(Required)</sup> – psi (bar)	10-75 (.68-5.1)
Water Valve - Cv Rating at 72°F (22°C)	10 (37.8)
Minimum Recommended Distance Between Machines – in. (mm)	6 (152)

### ELECTRICAL SPECIFICATIONS

Voltage	Running Amps	Fuse (Amps)	Circuit Breaker (Amps)
220/3/50-60	13	FRN20	20
208, 240/1/60	16, 15	FRN25	25
208, 240/3/60	14, 13	FRN20	20
380/3/50-60	8	FRS15	15
480/3/60	7	FRS15	15

See Fuse and Wire Size manual MAEFUSE1BE for safety information. Contact factory regarding single phase availability.

▲ See dimensional drawing for complete details.

◆ It is the sole responsibility of the owner/user to assure that the floor and/ or any other supporting structure exceeds not only all applicable building codes, but also that the floor and/ or any other supporting structure for each washer-extractor or group of washer-extractors has sufficient strength and rigidity (i.e., a natural or resonant frequency many times greater than the rotational machine speed with a reasonable factory of safety) to support the weight of all the fully loaded machine(s) including the weight of the water and goods, and including the published 360° rotating sinusoidal RMS forces that are transmitted by the machine(s). Contact the factory for additional machine data for use by a structural engineer.

■ Machine bases made from concrete should either be part of a monolithic pour or should be tied into foundation and not isolated from existing floor.