

Published Manual Number/ECN: MPICOSHRAE/2023333A

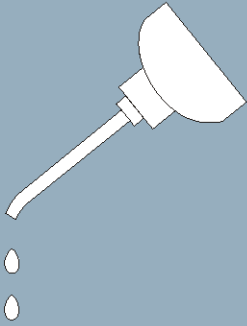
- Publishing System: TPAS2
- Access date: 09/07/2023
- Document ECNs: NOT latest



Installation and Service

COSHR111, COSHR112

COLFR111, COLFR112



**Read the
separate
safety
manual
before
installing,
operating,
or servicing**

Table of Contents

MPICOSHRAE/23333A

Page	Description	Document
1	Limited Standard Warranty	BMP720097/2019036
2	How to Get the Necessary Repair Components	BIUUUD19/20081231
3	Trademarks	BNUUUU02/2023296A
5	1. Safety Information	
6	Safety—Shuttle	BIUUUS27VS/20051111
11	Proximity Safeguarding for Automatic Shuttle Conveyors	BISUUU01/20171205
15	Use the Red Safety Supports for Maintenance — CA_, CG_, COEL_, COLF_, COSH_	BNSUUH01/2021344,
17	Safety Pin	BPSCUK01/2021344A
18	Understanding the Tag Guidelines	BIUUUI02VS/20120126
21	Safety Placard Use and Placement, All Elevating Conveyors	BMP070024/2007215V
23	Safety Placard Use and Placement ISO, All Elevating Conveyors	BMP070025/2007215V
25	2. Installation	
26	Attention Installers! Dryer Shuttle Rail Installation	B2T2007003/2019193A
27	Shuttle & Rail Installation COSHR111/112, COLFR111/112	MIQCOSHRAE/2018306A
39	Installation of the Laser Positioner for Traversing Shuttles	BIVSVI01/20151216
49	3. Service and Maintenance	
50	Shuttle Preventive Maintenance	BIVUUM01aa/20070306
55	Torque Requirements for Fasteners	BIUUUM04/20180109
63	Parts Identification	MGQCOSHRAE/2007103A
76	Parts List	MLQCOSHRAE/2007103B
83	4. Dimensional Drawings	
85	Dimensional Drawing - COSHR111	BDCOSHR1AE/2023333D
86	Dimensional Drawing - COSHR111 Horizontal	BDCOSHR1AB/2023333D
87	Dimensional Drawing - COSHR112	BDCOSHR2AE/2023333D
88	Dimensional Drawing - COSHR112 Horizontal	BDCOSHR2AB/2023333D
89	Dimensional Drawing - COLFR111	BDCOLFR1AE/2023333D
90	Dimensional Drawing - COLF111 Horizontal	BDCOLFR1AB/2023333D
91	Dimensional Drawing - COLFR112	BDCOLFR2AE/2023333D
92	Dimensional Drawing - COLFR122 Horizontal	BDCOLFR2AB/2023333D
93	Dimensional Drawing - CG4008FS	BDCG40FSAE/2009182D
95	Dimensional Drawing - CG4010FS	BDCG4010FSAE/2012444D
97	Dimensional Drawing - CG4010MS	BDCG4010MSAE/2015492D
99	Dimensional Drawing - CG4016GS	BDCG4016GSAE/2016494D
101	Dimensional Drawing - Minimum Clearance Cart Shuttle Rail	BDCTRAILAE/2020302D
103	Dimensional Drawing - Cart Rail Installation	BDCTRAILAB/2020302D

PELLERIN MILNOR CORPORATION LIMITED STANDARD WARRANTY

We warrant to the original purchaser that MILNOR machines including electronic hardware/software (hereafter referred to as "equipment"), will be free from defects in material and workmanship for a period of one year from the date of shipment (unless the time period is specifically extended for certain parts pursuant to a specific MILNOR published extended warranty) from our factory with no operating hour limitation. This warranty is contingent upon the equipment being installed, operated and serviced as specified in the operating manual supplied with the equipment, and operated under normal conditions by competent operators.

Providing we receive written notification of a warranted defect within 30 days of its discovery, we will—at our option—repair or replace the defective part or parts, EX Factory (labor and freight specifically NOT included). We retain the right to require inspection of the parts claimed defective in our factory prior to repairing or replacing same. We will not be responsible, or in any way liable, for unauthorized repairs or service to our equipment, and this warranty shall be void if the equipment is tampered with, modified, or abused, used for purposes not intended in the design and construction of the machine, or is repaired or altered in any way without MILNOR's written consent.

Parts damaged by exposure to weather, to aggressive water, or to chemical attack are not covered by this warranty. For parts which require routine replacement due to normal wear—such as gaskets, contact points, brake and clutch linings, belts, hoses, and similar parts—the warranty time period is 90 days.

We reserve the right to make changes in the design and/or construction of our equipment (including purchased components) without obligation to change any equipment previously supplied.

ANY SALE OR FURNISHING OF ANY EQUIPMENT BY MILNOR IS MADE ONLY UPON THE EXPRESS UNDERSTANDING THAT MILNOR MAKES NO EXPRESSED OR IMPLIED WARRANTIES OF MERCHANTABILITY OR FITNESS FOR ANY PARTICULAR USE OR PURPOSE OR ANY OTHER WARRANTY IMPLIED BY LAW INCLUDING BUT NOT LIMITED TO REDHIBITION. MILNOR WILL NOT BE RESPONSIBLE FOR ANY COSTS OR DAMAGES ACTUALLY INCURRED OR REQUIRED AS A RESULT OF: THE FAILURE OF ANY OTHER PERSON OR ENTITY TO PERFORM ITS RESPONSIBILITIES, FIRE OR OTHER HAZARD, ACCIDENT, IMPROPER STORAGE, MIS-USE, NEGLIGENCE, POWER OR ENVIRONMENTAL CONTROL MALFUNCTIONS, DAMAGE FROM LIQUIDS, OR ANY OTHER CAUSE BEYOND THE NORMAL RANGE OF USE. REGARDLESS OF HOW CAUSED, IN NO EVENT SHALL MILNOR BE LIABLE FOR SPECIAL, INDIRECT, PUNITIVE, LIQUIDATED, OR CONSEQUENTIAL COSTS OR DAMAGES, OR ANY COSTS OR DAMAGES WHATSOEVER WHICH EXCEED THE PRICE PAID TO MILNOR FOR THE EQUIPMENT IT SELLS OR FURNISHES.

THE PROVISIONS ON THIS PAGE REPRESENT THE ONLY WARRANTY FROM MILNOR AND NO OTHER WARRANTY OR CONDITIONS, STATUTORY OR OTHERWISE, SHALL BE IMPLIED.

WE NEITHER ASSUME, NOR AUTHORIZE ANY EMPLOYEE OR OTHER PERSON TO ASSUME FOR US, ANY OTHER RESPONSIBILITY AND/OR LIABILITY IN CONNECTION WITH THE SALE OR FURNISHING OF OUR EQUIPMENT TO ANY BUYER.

BMP720097/19036

How to Get the Necessary Repair Components



This document uses Simplified Technical English.
Learn more at <http://www.asd-ste100.org>.

You can get components to repair your machine from the approved supplier where you got this machine. Your supplier will usually have the necessary components in stock. You can also get components from the Milnor® factory.

Tell the supplier the machine model and serial number and this data for each necessary component:

- The component number from this manual
- The component name if known
- The necessary quantity
- The necessary transportation requirements
- If the component is an electrical component, give the schematic number if known.
- If the component is a motor or an electrical control, give the nameplate data from the used component.

To write to the Milnor factory:

Pellerin Milnor Corporation
Post Office Box 400
Kenner, LA 70063-0400
UNITED STATES

Telephone: 504-467-2787
Fax: 504-469-9777
Email: parts@milnor.com

— End of BIUUUD19 —

Trademarks

These words are trademarks of Pellerin Milnor® Corporation and other entities:

Table 1. Trademarks

AutoSpot™	GreenFlex™	MilMetrix®	PulseFlow®
CBW®	GearTrace™	MilTouch™	RAM Command™
Drynet™	GreenTurn™	MilTouch-EX™	RecircONE®
E-P Express®	Hydro-cushion™	MilRAIL®	RinSave®
E-P OneTouch®	Mentor®	Miltrac™	SmoothCoil™
E-P Plus®	Mildata®	MilVision™	Staph Guard®
Gear Guardian®	Milnor®	PBW™	

End of document: BNUUUU02

Safety Information

1

Safety—Shuttle

1. General Safety Requirements—Vital Information for Management Personnel [Document BIUUUS04]

Incorrect installation, neglected preventive maintenance, abuse, and/or improper repairs, or changes to the machine can cause unsafe operation and personal injuries, such as multiple fractures, amputations, or death. The owner or his selected representative (owner/user) is responsible for understanding and ensuring the proper operation and maintenance of the machine. The owner/user must familiarize himself with the contents of all machine instruction manuals. The owner/user should direct any questions about these instructions to a Milnor® dealer or the Milnor® Service department.

Most regulatory authorities (including OSHA in the USA and CE in Europe) hold the owner/user ultimately responsible for maintaining a safe working environment. Therefore, the owner/user must do or ensure the following:

- recognize all foreseeable safety hazards within his facility and take actions to protect his personnel, equipment, and facility;
- work equipment is suitable, properly adapted, can be used without risks to health or safety, and is adequately maintained;
- where specific hazards are likely to be involved, access to the equipment is restricted to those employees given the task of using it;
- only specifically designated workers carry out repairs, modifications, maintenance, or servicing;
- information, instruction, and training is provided;
- workers and/or their representatives are consulted.

Work equipment must comply with the requirements listed below. The owner/user must verify that installation and maintenance of equipment is performed in such a way as to support these requirements:

- control devices must be visible, identifiable, and marked; be located outside dangerous zones; and not give rise to a hazard due to unintentional operation;
- control systems must be safe and breakdown/damage must not result in danger;
- work equipment is to be stabilized;
- protection against rupture or disintegration of work equipment;
- guarding, to prevent access to danger zones or to stop movements of dangerous parts before the danger zones are reached. Guards to be robust; not give rise to any additional hazards; not be easily removed or rendered inoperative; situated at a sufficient distance from the danger zone; not restrict view of operating cycle; allow fitting, replacing, or maintenance by restricting access to relevant area and without removal of guard/protection device;
- suitable lighting for working and maintenance areas;
- maintenance to be possible when work equipment is shut down. If not possible, then protection measures to be carried out outside danger zones;
- work equipment must be appropriate for preventing the risk of fire or overheating; discharges of gas, dust, liquid, vapor, other substances; explosion of the equipment or substances in it.

- 1.1. **Laundry Facility**—Provide a supporting floor that is strong and rigid enough to support—with a reasonable safety factor and without undue or objectionable deflection—the weight of the fully loaded machine and the forces transmitted by it during operation. Provide sufficient clearance for machine movement. Provide any safety guards, fences, restraints, devices, and verbal and/or posted restrictions necessary to prevent personnel, machines, or other moving machinery from accessing the machine or its path. Provide adequate ventilation to carry away heat and vapors. Ensure service connections to installed machines meet local and national safety standards, especially regarding the electrical disconnect (see the National Electric Code). Prominently post safety information, including signs showing the source of electrical disconnect.



WARNING [1]: Collision, Crushing and Pinch Hazards—Serious bodily injury or death can result to personnel in proximity to machinery/systems that traverse, elevate, extend, pivot, and/or tilt. The following mandatory minimum safety requirements must be installed with the machinery system: • Safety fence inclosing machine movement areas, • Lockable electrical interlocks on all gates, properly interfaced as shown on machine schematics, to disable machine movement when any gate is opened, • Signs to alert personnel to these hazards, placed prominently around the fenced area. Local codes may require additional precautions.

- 1.2. **Personnel**—Inform personnel about hazard avoidance and the importance of care and common sense. Provide personnel with the safety and operating instructions that apply to them. Verify that personnel use proper safety and operating procedures. Verify that personnel understand and abide by the warnings on the machine and precautions in the instruction manuals.
- 1.3. **Safety Devices**—Ensure that no one eliminates or disables any safety device on the machine or in the facility. Do not allow machine to be used with any missing guard, cover, panel or door. Service any failing or malfunctioning device before operating the machine.
- 1.4. **Hazard Information**—Important information on hazards is provided on the machine safety placards, in the Safety Guide, and throughout the other machine manuals. **Placards must be kept clean so that the information is not obscured. They must be replaced immediately if lost or damaged. The Safety Guide and other machine manuals must be available at all times to the appropriate personnel.** See the machine service manual for safety placard part numbers. Contact the Milnor Parts department for replacement placards or manuals.
- 1.5. **Maintenance**—Ensure the machine is inspected and serviced in accordance with the norms of good practice and with the preventive maintenance schedule. Replace belts, pulleys, brake shoes/disks, clutch plates/tires, rollers, seals, alignment guides, etc. before they are severely worn. Immediately investigate any evidence of impending failure and make needed repairs (e.g., cylinder, shell, or frame cracks; drive components such as motors, gear boxes, bearings, etc., whining, grinding, smoking, or becoming abnormally hot; bending or cracking of cylinder, shell, frame, etc.; leaking seals, hoses, valves, etc.) Do not permit service or maintenance by unqualified personnel.

2. **Safety Alert Messages—Internal Electrical and Mechanical Hazards** [Document BIUUUS11]

The following are instructions about hazards inside the machine and in electrical enclosures.



WARNING [2]: Electrocution and Electrical Burn Hazards—Contact with electric power can kill or seriously injure you. Electric power is present inside the cabinetry unless the main machine power disconnect is off.

- Do not unlock or open electric box doors.

- Do not remove guards, covers, or panels.
- Do not reach into the machine housing or frame.
- Keep yourself and others off of machine.
- Know the location of the main machine disconnect and use it in an emergency to remove all electric power from the machine.



WARNING [3]: Entangle and Crush Hazards—Contact with moving components normally isolated by guards, covers, and panels, can entangle and crush your limbs. These components move automatically.

- Do not remove guards, covers, or panels.
- Do not reach into the machine housing or frame.
- Keep yourself and others off of machine.
- Know the location of all emergency stop switches, pull cords, and/or kick plates and use them in an emergency to stop machine motion.

3. Safety Alert Messages—External Mechanical Hazards [Document BIUUUS12]

The following are instructions about hazards around the front, sides, rear or top of the machine.



CAUTION [4]: Strike and Crush Hazards—A traveling machine such as a shuttle can strike, crush, or entrap you if you ride on it or enter its path. Traveling machines or their components can move automatically in any direction. Placing a system machine on line by energizing the machine control may immediately summon a shuttle or other traveling machine.

- Keep yourself and others off of machine.
- Keep yourself and others clear of movement areas and paths.
- Understand the consequences of placing a system machine on line.
- Know the location of all emergency stop switches, pull cords, and/or kick plates and use them in an emergency to stop machine motion.
- Know the location of the main machine disconnect and use it in an emergency to remove all electric power from the machine.



CAUTION [5]: Crush and Entrap Hazards—A traveling machine such as a shuttle can crush or entrap you if the bed or bucket descends while you are under it. The bed or bucket can descend with power off or on.

- Keep yourself and others clear of movement areas and paths.



WARNING [6]: Fall, Entangle, and Strike Hazards—Machine motion can cause you to fall or become entangled in or struck by nearby objects if you stand, walk, or ride on the machine. Shuttles and conveyor belts move automatically.

- Keep yourself and others off of machine.

4. Safety Alert Messages—Unsafe Conditions [Document BIUUUS14]

4.1. Damage and Malfunction Hazards

4.1.1. Hazards Resulting from Inoperative Safety Devices



WARNING 7: Multiple Hazards—Operating the machine with an inoperative safety device can kill or injure personnel, damage or destroy the machine, damage property, and/or void the warranty.

- Do not tamper with or disable any safety device or operate the machine with a malfunctioning safety device. Request authorized service.



WARNING 8: Electrocutation and Electrical Burn Hazards—Electric box doors—Operating the machine with any electric box door unlocked can expose high voltage conductors inside the box.

- Do not unlock or open electric box doors.



WARNING 9: Entangle and Crush Hazards—Guards, covers, and panels—Operating the machine with any guard, cover, or panel removed exposes moving components.

- Do not remove guards, covers, or panels.

4.1.2. Hazards Resulting from Damaged Mechanical Devices



WARNING 10: Multiple Hazards—Operating a damaged machine can kill or injure personnel, further damage or destroy the machine, damage property, and/or void the warranty.

- Do not operate a damaged or malfunctioning machine. Request authorized service.



WARNING 11: Crush Hazards—Chain and hoist—A broken chain or a malfunctioning hoist can permit the belt/bucket assembly to fall or descend.

- Do not operate the machine with any evidence of damage or malfunction.

4.2. Careless Use Hazards

4.2.1. Careless Operation Hazards—Vital Information for Operator Personnel (see also operator hazards throughout manual)



WARNING 12: Multiple Hazards—Careless operator actions can kill or injure personnel, damage or destroy the machine, damage property, and/or void the warranty.

- Do not tamper with or disable any safety device or operate the machine with a malfunctioning safety device. Request authorized service.
- Do not operate a damaged or malfunctioning machine. Request authorized service.
- Do not attempt unauthorized servicing, repairs, or modification.
- Do not use the machine in any manner contrary to the factory instructions.
- Use the machine only for its customary and intended purpose.
- Understand the consequences of operating manually.



CAUTION 13: Goods Damage and Wasted Resources—Entering incorrect cake data causes improper processing, routing, and accounting of batches.

- Understand the consequences of entering cake data.



WARNING 14: Strike and Crush Hazards—Carelessly moving the machine with manual controls can cause it to strike, crush, entrap, or entangle personnel. You have total control of machine movement immediately after setting the Manual/Automatic switch to manual.

- Keep yourself and others clear of movement areas and paths.
- Understand the consequences of operating manually.

4.2.2. Careless Servicing Hazards—Vital Information for Service Personnel (see also service hazards throughout manuals)



WARNING 15: Electrocutation and Electrical Burn Hazards—Contact with electric power can kill or seriously injure you. Electric power is present inside the cabinetry unless the main machine power disconnect is off.

- Do not service the machine unless qualified and authorized. You must clearly understand the hazards and how to avoid them.
- Abide by the current OSHA lockout/tagout standard when lockout/tagout is called for in the service instructions. Outside the USA, abide by the OSHA standard in the absence of any other overriding standard.



WARNING 16: Entangle and Crush Hazards—Contact with moving components normally isolated by guards, covers, and panels, can entangle and crush your limbs. These components move automatically.

- Do not service the machine unless qualified and authorized. You must clearly understand the hazards and how to avoid them.
- Abide by the current OSHA lockout/tagout standard when lockout/tagout is called for in the service instructions. Outside the USA, abide by the OSHA standard in the absence of any other overriding standard.



WARNING 17: Crush and Entrap Hazards—A traveling machine such as a shuttle can crush or entrap you if the bed or bucket descends while you are under it. The bed or bucket can descend with power off or on.

- Secure both red safety pins in accordance with the instructions furnished, then lock out and tag out power at the main machine disconnect before working under bed or bucket.



WARNING 18: Strike and Crush Hazards—A traveling machine such as a shuttle can strike, crush, or entrap you if you ride on it or enter its path. Traveling machines or their components can move automatically in any direction. Placing a system machine on line by energizing the machine control may immediately summon a shuttle or other traveling machine.

- Lock out and tag out power to the traveling machine at the main machine disconnect if you must work in the path of the traveling machine.

— End of BIUUUS27 —

Proximity Safeguarding for Automatic Shuttle Conveyors

Proximity safeguarding—a means of preventing personnel from entering the path of a machine, such as an industrial robot, that moves within a large area.

1. Applicability

This document—

applies to Milnor® automated laundering systems with shuttle conveyors that move without operator intervention (automatic operation),

does not apply to shuttles that require operator input continually, such as directing all shuttle movements (manual operation).

2. References for Proximity Safeguarding

ANSI Z8.1-2016 “American National Standard for Commercial Laundry and Drycleaning Equipment and Operations - Safety Requirements”

OSHA Standard 29 CFR § 1910.212 “General Requirements for All Machines”

OSHA Directive STD 01-12-002 - Pub 8-1.3 “Guidelines for Robotic Safety”

ANSI/RIA R15.06-2012 “American National Standard for Industrial Robots and Robot Systems- Safety Requirements”

ANSI/ASME B15.1-2000 “Safety Standard for Mechanical Power Transmission Apparatus”

OSHA Publication 3067 “Concepts and Techniques of Machine Safeguarding”

ISO 10472-1 “Safety Requirements for Industrial Laundry Machinery”

3. Hazards To Personnel in Proximity to Shuttle Conveyors

Milnor automated laundering systems use automatic shuttle conveyors to transport goods among the processing machines in the system. Depending on model, an automatic shuttle conveyor may move in any of the following ways, in addition to running its conveyor belt(s):

- It may travel along (traverse) a line of machines (typically dryers).
- Its conveyor bed(s) may ascend and descend (elevate) within the machine frame.
- Its conveyor bed(s) may extend and retract within the machine frame.
- The conveyor bed and frame may pivot.
- Wet goods shuttles have a bucket that elevates and tilts.

These motions pose strike, crush, sever, and entrapment hazards to personnel in proximity to the shuttle. **For the safety of personnel, owner/users must provide proximity safeguarding that protects personnel from the moving shuttle.**

A common method of proximity safeguarding is safety fencing with interlocked gates that disable the shuttle when a gate is opened. When a shuttle is disabled, this will eventually cause other machines in the system to hold (wait for action from another machine), but it will not necessarily cause them to immediately stop moving. In the case of a tunnel system, the press or centrifugal extractor can pose additional hazards to personnel in proximity to the equipment. **Hence, the safeguards must also disable any presses or extractors.** Tunnels and dryers do not pose a significant hazard to personnel merely because they are in proximity to the equipment, and need not be automatically disabled.



WARNING 1: Multiple Hazards—Proximity safeguarding provides only partial protection and only against injury resulting from entering the shuttle path. It is not a substitute for proper

lockout/tagout procedures and good safety practices.

- Always lockout/tagout any individual machine (or follow the published maintenance procedures) when performing maintenance or clearing a fault on that machine.
- Ensure that all personnel understand the safeguards and do not attempt to defeat them.
- Inspect safeguards weekly to ensure that they are not mechanically or electrically circumvented.

4. How Milnor Accommodates Proximity Safeguarding

Milnor provides connection points on shuttles, presses and centrifugal extractors for interfacing with devices such as gate interlock switches. These connection points are tagged for easy identification. When Milnor provides equipment layout drawings for an automated laundering system, it indicates on the drawing, the perimeter of the shuttle movement area that must be guarded. The following hazard statement is displayed on connection point tags as well as equipment layout drawings prepared by Milnor:



WARNING 2: Strike, Crush, Sever, and Entrapment Hazards—Serious bodily injury or death can result to personnel in proximity to machinery/systems that traverse, elevate, extend, pivot, and/or tilt. The following mandatory minimum safety requirements must be installed with the machinery system (local codes may require additional precautions):

- Safety fence enclosing machine movement areas,
- Lockable electrical interlocks on all gates, properly interfaced as shown on machine schematics, to disable machine movement when any gate is opened,
- Signs to alert personnel to these hazards, placed prominently around the fenced area.

Although the objectives of proximity safeguarding are the same anywhere, design requirements vary with local codes (which occasionally change) and with the plant layout. For this reason, Milnor does not provide detailed designs or materials for proximity safeguarding. If the necessary expertise does not exist within the owner/user's organization, consult appropriate sources such as local engineers or architects specializing in industrial facility design.

5. Examples of Safety Fencing With Interlocked Gates

Fencing with interlocked gates like that depicted in [Figure 1](#) and [Figure 2](#), may be used to meet the proximity safeguarding requirement. Should the owner/user choose this method, the following information may be useful. However, **this information may not satisfy current or local code requirements. The owner/user must determine its suitability for his particular facility.**

Figure 1: Example Fence Layout for Automated Laundering System Where One Tunnel Serves a Bank of Dryers

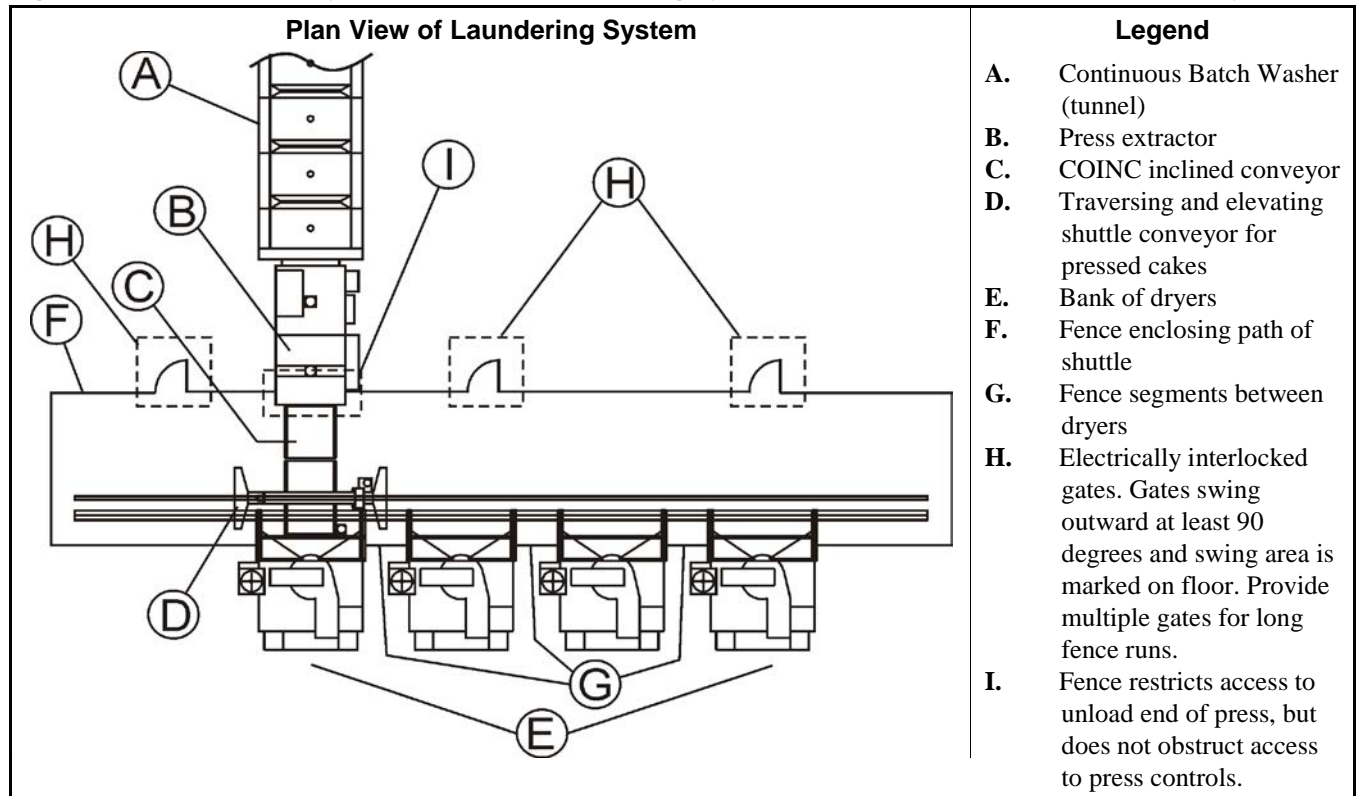
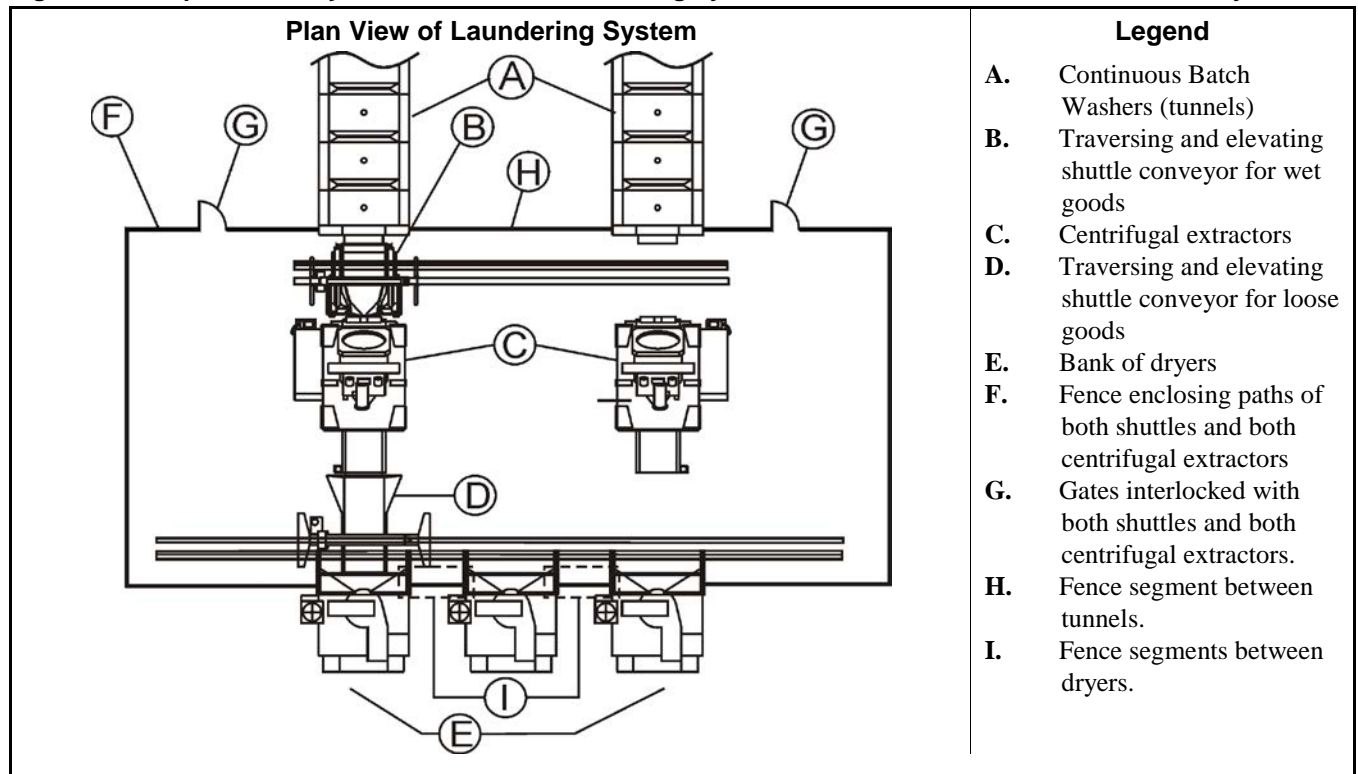


Figure 2: Example Fence Layout for Automated Laundering System Where Two Tunnels Serve a Bank of Dryers



- 5.1. Fence Dimensions**—The fence must discourage climbing over and prevent crawling under.
- 5.2. Fence Materials and Setback**—The fence must be constructed of materials and located so as to prevent personnel from reaching through gaps in the fence and contacting the enclosed machinery.
- 5.3. Gates**—Personnel gates must be held firmly closed but permit personnel to easily pass through when necessary. Gates must be equipped with a positive latching arrangement to prevent accidental opening. Adequate floor space must be provided to allow the gate to swing at least 90 degrees when fully open. Gates must open outward; that is, away from the fenced perimeter. The floor must be permanently marked to show the gate’s swing area, to discourage obstructing its movement.
- 5.4. Control Circuitry**—All gates must be electrically interlocked with any shuttle conveyors within the fenced area and with any presses or centrifugal extractors that the fence either encloses or intersects. Opening any gate must have the following effects:
1. Shuttle(s), press(es), and/or centrifugal extractor(s) stop moving immediately.
 2. An audible alarm sounds.
 3. Shuttle(s), press(es), and/or centrifugal extractor(s) cannot be restarted merely by closing the gate(s), but must be restarted at the machine control panel once the gate(s) are closed.
- Milnor shuttles, presses and centrifugal extractors provide such functionality when properly interfaced with gate interlock switches.
- 5.5. System Emergency Stop Switches**—The laundry must establish rules and procedures that prohibit personnel from remaining within the fenced area with machine(s) enabled, except in accordance with published maintenance procedures. System emergency stop switches (panic buttons) should be provided inside and outside the fenced perimeter. Emergency stop switches should be located so that personnel anywhere inside the fenced perimeter are only a short distance from a switch, and they should be clearly marked as to their locations and function. Connect switches in series with the gate interlocks so that pressing an emergency stop switch performs the same control function as opening a gate.
- 5.6. Isolating Individual Machine Controls**—The interlock circuitry for each machine must be electrically isolated from that of the other machines. Hence, each gate interlock switch must provide as many pairs of dry contacts as there are machines to interface to. A pair of switch contacts must never be shared by two or more machines.
- 5.7. Recommended Signage**—Safety placards should be posted along the fence and at each gate, alerting personnel to the hazards within. At minimum, the size of lettering and distance between placards should be such that anyone contemplating entering the fenced area will likely see and read the placard first. Wording should be provided in each native language spoken by laundry personnel.

— End of BISUII01 —

Use the Red Safety Supports for Maintenance — CA_, CG_, COEL_, COLF_, COSH_

BNSUUH01.C01 0000374279 A.7 A.4 8/18/21 8:51 AM Released

1. What Safety Supports are Provided and Why

BNSUUH01.C02 0000374278 A.7 8/19/21 9:52 AM Released

These machines are provided with two safety pins. After the bed is raised, the pins are inserted in holes in both sides of the frame. The safety pins provide protection against the unpowered descent of the bed during maintenance. A mechanical problem such as a broken chain can cause the bed to fall. Use the safety support(s) whenever the maintenance to be performed requires you to place any part of your body in or near the path of the vertically moving portion of the machine.



WARNING: **Incorrect use of the safety supports** — can cause the machine to descend and crush you.



- ▶ Never work near the path of the vertically moving portion of the machine unless the safety supports are deployed and power is removed from the machine.
- ▶ Do not use power to close a small gap between the machine and the safety supports. Use care not to lower the machine with the safety supports

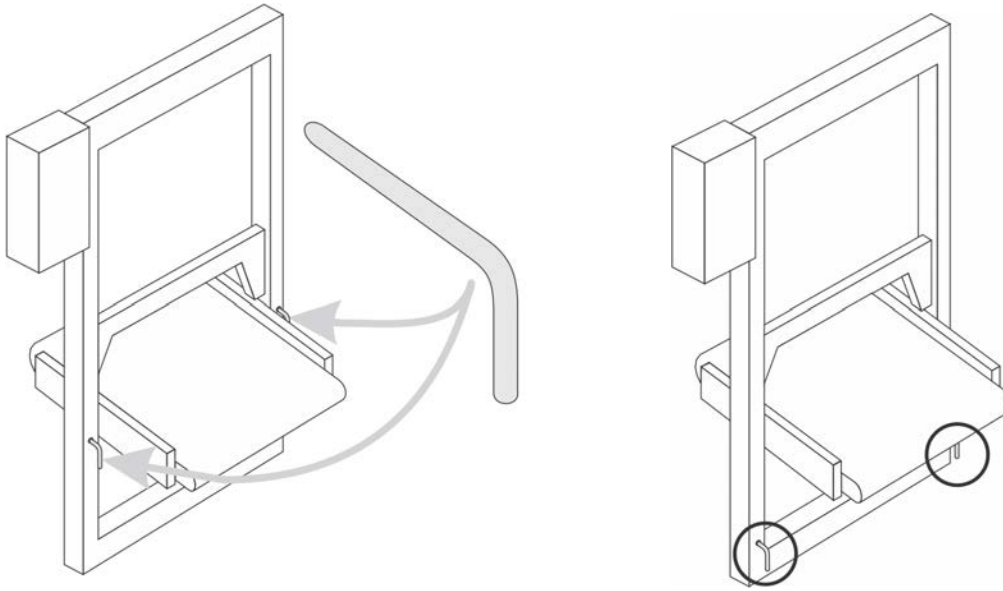
deployed.

- ▶ Where a pair of safety supports is provided, always use both supports.
- ▶ Maintain the safety support(s) in good condition.
- ▶ When not in use, stow the safety support(s) in the location(s) provided on the machine or in a convenient, designated location.

2. How to Deploy the Safety Pins

BNSUUH01.T01 0000374277 A.7 A.6 8/19/21 10:04 AM Released

1. Use the Manual mode to raise the bed or bucket carrier only as far as needed to insert the pins at one of the receptacle holes.
2. The illustrations below show the safety pins deployed (at left) and stowed (at right). Install the safety pins into the receptacle holes in the frame.



3. Remove electric power from the machine.

End of document: BNSUUH01

Safety Pin

All Elevating Shuttles and Pivoting Elevators.

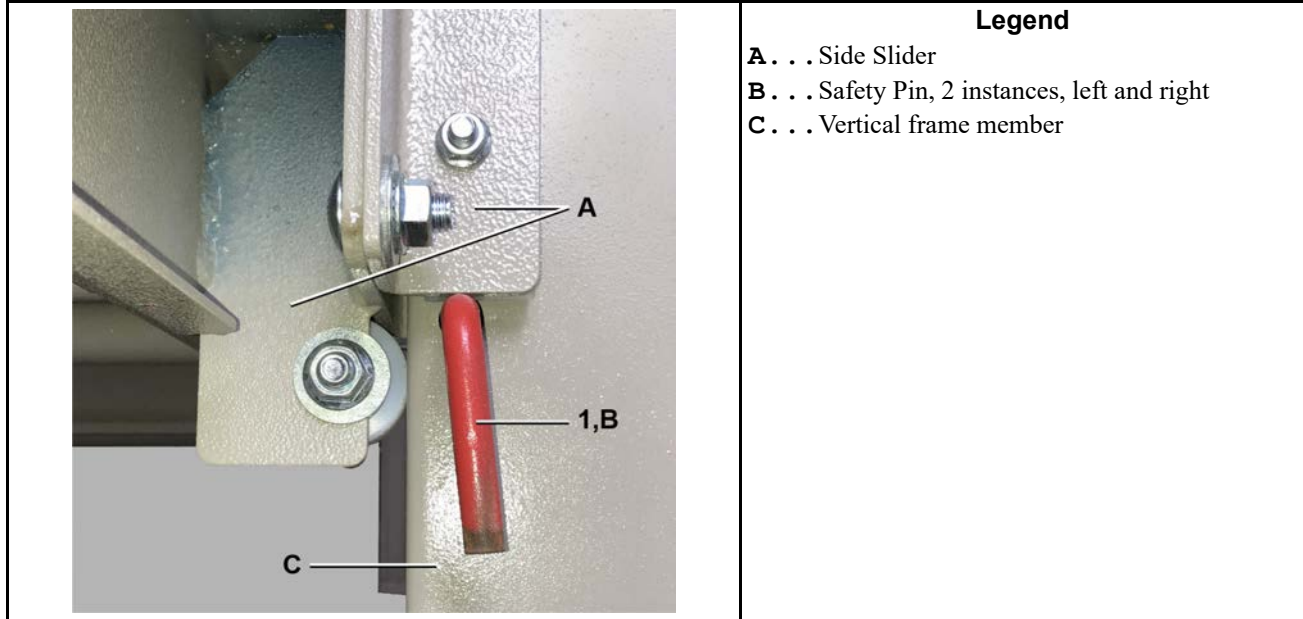


Table 1. Parts List—Safety Pin

Find the assembly for your machine and the letter shown in the "Item" column. The components for your machine will show this letter or the word "all" in the "Used In" column. The numbers shown in the "Item" column are those shown in the illustrations.				
Used In	Item	Part Number	Description/Nomenclature	Comments
Components				
all	1	04 21496	SAFETY PIN-COSHA	

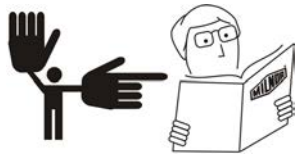
Understanding the Tag Guidelines for the Models Listed Below

COELD111	COELF111	COELF112	COELF113	COELF121	COELF122	COLFB111
COLFB112	COLFK111	COLFK112	COLFM111	COLFM112	COLFP111	COLFP112
COLFQ111	COLFQ112	COLFR111	COLFR112	COSAT111	COSAT112	COSAT121
COSHA111	COSHA112	COSHA113	COSHA114	COSHA121	COSHA122	COSHB111
COSHB112	COSHE122	COSHJ112	COSHJH12	COSHK111	COSHK112	COSHM111
COSHM112	COSHP111	COSHP112	COSHQ111	COSHQ112	COSHR111	COSHR112
COSTA112	COSTA113	COSTA114	COSTA121	COSTA122	COSTA123	COSTA124
COSTE112	COSTE113	COSTE114	COSTE122	COSTE123	COSTE124	COSTQ114
COSTR112						

Several installation guidelines and precautions are displayed symbolically, on tags placed at the appropriate locations on the machine. Some are tie-on and others are adhesive tags. Tie-on tags and white, adhesive tags may be removed after installation. Yellow adhesive tags must remain on the machine.

Most tags contain only symbols (no words). A few are worded. The explanations below, start with the tag part number (displayed on the tag). If a tag contains no words, the meaning of the tag is explained below. If the tag contains words, the explanation below simply repeats the wording.

Display or Action



Explanation

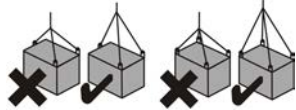
Read the manual before proceeding. This symbol appears on most tags. The machine ships with a complete set of manuals. The safety, installation, and electrical schematic manuals are particularly important to installers.



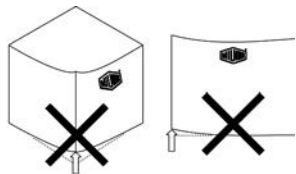
B2TAG88005: This carefully built product was tested and inspected to meet Milnor® performance and quality standards by



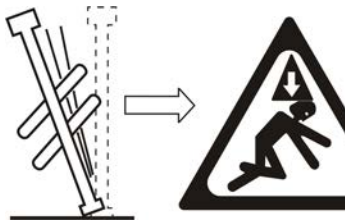
B2TAG94078: Do not forklift here; do not jack here; do not step here—whichever applies.



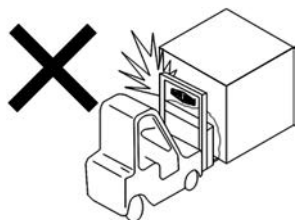
B2TAG94079: Rig for crane lifting (either 3-point or 4-point, depending on the number of lifting eyes provided) using a steep angle on the chains (closer to vertical than horizontal).



B2TAG94084: Do not lift from one corner of the machine, as this can cause the frame to rack, damaging it.



B2TAG94089: Do not attempt to balance the shuttle on the lower shipping brackets. Always suspend and lift the shuttle from the lifting eyes at the top of the machine.



B2TAG94118: Do not strike shipping container during forklifting. Fragile components inside.

Display or Action



Explanation

B2T2001028: Look for tags inside the machine. These tags may identify shipping restraints to be removed or components to be installed. Do not start the machine until these actions are completed.

B2T2002013: Do not start the machine until shipping restraints are removed. This tag will appear on the outside of the machine to alert you to the presence of internal shipping restraints. A tag will also appear on the restraint to help identify it. Most, but not all shipping restraints display the color red. Some shipping restraints are also safety stands. Do not discard these.



B2T2007003: Install the shuttle rail in accordance with this instruction and the installation manual.



B2T2010001: Mount festoon tow bar this way. (Used only on COSHM, COSHP, COSHQ & COSHR models.)

— End of BIUUUI02 —

Safety Placard Use and Placement

ALL ELEVATING CONVEYORS

BMP070024/2007215B
(Sheet 1 of 2)

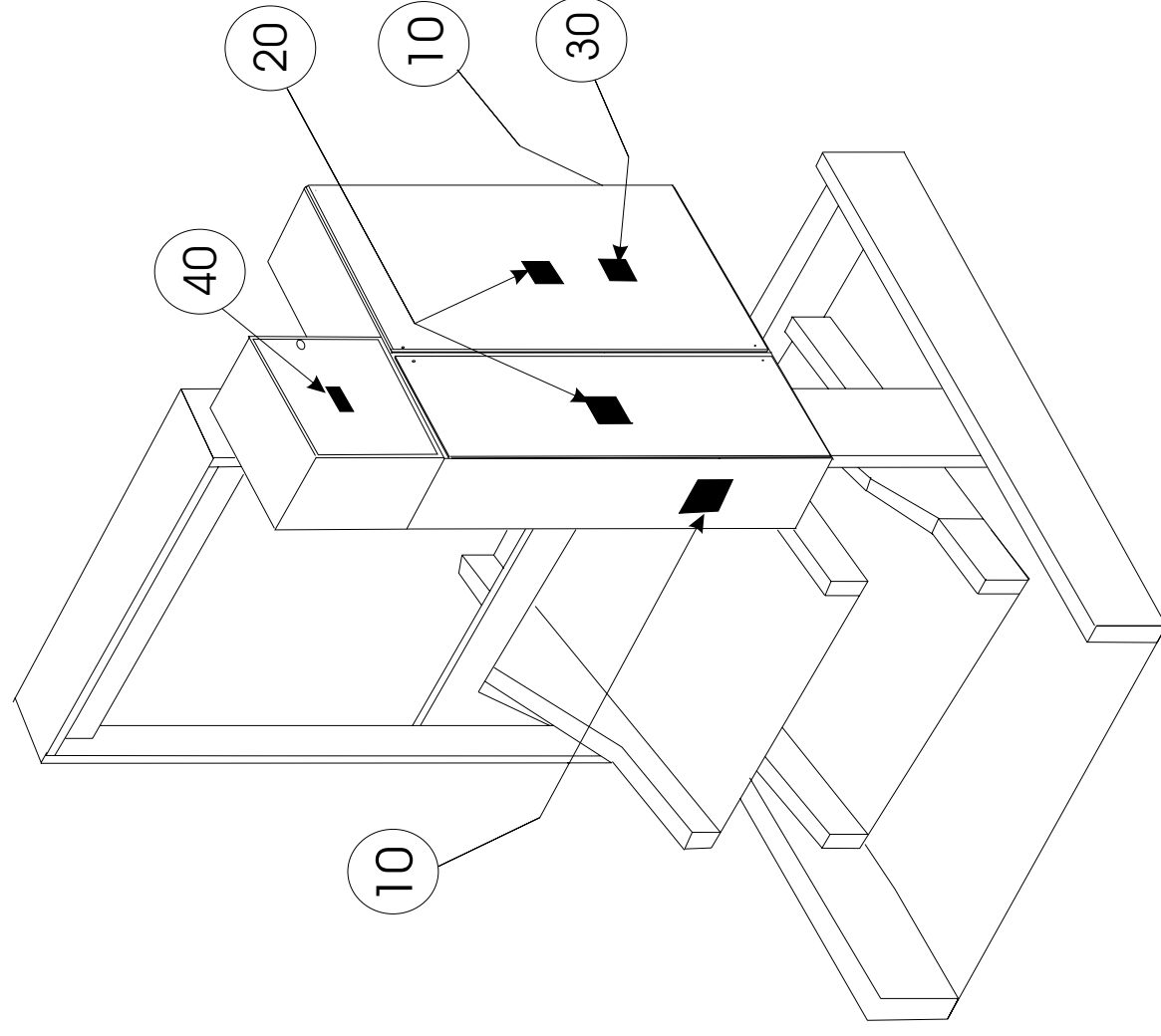


Pellerin Milnor Corporation
P. O. Box 400, Kenner, LA 70063-0400

Litho in U.S.A.

Notes:

1. Replace placard immediately, if removed or unreadable.
2. Approximate locations of placards are shown. Mounting holes are provided on machine. Use #8 self-tapping screws.





Pellerin Milnor Corporation
P. O. Box 400, Kenner, LA 70063-0400

Litho in U.S.A.

Parts List—Safety Placard Placement

Find the correct assembly first, then find the needed components. The item letters (A, B, C, etc.) assigned to assemblies are referred to in the "Used In" column to identify which components belong to an assembly. The item numbers (1, 2, 3, etc.) assigned to components relate the parts list to the illustration.

Used In	Item	Part Number	Description	Comments
-----ASSEMBLIES-----				
			none	
-----COMPONENTS-----				
all	10	01 10564A	NPLT: COSHA HAZARDS-TCATA	
all	20	01 10377A	NPLT: ELEC HAZARD LG-TCATA	
all	30	01 10699A	NPLT: SERV HZRD-PLYEST-TCATA	
all	40	01 10375B	NPLT: ELEC HAZARD SMALL-TCATA	



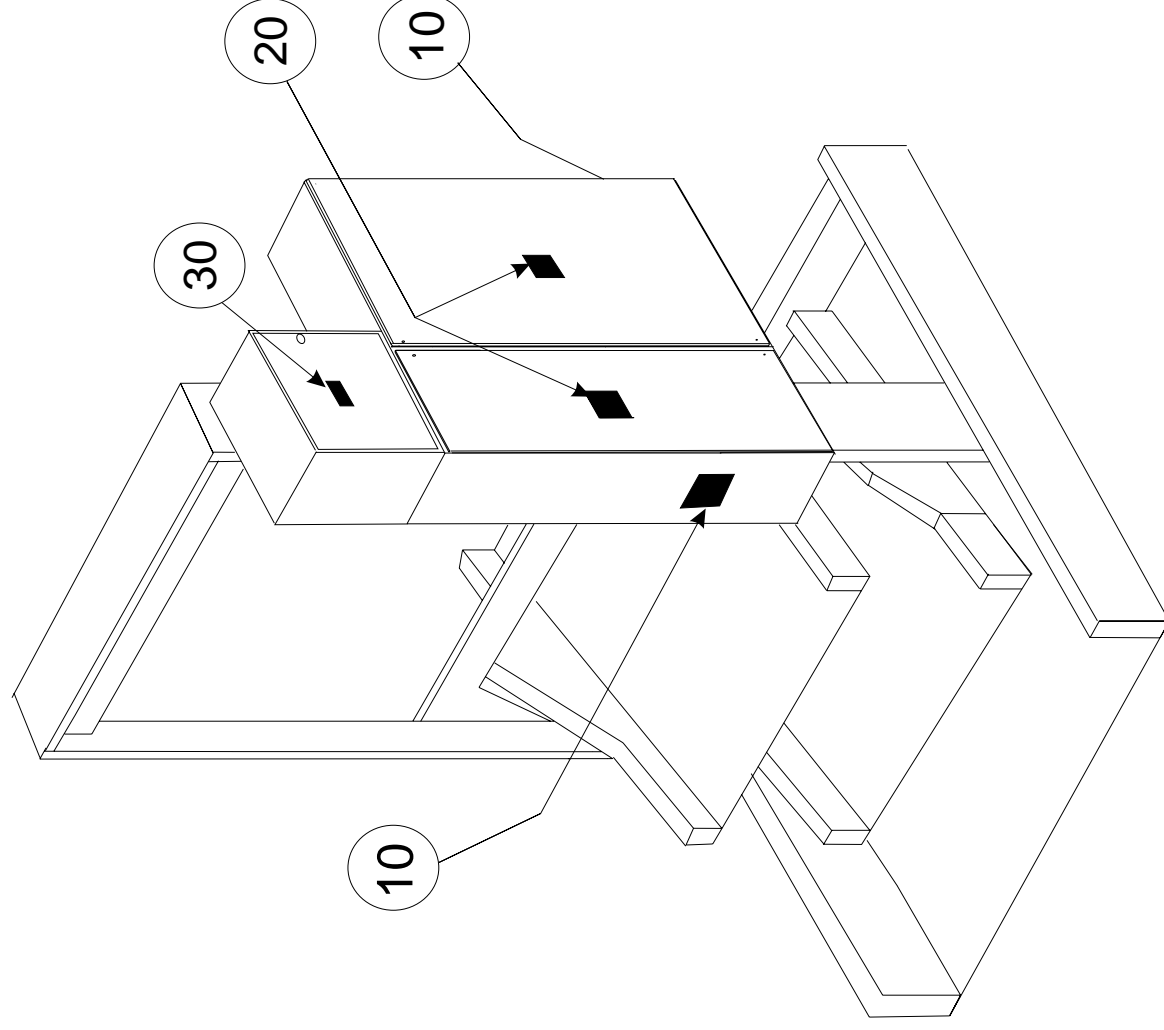
Pellerin Milnor Corporation
P. O. Box 400, Kenner, LA 70063-0400

Litho in U.S.A.

ISO Placards
shown on this page

Notes:

1. Replace placard immediately, if removed or unreadable.
2. Approximate locations of placards are shown. Mounting holes are provided on machine. Use #8 self-tapping screws.





Pellerin Milnor Corporation
P. O. Box 400, Kenner, LA 70063-0400

Litho in U.S.A.

Parts List—Safety Placard Placement

Find the correct assembly first, then find the needed components. The item letters (A, B, C, etc.) assigned to assemblies are referred to in the "Used In" column to identify which components belong to an assembly. The item numbers (1, 2, 3, etc.) assigned to components relate the parts list to the illustration.

Used In	Item	Part Number	Description	Comments
-----ASSEMBLIES-----				
none				
-----COMPONENTS-----				
all	10	01 10564X	WARNINGS:SHUTTLE ISO	
all	20	01 10377	NPLT:"WARNING" 4X4	
all	30	01 10375	NPLT:"WARNING" 2X2	

Installation

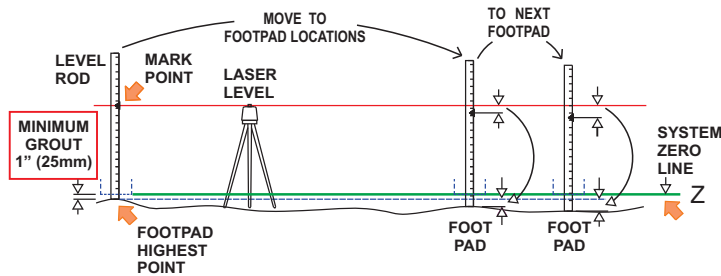
2

ATTENTION INSTALLERS!



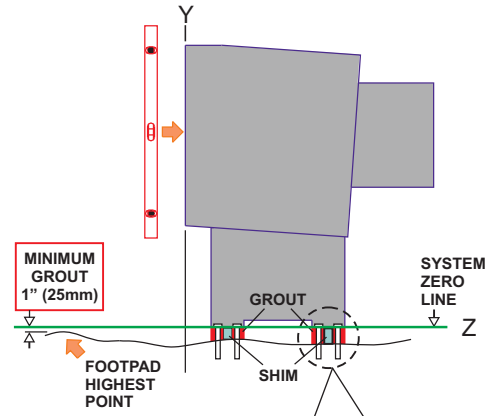
FLOOR IS UNEVEN

- Establish System Zero Line or Z.
- Find highest point in factory floor where footpads will be located.
- System Zero Line or Z is 1" above highest point.



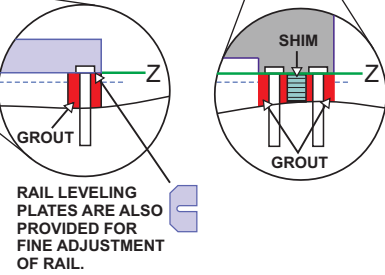
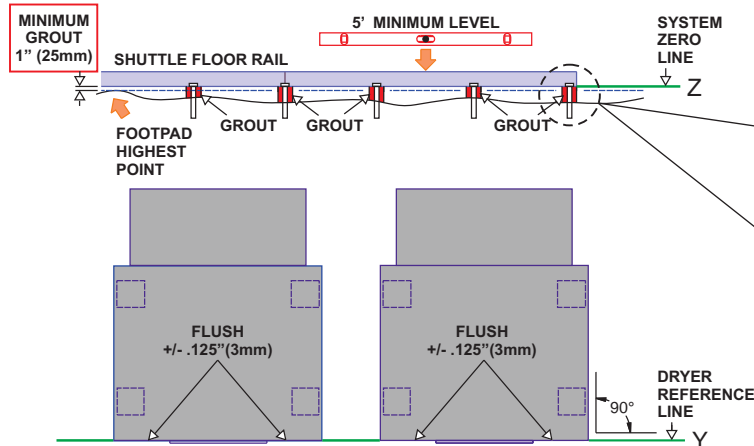
DRYER FEET MUST BE GROUTED

- Shim & level to System Zero Line or Z.
- Grout & anchor all brackets.

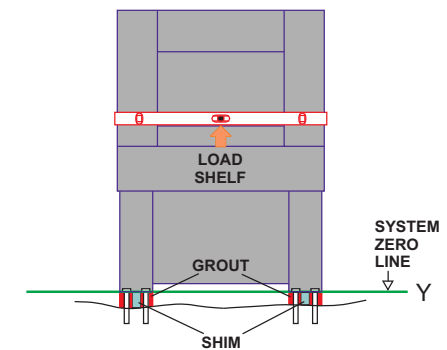
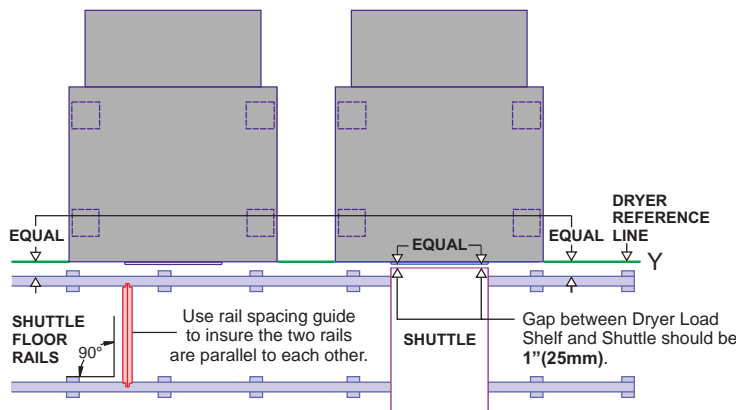


SHUTTLE RAIL BRACKETS MUST BE GROUTED TO Z

- Shim & level to System Zero Line or Z.
- Grout & anchor all brackets.



DRYER FACES MUST BE FLUSH



DRYER MUST BE LEVEL

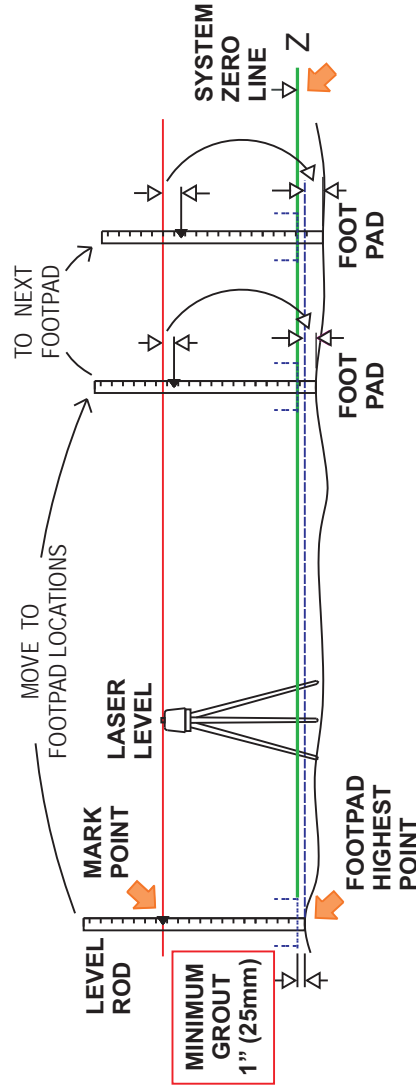
SHUTTLE RAILS MUST BE PERFECTLY PARALLEL TO DRYER FACES

- Floor rails must be parallel, level, and square along entire length of rail.



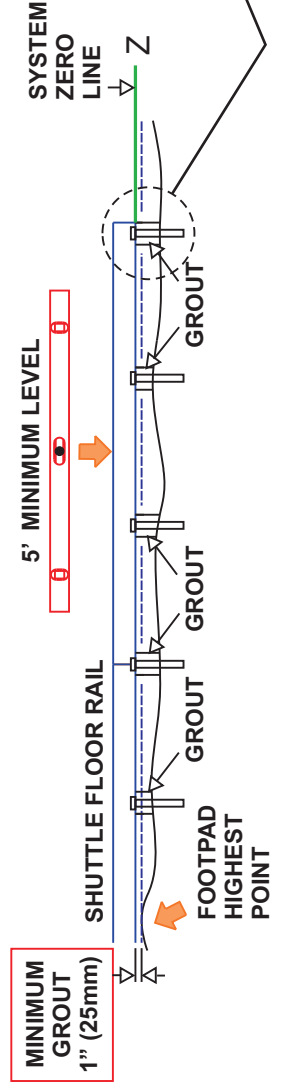
FLOOR IS UNEVEN

- Establish System Zero Line or Z.
- Find highest point in factory floor where footpads will be located.
- System Zero Line or Z is 1" above highest point.



SHUTTLE RAIL BRACKETS MUST BE GROUTED TO Z

- Shim & level to System Zero Line or Z.
- Grout & anchor all brackets.



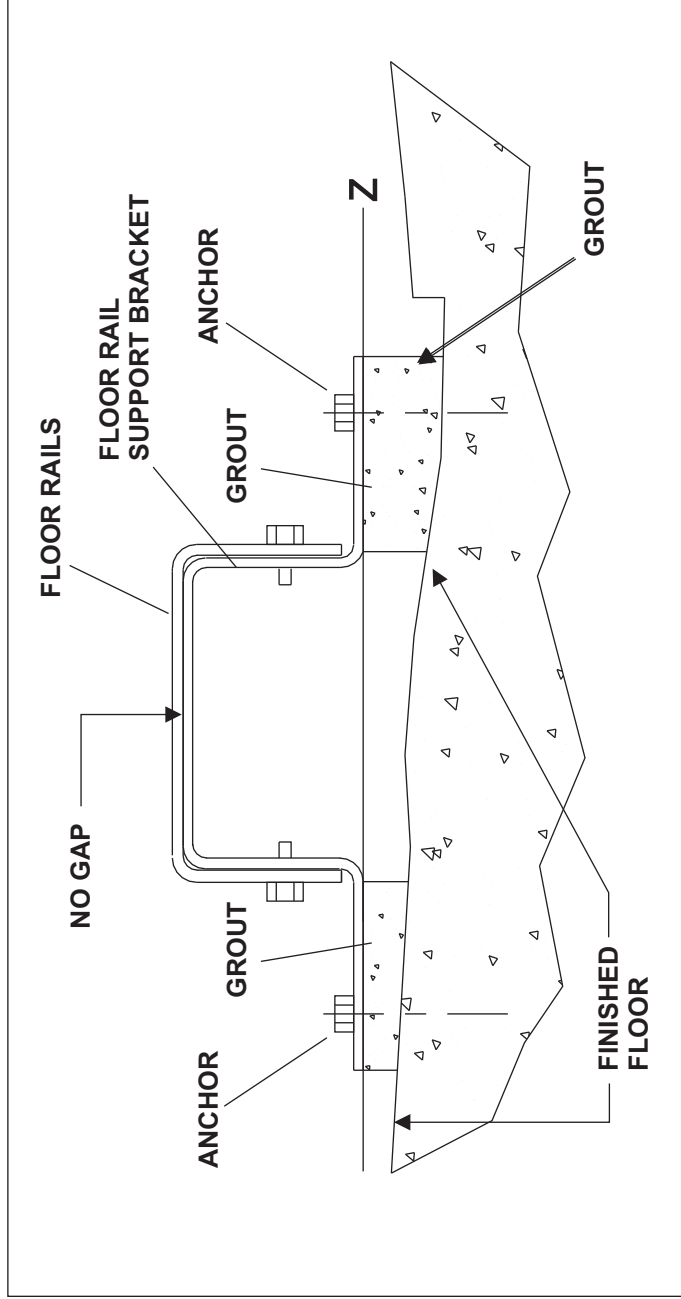
RAIL LEVELING PLATES ARE ALSO PROVIDED FOR FINE ADJUSTMENT OF RAIL.

Rail Installation:
 Floor Rails



Rail Installation:

Floor Rails

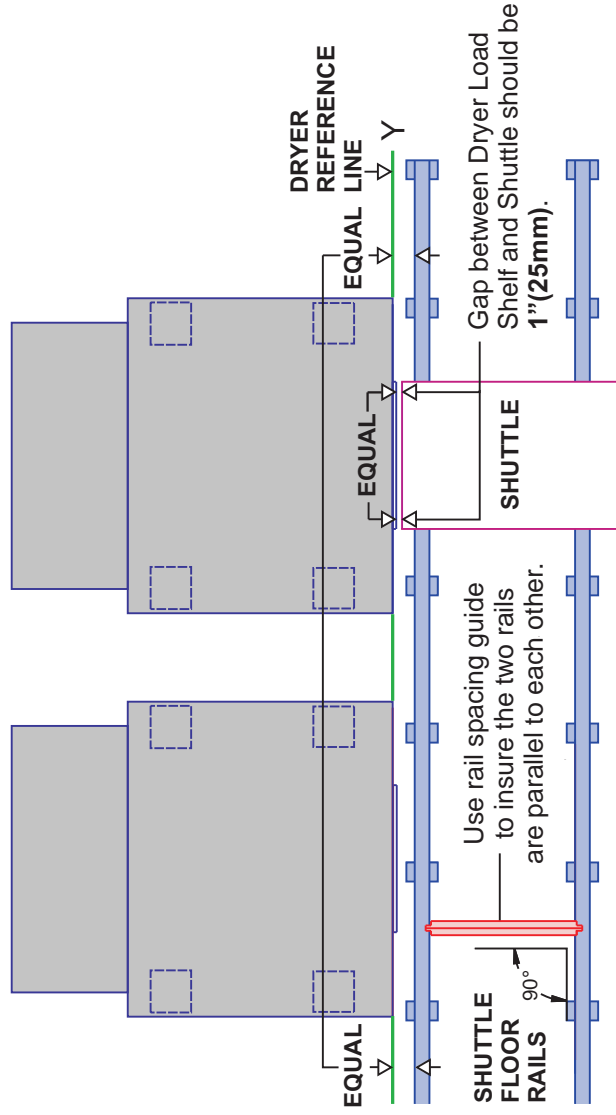


- Shim & level to System Zero Line or Z.
All floor rails must be level and square along the entire length of rail.
Locate each rail support bracket and level uneven finished floor with grout, with a minimum of 1"(25MM) of grout, under and around all floor rail support brackets. Use rail leveling plates to fill the gap and level the rail.
CAUTION: Make sure there is no gap between floor rails and floor rail support brackets.
- Grout & anchor all brackets.
Anchor the rail at all floor rail support brackets, both sides.
See (PAGE 4 of 11) and Dimensional Drawing for proper placement of floor rails.



Rail Installation:

Floor Rails



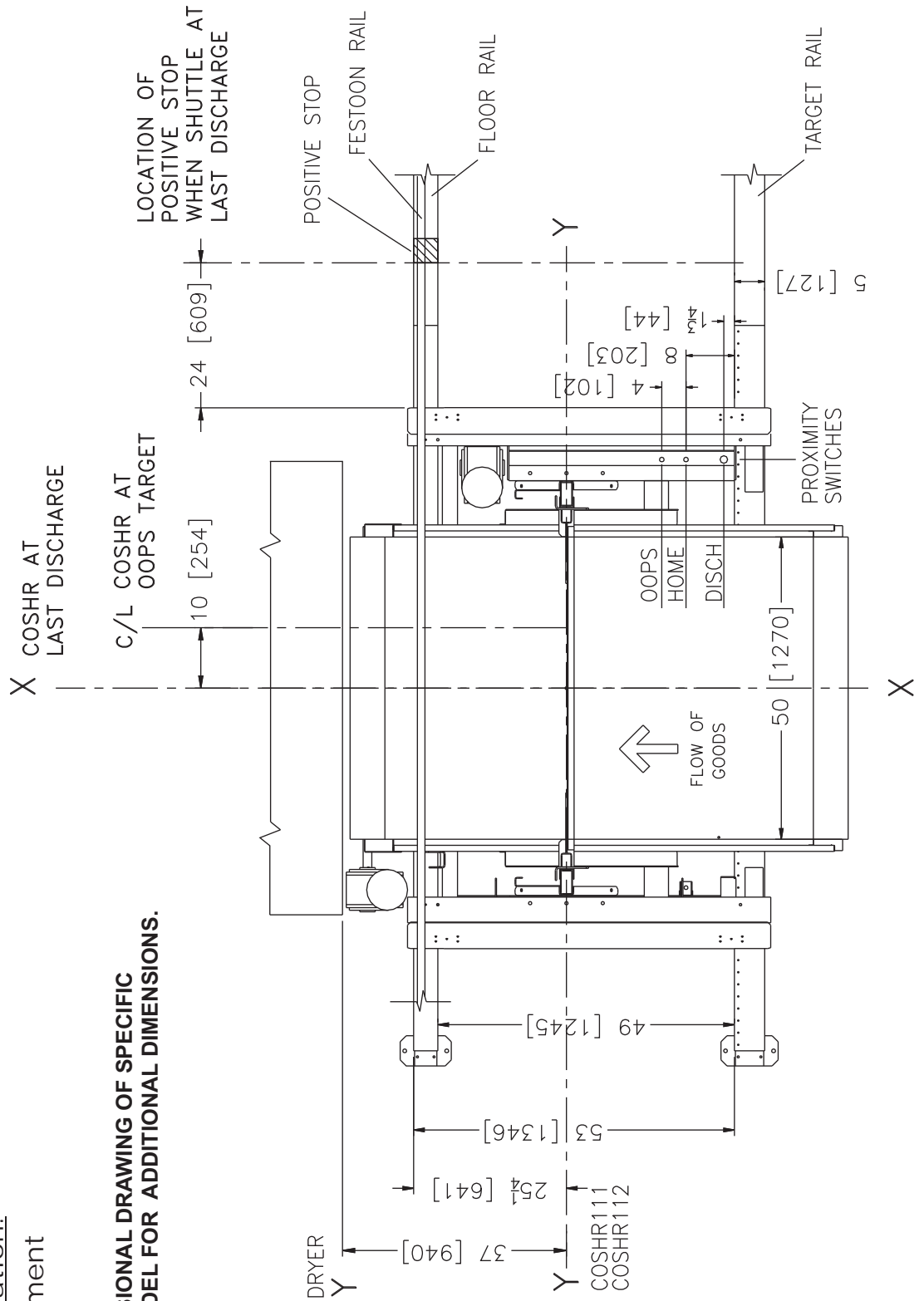
SHUTTLE RAILS MUST BE PERFECTLY PARALLEL TO DRYER FACES

- Floor rails must be parallel, level, and square along entire length of rail.

Rail Installation:

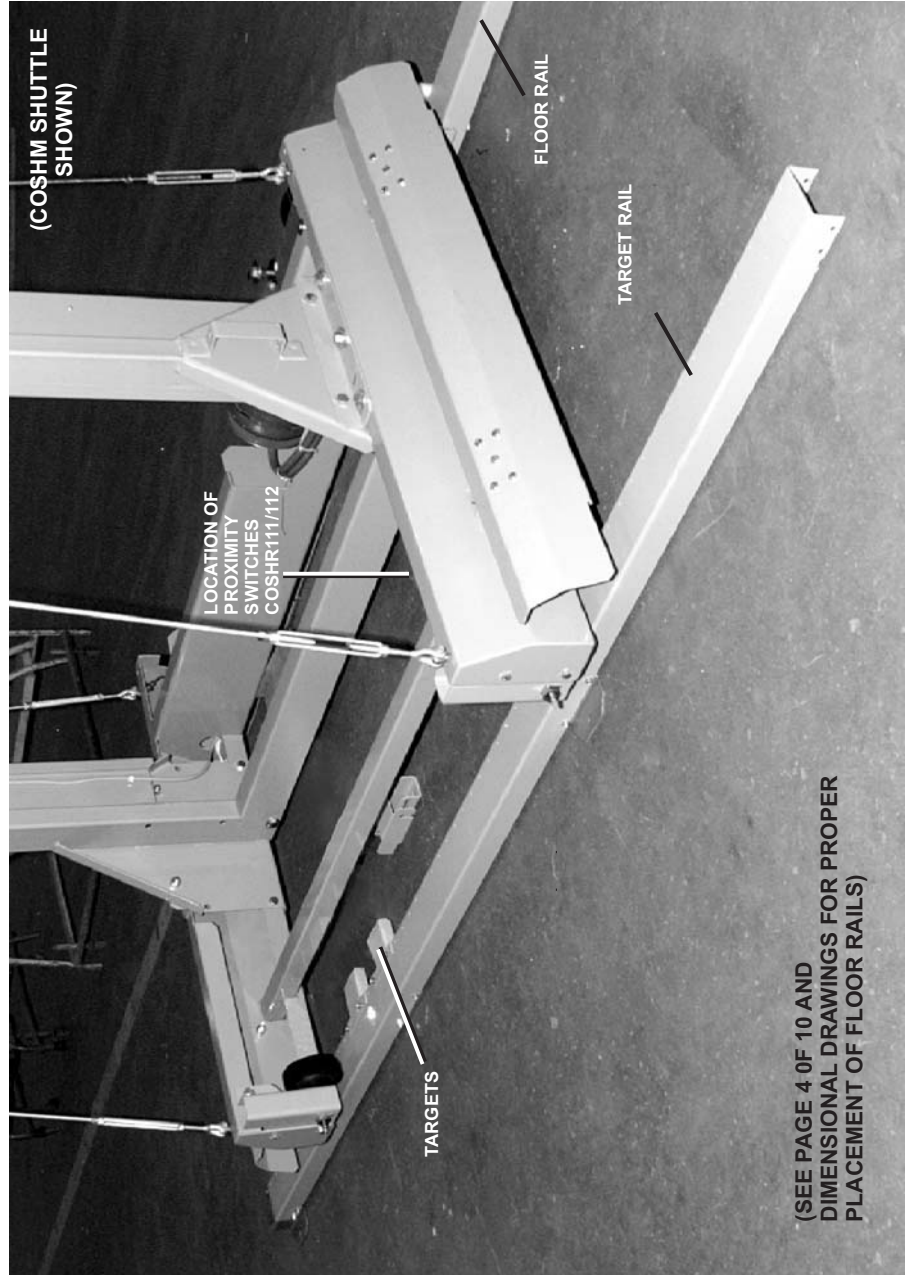
Rail Placement

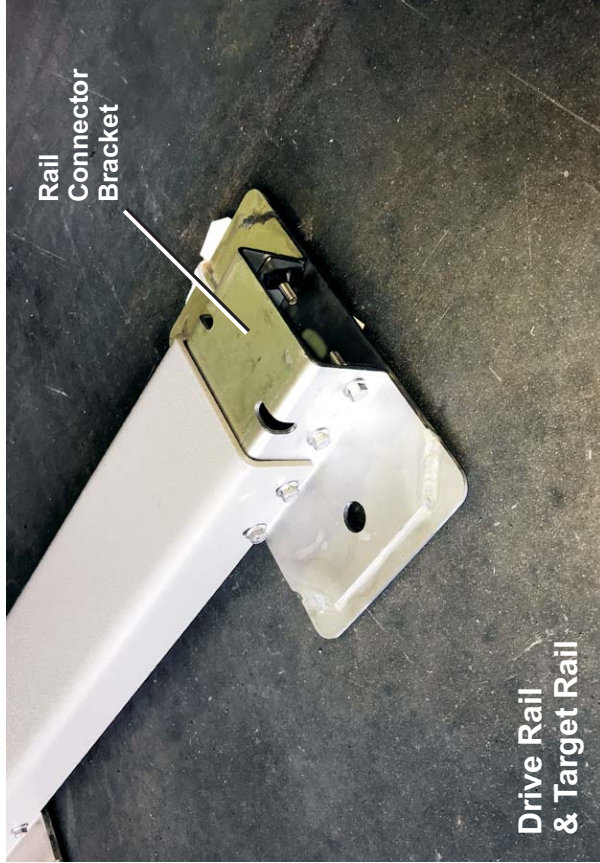
*** SEE DIMENSIONAL DRAWING OF SPECIFIC SHUTTLE MODEL FOR ADDITIONAL DIMENSIONS.**





Rail Installation:
Floor Rails





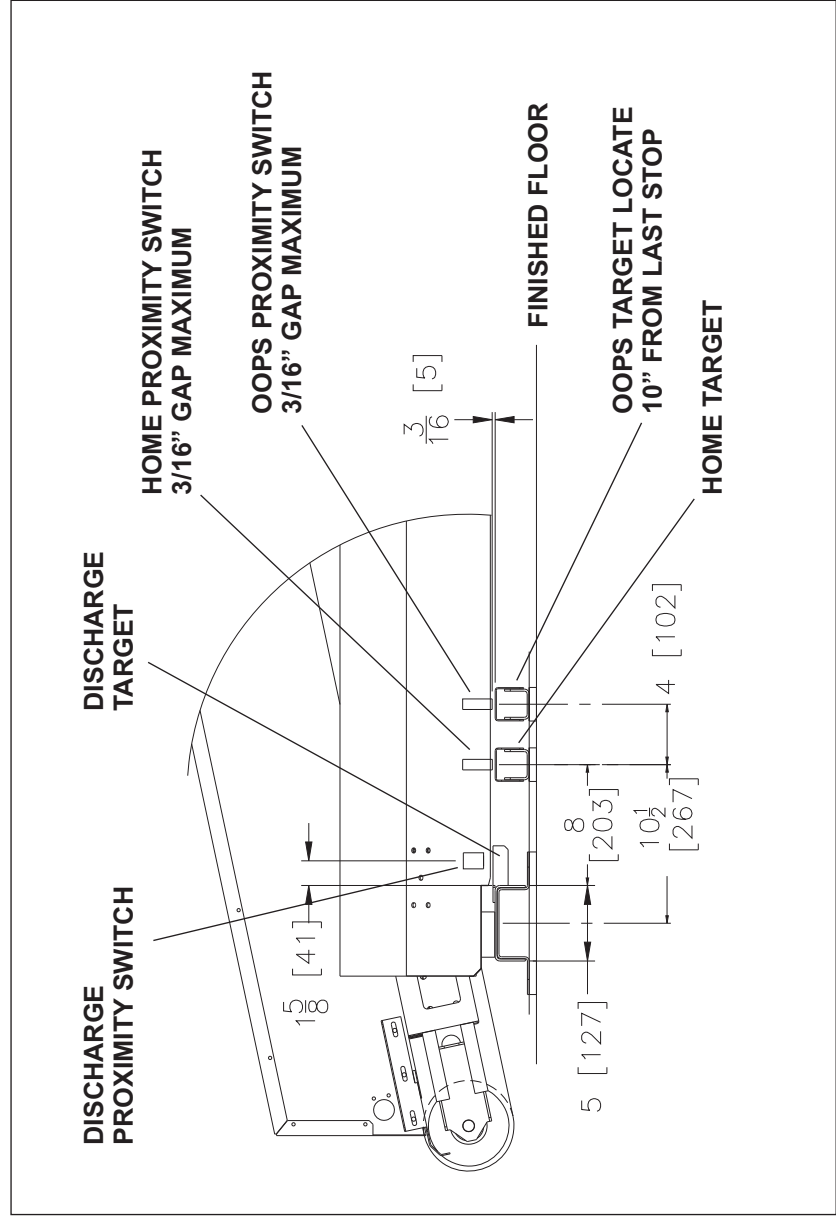
Rail Installation

Positive Stop

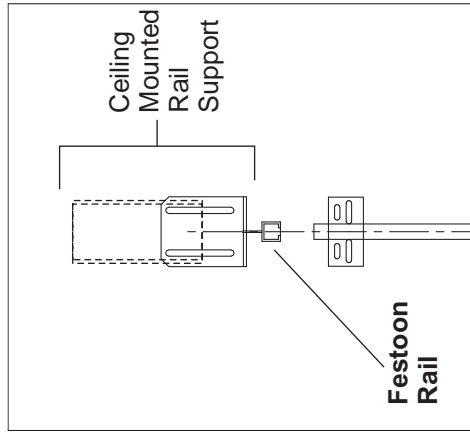


Bring Shuttle to the Last Discharge. Locate the Positive Stop 24" away from the kick plate.

Rail Installation:
Switch &
Target Settings

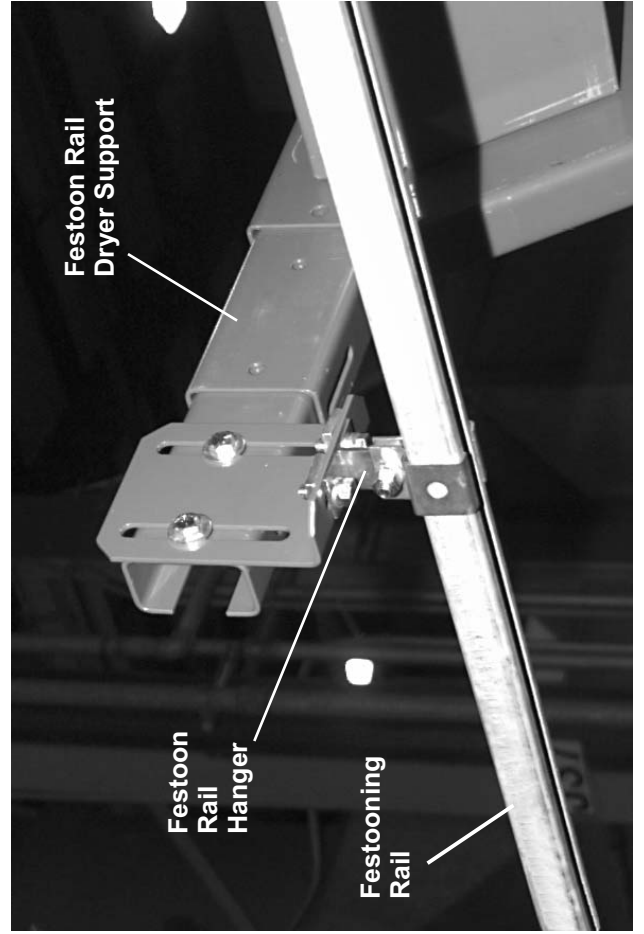


Rail Installation:
 Festooning Rail



Ceiling Mounted

Supporting the festoon rail properly is the responsibility of others. Ceiling mounted rail supports are available from Milnor. Festoon rail hanger may also be used to support rail from ceiling. Field innovation is required. See Dimensional Drawing for proper location of festoon rail.



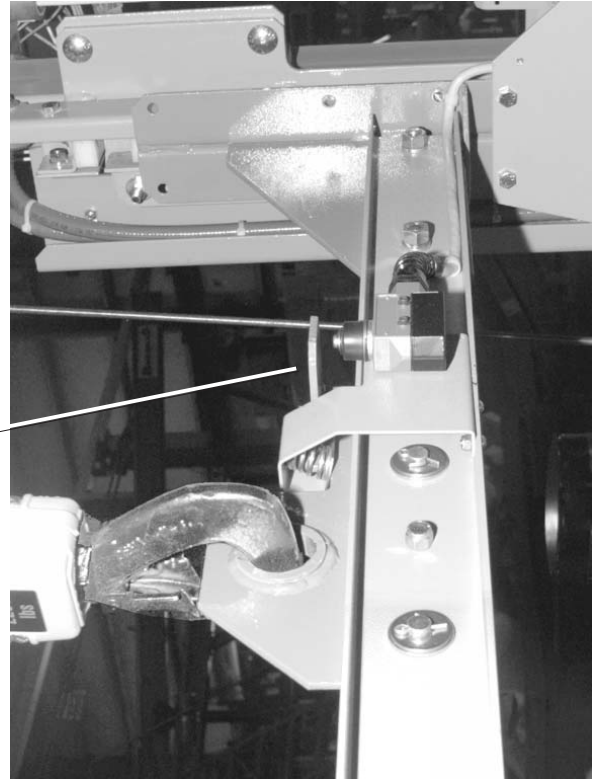


Hoist Installation:
Mounting
Chain Lubrication
Electrical Connection

Check the chain to insure it is not twisted.

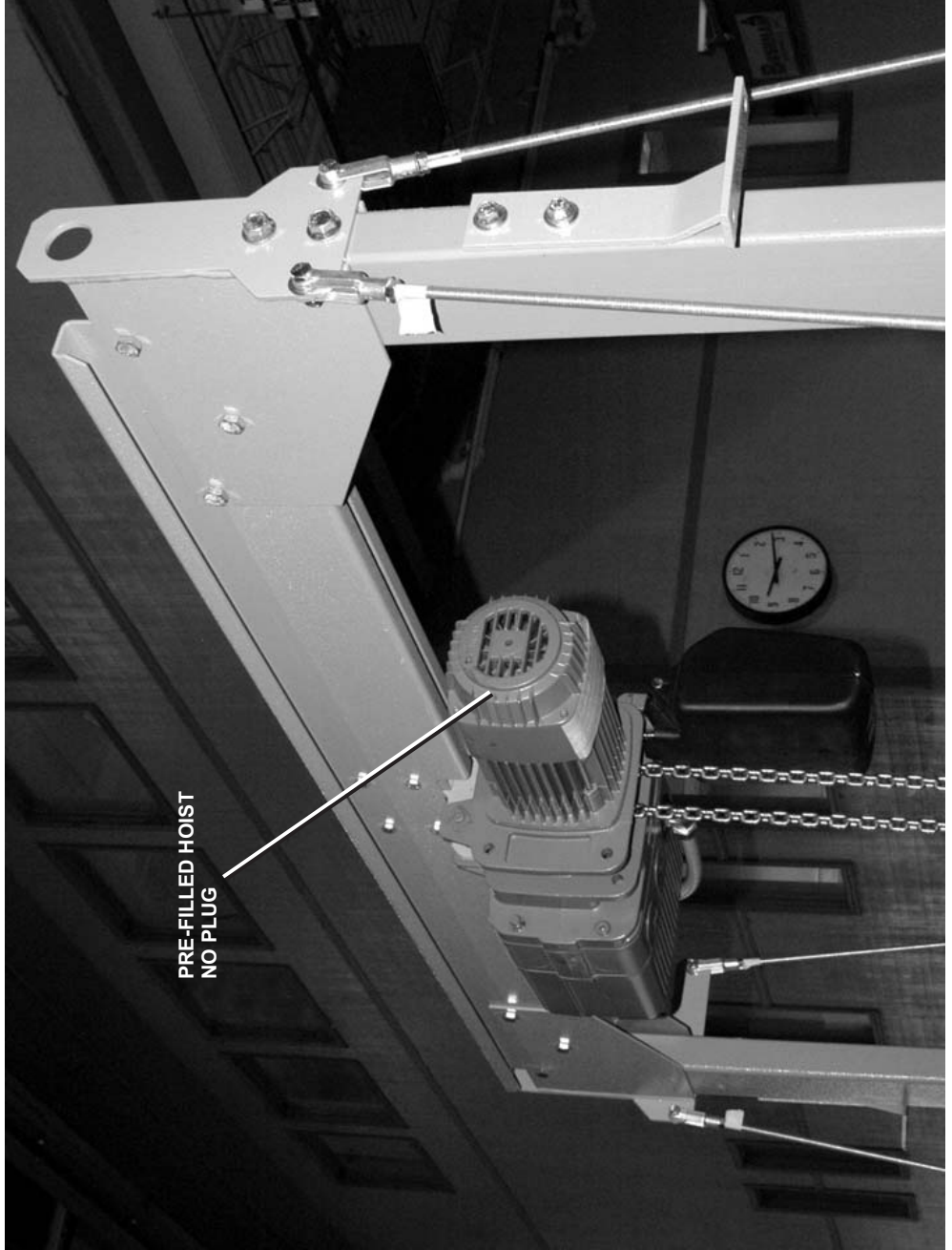
Lubricate the chain per the Maintenance Guide. See also, the hoist manufacture's manual.

CHECK LIFT PLATE PROPERLY ACTUATES LOOSE CHAIN SWITCH.



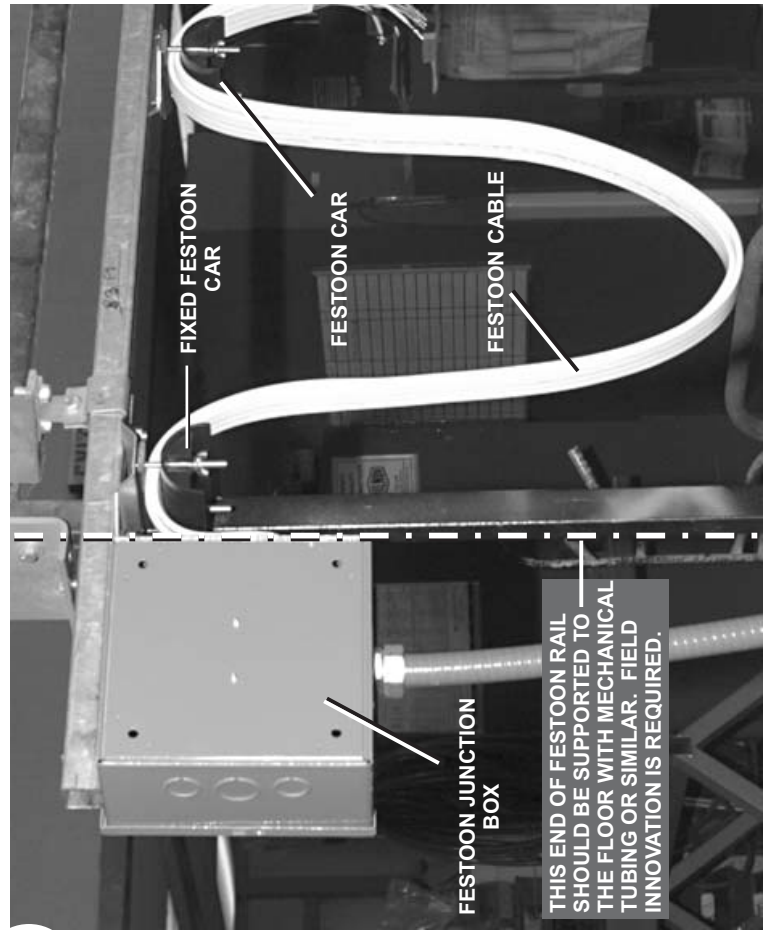
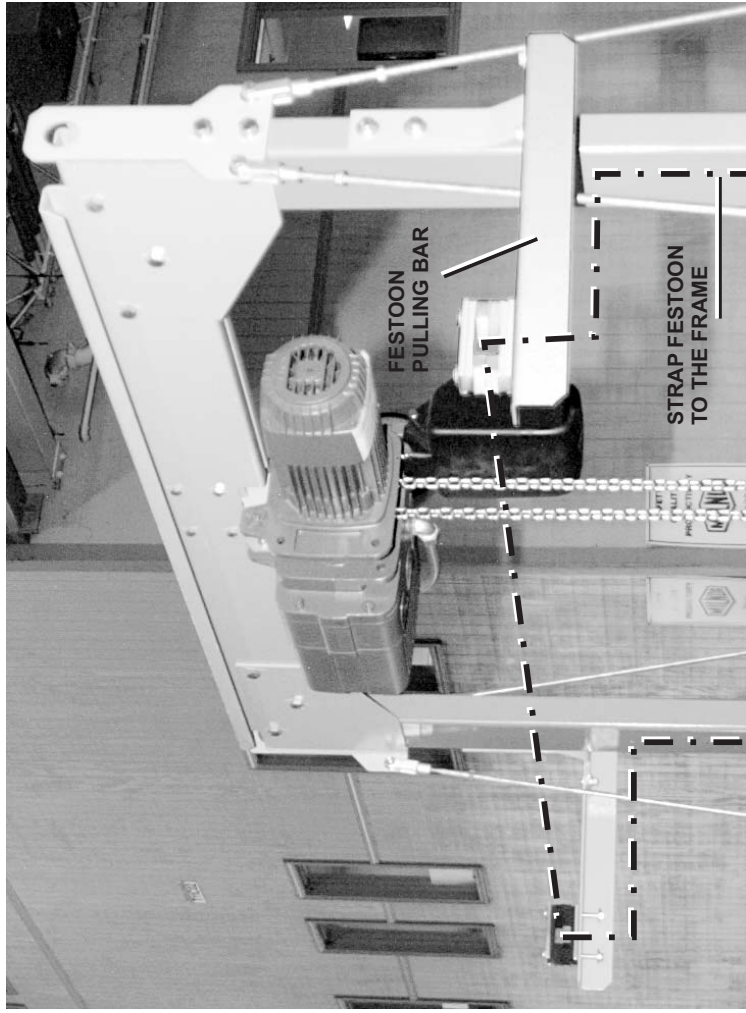


Hoist Installation:

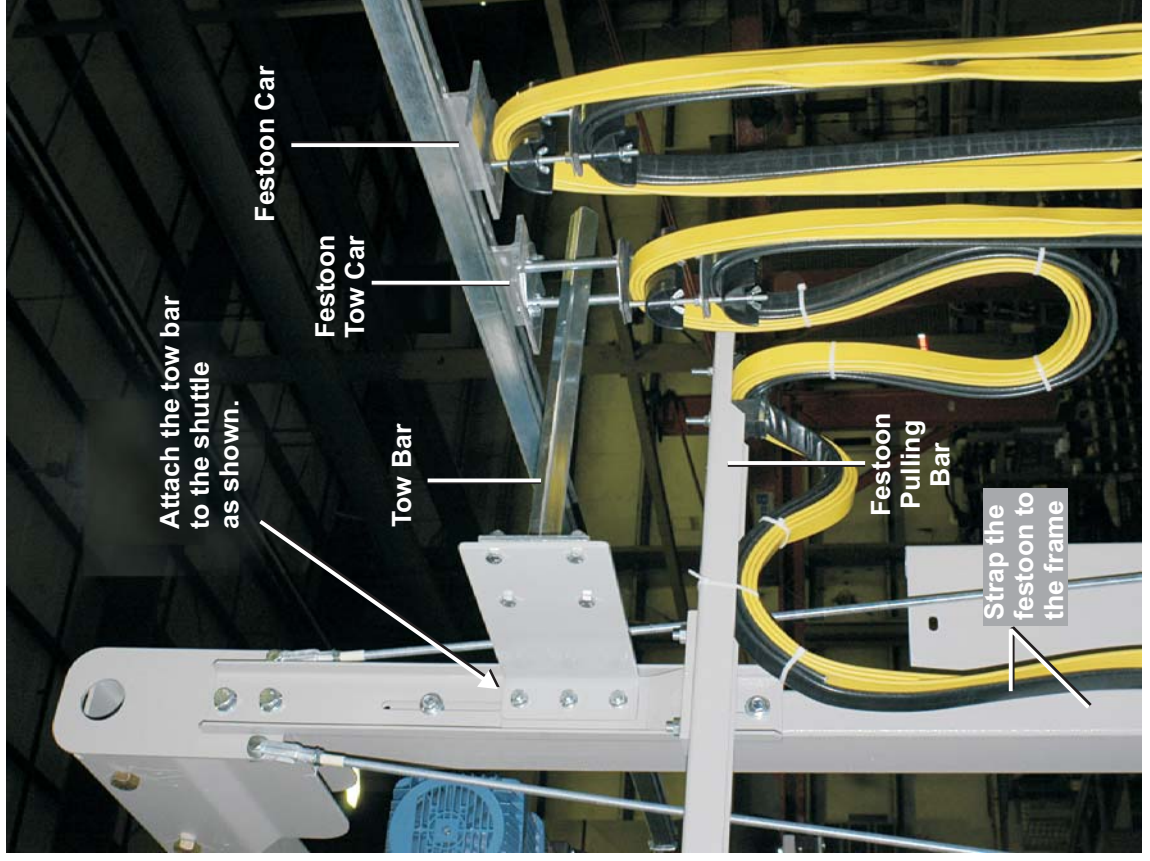


PRE-FILLED HOIST
NO PLUG

Festoon Installation:
Shuttle Festoon
Connection



Festoon Installation:
Shuttle - Festoon Connection



Installation of the Laser Positioner for Traversing Shuttles

NOTICE P1: "Remove power from the machine" means use the necessary safety procedure for your location. In the USA, this is the OSHA lockout/tagout (LOTO) procedure. More local requirements can also apply.

Milnor traversing shuttles manufactured after December 2010 are provided with a laser system to control shuttle travel along the rail (traverse) and the positions at which the shuttle stops. An older shuttle can be retrofitted with this system if it meets the following criteria:

- The system has, or is upgraded to Dryer/Shuttle controller (Drynet) software version 21010 or later and shuttle software with a matching date code.
- The shuttle has, or is upgraded to the microprocessor board with part number 08BSPE2T (2004 to current). The 08BSPE1T (circa 2000) and 08BSPET (circa 1994) will not work.
- The shuttle manual controls are housed in a stationary cabinet, not a shuttle-mounted box.

The laser positioner replaces the switches, targets, and mounting hardware previously used for this purpose. The laser positioner system uses the Banner L-Gage LT7 Laser.

1. Hardware Installation



WARNING 1: Strike and Crush Hazards—A traveling machine such as a shuttle can strike, crush, or entrap you if you ride on it or enter its path. Traveling machines or their components can move automatically in any direction. Placing a system machine on line by energizing the machine control may immediately summon a shuttle or other traveling machine.

- Except where specified in this instruction, remove power from the machine to work in or near the shuttle path.

The laser beam must be parallel with the axis of shuttle travel. Typically the laser and target are mounted approximately 7 feet (1.8 meters) above the floor and horizontally centered on the shuttle frame, but this can be modified to suit the individual circumstances. The beam must be unobstructed at all times. Locate the hardware with respect to the shuttle as follows:

Stationary laser support post—in proximity to the stationary shuttle control cabinet.

Reflector—on the shuttle frame. Detailed mounting instructions follow.

Install the hardware as shown in the figures below. It is necessary to install the laser on the support post but not anchor the post until the laser is aligned with the target.



CAUTION 2: Risk of Costly Damage—Until the laser support post is anchored, it can fall if it or the cable is hit by an object such as a fork lift. This will likely destroy the laser.

- Use care to keep clear of the post except to intentionally reposition it during alignment.
- Route the cable away from any interference and secure it.

Figure 1: Laser to Post

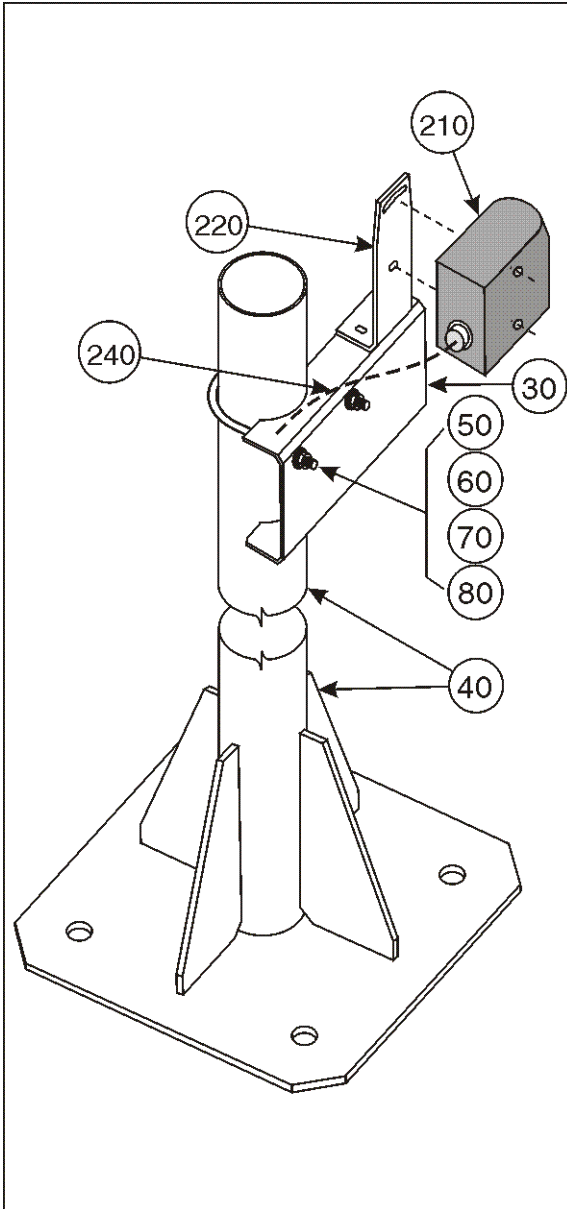


Figure 2: Reflector to Shuttle (Tube or J-rail frame)

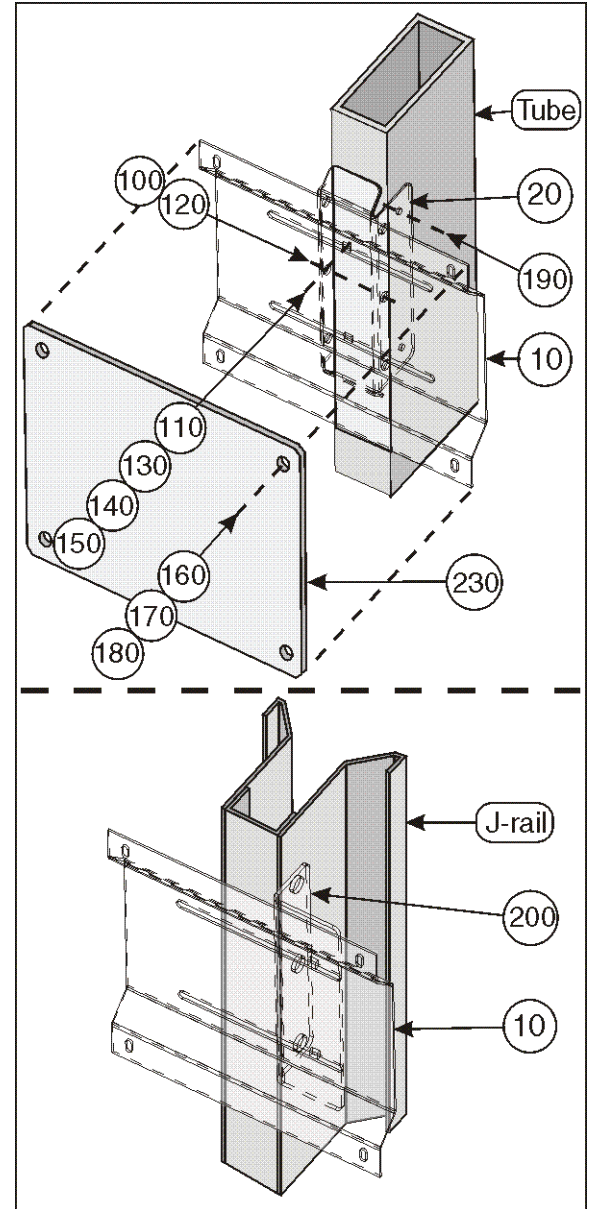


Table 1: Parts List for Figure 1 and Figure 2

Find the assembly for your machine and the letter shown in the "Item" column. The components for your machine will show this letter or the word "all" in the "Used In" column. The numbers shown in the "Item" column are those shown in the illustrations.				
Used In	Item	Part Number	Description/Nomenclature	Comments
Assemblies				
all	A	ALC420223	All mounting hardware except laser manufacturer components.	
Components				
A	10	04 24176	LASER TARGET FRAME	
A	20	04 24177	LASER TARGET TUBE RAIL MTG	Use with tubing type vertical frame member.
A	30	04 24146	LASER MTG CHANNEL	
A	40	W4 24180	LASER MOUNTING POST WLMT	
A	50	27A035C	U-BOLT 3/8-16X5.36 #0127316	
A	60	15U246	FLATWASHER 1"ODX25/64IDX1/8"30	
A	70	15U255	LOCKWASHER MEDIUM 3/8 ZINCPL	
A	80	15G205	HXNUT 3/8-16UNC2B ZINC GR2	
A	100	15A002A	CARBOLT 1/4-20UNC2X3/4 ZINC GR	
A	110	15K046	HXCAPSCR 1/4-20 UNC2A X 2"GR5	
A	120	17N058	HEXRIVNUT 1/4-20 UNC-2B #2520-	
A	130	15U185	FLATWASHER(USS STD) 1/4" ZNC P	
A	140	15U180	LOCKWASHER MEDIUM 1/4 ZINCPL	
A	150	15G178	1/4"-20 HEXFLANGE NUT ZINC	
A	160	15N125	RDMACSCR 10-24UNC2AX1/2 ZC GR2	
A	170	15U135	FLATWASH#10 .4370DX.203IDX.04T	
A	180	15G126SZ	HXLOCKNUT 10-24 UNC STL/ZNC	
A	190	15P011	TRDCUT-F PANHD 10-24X1/2 NIKST	
A	200	04 24178	LASER TARGET J-RAIL MTG	Use with J-rail vertical frame member.
all	210	09RLE0001	Banner L-Gage LT7 Laser and mounting bracket	
all	220	09RLE0001B	Mounting Bracket and included fasteners	
all	230	09RLE0001R	50 meter Retro Reflector	
all	240	09RLE0001C	Multi-conductor cable and connector—30 foot (7.6 meters) length	
	Tube	--	A type of frame used on certain shuttles	
	J-rail	--	A type of frame used on certain shuttles	

2. Electrical Connections

The electrical cable provided with this system has a pre-wired connector on one end that attaches to the laser. Shuttles manufactured after February 2011 have the control box end of the cable pre-wired also. The cable is secured to the control box. If the shuttle was not provided with the cable pre-wired, make connections as explained below. **Do not connect the cable to the laser until the wiring in the electric cabinet is completed.**

- Determine the best route for the cable. Ensure that:
 - objects cannot strike the cable,
 - there is sufficient slack on each end to reach the connection points.

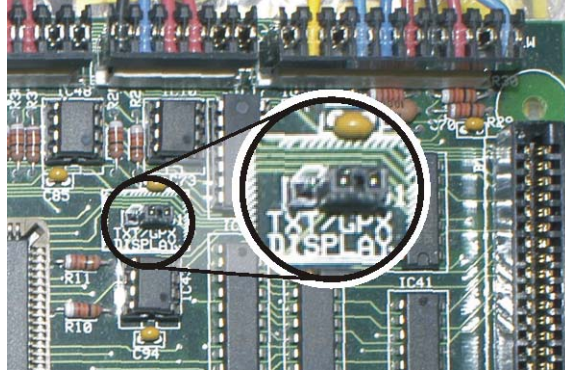
Installation of the Laser Positioner for Traversing Shuttles

2. Route the cable and secure the center portion to protect against accidental movement. If not pre-wired, route the cable into the shuttle processor box through the hole in the box shown in [Figure 3](#).
3. Set jumper J1 on the shuttle processor board to the GPX position as shown in [Figure 4](#).

Figure 3: Hole in Shuttle Processor Box for Cable

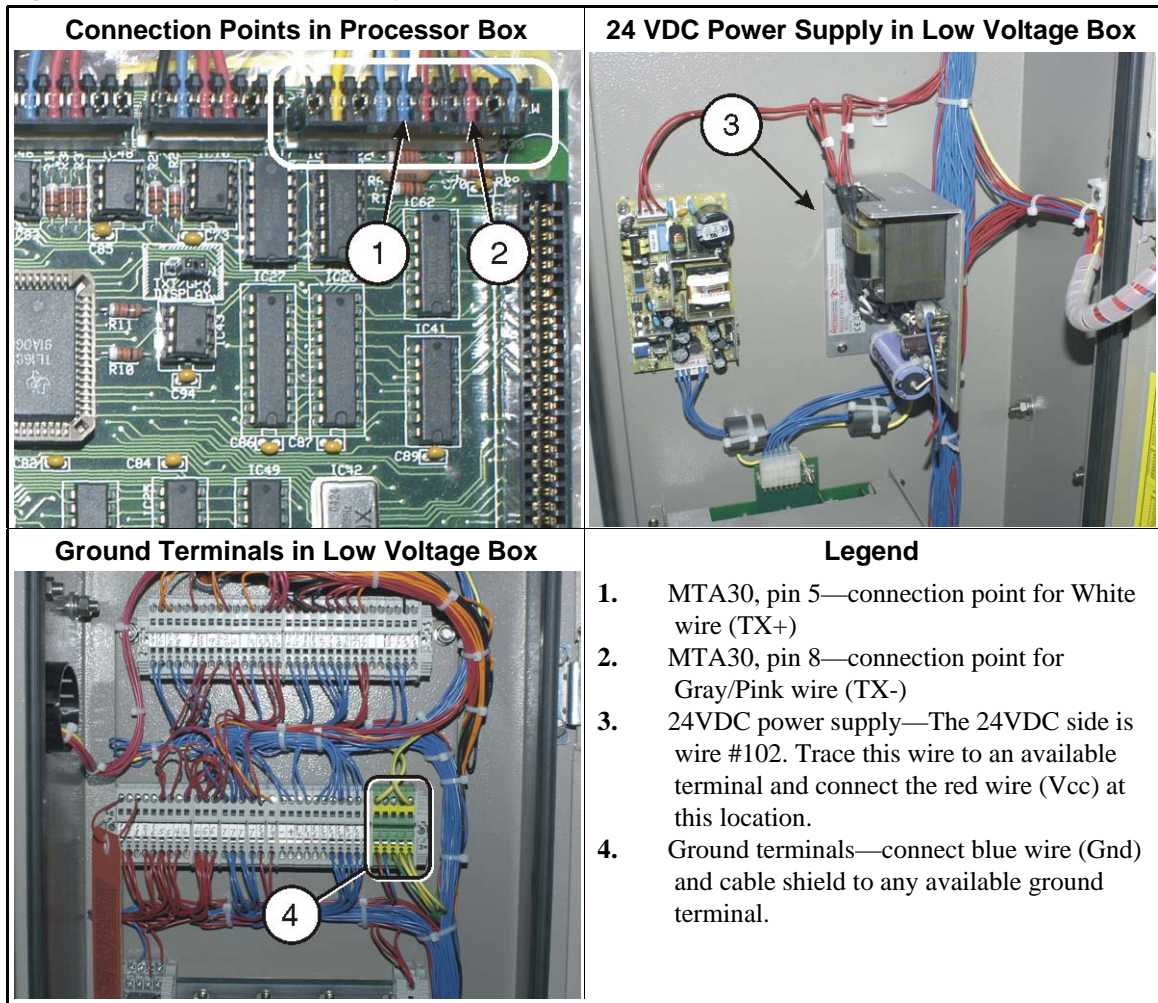


Figure 4: Jumper Position



Only four of the conductors (the green, white, red, and blue wires) and the cable shield are used for this application. If the cable must be field-wired, make electrical connections as shown in [Figure 5](#).

Figure 5: Connections—Previously Installed Shuttle



3. Configure, Align, and Program

These instructions apply specifically to Banner L-Gage LT7 laser device. You received a manual with this device. **Review the safety information in this manual.** The manual provides more information than necessary to implement the laser positioner system for the shuttle. The following sections give the pertinent instructions. You can find detailed information in the Banner manual.

Display or Action

Explanation



Energize the shuttle (at the MultiTrac or Drynet console). This will also apply power to the laser.



Set the shuttle to the Manual mode (at the stationary shuttle control panel). This will take the shuttle off line.

Perform the procedures in this section with shuttle power on, but with the machine off line. **Use extreme care when you work in or near the shuttle path.**














3.1. Laser Configuration—Required configuration settings:









Serial interface: RS422

Installation of the Laser Positioner for Traversing Shuttles

Baud rate: 19,200
 Data Bits: 8
 Stop Bits: 1
 Data method: REPEAT

At the laser device:

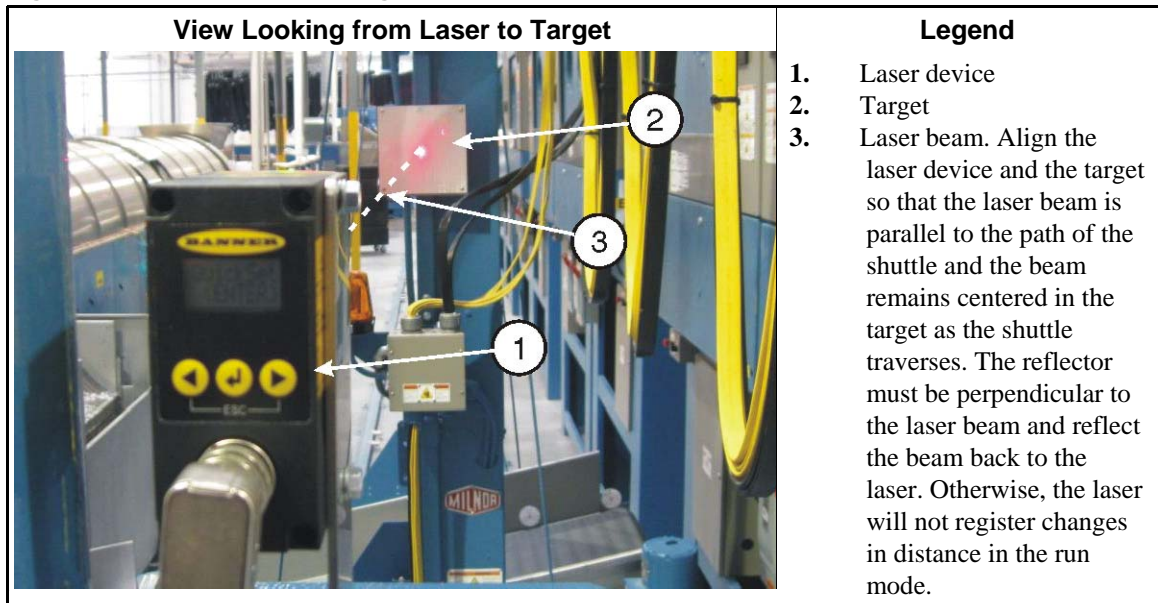
Display or Action	Explanation
<code>DIST mm</code> <code>>250000</code>	This or a similar display indicates the laser run mode. The laser displays distance in hundredths of units.
	Accesses the laser program mode. This also activates the visible pilot laser used for alignment.
<code>QuickSet</code> <code><ENTER></code>	This is the first sub-menu in the Program menu.
 ,  ...	Scrolls the sub-menus. Select "UNIT".
<code>UNIT</code> <code><mm></code>	This display indicates the laser is configured for millimeter units. You can choose millimeters or inches (<inch>). If you want to change units:
	Accesses the <i>UNIT</i> field.
<code>UNIT</code> <code>>mm</code>	You can now select inch units.
	Toggles between <i>mm</i> and <i>inch</i> each time the key is pressed.
	Locks in the selected value.
<code>UNIT</code> <code><inch></code>	Indicates that the laser is configured for inch units. When the laser is properly aligned, the Run display will show the distance between the laser and target in hundredths of inches .
 ,  ...	Scrolls the sub-menus. Select the "SERIAL" sub-menu.
<code>SERIAL</code> <code><RS422></code>	This is the display you should see and indicates that the currently configured interface type is RS422. If you see any other value on the bottom line, access this field as follows.
	Accesses the field to select the type of interface.
<code>SERIAL</code> <code>>RS422</code>	You can now select another type of interface.
 ,  ...	Scrolls the interface types, which are: RS422, SSI 1/8, SSI1/10, and EXT.BUS. Select RS422.
	Locks in the selected value.
<code>SERIAL</code> <code><RS422></code>	Indicates that the laser is configured for an RS422 interface.
	Advances to the RS422 sub-menu.
<code>RS422</code>	Because the RS422 selection has it's own sub-menu, this display appears. This

Display or Action	Explanation
<code><ENTER></code>	sub-menu has four data fields: baud rate, data bits, stop bit, and data method.
	Advances to the first field in the RS422 sub-menu: baud rate.
<code>RS422</code> <code><19k2Bd></code>	19k2Bd is the correct value. If a different value appears on the bottom line, access this field and correct the value in the same manner as above. Otherwise, proceed to the Data Bits field.
	Advances to the next field in the RS422 sub-menu: data bits.
<code>RS422</code> <code><8DATAb></code>	8DATAb is the correct value. If <code><7DATAb></code> appears on the bottom line, access this field and correct the value. Otherwise, proceed to the Stop Bits field.
	Advances to the next field: stop bits.
<code>RS422</code> <code><1STOPb></code>	1STOPb is the correct value. If <code><2STOPb></code> appears on the bottom line, access this field and correct the value. Otherwise, proceed to the data method field.
	Advances to the next field: data method.
<code>RS422</code> <code><REPEAT></code>	REPEAT is the correct value. If <code><SINGLE></code> appears on the bottom line, access this field and correct the value. Otherwise, return to the Run mode.
 +  ,	Returns to each higher-level menu, then the Run mode.
 +  . . .	

3.2. Laser and Reflector Alignment

1. At the laser device, access the program mode as previously explained. This activates the visible pilot laser used for alignment.
2. Adjust the orientation of the laser on its mounting brackets to place the beam at the center of the target.
3. Operate the shuttle in manual mode to move it along the shuttle path. Find manual operation instructions for the shuttle in the Drynet Dryer/Shuttle operator guide. As the shuttle traverses, observe the position of the beam on the target.
4. Move the laser post, and adjust the orientation of the laser and target to achieve the alignment described in [Figure 6](#).
5. When alignment is achieved, anchor the laser post to the floor.
6. When the laser post is securely anchored, check the alignment again and make final adjustments.
7. Tighten the laser and target bracketry.

Figure 6: Laser and Reflector Alignment



3.3. Drynet Configuration and Programming of Shuttle Stop Positions—The Drynet Dryer/Shuttle controller requires configure data to use the laser positioner. For example, it must know the distance between the laser and the target, as detected by the laser device, for each position at which the shuttle stops. Determine these values at the laser device. Enter this data at the Drynet or MultiTrac console, in the *Configure Shuttle Encoder* form (Figure 7).

Figure 7: Configure Shuttle Encoder Form Configured for a Laser Device

Configure Shuttle Encoder

Shuttle is currently using Laser for tracking.

Using Laser tracking: 1

Number of Load Stations:

Number of Discharge Stations:

Distance at Home Station:

Slow Down Distance:

High Speed Distance (feet):

Counts at Left Dops Target:

Counts at Right Dops Target:

Counts at Reset Point:

Stop Offset Counts:

All Decel Time: in 10th of a second

Laser Position - looking from the flow of the goods which side of the shuttle is the laser mounted: (0=Right 1=Left)

Configure Load Stations:

Distance at Load Station 0:	<input type="text" value="118"/>
Distance at Load Station 1:	<input type="text" value="0"/>
Distance at Load Station 2:	<input type="text" value="0"/>
Distance at Load Station 3:	<input type="text" value="0"/>
Distance at Load Station 4:	<input type="text" value="0"/>
Distance at Load Station 5:	<input type="text" value="0"/>
Distance at Load Station 6:	<input type="text" value="0"/>
Distance at Load Station 7:	<input type="text" value="0"/>
Distance at Load Station 8:	<input type="text" value="0"/>
Distance at Load Station 9:	<input type="text" value="0"/>
Distance at Load Station 10:	<input type="text" value="0"/>
Distance at Load Station 11:	<input type="text" value="0"/>
Distance at Load Station 12:	<input type="text" value="0"/>
Distance at Load Station 13:	<input type="text" value="0"/>
Distance at Load Station 14:	<input type="text" value="0"/>
Distance at Load Station 15:	<input type="text" value="0"/>

Configure Discharge Stations:

Distance at Discharge Station 0:	<input type="text" value="118"/>
Distance at Discharge Station 1:	<input type="text" value="201"/>
Distance at Discharge Station 2:	<input type="text" value="329"/>
Distance at Discharge Station 3:	<input type="text" value="414"/>
Distance at Discharge Station 4:	<input type="text" value="566"/>
Distance at Discharge Station 5:	<input type="text" value="0"/>
Distance at Discharge Station 6:	<input type="text" value="0"/>
Distance at Discharge Station 7:	<input type="text" value="0"/>
Distance at Discharge Station 8:	<input type="text" value="0"/>
Distance at Discharge Station 9:	<input type="text" value="0"/>
Distance at Discharge Station 10:	<input type="text" value="0"/>
Distance at Discharge Station 11:	<input type="text" value="0"/>
Distance at Discharge Station 12:	<input type="text" value="0"/>
Distance at Discharge Station 13:	<input type="text" value="0"/>
Distance at Discharge Station 14:	<input type="text" value="0"/>
Distance at Discharge Station 15:	<input type="text" value="0"/>

1. At the MultiTrac or Drynet console, access the shuttle Encoder form:
 - a. In the Dryer/Shuttle Controller (DevComm Setup) window, select *Configure, Shuttles and Cobucs* on the menu. This displays one or more tabbed forms—one for each shuttle device in the system.
 - b. Select the tab corresponding to the shuttle with the new laser device. This displays the main configuration form for this shuttle.
 - c. Near the bottom right of the form, find the field *Shuttle has an Encoder*. Select (or re-select) the value 1. This displays the *Configure Shuttle Encoder* form (Figure 7).
2. Enter values in the fields on the left column of the encoder form in accordance with Table 2.
3. Do this procedure for each position at which the shuttle stops:
 - a. At the stationary shuttle control box, manually move the shuttle to the stop position. Ensure that the shuttle is precisely aligned with the interfacing device.
 - b. At the laser device, read the distance value in hundredths of units (inches or millimeters as previously configured). Hence, read the displayed value 26147 as 261 inches or millimeters.
 - c. At the Drynet controller, enter this value (whole inches or millimeters) in the appropriate field:
 - Distance at Home Station
 - Distance at Load Station ____
 - Distance at Discharge Station ____

Table 2: Guidelines for Encoder Values for Laser Device

Data Field	Required Value or Guideline
Using laser tracking	1
Number of Load Stations	Per physical layout
Number of Discharge Stations	Per physical layout
Distance at Home Station	See Item 3 below.
Slow Down Distance	Between 6 and 10 inches (152 and 254 mm) recommended
High Speed Distance (feet)	Not currently implemented
Counts at Left Oops Target	Disabled and not applicable to laser device.
Counts at Right Oops Target	
Counts at Reset Point	
Stop Offset Counts	0
At Decel Time: in 10ths of a second	0
Laser Position	Face the direction that goods move as they are loaded onto the shuttle bed. If the post-mounted laser is located to the right of the shuttle, enter 0. If to the left of the shuttle, enter 1.

4. Testing

When you have entered all shuttle stop positions in the Drynet controller, test each position as explained in document BIVSRC01 "How to Test Traversing Shuttle Stop Positions."

— End of BIVSVI01 —

Service and Maintenance

3

Shuttle Preventive Maintenance

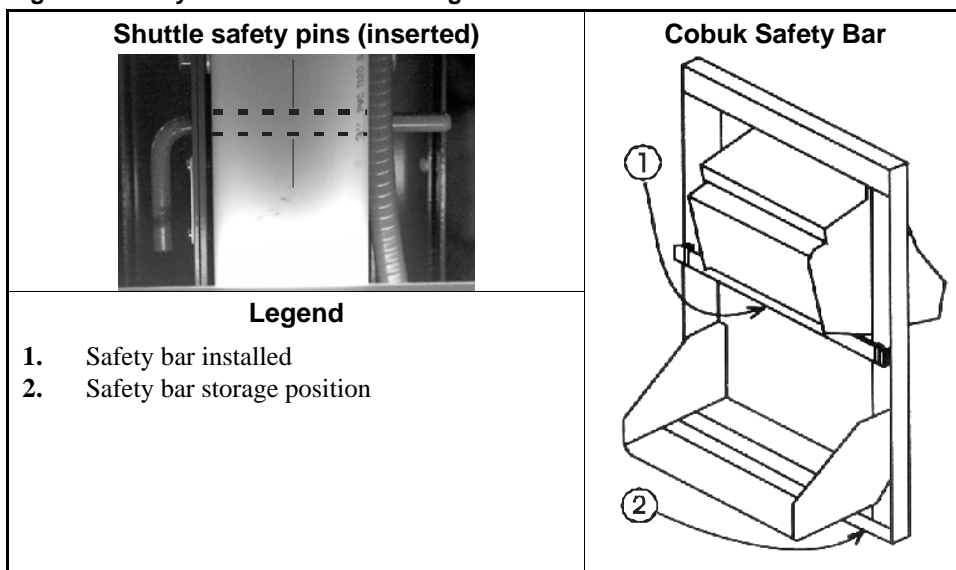
1. General Information



WARNING [1]: Crush Hazards—A traveling machine such as a shuttle can crush or entrap you if the bed or bucket descends while you are under it. The bed or bucket can descend with power off or on.

- Secure both red safety pins in accordance with the instructions furnished, then lock out and tag out power at the main machine disconnect before working under bed or bucket.

Figure 1: Safety Pin/Bar Use and Storage



2. Lubrication Precautions [Document BIUUM01]



CAUTION [2]: Machine Damage Hazard—Improper lubrication can damage machine components and cause the machine to malfunction.

- Do not mix petroleum and synthetic based lubricants.
- Do not use an unspecified lubricant without consulting the lubricant manufacturer.
- Do not apply grease with a pneumatic grease gun. Use only a hand-operated grease gun.
- Do not over-lubricate.
- Always clean grease fittings before adding grease. Clean off excess grease.
- Ensure that lubricants do not drip onto belts, brake shoes or drums.



WARNING [3]: Entangle and Crush Hazards—Contact with moving components normally isolated by guards, covers, and panels, can entangle and crush your limbs. These components move automatically.

- Abide by the current OSHA lockout/tagout standard when lockout/tagout is called for in the service instructions. Outside the USA, abide by the OSHA standard in the absence of any other overriding standard.
- Do not service the machine unless qualified and authorized. You must clearly understand

the hazards and how to avoid them.

- 2.1. **Pumping Grease**—Pump grease slowly, taking 10-12 seconds to complete each stroke. A grease gun can build up extremely high pressure which will force seals out of position and cause them to leak.
- 2.2. **Grease Quantity**—Apply the quantity of grease called for in the checklist. Over-lubrication can be as damaging as under-lubrication. Where quantities are stated in strokes, one stroke of the grease gun is assumed to provide .0624 fluid oz. (1.77 grams) (by volume) of grease. Therefore, one fluid ounce (28.3 grams) of grease would be provided by 16 strokes of the grease gun. Determine the flow rate of your grease gun by pumping one ounce into a calibrated container. If fewer than 16 strokes are required, all quantities in strokes in the chart should be reduced accordingly, and if more than 16 strokes are required, the number of strokes should be increased. Before starting lubrication, make sure your grease gun is working and that you get a full charge of grease with every stroke.
- 2.3. **Lubricant Specifications**—Lubricant specifications are provided in the preventive maintenance checklist. Lubricants should be purchased locally. If a specified lubricant is not available locally, it is permissible to substitute a product that has been specified as equivalent by the lubricant manufacturer. If you cannot obtain either the specified lubricant or a valid equivalent locally, contact the Milnor Service Department for assistance.

3. Routine Maintenance

Table 1: Preventive Maintenance Checklist

Component	Procedure	Frequency	Lubricant/Figure	
Hoist assembly				
Hoist fasteners	Inspect fasteners and clips for tightness and corrosion	Annually	Figure 2	
Suspension eye	Inspect and apply grease	Annually	DG 68 gear grease, Figure 2	
Chain	Lubricate	Every six months	DG 68 gear grease, See the manufacturer's manual for additional information.	
	Check chain for deformation, damage, cracks, pitting, reduction in the thickness of the links, increase in pitch due to wear, elongation caused by deformation.	Annually		
	Check chain sprocket, return sprocket and chain guides for wear.	Annually		
	Check chain collector box fasteners for tightness	Annually		Figure 2
	Lubricate the hook assembly sprocket bearing. Check fasteners for tightness.	Annually		DG 68 gear grease, Figure 2
Hook Assembly	Check hook bearing for wear	Annually	Figure 2	
	Check hook for cracks, deformation and wear	Annually		
Bed Lifting Frame	Check channels, frame and sliding pads for wear. Check fastener tightness and corrosion. Test loose chain switch operation.	Annually	Figures 2 and 3	
Shuttle Belts	Check condition, tension and tracking. Adjust as necessary.	Weekly	Figure 3	
Clutch	Check for clutch slippage	Annually		
Brake	Check for slippage	Annually		
Brake	Check the brake stroke, adjust the brake or replace the brake cup, as required.	Annually	See the manufacturer's manual for additional information	
Oil reservoir	Check oil level	Annually	Shell Omala 220 (or equivalent), Figure 2	
	Change oil	Every 4 - 5 years		
Hoist motor bearings	Check for corrosion	Every 5 years	See the manufacturer's manual for additional information.	
Electrical components	Check control wiring for damage.	Annually	Figure 3	
	Check the cable strain relief.			
	Test the emergency stop switches.			

Component	Procedure	Frequency	Lubricant/Figure
Rail wheel grease points	Slowly grease 2 strokes, 0.12 ounces (3.54 grams) at multiple locations	Every 6 weeks	Figure 3
Conveyor roller grease points	Slowly grease 2 strokes, 0.12 ounces (3.54 grams) at multiple locations	Every 6 weeks	Figure 3

Figure 2: Hoist Maintenance Points


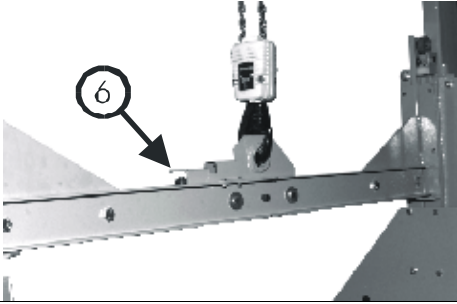

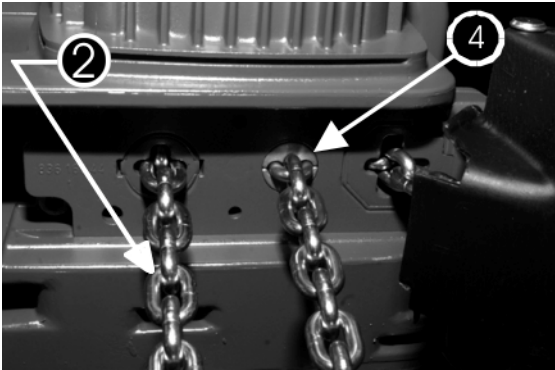

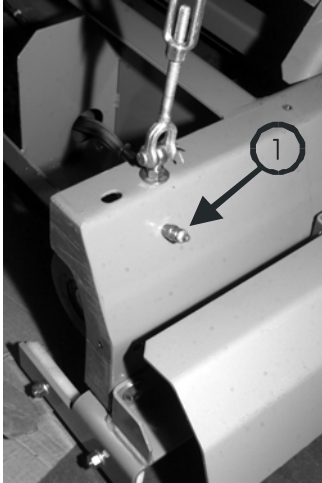

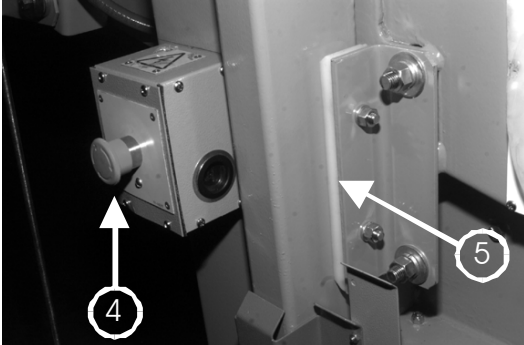
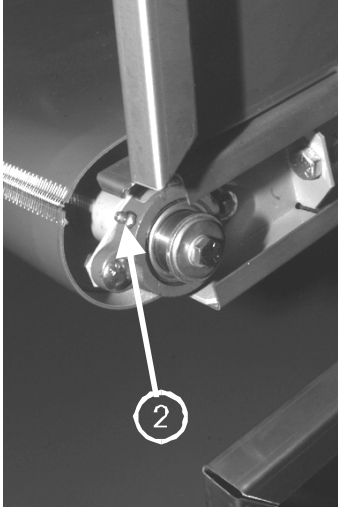
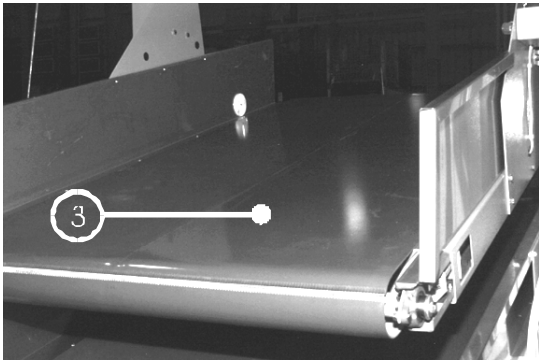
<p>Hoist Mounting Pin</p> 	<p>Bed Lifting Frame</p>  <p>Legend</p> <ol style="list-style-type: none"> 1. Check hoist mounting pin (17A097) and retaining cotter key (15H060) 2. Grease chain per hoist manufacturer's recommendations 4. Suspension eye 5. Collector supports 6. Loose chain switch 	<p>Hook Assembly</p> 
<p>Suspension Eye and Chain</p> 		<p>Chain Collector</p> 

Figure 3: Shuttle Maintenance Points

<p>Discharge side rail grease wheel point</p> 	<p>Load side rail wheel grease point</p>  <p>Emergency stop and sliding pads</p> 	<p>Legend</p> <ul style="list-style-type: none">1. Rail wheel grease point2. Roller grease point3. Belt condition, tension and tracking4. Stop switch5. Sliding pads6. Rail wheel grease point
<p>Conveyor roller grease point</p> 	<p>Shuttle bed belts</p> 	

— End of BIVUUM01 —

Torque Requirements for Fasteners



This document uses Simplified Technical English. Learn more at <http://www.asd-ste100.org>.

The document about the assembly gives the torque requirements for other fasteners. **If fastener torque specifications or threadlocker requirements in an assembly document are different from this document, use the assembly document.**

Figure 1: The Bolts in Milnor® Equipment

The Marks on Bolt Heads	Legend
	<p>A. SAE Grades 1 and 2, ASTM A307, and stainless steel</p> <p>B. Grade BC, ASTM A354</p> <p>C. SAE Grade 5, ASTM A449</p> <p>D. SAE Grade 8 and ASTM A354 BD</p>

1. Torque Values

These tables give the standard dimension, grade, threadlocker, and torque requirements for fasteners frequently used on Milnor® equipment.

Note 1: Data from the Pellerin Milnor® Corporation “Bolt Torque Specification” (bolt_torque_milnor.xls/2002096).

1.1. Fasteners Made of Carbon Steel

1.1.1. Without a Threadlocker

Table 1: Torque Values for Standard Fasteners with Maximum 5/16-inch Diameters and No Lubricant

Dimension	The Grade of the Bolt							
	Grade 2		Grade 5		Grade 8		Grade BC	
	Pound-Inches	N-m	Pound-Inches	N-m	Pound-Inches	N-m	Pound-Inches	N-m
1/4 x 20	66	7	101	11	143	16	126	14
1/4 x 28	76	9	116	13	163	18	--	--
5/16 x 18	136	15	209	24	295	33	258	29
5/16 x 24	150	17	232	26	325	37	--	--

Torque Requirements for Fasteners

Table 2: Torque Values for Standard Fasteners Larger Than 5/16-inch Diameters and No Lubricant

Dimension	The Grade of the Bolt							
	Grade 2		Grade 5		Grade 8		Grade BC	
	Pound-feet	N-m	Pound-feet	N-m	Pound-feet	N-m	Pound-feet	N-m
3/8 x 16	20	27	31	42	44	59	38	52
3/8 x 24	23	31	35	47	50	68	--	--
7/16 x 14	32	43	49	66	70	95	61	83
7/16 x 20	36	49	55	75	78	105	--	--
1/2 x 13	49	66	75	102	107	145	93	126
1/2 x 20	55	75	85	115	120	163	--	--
9/16 x 12	70	95	109	148	154	209	134	182
9/16 x 18	78	106	121	164	171	232	--	--
5/8 x 11	97	131	150	203	212	287	186	252
5/8 x 18	110	149	170	231	240	325	--	--
3/4 x 10	172	233	266	361	376	510	329	446
3/4 x 16	192	261	297	403	420	569	--	--
7/8 x 9	167	226	429	582	606	821	531	719
7/8 x 14	184	249	473	641	668	906	--	--
1 x 8	250	339	644	873	909	1232	796	1079
1 x 12	274	371	704	954	994	1348	--	--
1 x 14	281	381	723	980	1020	1383	--	--
1 1/8 x 7	354	480	794	1077	1287	1745	1126	1527
1 1/8 x 12	397	538	891	1208	1444	1958	--	--
1 1/4 x 7	500	678	1120	1519	1817	2464	1590	2155
1 1/4 x 12	553	750	1241	1682	2012	2728	--	--
1 3/8 x 6	655	888	1469	1992	2382	3230	2085	2827
1 3/8 x 12	746	1011	1672	2267	2712	3677	--	--
1 1/2 x 6	869	1178	1949	2642	3161	4286	2767	3751
1 1/2 x 12	979	1327	2194	2974	3557	4822	--	--

Table 3: Torque Values for Plated Fasteners with Maximum 5/16-inch Diameters and No Lubricant

Dimension	The Grade of the Bolt							
	Grade 2		Grade 5		Grade 8		Grade BC	
	Pound-Inches	N-m	Pound-Inches	N-m	Pound-Inches	N-m	Pound-Inches	N-m
1/4 x 20	49	6	76	9	107	12	95	11
1/4 x 28	56	6	88	10	122	14	--	--
5/16 x 18	102	12	156	18	222	25	193	22
5/16 x 24	113	13	174	20	245	28	--	--

Table 4: Torque Values for Plated Fasteners Larger Than 5/16-inch Diameters and No Lubricant

Dimension	The Grade of the Bolt							
	Grade 2		Grade 5		Grade 8		Grade BC	
	Pound-feet	N-m	Pound-feet	N-m	Pound-feet	N-m	Pound-feet	N-m
3/8 x 16	15	20	23	31	33	44	29	38
3/8 x 24	17	23	26	35	37	49	--	--
7/16 x 14	24	32	37	50	52	71	46	61
7/16 x 20	27	36	41	55	58	78	--	--
1/2 x 13	37	49	56	76	80	106	70	93
1/2 x 20	41	55	64	85	90	120	--	--
9/16 x 12	53	70	81	110	115	153	101	134
9/16 x 18	59	79	91	122	128	174	--	--
5/8 x 11	73	97	113	150	159	212	139	186
5/8 x 18	83	110	127	172	180	240	--	--
3/4 x 10	129	173	200	266	282	376	246	329
3/4 x 16	144	192	223	297	315	420	--	--
7/8 x 9	125	166	322	430	455	606	398	531
7/8 x 14	138	184	355	474	501	668	--	--
1 x 8	188	250	483	644	682	909	597	796
1 x 12	205	274	528	716	746	995	--	--
1 x 14	210	280	542	735	765	1037	--	--
1 1/8 x 7	266	354	595	807	966	1288	845	1126
1 1/8 x 12	298	404	668	890	1083	1444	--	--
1 1/4 x 7	375	500	840	1120	1363	1817	1192	1590
1 1/4 x 12	415	553	930	1261	1509	2013	--	--
1 3/8 x 6	491	655	1102	1470	1787	2382	1564	2085
1 3/8 x 12	559	758	1254	1672	2034	2712	--	--
1 1/2 x 6	652	870	1462	1982	2371	3161	2075	2767
1 1/2 x 12	733	994	1645	2194	2668	3557	--	--

1.1.2. With a Threadlocker

Table 5: Threadlocker by the Diameter of the Bolt (see Note 2)

LocTite Product	Dimension			
	1/4-inch	1/4- to 5/8-inch	5/8- to 7/8-inch	1-inch +
LocTite 222	OK			
LocTite 242		OK		
LocTite 262			OK	
LocTite 272			High temperature	
LocTite 277				OK

Note 2: The acceptable bolt size ranges for various LocTite® threadlocking products is the LocTite manufacturer's **general** recommendation. Specific applications sometime require that a LocTite product is applied to a bolt size outside the ranges shown here. For example, Milnor specifies LocTite 242 for use on certain 1" bolt applications and has confirmed this usage with the LocTite manufacturer. You may see variances such as this in the documentation for specific machine assemblies.

Torque Requirements for Fasteners

Table 6: Torque Values if You Apply LocTite 222

Dimension	The Grade of the Bolt							
	Grade 2		Grade 5		Grade 8		Grade BC	
	Pound-inches	N-m	Pound-inches	N-m	Pound-inches	N-m	Pound-inches	N-m
1/4 x 20	60	7	96	11	132	15	108	12
1/4 x 28	72	8	108	12	144	16	--	--

Table 7: Torque Values if You Apply LocTite 242

Dimension	The Grade of the Bolt							
	Grade 2		Grade 5		Grade 8		Grade BC	
	Pound-feet	N-m	Pound-feet	N-m	Pound-feet	N-m	Pound-feet	N-m
5/16 x 18	11	15	17	23	25	34	22	30
5/16 x 24	13	18	19	26	27	37	27	37
3/8 x 16	20	27	31	42	44	60	38	52
3/8 x 24	23	31	35	47	50	68	--	--
7/16 x 14	32	43	49	66	70	95	61	83
7/16 x 20	36	49	55	75	78	106	--	--
1/2 x 13	49	66	75	102	107	145	93	126
1/2 x 20	55	75	85	115	120	163	--	--
9/16 x 12	70	95	109	148	154	209	134	182
9/16 x 18	78	106	121	164	171	232	--	--
5/8 x 11	97	132	150	203	212	287	186	252
5/8 x 18	110	149	170	230	240	325	--	--

Table 8: Torque Values if You Apply LocTite 262

Dimension	The Grade of the Bolt							
	Grade 2		Grade 5		Grade 8		Grade BC	
	Pound-feet	N-m	Pound-feet	N-m	Pound-feet	N-m	Pound-feet	N-m
3/4 x 10	155	210	240	325	338	458	296	401
3/4 x 16	173	235	267	362	378	512	--	--
7/8 x 9	150	203	386	523	546	740	477	647
7/8 x 14	165	224	426	578	601	815	--	--

Table 9: Torque Values if You Apply LocTite 272 (High-Temperature)

Dimension	The Grade of the Bolt							
	Grade 2		Grade 5		Grade 8		Grade BC	
	Pound-feet	N-m	Pound-feet	N-m	Pound-feet	N-m	Pound-feet	N-m
1 x 8	350	475	901	1222	1272	1725	1114	1510
1 x 12	383	519	986	1337	1392	1887	--	--
1 x 14	393	533	1012	1372	1428	1936	--	--
1-1/8 x 7	496	672	1111	1506	1802	2443	1577	2138
1-1/8 x 12	556	754	1247	1691	2022	2741	--	--
1-1/4 x 7	700	949	1568	2126	2544	3449	2226	3018
1-1/4 x 12	774	1049	1737	2355	2816	3818	--	--
1-3/8 x 6	917	1243	2056	2788	3335	4522	2919	3958
1-3/8 x 12	1044	1415	2341	3174	3797	5148	--	--
1-1/2 x 6	1217	1650	2729	3700	4426	6001	3873	5251
1-1/2 x 12	1369	1856	3071	4164	4980	6752	--	--

Table 10: Torque Values if You Apply LocTite 277

Dimension	The Grade of the Bolt							
	Grade 2		Grade 5		Grade 8		Grade BC	
	Pound-feet	N-m	Pound-feet	N-m	Pound-feet	N-m	Pound-feet	N-m
1 x 8	325	441	837	1135	1181	1601	1034	1402
1 x 12	356	483	916	1242	1293	1753	--	--
1 x 14	365	495	939	1273	1326	1798	--	--
1-1/8 x 7	461	625	1032	1399	1674	2270	1464	1985
1-1/8 x 12	516	700	1158	1570	1877	2545	--	--
1-1/4 x 7	650	881	1456	1974	2362	3202	2067	2802
1-1/4 x 12	719	975	1613	2187	2615	3545	--	--
1-3/8 x 6	851	1154	1909	2588	3097	4199	2710	3674
1-3/8 x 12	970	1315	2174	2948	3526	4781	--	--
1-1/2 x 6	1130	1532	2534	3436	4110	5572	3597	4877
1-1/2 x 12	1271	1723	2852	3867	4624	6269	--	--

1.2. Stainless Steel Fasteners

Table 11: Torque Values for Stainless Steel Fasteners 5/16-inch and Smaller

Dimension	316 Stainless		18-8 Stainless		18-8 Stainless with Loctite 767	
	Pound-Inches	N-m	Pound-Inches	N-m	Pound-Inches	N-m
1/4 x 20	79	9	76	9	45	5
1/4 x 28	100	11	94	11	56	6
5/16 x 18	138	16	132	15	79	9
5/16 x 24	148	17	142	16	85	10

Table 12: Torque Values for Stainless Steel Fasteners Larger Than 5/16-inch

Dimension	316 Stainless		18-8 Stainless		18-8 Stainless with Loctite 767	
	Pound-feet	N-m	Pound-feet	N-m	Pound-feet	N-m
3/8 x 16	21	28	20	27	12	16
3/8 x 24	23	31	22	29	13	18
7/16 x 14	33	44	31	42	19	25
7/16 x 20	35	47	33	45	20	27
1/2 x 13	45	61	43	58	26	35
1/2 x 20	47	64	45	61	27	37
9/16 x 12	59	81	57	77	34	46
9/16 x 18	66	89	63	85	38	51
5/8 x 11	97	131	93	125	56	75
5/8 x 18	108	150	104	141	62	84
3/4 x 10	132	179	128	173	77	104
3/4 x 16	130	176	124	168	75	101
7/8 x 9	203	275	194	263	116	158
7/8 x 14	202	273	193	262	116	157
1 x 8	300	406	287	389	172	233
1 x 14	271	367	259	351	156	211
1-1/8 x 7	432	586	413	560	248	336
1-1/8 x 12	408	553	390	529	234	317
1-1/4 x 7	546	740	523	709	314	425
1-1/4 x 12	504	683	480	651	288	390
1-1/2 x 6	930	1261	888	1204	533	722
1-1/2 x 12	732	992	703	953	422	572

2. Preparation



WARNING 2: Fire Hazard—Some solvents and primers are flammable.

- Use threadlocker and primers with sufficient airflow.
 - Do not use flammable material near ignition sources.
1. Clean all threads with a wire brush or a different tool.
 2. Remove the grease from the fasteners and the mating threads with solvent. Make the parts dry.

Note 3: Loctite 7649 Primer™ or standard solvents will remove grease from parts.
 3. Apply a spray of Loctite 7649 Primer™ or equal on the fasteners and the mating threads. Let the primer dry for one minute minimum.

3. How to Apply a Threadlocker

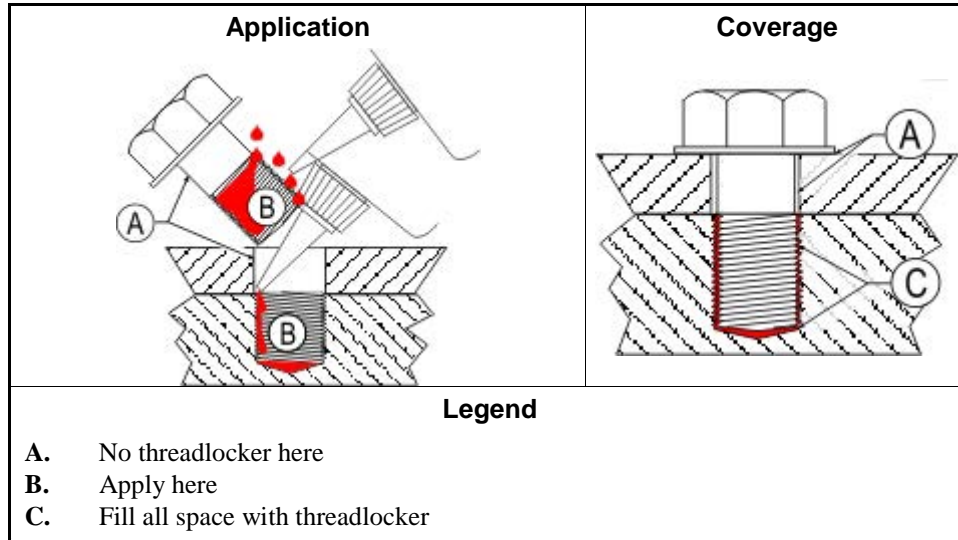


CAUTION 3: Malfunction Hazard—Heat, vibration, or mechanical shocks can let the fasteners loosen if you do not apply the threadlocker correctly. Loose fasteners can cause malfunctions of the equipment.

- Read the threadlocker manufacturer's instructions and warnings. Obey these instructions.

Apply the threadlocker only to the areas where the fastener threads and the mating threads engage.

Figure 2: Blind Hole



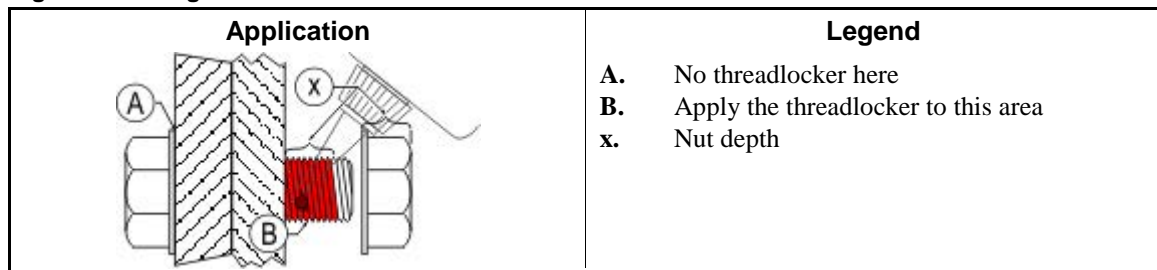
3.1. Blind Holes

1. Apply the threadlocker down the threads to the bottom of the hole.
2. Apply the threadlocker to the bolt.
3. Tighten the bolt to the value shown in the correct table ([Table 5](#) to [Table 11](#)).

3.2. Through Holes

1. Put the bolt through the assembly.
2. Apply the threadlocker only to the bolt thread area that will engage the nut.
3. Tighten the bolt to the value shown in the correct table ([Table 5](#) to [Table 11](#)).

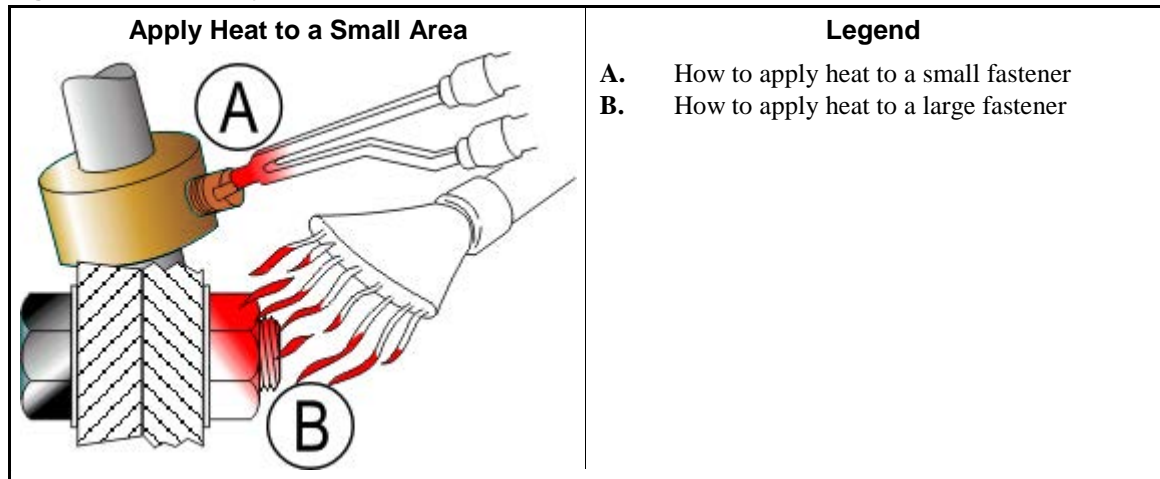
Figure 3: Through Hole



3.3. Disassembly—For high-strength threadlocker, apply heat for five minutes. Disassemble with hand tools while the parts are hot.

For low-strength and moderate-strength threadlocker, disassemble with hand tools.

Figure 4: Disassembly



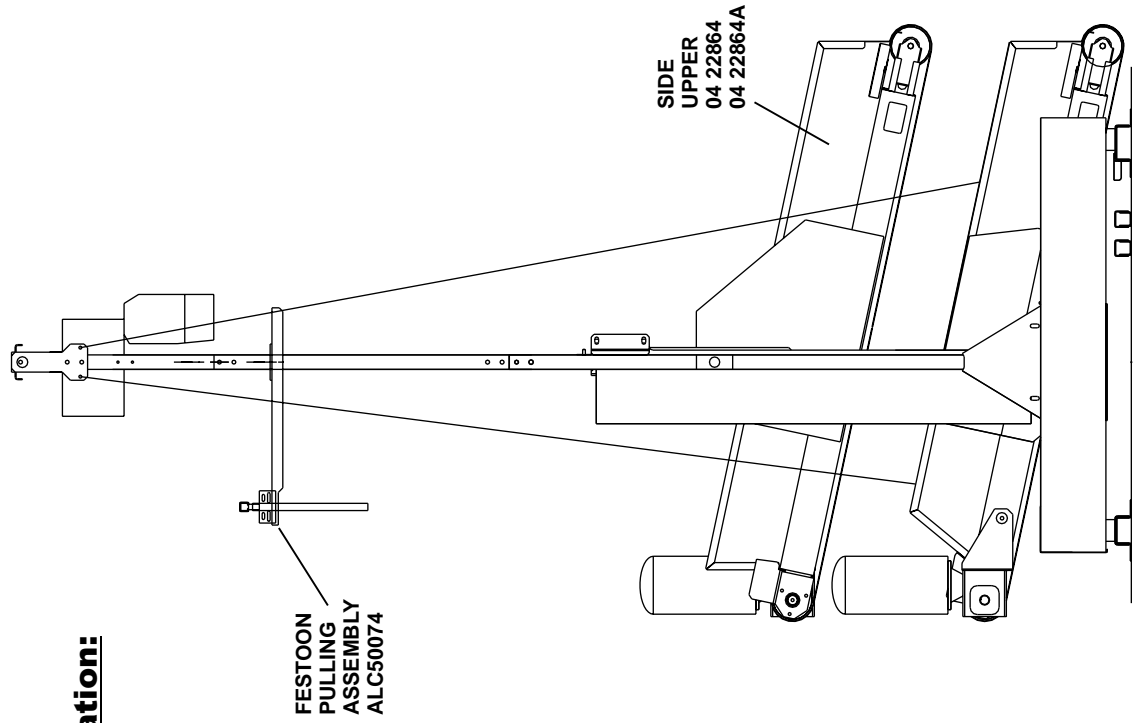
— End of BIUUM04 —



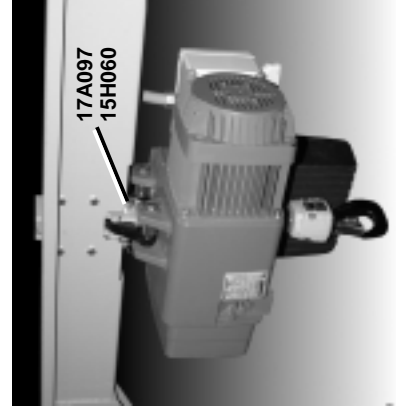
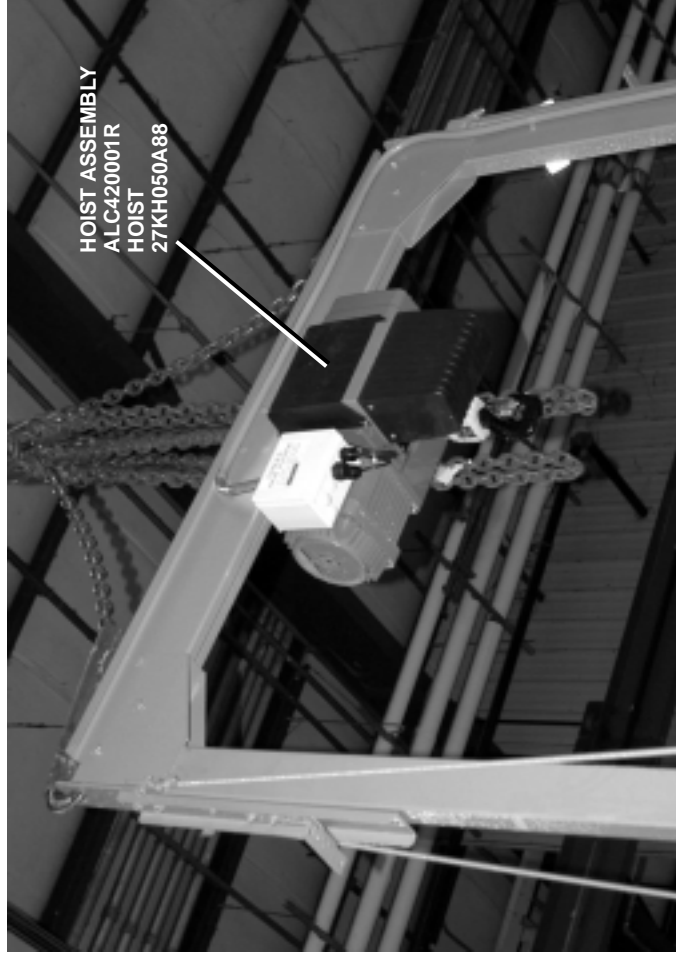
Pellerin Milnor Corporation
P. O. Box 400, Kenner, LA 70063-0400

Parts

Identification:

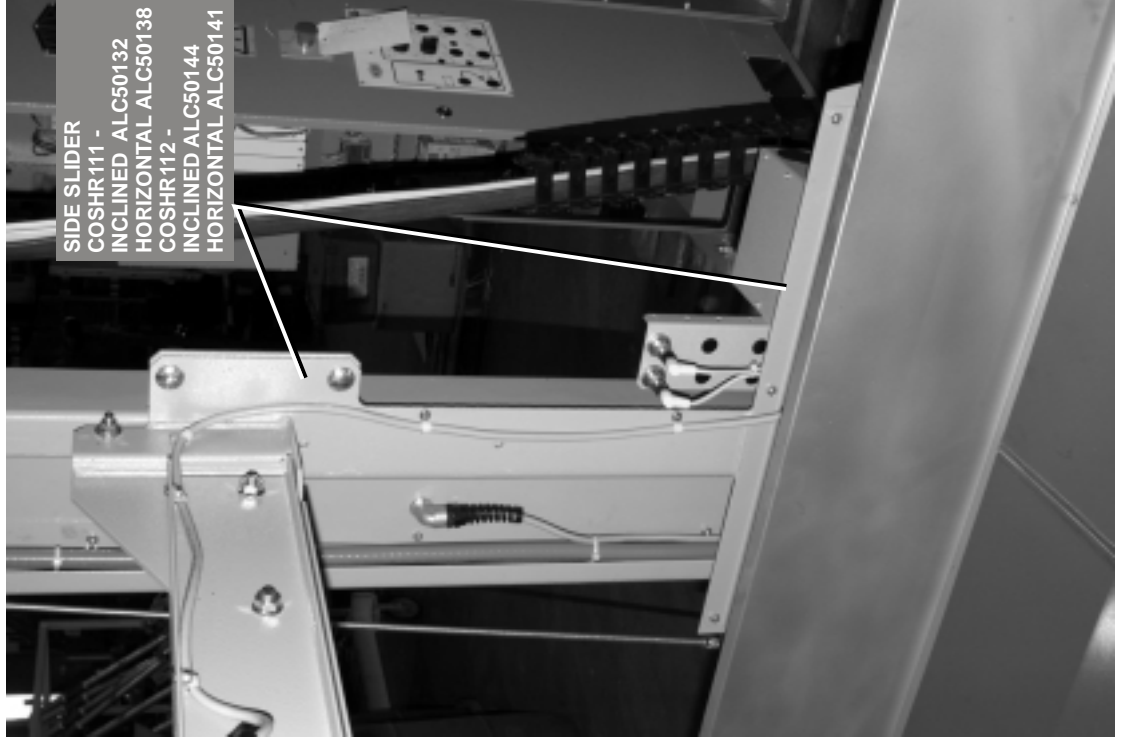
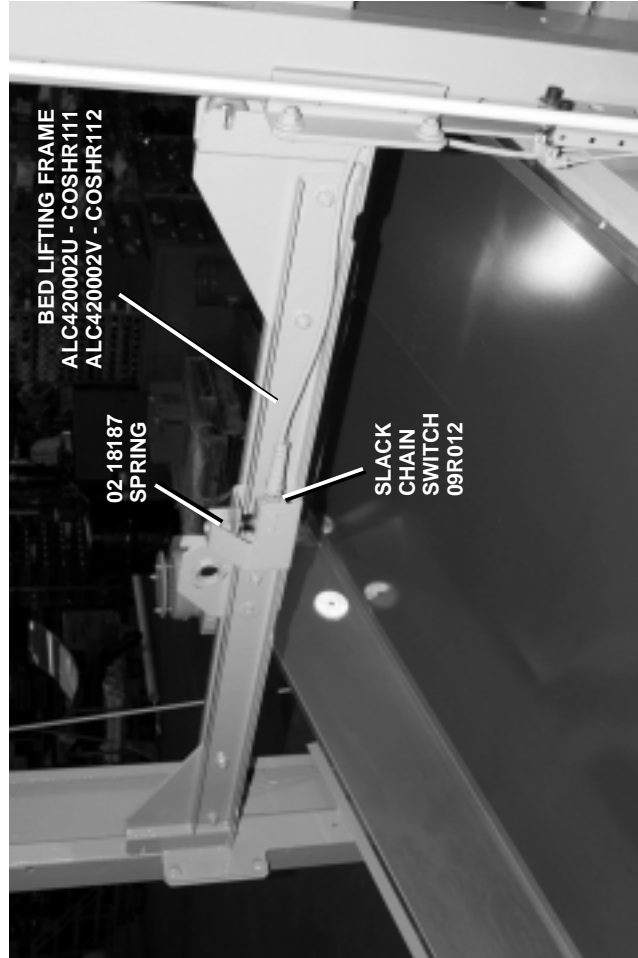


COSHR111, COSHR112



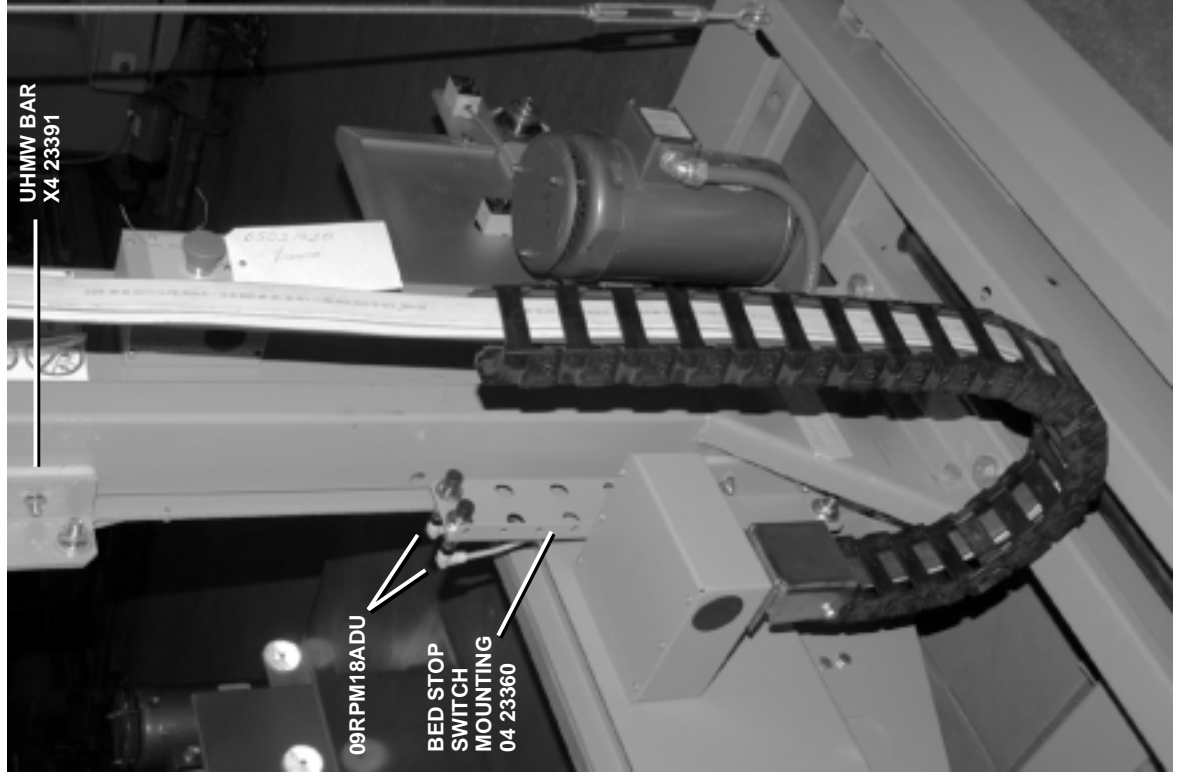
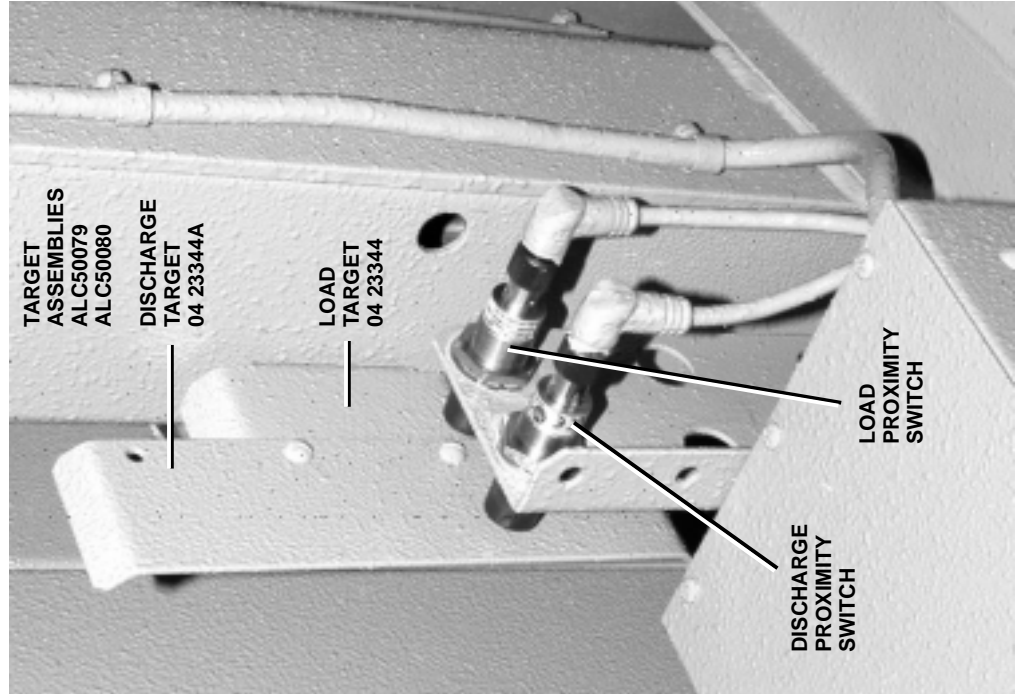


Parts
Identification:



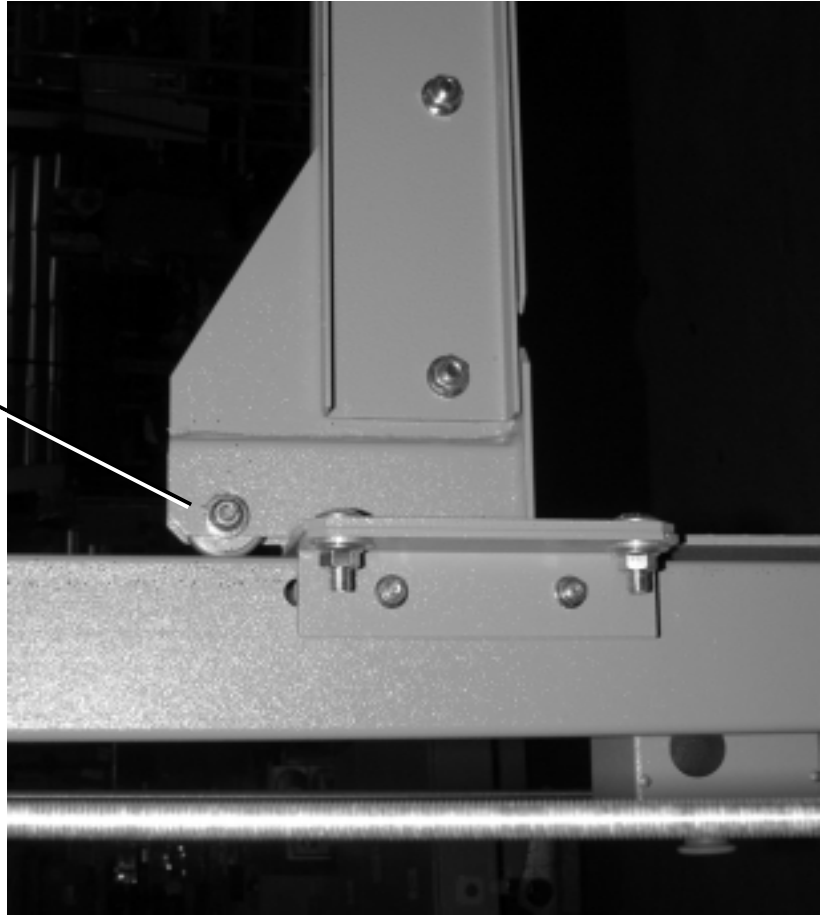


Parts
Identification:



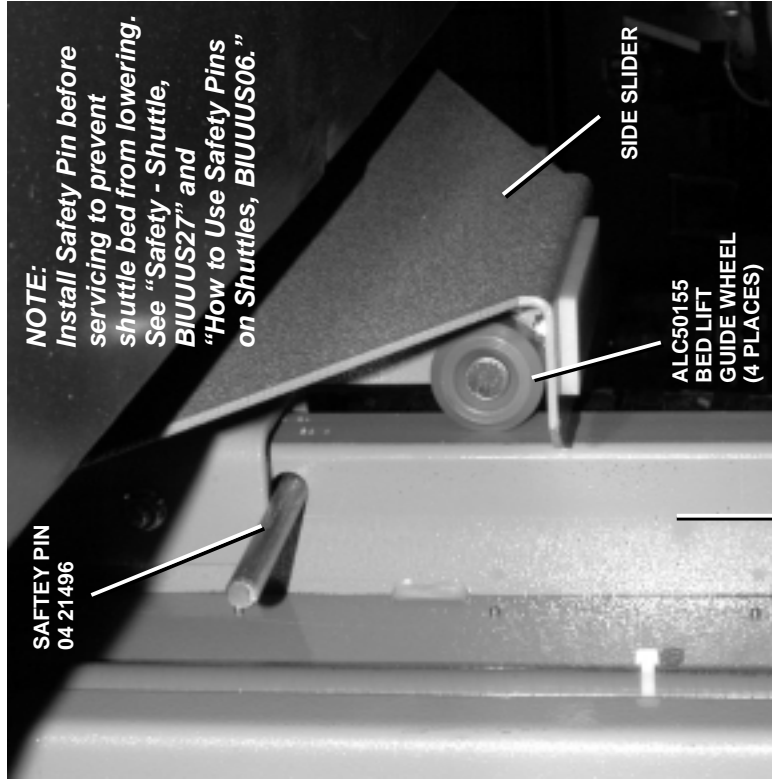
Parts
Identification:

BED LIFT GUIDE WHEEL
ALC50155
(4 PLACES)

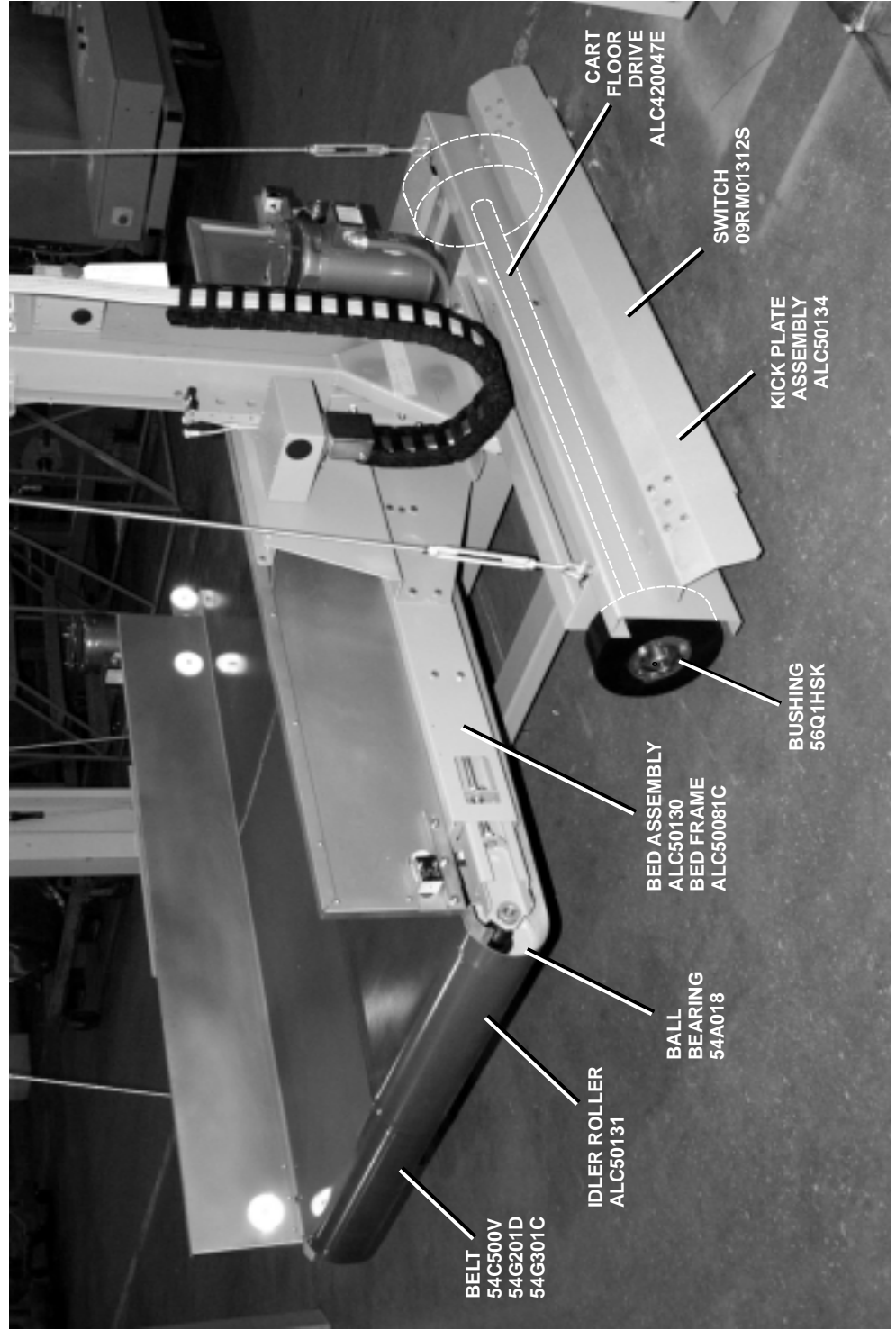


NOTE:
Install Safety Pin before servicing to prevent shuttle bed from lowering. See "Safety - Shuttle, BIUUUS27" and "How to Use Safety Pins on Shuttles, BIUUUS06."

SAFETY PIN
04 21496



Parts
Identification:





Parts Identification:

SIDES FOR HORIZONTAL BED
04 20728
04 20728A

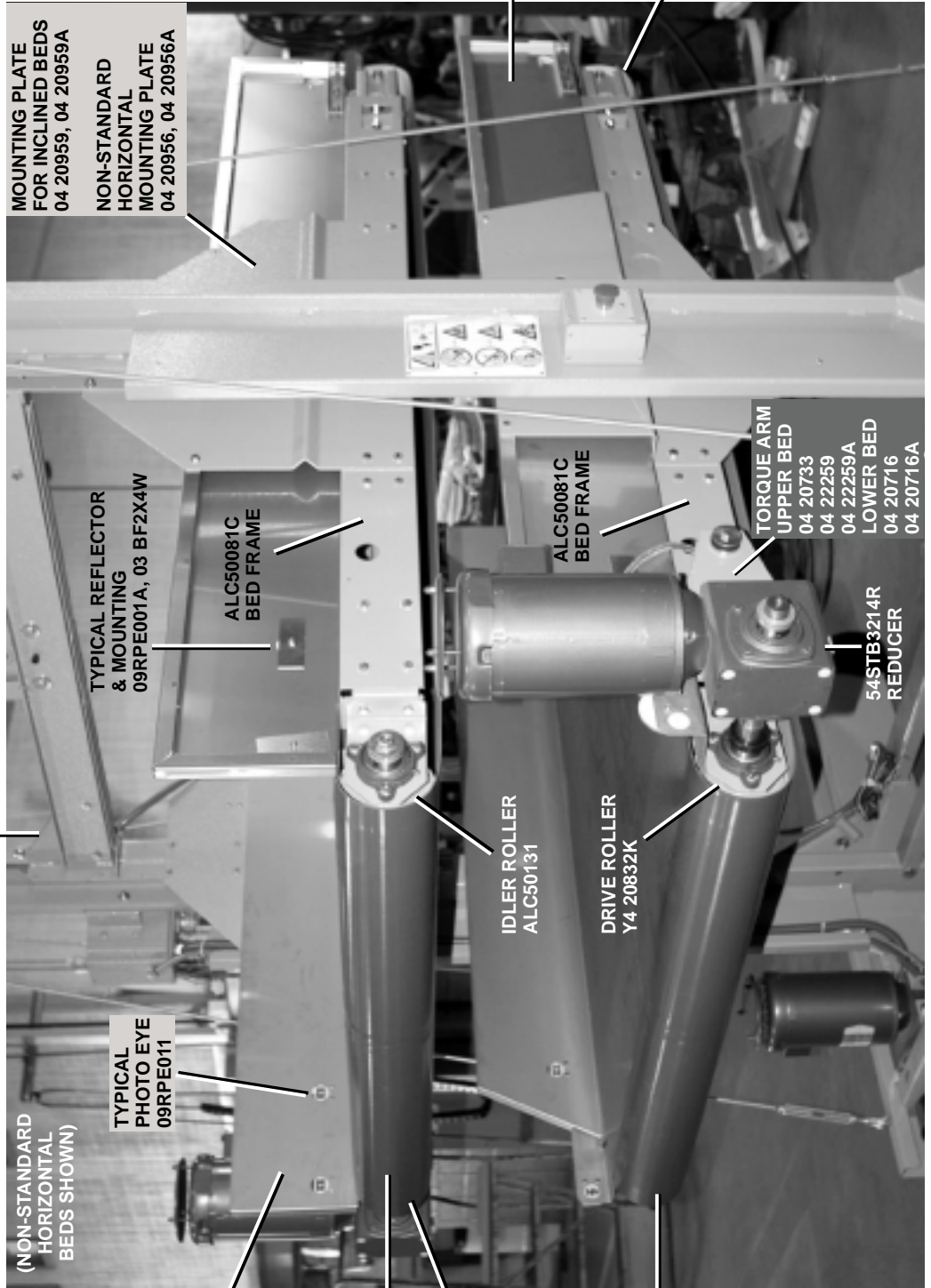
SIDES FOR INLINED BED
04 22864
04 22864A

UPPER BED INCLINED-
ALC50145
HORIZONTAL-
ALC50137

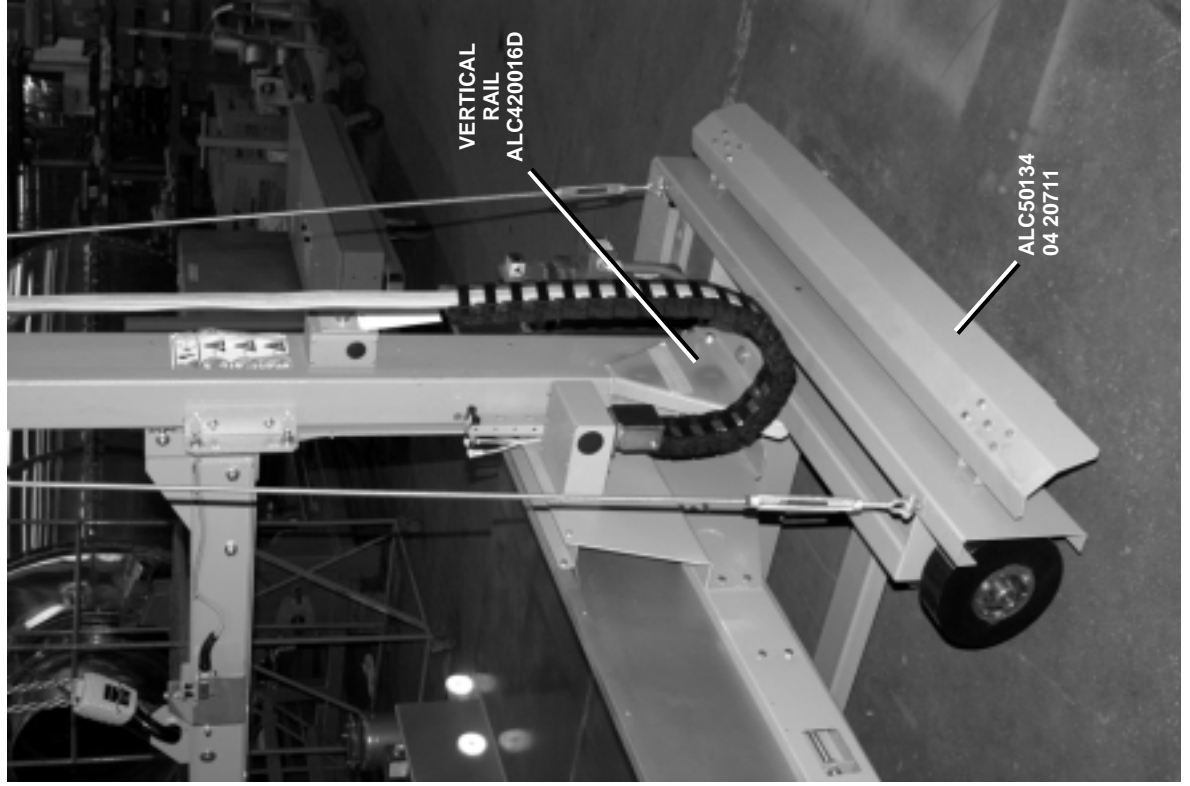
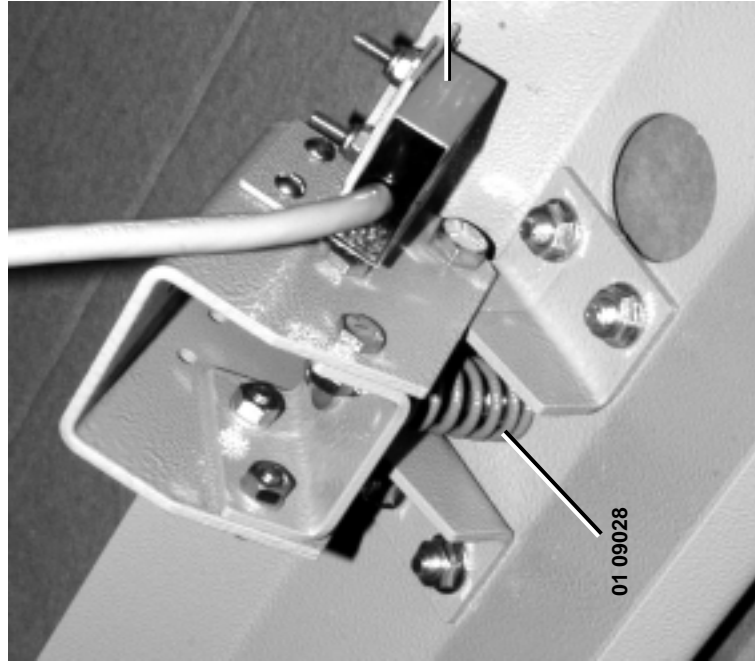
TYPICAL BELT
54C500V
54G201D
54G301C

LOWER BED (INCLINED)
COSHR112-
ALC50146
COSHR111-
ALC50130

LOWER BED (HORIZONTAL)
COSHR111-
ALC50137
COSHR112-
ALC50139
ALC50140

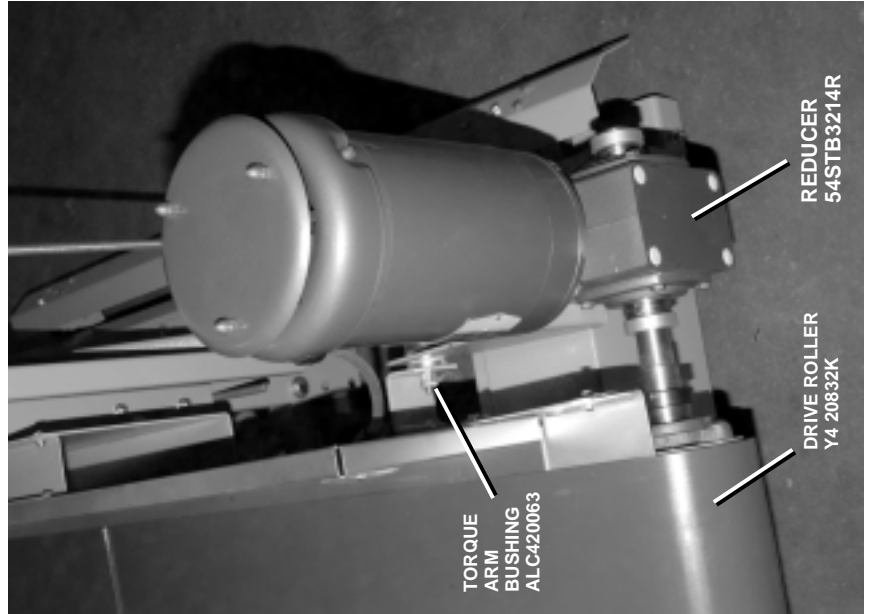


Parts
Identification:

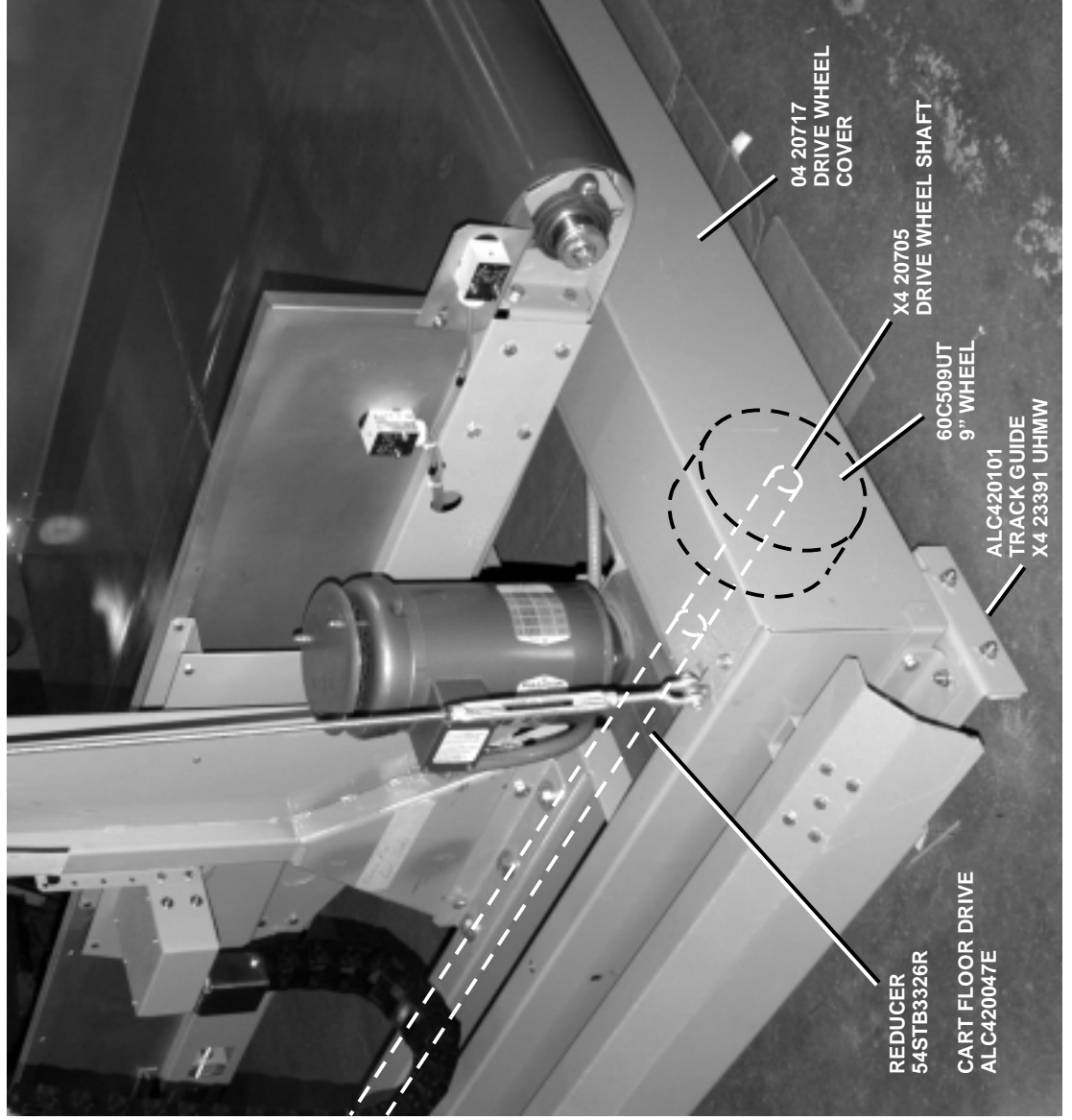


Parts
Identification:

BELT DRIVE



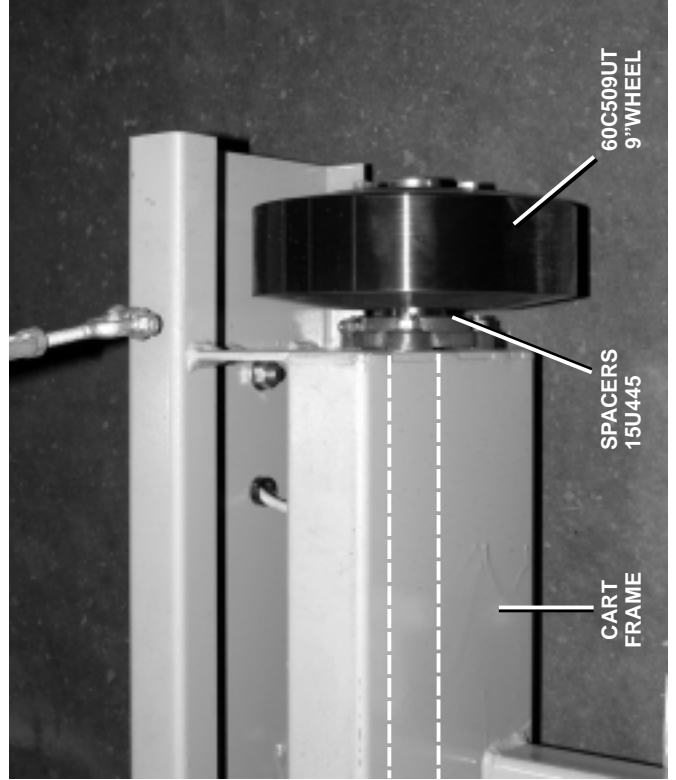
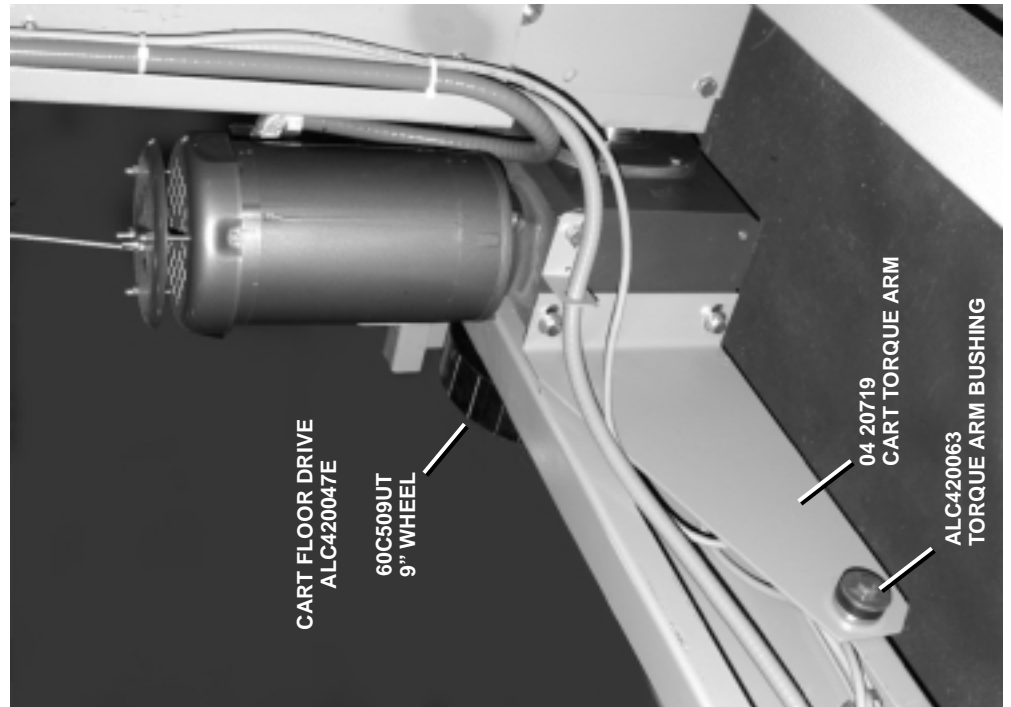
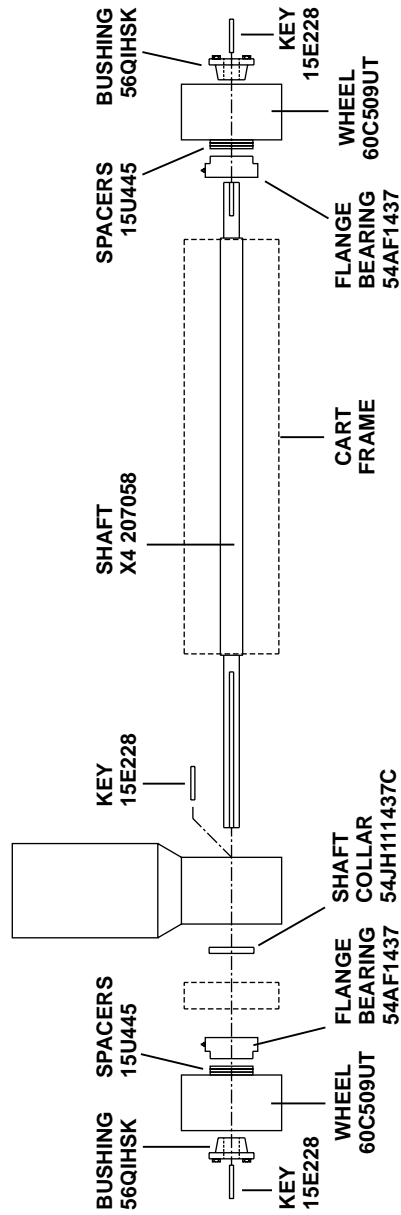
CART DRIVE



Parts

Identification:

CART DRIVE WHEELS

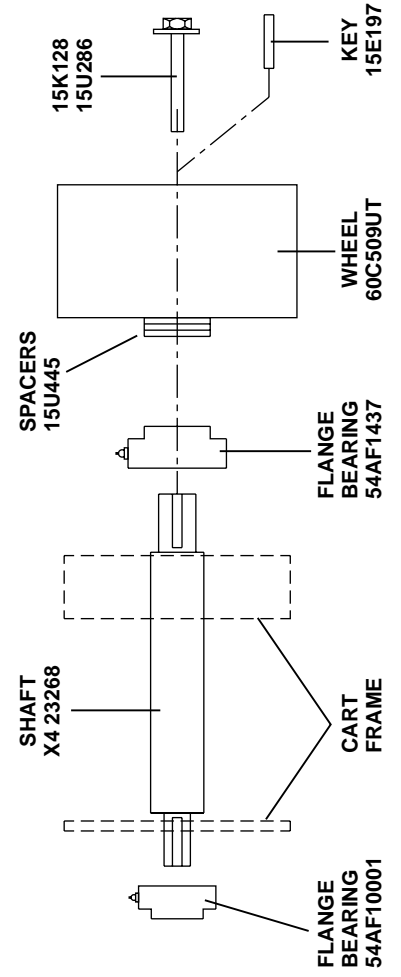
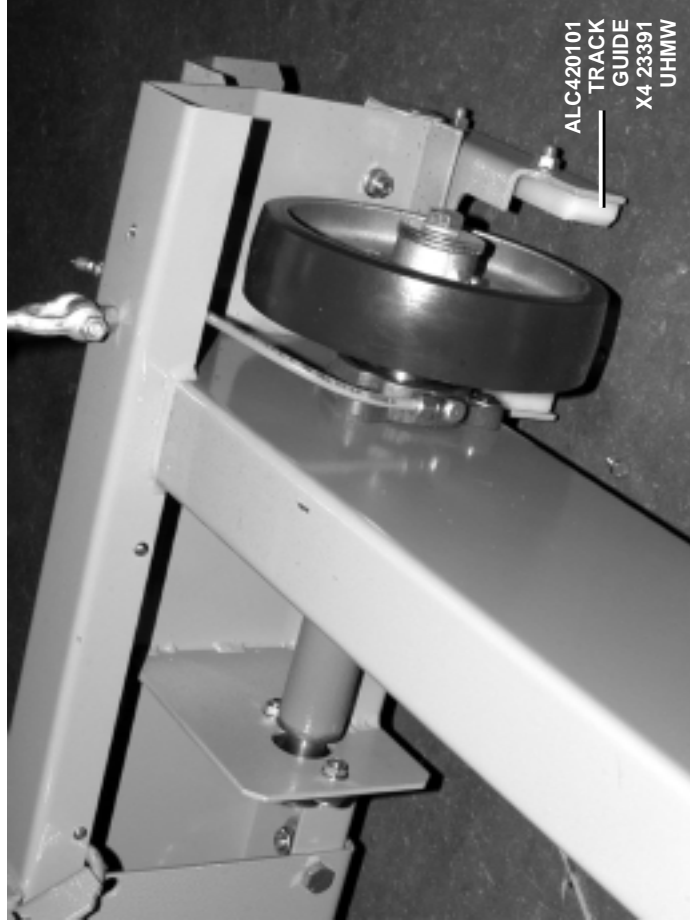




Parts

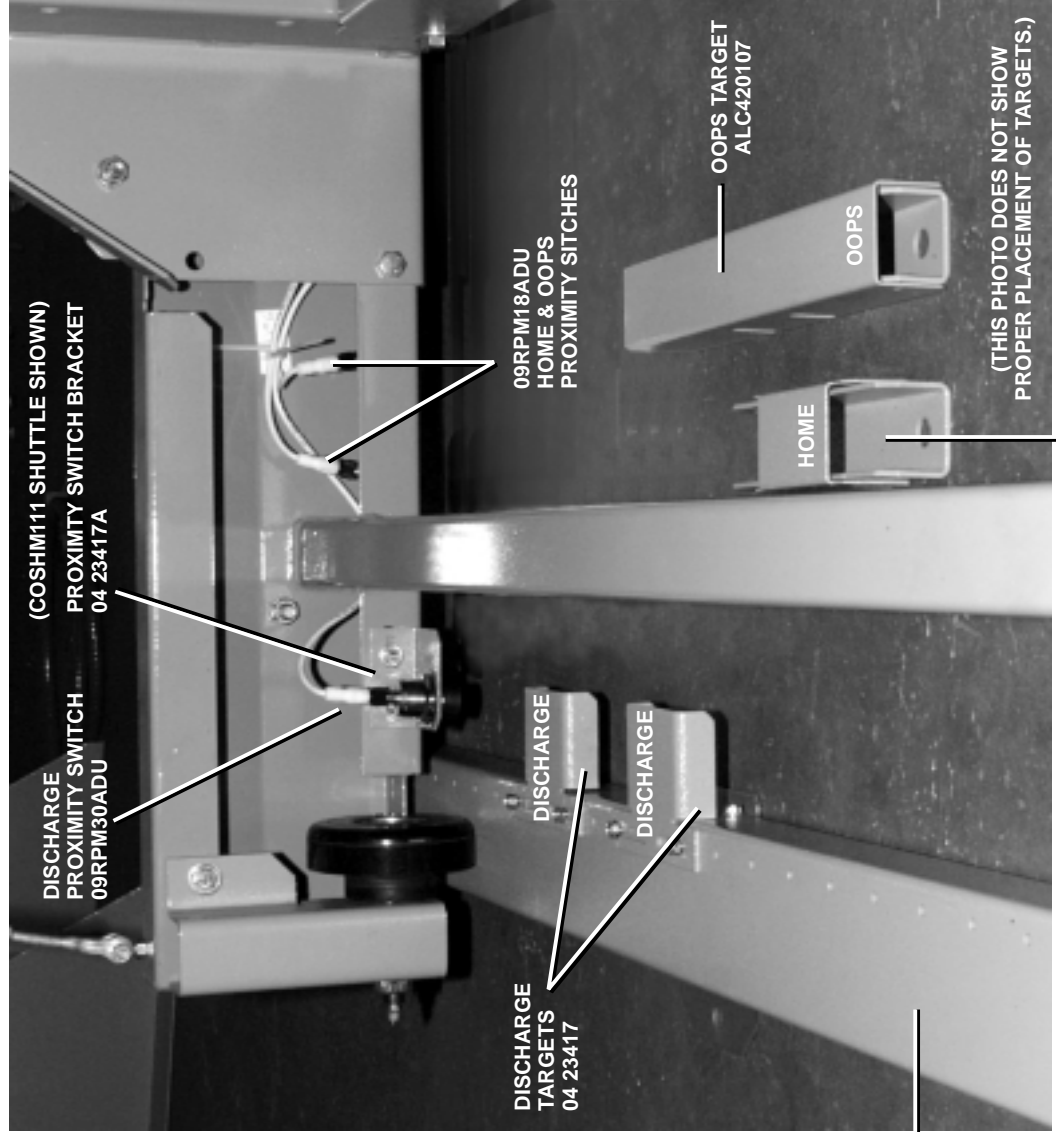
Identification:

CART IDLER WHEELS





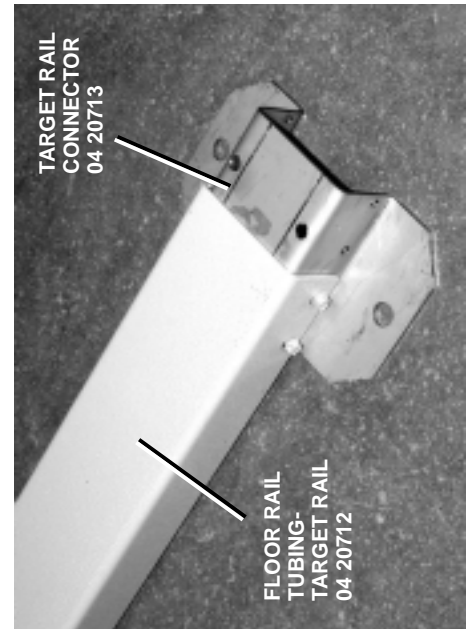
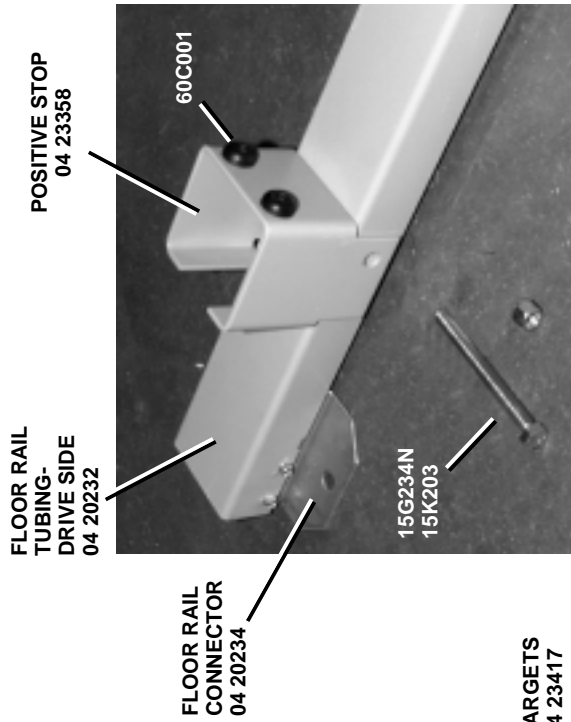
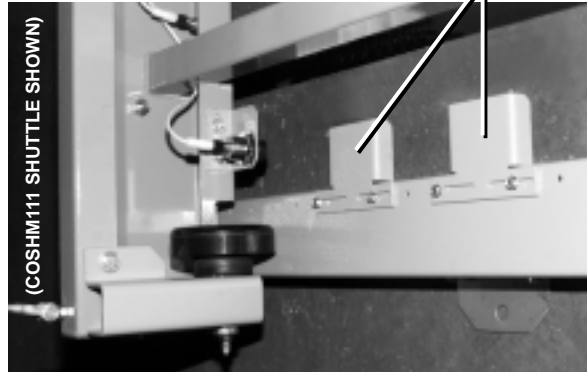
Rail Component
Identification:



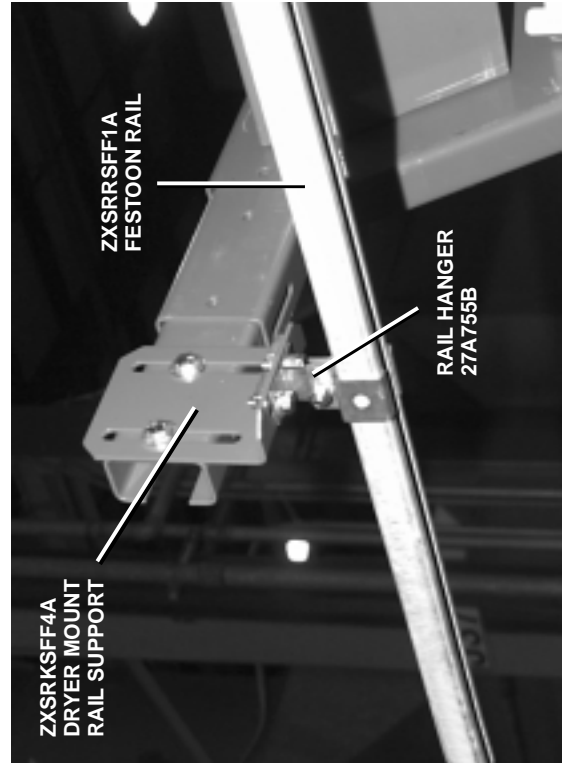
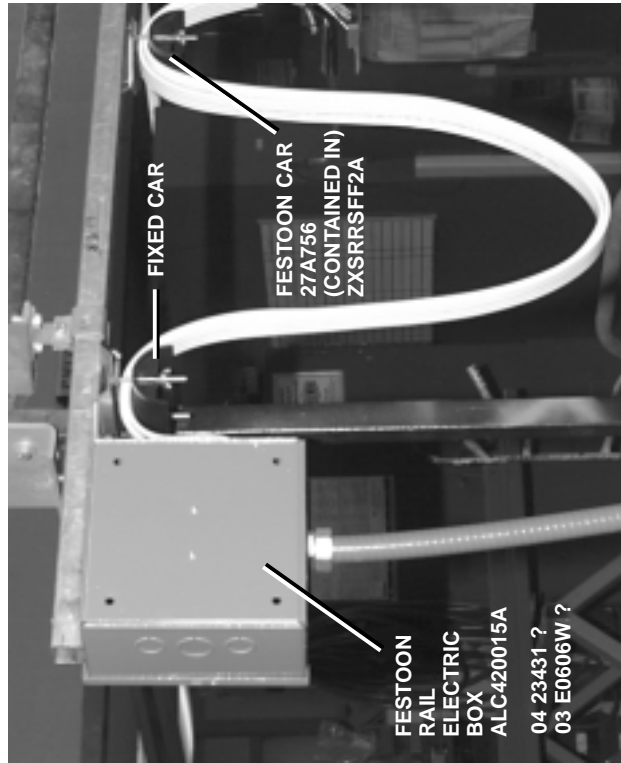
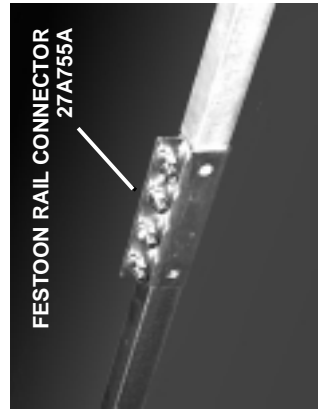
TARGET RAIL
04 20233

HOME TARGET
ALC420106

Rail Component Identification:



ZXSRRMSFE2A
ADDITIONAL FLOOR RAIL
CONSISTS OF:
1 FLOOR RAIL,
1 TARGET RAIL,
3 FLOOR RAIL CONNECTORS
3 TARGET RAIL CONNECTORS

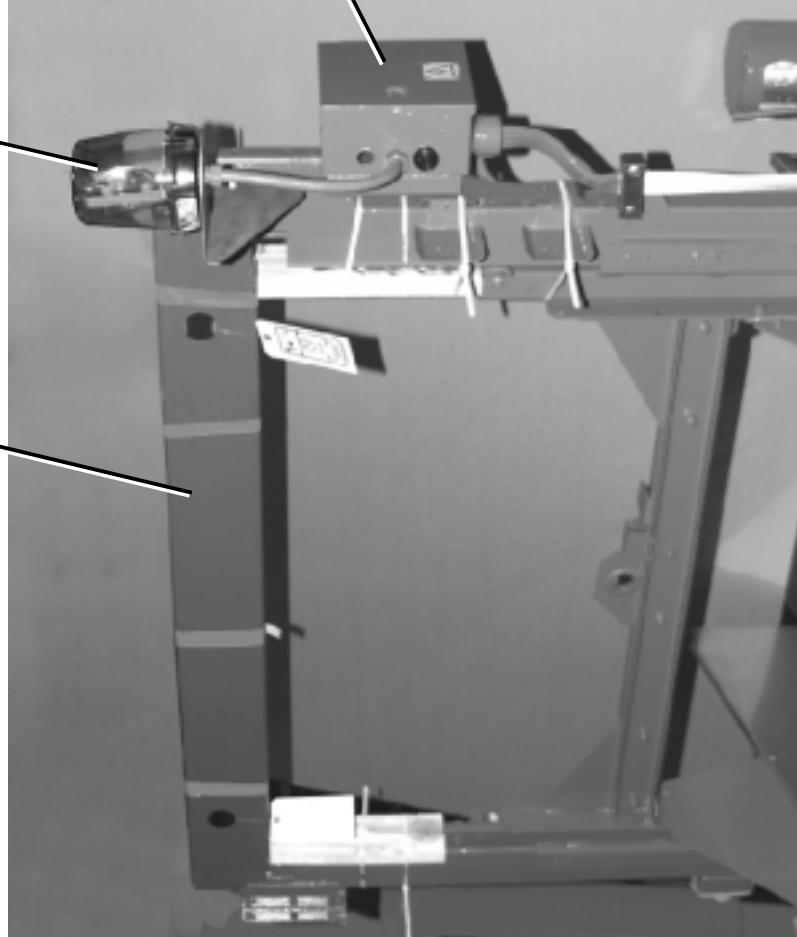


Parts

Identification:

LIFTING BAR FOR SHIPPING
04 20714

BEACON
09H025V37



FESTOON CABLE
JUNCTION BOX

Parts List

COSHR 111/112



Pellerin Milnor Corporation
P. O. Box 400, Kenner, LA 70063-0400

Litho in U.S.A.

MLQCOSHRAE/2007103B
(Sheet 1 of 7)

Parts List
Find the correct assembly first, then find the needed components. The item letters (A, B, C, etc.) assigned to assemblies are referred to in the "Used In" column to identify which components belong to an assembly. The item numbers (1, 2, 3, etc.) assigned to components relate the parts list to the illustration.

Assembly	Item	Part Number	Description
	04 20232	2005333	FLOOR RAIL-DRIVE SIDE=10FT
	04 20234	2005153	FLOOR RAIL CONNECTOR-COSHMP/Q
	04 20712	2005333	TARGET RAIL 2-DRV CART=10FT
	04 20713	2005153	TARGET RAIL CONNECTOR-COSHR
	04 20714	2004455	LIFTING BAR COSHR-SHIPPIG
	04 20719	2005032	TORQARM COSHR CARTDRV-732
	04 23417	2005044	SHUTL DISCHARGE TARGET
	09H025V37	2002204	BEACON ROTARY 5.5"DIA AMBER
	09RM01312S	CAPSW 12FT 90DEG ROLLER SILVER	
	09RPM18ADU	2001306	PRXSW QD CONN 18M NO-DC UNSHLD
	09R012	MICSW SPDT PAINTED BZE6-RN 01	
	27A755A	PARA-TRACK JOINT CLMP:#FC-CH1D	
	27A755B	PARA-TRACK HANGER ASSY.	
	27KH050A88	DEMAGHOIST 1 TON 24FT/MIN 460V	
	54C500V	BELT 51" GREY WDGGRIP W/VGUIDE	
	54G201D	CLIPLACE#UX-1-36S E=1PC 3FT LG	
	54G301C	BLTLACERCONN #13NYL-SS EA=1FT	
	54STB3214R	91136 REDCR40 B#SF721-40T-B5-G +OIL	
	54STB3326R	91136 REDCR60 B#SF732-60T-B7-G +OIL	
	60C001	RUBBER BUMPER-BLKW/WASHER #698	
	60C509UT	WHEEL SINGLE 9"OD URETHANE	
ALC420001R	2004413	HOIST ASSEMBLY-COSHR	
	10	W4-23338	2006425C TOP BEAM SUPPORT WLMT
	20	04-20710	2006106D TOP BEAM-COSHR
	30	04-21372	2005212B HOIST MTG BRKT-DCPRO
	31	04-21373	2005515B HOIST HANGER PLATE-DCPRO
	32	17A097	CLEVIS PIN 1"X2+3/4"DRILLED Z
	33	15H060	STDCOTTERPIN 3/16X2 ZINCPL
	34	04-20168	2006413B HOIST HANGER SHIM
	40	04-23310	2002242B TOP BEAM CONNECTING STRAP
	60	15K095	HXCPSCR 3/8-16UNC2AX1 GR5 ZIN
	70	15U255	LOCKWASHER MEDIUM 3/8 ZINCPL
	80	15G205	HXNUT 3/8-16UNC2B ZINC GR2
	90	15K151	HXCAPSCR 1/2-13UNC24X1.25 GR5
	110	15U280	01Z FL+WASHER(USS STD)1/2 ZNC PL+
	120	15U300	LOKWASHER REGULAR 1/2 ZINC PL
	130	15G230	HXNUT 1/2-13UNC2B SAE ZINC GR
	140	17N080	1/2-13 GRIPNUT ZINC #C7968-12
ALC420002U	2004413	BED LIFTING FRAME-COSHR111	
	10	ALC50132	2004413N LF/RT SIDE SLIDER-COSHR111
	20	04-20708	2004474C BED LIFTING CHANNEL-COSHR
	30	W4-23347	2006035C BED LIFT PLATE WLMT
	50	15K151	HXCAPSCR 1/2-13UNC24X1.25 GR5

Assembly	Item	Part Number	Description	Comments
	60	15U300	LOKWASHER REGULAR 1/2 ZINC PL	
	70	15G230	HXNUT 1/2-13UNC2B SAE ZINC GR	
	210	04-20709	2004474C BED LIFTING CHAN SPACER-COSHR	
	220	04-20721	2005093C SLACHCHAIN SPRING COVER-COSHR	
	230	02-18187	2006434B SPRING=OUTER DOOR 60 WEHU	
	231	15N141	RDMACSCR 10-24NCX3/4 SLOTTED	
	232	15G126	01Z HXLOCKNUT NYLON 10-24 UNC SS	
	240	15K111	2003316A SKCPS3/8-16 UNC3 X 1.5 BLK	
	250	15G207	HEXLIGHTLOK NUT 3/8-16 18-8SS	
	260	15U285	01Z FLATWASHER 1/2 STD COMM SS18-	
	280	17A040	CLEVIS PIN 1/2"X1+3/8" DRILLE	
	290	15H040	STDCOTTERPIN 1/8X3/4 ZINCPL	
ALC420002V	2005186	BED LIFTING FRAME-COSHR112		
	10	ALC50144	2005186N LF/RT SIDE SLIDER-COSHR112	
	20	ALC50142	UPPER SLIDING PAD ASSY-COSHR	
	30	04-20708	2004474C BED LIFTING CHANNEL-COSHR	
	40	04-20709	2004474C BED LIFTING CHAN SPACER-COSHR	
	50	W4-23347	2006035C BED LIFT PLATE WLMT	
	60	15K151	HXCAPSCR 1/2-13UNC24X1.25 GR5	
	70	15U300	LOKWASHER REGULAR 1/2 ZINC PL	
	80	15G230	HXNUT 1/2-13UNC2B SAE ZINC GR	
	90	15K111	2003316A SKCPS3/8-16 UNC3 X 1.5 BLK	
	100	15G207	HEXLIGHTLOK NUT 3/8-16 18-8SS	
	110	17A040	CLEVIS PIN 1/2"X1+3/8" DRILLE	
	120	15H040	STDCOTTERPIN 1/8X3/4 ZINCPL	
	130	15U280	01Z FL+WASHER(USS STD)1/2 ZNC PL+	
	140	04-20721	2005093C SLACHCHAIN SPRING COVER-COSHR	
	150	02-18187	2006434B SPRING=OUTER DOOR 60 WEHU	
	160	15N141	RDMACSCR 10-24NCX3/4 SLOTTED	
	170	15G126	01Z HXLOCKNUT NYLON 10-24 UNC SS	
ALC420015A	98251	FESTOON RAIL ELEC BOX ASSY		
	1	04-22847A	94296B FESTOON STATIONARY MTG BKT	
	2	04-22847B	2004425B FIXED FESTOON MTG FLATBAR	
	3	03-E8X8X4	2005054D ENCL=JUNCTION BOX SHUTTLE	
	7	15A009	CARBOLT 5/16-18NC2X3.5 FULTHD	
	8	15U210	LOKWASHER MEDIUM 5/16 ZINCPL	
	9	15G193	HEXLOKNUT 5/16-18UNC2A NYL ST	
	10	15K039	HXCAPSCR 1/4-20UNC2AX3/4 GR5	
	11	15U180	LOCKWASHER MEDIUM 1/4 ZINCPL	
	12	15G165	HXNUT 1/4-20UNC2BSAE ZC GR2	
	13	03-C8X8X1	99316C COVER PLATE	
	14	09B002GYD	IEC TERM BLOCK 600V #26-10GRN	
	15	09B002END	IEC TERM BLOCK END STOP	
	16	09B102	MKRSTP FIB.4STA 300V #X20504B	
	17	09BB004SWQ	01Z TERMSTRIP 4-STA. SCREWED 600V	
	18	09B102	MKRSTP FIB.4STA 300V #X20504B	
	19	09VFF0814C	CONN.14/8 CABL DOW #FC-816C2	

Parts List
COSHR 111/112



Pellerin Milnor Corporation
P. O. Box 400, Kenner, LA 70063-0400

Litho in U.S.A.

MLQCOSHRAE/2007103B
(Sheet 2 of 7)

Find the correct assembly first, then find the needed components. The item letters (A, B, C, etc.) assigned to assemblies are referred to in the "Used In" column to identify which components belong to an assembly. The item numbers (1, 2, 3, etc.) assigned to components relate the parts list to the illustration.

Parts List		Parts List, cont.		
Assembly	Item	Part Number	Description	Comments
	195	09VFF0814E	CONN. 14/8 CABLE DOW#FC816C4	
	200	09B002GA8	IEC TERM BLOCK 600V 22-6# GRA	
	210	12P40MARK	2006042A IEC MARKER AVB #1492-MS5X9	
	220	09B002INSE	IEC TERM BLOCK INSULATION END	
	230	01-10375	88441B NPLTE:"WARNING" 2X2	
	240	03-BV108X	2000174B DINRAIL 8 RAIL	
	250	27A756C	SADDLE ASSY.ONLY DOW #FC-S1	
ALC420016D	98000		VERTICAL RAIL ASSY-COSHMP/P	
	10	W4-23313	2003424C VERTTRAIL TUBING WLMT-RT	
	11	W4-23313A	2003424# VERTTRAIL TUBING WLMT-LF	
	20	04-23335	2001134B VERTICAL RAIL MTG ANGLE	
	40	04-23386	2005124C FESTOON ELEC BOX BRKT	
	50	04-23310	2002242B TOP BEAM CONNECTING STRAP	
	60	04-20198	2006466B NUT STRIP 1/2"-13UN-SIDERAIL	
	200	X4-23342	2005223B TUBE CONNECTING BAR	
	210	04-23331	2005223B VERT TUBE ALIGN BAR	
	211	15K190A	HEXTAPSCR 1/2-13X2.5 ZINC GR5	
	212	15G230	HXNUT 1/2-13UNC2B SAE ZINC GR	
	220	15K180	HXCAPSCR 1/2-13UNCAX2 GR5 ZIN	
	240	15U280	01Z FL+WASHER(USS STD)1/2 ZNC PL+	
	250	15U300	LOKWASHER REGULAR 1/2 ZINC PL	
	280	04-23345	2002224B FESTOON J-BOX MTG BRKT	
	300	15K085	HXCAPSCR 3/8-16UNC2AX3/4 GR5	
	310	15U255	LOKWASHER MEDIUM 3/8 ZINCPL	
	320	15G205	HXNUT 3/8-16UNC2B ZINC GR2	
	330	04-21496	88023C SAFETY PIN-COSHA	
	340	03-E0406	2002034B ENCL:M6 DRY PROX SW FULL OPN	
	350	03-E0406V	2003456B COVER:COSHMP JUNCTION BOX	
	360	ESP61EMS	85527N * SWPNL= M6PRS EMERGENCY STOP	
ALC420047E	2004413		CART FLOORDRIVE-COSHR	
	10	W4-20700	2005152D CARTDR FRAME WLMT-COSHR	
	20	ALC420101	98000Z TRACK GUIDE ASSY-COSHMP	
	30	54AF1437	FLANGEBRG.HUBCITY FB150X1+7/1	
	40	54STB3326R	91136N REDCR60 B#SF732-60T-B7-G +OIL	
	45	54JH11437C	SHAFTCOLLAR 1.4375 CFG #23S	
	50	60C509UT	01Z WHEEL SINGLE 9"OD URETHANE	
	60	56Q1HSK	1+7/16" BUSH VPUL QD TYPE SK	
	70	15K081	HXTAPSCR 5/16-18NCX3TFL GR5 Z	
	80	15U210	LOKWASHER MEDIUM 5/16 ZINCPL	
	90	04-20718	2005216B WHEEL COVER BOTTOM CATCH	
	100	04-20717	2004455D DRIVE WHEEL COVER	
	180	15K095	HXCPCSCR 3/8-16UNC2AX1 GR5 ZIN	
	181	17A065	01Z EYE END 1/2-13 X2.25 ZINC	
	182	15U240	FLATWASHER(USS STD) 3/8" ZNC	
	190	15U255	LOKWASHER MEDIUM 3/8 ZINCPL	
	200	15G218	01Z HXLKKNUT NYL 3/8-16 STL/ZNC	
	210	15P200	02Z TRDCUT-F HXWASHD 3/8-16X3/4NI	
	230	15G205	HXNUT 3/8-16UNC2B ZINC GR2 ...	
	240	15P149	1/4-14X3/4 SCRSELFDRIL+TAP ZC	
	250	ALC50135	2004423N IDLER WHEEL/SHAFT-COSHR	
	260	X4-20705	2004423C DRIVE WHEEL/SHAFT-COSHR	
	280	04-20719	2005032B TORQARM COSHR CARTDRV-732	
	290	ALC420063	95452N TORQUE ARM BUSHING ASSEMBLY	
ALC420063			TORQUE ARM BUSHING ASSEMBLY	
	A01	15K144C	HEXCAPSCR 7/16-14UNC X 2.5 GR	
	A02	15G222	HXFINJAMNUT 7/16-14UNC2B ZINC	
	A03	15G222C	HEXNUT 7/16-14UNC2B ZINC GR2	
	A04	15U271	LOKWASH INTOOTH 7/16ZN	
	A05	15U312	2005095A HARD FWASH 3/4ODX33/64IDX.115	
	A06	15U202	FLATWSHR 50ID1.75OD11GA ZNC	
	P01	60B065	RUBBER MNT CTR BONDED 40 DURO	
	P02	04-20796	85372B SLEEVE=TORQUE ARM BUSHING	
	P03	02-18571A	2001225A PISTON ROD WASHER-.25"TK	
ALC420101			TRACK GUIDE ASSY-COSHMP	
	10	04-20235	2006496C TRACK GUIDE CHANNEL-CARTDRIVE	
	11	04-20236	2001514B TRACK GUIDE MTG BRKT	
	20	X4-23391	98431B TRACK SLIDER UHMW BAR	
	40	27B25002SZ	SPCRROLL.39ID.125L.048T STLZN	
	50	15K110	HEXCAPSCR 3/8-16UNC2AX1.5 GR5	
	60	15U200	FLATWASHER(USS STD) 5/16"ZNC	
	70	15U266	FLATWASHER 1"0DX7/16"IDX3/16"	
	80	15U255	LOKWASHER MEDIUM 3/8 ZINCPL	
	90	15G218	01Z HXLKKNUT NYL 3/8-16 STL/ZNC	
	100	15A011	CARBOLT 3/8-16UNC2X1 ZINC GR2	
	110	15K095	HXCPCSCR 3/8-16UNC2AX1 GR5 ZIN	
ALC420106			HOME TARGET FLOOR MTG ASSY	
	10	04-23416	2006186B FLOOR MTG TARGET-BASE	
	20	04-23416A	2005044B HOME TARGET-COSHMP	
	30	15A011	CARBOLT 3/8-16UNC2X1 ZINC GR2	
	40	15U240	FLATWASHER(USS STD) 3/8" ZNC	
	50	15G205	HXNUT 3/8-16UNC2B ZINC GR2	
ALC420107	99273		OOPS TARGET FLOOR MTG ASSY	
	10	04-23416	2006186B FLOOR MTG TARGET-BASE	
	20	04-23416A	2005044B HOME TARGET-COSHMP	
	30	15A011	CARBOLT 3/8-16UNC2X1 ZINC GR2	

Parts List
COSHR 111/112



Pellerin Milnor Corporation
P. O. Box 400, Kenner, LA 70063-0400

Litho in U.S.A.

MLQCOSHRAE/2007103B
(Sheet 3 of 7)

Parts List
Find the correct assembly first, then find the needed components. The item letters (A, B, C, etc.) assigned to assemblies are referred to in the "Used In" column to identify which components belong to an assembly. The item numbers (1, 2, 3, etc.) assigned to components relate the parts list to the illustration.

Assembly	Item	Part Number	Description
ALC50074	40	15U240	FLATWASHER(USS STD) 3/8" ZNC
	50	15G205	HXNUT 3/8-16UNC2B ZINC GR2
	FESTOON PULLING ASSEMBLY		
	10	04-22409	99267C SHUTL FESTOON MTG BRKT
	20	04-22410	2005226B FESTOON PULL CHANNEL
	30	15K069	HXCAPSCR 5/16-18UNC2AX1.25 GR
	50	15U200	FLATWASHER(USS STD) 5/16"ZNC
	51	15U210	LOKWASHER MEDIUM 5/16 ZINCPL
	60	15G185	HXNUT 5/16-18UNC2B SAE ZINC G
	70	04-20750	85381B PAD=FESTOON CABLE CLAMP
	90	04-20750B	85243B CHANNEL=PAD CLAMP FESTOON
	100	15A009	CARBOLT 5/16-18NC2X3.5 FULTHD
	110	15G193	HEXLOKNUT 5/16-18UNC2A NYL ST
	120	04-22317	2006142B FESTOON ARM MTG RAIL
	130	15A010	67346A CARRSCR 3/8-16UNC2X1 SPECIAL
140	15U246	FLATWASHER 1"ODX25/64IDX1/8"3	
150	15G198	HXFLGNUT 3/8-16 ZINC	
ALC50079	2000235	LOAD TARGET ASSY-COSHM	
	10	04-23344	2006125D BED STOP TARGET-LOAD
	20	15K046	HXCAPSCR 1/4-20 UNC2A X 2"GR5
	30	15U180	LOKWASHER MEDIUM 1/4 ZINCPL
	40	15U185	FLATWASHER(USS STD) 1/4" ZNC
	50	17N058	HEXRIVNUT 1/4-20 UNC-2B #2520
	DISCHARGE TARGET ASSY-COSHM		
	10	04-23344	2006125D BED STOP TARGET-LOAD
	20	04-23344A	2005534D BED STOP TARGET-DISC
	30	15K046	HXCAPSCR 1/4-20 UNC2A X 2"GR5
40	15U180	LOKWASHER MEDIUM 1/4 ZINCPL	
50	15U185	FLATWASHER(USS STD) 1/4" ZNC	
60	17N058	HEXRIVNUT 1/4-20 UNC-2B #2520	
70	17M010	01Z #8-32X3/8" FPHMSUC ZINC	
80	15U120	LOKWASHER MEDIUM #8 ZINCPL	
90	15G100	HXMACHSCRNUT 8-32UNC2B ZINC G	
ALC50081C	BED FRAME 50WX84LG ASSEMBLY		
	10	04-22870	2004162D BED HALF 50WX84LG-RT SIDE
	20	04-22870A	2004162# BED HALF 50WX84LG-LF SIDE
	30	W4-22872	2004162C BED 50W X-MEMBER WLMT
	40	04-20809	82533C JOINER PLATE CONV

Parts List, cont.					
Assembly	Item	Part Number	Description	Comments	
ALC50130	50	04-22868	2004162B BRNGCARR 84LG BED LOADEND RT		
	51	04-22868A	2004162B BRNGCARR 84LG BED LOADEND LF		
	60	04-22869	2004162B BRNGCARR 84LG BED-UNLOAD END		
	70	04-22752	2001075B BED CORNER BRKT LOAD END		
	80	04-22748	2002354B LOADEND BRNGCARR CHAN-COSHQ		
	81	04-22749	2000333B LOADEND BRNGCARR SHIM		
	90	04-22761	94061B BRNG CARRIER ADJ BRKT		
	100	15P010	12Z TRDCUT PHILPANHDSR 10-24X1/2		
	110	15K060	HXCAPSCR 5/16-18UNCAX3/4 GR5		
	120	15U200	FLATWASHER(USS STD) 5/16"ZNC		
	130	15U210	LOKWASHER MEDIUM 5/16 ZINCPL		
	140	15G185	HXNUT 5/16-18UNC2B SAE ZINC G		
	150	15K085	HEXCAPSCR 3/8-16UNC2AX3/4 GR5		
	160	15A010	67346A CARRSCR 3/8-16UNC2X1 SPECIAL		
	170	15U255	LOKWASHER MEDIUM 3/8 ZINCPL		
	180	15G205	HXNUT 3/8-16UNC2B ZINC GR2		
	190	15K203	HXTAPSCR TFL 1/2-13X5 GR5 ZIN		
	200	15U300	LOKWASHER REGULAR 1/2 ZINC PL		
	210	15G230	HXNUT 1/2-13UNC2B SAE ZINC GR		
	220	04-22871	2004162B BED SUPP CHAN-84"LG BED		
	2004162	BED ASSY 52WX84LG	COINC11R		
	ALC50130	80	15K033	BUTSOKCAPSCR 1/4-20X5/8 SS18-	
90		15U181	LOKWASHER MEDIUM 1/4 SS18-8		
100		15U188	01Z FLTWASH 1/4 STD COMM SS18-8		
110		15G164NE	HEXLOKNUT NYL 1/4-20 UNC2A SS		
160		04-20715	2004455B BED SIDE MTG CHAN-COSHR111		
220		04-22285	2002372B ROLLER BRNG COVER 44W BED-RT		
230		04-22285A	2002372# ROLLER BRNG COVER 44W BED-LF		
390		04-23444	2005422B BED FESTOON BOX BRKT-COLFM111		
A01		15K065	HEXCAPSCR 5/16-18UNC2AX1 GR5		
A02		15U210	LOKWASHER MEDIUM 5/16 ZINCPL		
A03		15G185	HXNUT 5/16-18UNC2B SAE ZINC G		
A04		15K095	HXCPCSCR 3/8-16UNC2AX1 GR5 ZIN		
A05		15A011	CARBOLT 3/8-16UNC2X1 ZINC GR2		
A06		15U255	LOKWASHER MEDIUM 3/8 ZINCPL		
A07		15G205	HXNUT 3/8-16UNC2B ZINC GR2		
A12		15G170	HEXNUT 1/4-20UNC2 SS18-8		
P01		ALC50081C	2004162N BED FRAME 50WX84LG ASSEMBLY		
P05		04-22864	2005226D SIDE UPPER 84L BED-RT		
P06		04-22864A	2005226# SIDE UPPER 84L BED-LF		
P14		54STB3214R	91136N REDCR40 B#SF721-40T-B5-G +OIL		
P15	04-22233	2003423B TORQUE ARM GROMET MTG BRKT			
P16	04-20716	2004455B TORQARM COSHR LOWER BED-LF	...		
P17	ALC420063	95452N TORQUE ARM BUSHING ASSEMBLY			
P22	Y4-20832K	2004476D DRVRROLLER 5.75D X 63.75"OAL			
P23	ALC50131	2004162N IDLER 50W ROLLER ASSEMBLY			
P24	54AF1437	FLANGE BRG.HUBCITY FB150X1+7/1			

Parts List
COSHR 111/112



Pellerin Milnor Corporation
P. O. Box 400, Kenner, LA 70063-0400

MLQCOSHRAE/2007103B
(Sheet 4 of 7)

Litho in U.S.A.

Parts List
Find the correct assembly first, then find the needed components. The item letters (A, B, C, etc.) assigned to assemblies are referred to in the "Used In" column to identify which components belong to an assembly. The item numbers (1, 2, 3, etc.) assigned to components relate the parts list to the illustration.

Assembly	Item	Part Number	Description
ALC50131	P25	54C500V	BELT 51" GREY WDGGRIP W/VGUID
	P25A	54G201D	CLIPLACE#UX-1-36S E=1PC 3FT L
	P25B	54G301C	BLTLACERCONN #13NYL-SS EA=1FT
	2004162	IDLER 50W ROLLER ASSEMBLY	
	10	Y4-20832L	2005525D IDLER 50W ROLLER 5.75D
ALC50132	20	X4-22877	2004162D IDLER 50W ROLLER SHAFT
	30	54A018	NER 18 BALL BEARING OR =
	40	54JH10750S	SHFTCOL 3/4X1+1/2X.5 SS C-T
	50	54JH1125C	SFTCOLLAR 1+1/8 CLPTYP CFG#18
	2004413	LF/RT SIDE SLIDER-COSHR111	
ALC50133	10	W4-20707	2004474D BED SLIDER WLMT COSHR111-LF
	20	W4-20707A	2004474# BED SLIDER WLMT COSHR111-RT
	30	04-22243	2001034B MAIN SLIDER ADJ ANGLE
	50	X4-23391	98431B TRACK SLIDER UHMW BAR
	60	15K105	HXCAPSCR 3/8-16UNC2A1.25 GR5
	70	15U200	FLATWASHER(USS STD) 5/16"ZNC
	80	15G218	01Z HXLOKNUT NYL 3/8-16 STL/ZNC
	90	27B25002SZ	SPCRROLL.39ID.125L.048T STLZN
	100	15A063	CARBOLT 1/2-13UNC2X1.50 ZINC
	110	15U280	01Z FL+WASHER(USS STD)1/2 ZNC PL+
	120	15U300	LOKWASHER REGULAR 1/2 ZINC PL
	130	15G230	HXNUT 1/2-13UNC2B SAE ZINC GR
	140	ALC50155	2006323N BED LIFT GUIDE WHEEL ASSY
	ALC50134	2004413	KICKPLATE ASSEMBLY-COSHR
ALC50138	10	04-20711	2005173C SHUTL STOP KICKPLATE-COSHR
	11	04-23367A	99403B KICKPLATE GUSSET-RT
	12	04-23367B	99403# KICKPLATE GUSSET-LF
	20	04-23370	98412C KICKPLATE MTG BRKT
	30	04-23371	99111B KICKPLT SPRING SUPPORT
	40	04-23372	99341B KICKPLT SW MTG BKT
	50	01-09028	82343B SPRING=BRAKE.88OD2.5FL95#/"
	60	15K133	HXCAPSCREW 3/8-16UNC2AX3 GR5
	80	15G218	01Z HXLOKNUT NYL 3/8-16 STL/ZNC
	90	15K147	HXCAPSCR 1/2-13UNC2X1 GR5 ZIN
	100	15U286	FLATWASHER 2"ODX17/32"IDX1/4"
	110	15U300	LOKWASHER REGULAR 1/2 ZINC PL
	120	15G228	01Z HXCPNUT 1/2-13 UNC GR-2
	130	15N140	RDMACSCR 10-24UNC2AX3/4 ZINC
	140	15G126SZ	01Z HXLOKNUT 10-24 UNC STL/ZNC
	150	15K039	HXCAPSCR 1/4-20UNC2AX3/4 GR5
	160	15U180	LOKWASHER MEDIUM 1/4 ZINCPL
170	15G165	HXNUT 1/4-20UNC2BSAE ZC GR2	

Assembly	Item	Part Number	Description	Comments	
ALC50137	190	15K060	HXCAPSCR 5/16-18UNCAX3/4 GR5		
	200	15U200	FLATWASHER(USS STD) 5/16"ZNC		
	210	15U210	LOKWASHER MEDIUM 5/16 ZINCPL		
	220	15G185	HXNUT 5/16-18UNC2B SAE ZINC G		
	230	09RM01312S	03Z CAPSW 12FT 90DEG ROLLER SILVE		
	250	03-E0406	2002034B ENCL:M6 DRY PROX SW FULL OPN		
	260	03-E0406Y	91171# COVER:M6 COSHA JUNCTION BOX		
	HORZ 52WX84L BED ASSY-COSHR111				
	80	15K033	BUTSOKCAPSCR 1/4-20X5/8 SS18-		
	90	15U181	LOKWASHER MEDIUM 1/4 SS18-8		
	100	15U188	01Z FLTWASH 1/4 STD COMM SS18-8		
	110	15G164NE	HEXLOKNUT NYL 1/4-20 UNC2A SS		
	160	04-20715	2004455B BED SIDE MTG CHAN-COSHR111		
	220	04-22285	2002372B ROLLER BRNG COVER 44W BED-RT		
	230	04-22285A	2002372# ROLLER BRNG COVER 44W BED-LF		
	ALC50081C	A01	15K065	HXCAPSCR 5/16-18UNC2AX1 GR5	
A02		15U210	LOKWASHER MEDIUM 5/16 ZINCPL		
A03		15G185	HXNUT 5/16-18UNC2B SAE ZINC G		
A04		15K095	HXCPCSCR 3/8-16UNC2AX1 GR5 ZIN		
A05		15A011	CARBOLT 3/8-16UNC2X1 ZINC GR2		
A06		15U255	LOKWASHER MEDIUM 3/8 ZINCPL		
A07		15G205	HXNUT 3/8-16UNC2B ZINC GR2		
A12		15G170	HEXNUT 1/4-20UNC2 SS18-8		
P01		ALC50081C	2004162N BED FRAME 50WX84LG ASSEMBLY		
P05		04-20728	2005333D SIDE HORZBED 84LG-RT		
P06		04-20728A	2005333# SIDE HORZBED 84LG-LF		
P14		54STB3214R	91136N REDCR40 B#SF721-40T-B5-G +OIL		
P15		04-22233	2003423B TORQUE ARM GROMET MTG BRKT		
P16		04-20729	2005093C TORQARM HORZBED-COSHR111		
P17		ALC420063	95452N TORQUE ARM BUSHING ASSEMBLY		
P22		Y4-20832K	2004476D DRVROLLER 5.75D X 63.75"OAL		
P23		ALC50131	2004162N IDLER 50W ROLLER ASSEMBLY		
P24		54AF1437	FLANGE BRGHUBCITY FB150X1+7/1		
P25		54C500V	BELT 51" GREY WDGGRIP W/VGUID		
P25A		54G201D	CLIPLACE#UX-1-36S E=1PC 3FT L		
P25B	54G301C	BLTLACERCONN #13NYL-SS EA=1FT			
.ALC50138	LF/RT HORZBED SLIDER-COSHR111				
ALC50138	10	W4-20726	2005093D SLIDER HORZBED LF-COSHR111		
	20	W4-20726A	2005093# SLIDER HORZBED RT-COSHR111		
	30	04-22243	2001034B MAIN SLIDER ADJ ANGLE		
	50	X4-23391	98431B TRACK SLIDER UHMW BAR		
	60	15K105	HXCAPSCR 3/8-16UNC2A1.25 GR5		
	70	15U200	FLATWASHER(USS STD) 5/16"ZNC		
	80	15G218	01Z HXLOKNUT NYL 3/8-16 STL/ZNC		
	90	27B25002SZ	SPCRROLL.39ID.125L.048T STLZN		
	100	15A063	CARBOLT 1/2-13UNC2X1.50 ZINC		
	100	15G165	HXNUT 1/4-20UNC2BSAE ZC GR2		

Parts List
COSHR 111/112



Pellerin Milnor Corporation
P. O. Box 400, Kenner, LA 70063-0400

Litho in U.S.A.

MLQCOSHRAE/2007103B
(Sheet 5 of 7)

Parts List		
Find the correct assembly first, then find the needed components. The item letters (A, B, C, etc.) assigned to assemblies are referred to in the "Used In" column to identify which components belong to an assembly. The item numbers (1, 2, 3, etc.) assigned to components relate the parts list to the illustration.		
Assembly	Item	Description
ALC50139	2005186	HORZ 52WX84L BED ASSY-COSHR112
	110	15U280 01Z FL+WASHER(USS STD)1/2 ZNC PL+
	120	15U300 LOKWASHER REGULAR 1/2 ZINC PL
	130	15G230 HXNUT 1/2-13UNC2B SAE ZINC GR
	140	ALC50155 2006323N BED LIFT GUIDE WHEEL ASSY
	80	15K033 BUTSOKCAPSCR 1/4-20X5/8 SS18-
	90	15K042 BUTSOKCAPSCR 1/4-20NCX1 SS18-
	100	15G164NE HEXLOKNUY 1/4-20 UNC2A SS
	110	15U181 LOKWASHER MEDIUM 1/4 SS18-8
	120	15U188 01Z FLTWASH 1/4 STD COMM SS18-8
	130	15G170 HEXNUT 1/4-20UNC2 SS18-8
	210	04-22285 2002372B ROLLER BRNG COVER 44W BED-RT
	220	04-22285A 2002372# ROLLER BRNG COVER 44W BED-LF
	230	04-22287 2002375B REFLECTOR MOUNTING PLATE
	351	15U241MB FLAT WASHER-1.50D 1+1/32ID 10
	400	09RPE011 PHOTOEYE VALU-BEAM 10-30DC
	420	09RPE001A REFLECTOR 3"DIA CLEAR 3M #C11
	430	03-BF2X4W MOUNT PLT=PHOTO REFLECTOR
	A01	15K065 HEXCAPSCR 5/16-18UNC2AX1 GR5
	A02	15A008C CARBOLT 5/16-18NCX1"ZINC GR
	A03	15U210 LOKWASHER MEDIUM 5/16 ZINCPL
	A04	15G185 HXNUT 3/8-16UNC2B SAE ZINC G
	A05	15G185 HXNUT 5/16-18UNC2B SAE ZINC G
	A06	15U255 LOKWASHER MEDIUM 3/8 ZINCPL
	A07	15G205 HXNUT 3/8-16UNC2B ZINC GR2
	P04	ALC50081C 2004162N BED FRAME 50WX84LG ASSEMBLY
	P05	04-20728 2005333D SIDE HORZBED 84LG-RT
	P06	04-20728A 2005333# SIDE HORZBED 84LG-LF
	P14	54STB3214R 91136N REDCR40 B#SF721-40T-B5-G +OIL
	P15	04-20732 2005186B TORQARM UPPER BRKT COSHR-RT
	P16	04-22259 2002455B TORQARM BRKT UPPER BED-RT
	P17	ALC420063 95452N TORQUE ARM BUSHING ASSEMBLY
	P22	Y4-20832K 2004476D DRVROLLER 5.75D X 63.75"OAL
	P23	ALC50131 2004162N IDLER 50W ROLLER ASSEMBLY
	P24	54AF1437 FLANGE BRG.HUBCITY FB150X1+7/1
	P25	54C500V BELT 51" GREY WDGGRIP W/VGUID
	P25A	54G201D CLIPLACE#UX-1-36S E=1PC 3FT L
ALC50140	2005186	HORZ 54WX84L BED ASSY-COSHR112
	110	15U181 LOKWASHER MEDIUM 1/4 SS18-8
	120	15U188 01Z FLTWASH 1/4 STD COMM SS18-8
	130	15G170 HEXNUT 1/4-20UNC2 SS18-8
	190	04-20731 2005333C UNLOAD BRNG COVER COSHR-RT

Parts List, cont.				
Assembly	Item	Part Number	Description	Comments
	200	04-20731A	2005333# UNLOAD BRNG COVER COSHR-LF	
	210	04-22286	2002454B ROLLER BRNG COVER 48W BED-RT	
	220	04-22286A	2002454# ROLLER BRNG COVER 48W BED-LF	
	331	15U241MB	FLAT WASHER-1.50D 1+1/32ID 10	
	380	09RPE011	PHOTOEYE VALU-BEAM 10-30DC	
	400	09RPE001A	REFLECTOR 3"DIA CLEAR 3M #C11	
	410	03-BF2X4W	86212B MOUNT PLT=PHOTO REFLECTOR	
	A01	15K065	HEXCAPSCR 5/16-18UNC2AX1 GR5	
	A02	15A008C	CARRBOLT 5/16-18NCX1"ZINC GR	
	A03	15U210	LOKWASHER MEDIUM 5/16 ZINCPL	
	A04	15G185	HXNUT 5/16-18UNC2B SAE ZINC G	
	A05	15K095	HXCPSCR 3/8-16UNC2AX1 GR5 ZIN	
	A06	15U255	LOKWASHER MEDIUM 3/8 ZINCPL	
	A07	15G205	HXNUT 3/8-16UNC2B ZINC GR2	
	A08	15K033	BUTSOKCAPSCR 1/4-20X5/8 SS18-	
	A09	15K042	BUTSOKCAPSCR 1/4-20NCX1 SS18-	
	A10	15G164NE	HEXLOKNUY 1/4-20 UNC2A SS	
	P04	ALC50081C	2004162N BED FRAME 50WX84LG ASSEMBLY	
	P05	04-20730	2006104D SIDE LOWER HORZ 84"BED-RT	
	P06	04-20730A	2006104# SIDE LOWER HORZ 84"BED-LEFT	
	P14	54STB3214R	91136N REDCR40 B#SF721-40T-B5-G +OIL	
	P15	04-22233	2003423B TORQUE ARM GROMET MTG BRKT	
	P16	04-20729	2005093C TORQARM HORZBED-COSHR111	
	P17	ALC420063	95452N TORQUE ARM BUSHING ASSEMBLY	
	P22	Y4-20832K	2004476D DRVROLLER 5.75D X 63.75"OAL	
	P23	ALC50131	2004162N IDLER 50W ROLLER ASSEMBLY	
	P24	54AF1437	FLANGE BRG.HUBCITY FB150X1+7/1	
	P25	54C500V	BELT 51" GREY WDGGRIP W/VGUID	
	P25A	54G201D	CLIPLACE#UX-1-36S E=1PC 3FT L	
	P25B	54G301C	BLTLACERCONN #13NYL-SS EA=1FT	
ALC50141	2005186	LF/RT HORZBED SLIDER-COSHR112		
	10	W4-20737	2005186D SIDE SLIDER HORZ COSHR112-LF	
	20	W4-20737A	2005186# SIDE SLIDER HORZ COSHR112-RT	
	30	04-22243	2001034B MAIN SLIDER ADJ ANGLE	
	40	04-20736	2005186B UPPER BED SLIDER ANGLE-COSHR	
	50	X4-23391	98431B TRACK SLIDER UHMW BAR	
	60	15K105	HXCAPSCR 3/8-16UNC2A1.25 GR5	
	70	15U200	FLATWASHER(USS STD) 5/16"ZNC	
	80	15G218	01Z HXLOKNUY 3/8-16 STL/ZNC	
	90	27B250	02SZ SPCRROLL.39ID.125L.048T STLZN	
	100	02-19283	86477B NUT=1/2-13UNCX1+1/2SQ SPEC	
	101	15K153H	INDHEXFLGSCR1/2-13X1+1/4GR8ZN	
	110	X4-23410	2001075B UHMW BED STOP BLOCK	
	120	15N173	FLATMACSCR 1/4-20NCX5/8SS18-8	
	121	15G166A	01Z HXLOKNUY 1/4-20 UNC2A STL	
	130	15K085	HEXCAPSCR 3/8-16UNC2AX3/4 GR5	
	140	15A012	FLATWASHER(USS STD) 3/8" ZNC	
	160	15U255	LOKWASHER MEDIUM 3/8 ZINCPL	
	170	15G205	HXNUT 3/8-16UNC2B ZINC GR2	

Parts List
COSHR 111/112



Pellerin Milnor Corporation
P. O. Box 400, Kenner, LA 70063-0400

Litho in U.S.A.

MLQCOSHRAE/2007103B
(Sheet 6 of 7)

Parts List		
Find the correct assembly first, then find the needed components. The item letters (A, B, C, etc.) assigned to assemblies are referred to in the "Used In" column to identify which components belong to an assembly. The item numbers (1, 2, 3, etc.) assigned to components relate the parts list to the illustration.		
Assembly	Item	Description
	180	CARBOLT 1/2-13UNC2X1.50 ZINC
	190	01Z FL+WASHER(USS STD)1/2 ZNC PL+
	200	LOKWASHER REGULAR 1/2 ZINC PL
	210	HXNUT 1/2-13UNC2B SAE ZINC GR
	220	2006323N BED LIFT GUIDE WHEEL ASSY
ALC50142		UPPER SLIDING PAD ASSY-COSHR
	10	2002233B UPPER BED SLIDER PAD
	30	HXCAPSCR 3/8-16UNC2A1.25 GR5
	40	01Z HXLKNUIT NYL 3/8-16 STL/ZNC
	50	FLATWASHER(USS STD) 5/16"ZNC
	60	SPCRROLL.39ID.562L.048T STLZN
	70	SPCRROLL.39ID.125L.048T STLZN
	80	2005186C UPPER BED SLIDER WLMT-COSHR11
ALC50143		2005186 HORZBED LIFT FRAME-COSHR112
	10	2005186Z LF/RT HORZBED SLIDER-COSHR112
	20	UPPER SLIDING PAD ASSY-COSHR
	25	2005186D UPPER HORZBED MTG COSHR-LF
	26	2005186# UPPER HORZBED MTG COSHR-RT
	30	2004474C BED LIFTING CHANNEL-COSHR
	40	2004474C BED LIFTING CHAN SPACER-COSHR
	50	2006035C BED LIFT PLATE WLMT
	60	HXCAPSCR 1/2-13UNC24X1.25 GR5
	70	LOKWASHER REGULAR 1/2 ZINC PL
	80	HXNUT 1/2-13UNC2B SAE ZINC GR
	91	2003316A SKCSPC3/8-16 UNC3 X 1.5 BLK
	100	HEXLIGHTLOKNUIT 3/8-16 18-8SS
	110	CLEVIS PIN 1/2"X1+3/8" DRILLE
	120	STDCOTTERPIN 1/8X3/4 ZINCPL
	130	01Z FL+WASHER(USS STD)1/2 ZNC PL+
	140	2005093C SLACHCHAIN SPRING COVER-COSHR
	150	2006434B SPRING=OUTER DOOR 60 WEHU
	160	RDMACSCR 10-24NCX3/4 SLOTTED
	170	01Z HXLKNUIT NYLON 10-24 UNC SS
ALC50145		R M 1385.27988 2005186 BED ASSY 52WX84LG-COSHR112
	80	BUTSOKCAPSCR 1/4-20X5/8 SS18-
	90	BUTSOKCAPSCR 1/4-20NCX1 SS18-
	100	15G164NE
	110	HEXLKNUIT NYL 1/4-20 UNC2A SS
	120	LOKWASHER MEDIUM 1/4 SS18-8
	130	01Z FLTWASH 1/4 STD COMM SS18-8
	15G170	HEXNUT 1/4-20UNC2 SS18-8
	04-20959A	2005226# TOP BED MTG PL COSHR112-RT

Parts List, cont.				
Assembly	Item	Part Number	Description	Comments
	215	04-20750B	85243B CHANNEL=PAD CLAMP FESTOON	
	222	04-22287	2002375B REFLECTOR MOUNTING PLATE	
	230	04-22285	2002372B ROLLER BRNG COVER 44W BED-RT	
	231	04-22285A	2002372# ROLLER BRNG COVER 44W BED-LF	
	400	09RPE011	PHOTOEYE VALU-BEAM 10-30DC	
	420	09RPE001A	REFLECTOR 3"DIA CLEAR 3M #C11	
	430	03-BF2X4W	86212B MOUNT PLT=PHOTO REFLECTOR	
	A01	15K065	HEXCAPSCR 5/16-18UNC2AX1 GR5	
	A02	15A008C	CARBOLT 5/16-18NCX1"ZINC GR	
	A03	15U210	LOKWASHER MEDIUM 5/16 ZINCPL	
	A04	15G185	HXNUT 5/16-18UNC2B SAE ZINC G	
	A05	15K095	HXCAPSCR 3/8-16UNC2AX1 GR5 ZIN	
	A06	15U255	LOKWASHER MEDIUM 3/8 ZINCPL	
	A07	15G205	HXNUT 3/8-16UNC2B ZINC GR2	
	P04	ALC50081C	2004162N BED FRAME 50WX84LG ASSEMBLY	
	P05	04-22864	2005226D SIDE UPPER 84L BED-RT	
	P06	04-22864A	2005226# SIDE UPPER 84L BED-LF	
	P09	04-20959	2005226D TOP BED MTG PL COSHR112-LF	
	P14	54STB3214R	91136N REDCR40 B#SF721-40T-B5-G +OIL	
	P15	04-20733	2005186B TORQARM UPPERBED COSHR-RT	
	P16	04-22259	2002455B TORQARM BRKT UPPER BED-RT	
	P17	ALC420063	95452N TORQUE ARM BUSHING ASSEMBLY	
	P22	Y4-20832K	2004476D DRVROLLER 5.75D X 63.75"OAL	
	P23	ALC50131	2004162N IDLER 50W ROLLER ASSEMBLY	
	P24	54AF1437	FLANGEBRGHUBCITY FB150X1+7/1	
	351	15U241MB	FLAT WASHER-1.50D 1+1/32ID 10	
	P25	54C500V	BELT 51" GREY WDGGRIP W/VGUID	
	P25A	54G201D	CLIPLACE#UX-1-36S E=1PC 3FT L	
	P25B	54G301C	BLTLACERCONN #13NYL-SS EA=1FT	
ALC50146		BED ASSY 54WX84LG-COSHR112		
	110	15U181	LOCKWASHER MEDIUM 1/4 SS18-8	
	120	15U188	01Z FLTWASH 1/4 STD COMM SS18-8	
	130	15G170	HEXNUT 1/4-20UNC2 SS18-8	
	190	04-20731	2005333C UNLOAD BRNG COVER COSHR-RT	
	191	04-20731A	2005333# UNLOAD BRNG COVER COSHR-LF	
	200	04-22286	2002454B ROLLER BRNG COVER 48W BED-RT	
	201	04-22286A	2-1.50D 1+1/32ID 10	
	380	09RPE011	PHOTOEYE VALU-BEAM 10-30DC	
	400	09RPE001A	REFLECTOR 3"DIA CLEAR 3M #C11	
	410	03-BF2X4W	86212B MOUNT PLT=PHOTO REFLECTOR	
	420	09X350AT	01Z MULT CABLE/HOSE CARRIER	
	440	03-E0406	2002034B ENCL:M6 DRY PROX SW FULL OPN	
	450	03-E0406Y	91171# COVER:M6 COSHA JUNCTION BOX	
	A01	15K065	HEXCAPSCR 5/16-18UNC2AX1 GR5	
	A02	15A008C	CARBOLT 5/16-18NCX1"ZINC GR	
	A03	15U210	LOKWASHER MEDIUM 5/16 ZINCPL	
	A04	15G185	HXNUT 5/16-18UNC2B SAE ZINC G	

Parts List
COSHR 111/112

MLQCOSHRAE/2007103B
(Sheet 7 of 7)



Pellerin Milnor Corporation
P. O. Box 400, Kenner, LA 70063-0400

Litho in U.S.A.

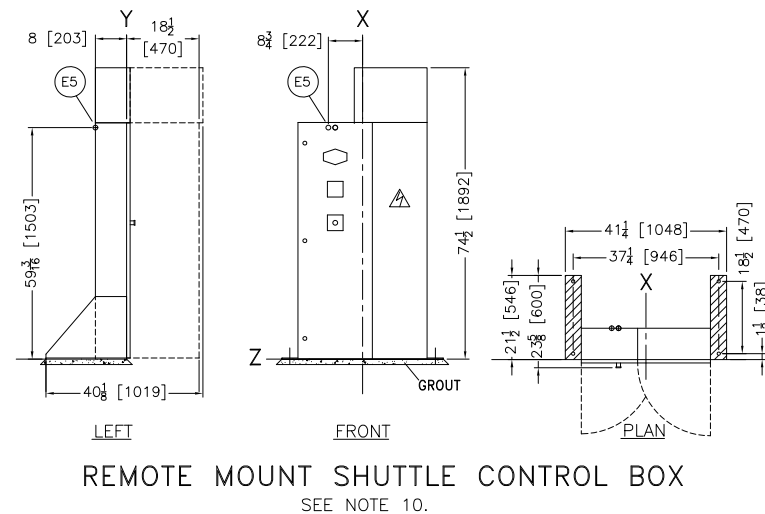
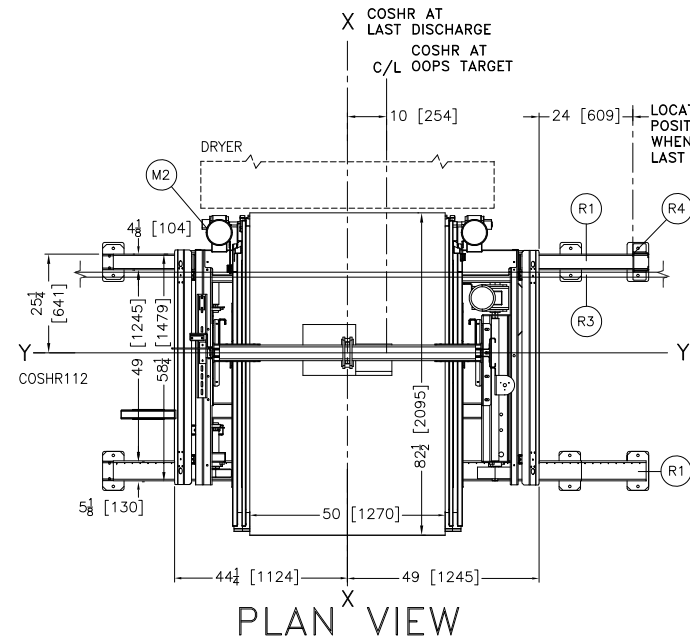
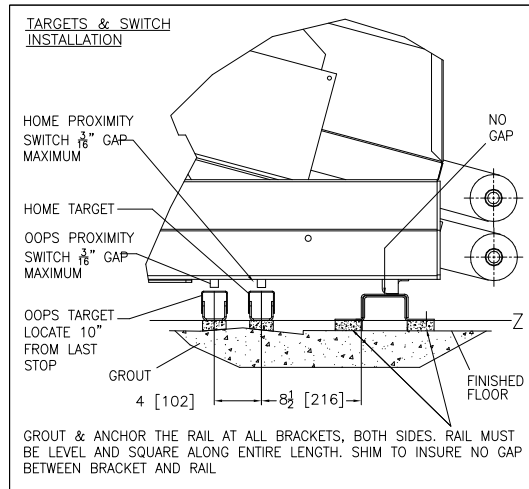
Parts List		Parts List, cont.	
Assembly	Item	Part Number	Description
Find the correct assembly first, then find the needed components. The item letters (A, B, C, etc.) assigned to assemblies are referred to in the "Used In" column to identify which components belong to an assembly. The item numbers (1, 2, 3, etc.) assigned to components relate the parts list to the illustration.			
	A05	15K095	HXCPSR 3/8-16UNC2AX1 GR5 ZIN
	A06	15U255	LOCKWASHER MEDIUM 3/8 ZINCPL
	A07	15G205	HXNUT 3/8-16UNC2B ZINC GR2
	A08	15K033	BUTSOKCAPSCR 1/4-20X5/8 SS18-
	A09	15K042	BUTSOKCAPSCR 1/4-20NCX1 SS18-
	A10	15G164NE	HEXLOKNUT NYL 1/4-20 UNC2A SS
	P04	ALC50081C	2004162N BED FRAME 50WX84LG ASSEMBLY
	P05	04-20958	2006104D SIDE LOWER 84L BED-RT
	P06	04-20958A	2006104# SIDE LOWER 84L BED-LF
	P14	54STB3214R	91136N REDCR40 B#SF721-40T-B5-G +OIL
	P15	04-22233	2003423B TORQUE ARM GROMET MTG BRKT
	P16	04-20716	2004455B TORQARM COSHR LOWER BED-LF
	P17	ALC420063	95452N TORQUE ARM BUSHING ASSEMBLY
	P22	Y4-20832K	2004476D DRVROLLER 5.75D X 63.75"OAL
	P23	ALC50131	2004162N IDLER 50W ROLLER ASSEMBLY
	P24	54AF1437	FLANGE BRG.HUBCITY FB150X1+7/1
	P25	54C500V	BELT 51" GREY WDGGRIP W/VGUID
	P25A	54G201D	CLIPLACE#UX-1-36S E=1PC 3FT L
	P25B	54G301C	BLTLACERCONN #13NYL-SS EA=1FT
ALC50155	2006323	BED LIFT GUIDE	WHEEL ASSY
	10	X4-23480	2006323B BED LIFT GUIDE WHEEL-PVC
	20	X4-23481	2006323B BED LIFT WHEEL SS SPACER
	30	15K173A	HXCAPSCR 1/2-13UNC2AX1.75
	40	15U280	01Z FL+WASHER(USS STD)1/2 ZNC
	50	15G222B	HEXFLGNUT 1/2-13 ZINC
Y4 20832K	2004476	DRVROLLER 5.75D X 63.75"OAL	

Dimensional Drawings

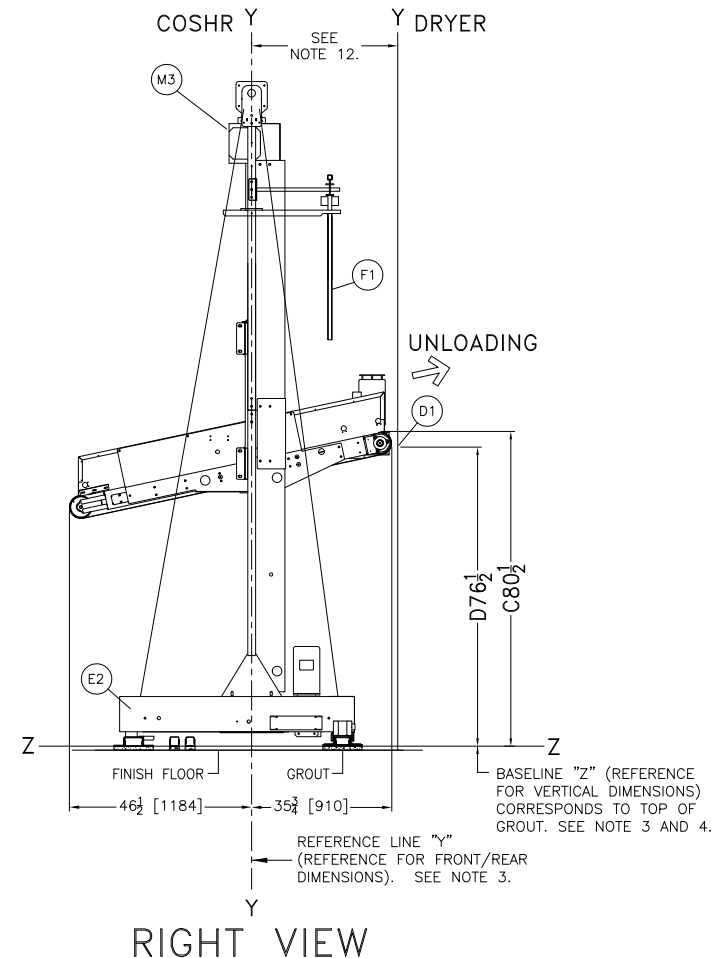
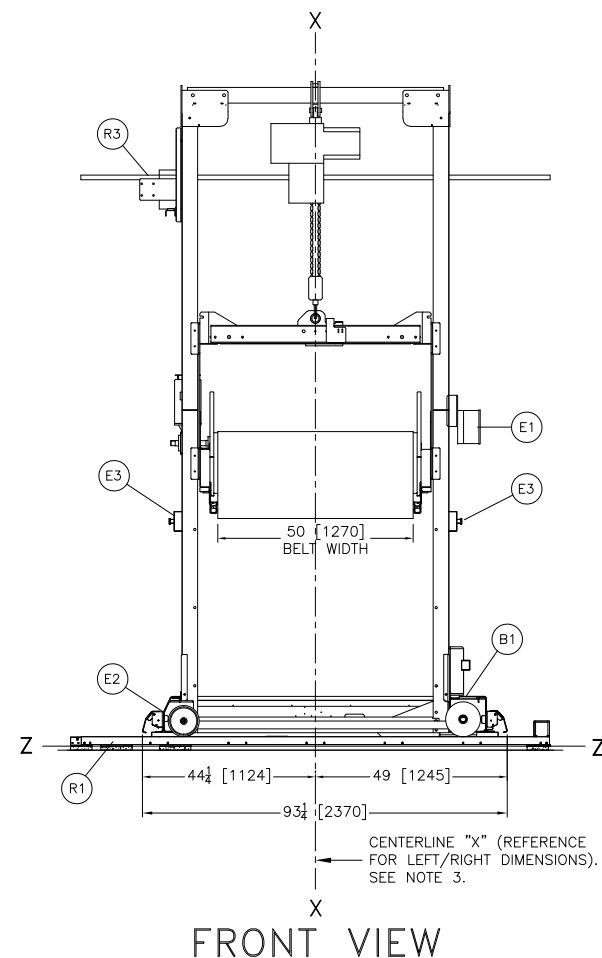
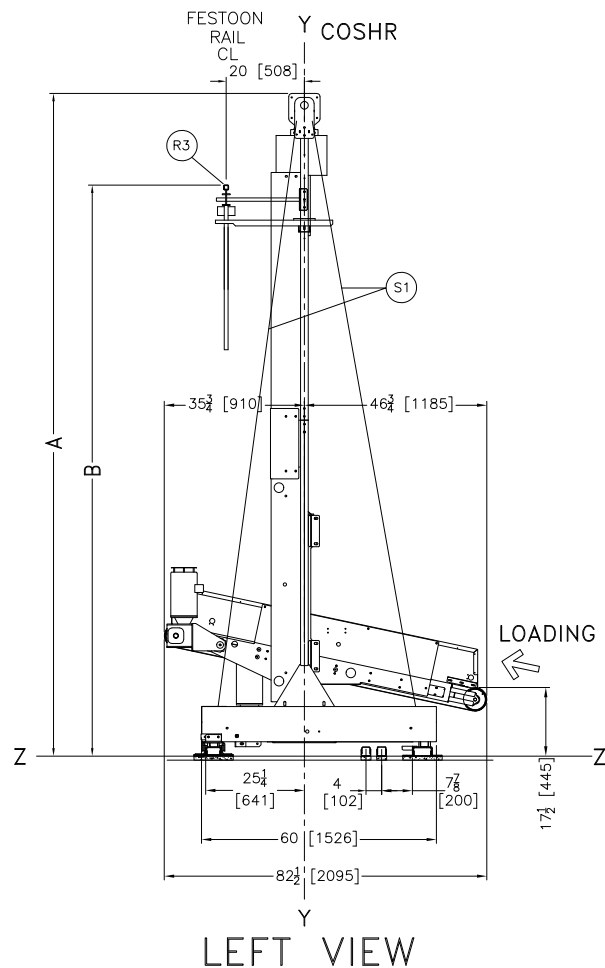
4

WHEN THIS DRYER PEDESTAL EXTENDER IS USED WITH DRYER 8282		WHEN THIS DRYER PEDESTAL EXTENDER IS USED WITH DRYER 7676		WHEN THIS DRYER PEDESTAL EXTENDER IS USED WITH DRYER 6458,6464		USE THIS SIDE RAIL EXTENDER COSHR111		COSHR111 DIMENSIONS								DIMENSION "D" 6458,6464 LOAD HEIGHT		DIMENSION "D" 7676,8282 LOAD HEIGHT			
INCHES	mm	INCHES	mm	INCHES	mm	INCHES	mm	DIMENSION "A"		DIMENSION "B" WITH 6458,6464		DIMENSION "B" WITH 7676		DIMENSION "C" WITH 6458,6464		DIMENSION "C" WITH 7676,8282		INCHES	mm	INCHES	mm
		-7	-178	0	0	65 1/2	1664	159 1/2	4051	132 1/2	3366	135 1/2	3442	71	1803	73 1/2	1867	68 1/2	1740		
		-3 1/2	-89	3 1/2	89	69	1753	163	4140	136	3454	139	3531	74 1/2	1892	77	1956	72	1829	69 1/2	1765
		0	0	7	178	72 1/2	1841	166 1/2	4229	139 1/2	3543	142 1/2	3619	78	1981	80 1/2	2045	75 1/2	1918	73	1854
0	0	3 1/2	89	10 1/2	267	76	1930	170	4318	143	3632	146	3708	81 1/2	2070	84	2134	79	2007	76 1/2	1943
3 1/2	89	7	178	14	356	79 1/2	2019	173 1/2	4407	146 1/2	3721	149 1/2	3797	85	2159	86	2184	82 1/2	2096	80	2032
10 1/2	267	14	356	17 1/2	445	83	2108	177	4496	150	3810	153	3886	88 1/2	2248	87 1/2	2223	86	2184	83 1/2	2121
17 1/2	445	21	533	24 1/2	622	90	2286	184	4674	157	3988	160	4064	95 1/2	2426	94 1/2	2400	93	2362	90 1/2	2299
				31 1/2	800	97	2464	191	4851	164	4166	167	4242	102 1/2	2604	101 1/2	2578	100	2540	97 1/2	2477

* FOR HIGHER PEDESTALS, CONSULT FACTORY.



ITEM	LEGEND
S1	TIE RODS, SUPPLIED ONLY FOR SHUTTLES WITH 48" [1624] EXTENDERS OR LONGER.
R4	POSITIVE STOP
R3	FESTOON RAIL. RAIL SUPPLIED BY MILNOR AND MAY BE PRICED SEPARATELY. SEE PRICE LIST.
R1	FLOOR DRIVE RAILS. RAIL SUPPLIED BY MILNOR AND MAY BE PRICED SEPARATELY. SEE PRICE LIST.
M3	HOIST MOTOR AND WINCH.
M2	BELT MOTORS, ALTERNATES LEFT/RIGHT PER LEVEL.
M1	DRIVE MOTOR, UNDER CART FRAME, NOT VISIBLE.
F1	FESTOON CABLE
E5	ELECTRICAL & CONTROL CABLE CONNECTIONS FOR REMOTE SHUTTLE CONTROL BOX
E3	EMERGENCY STOP BUTTON
E2	EMERGENCY STOP KICK PLATE
E1	JUNCTION BOX
D1	LOAD DOOR SHELF
B1	CART FRAME WELDMENT



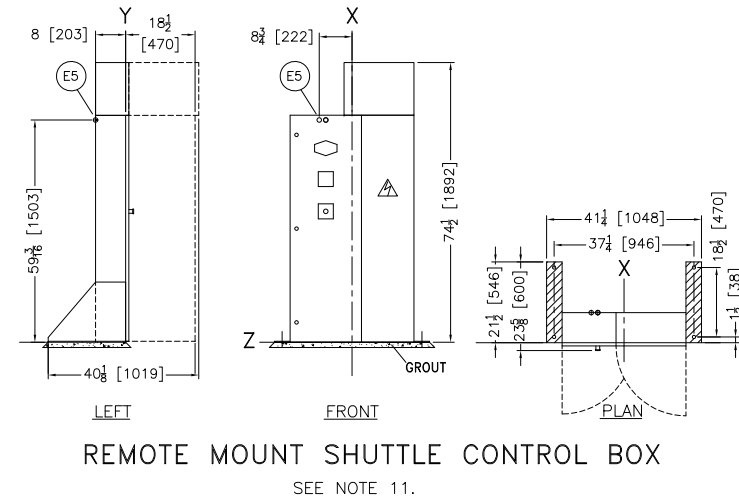
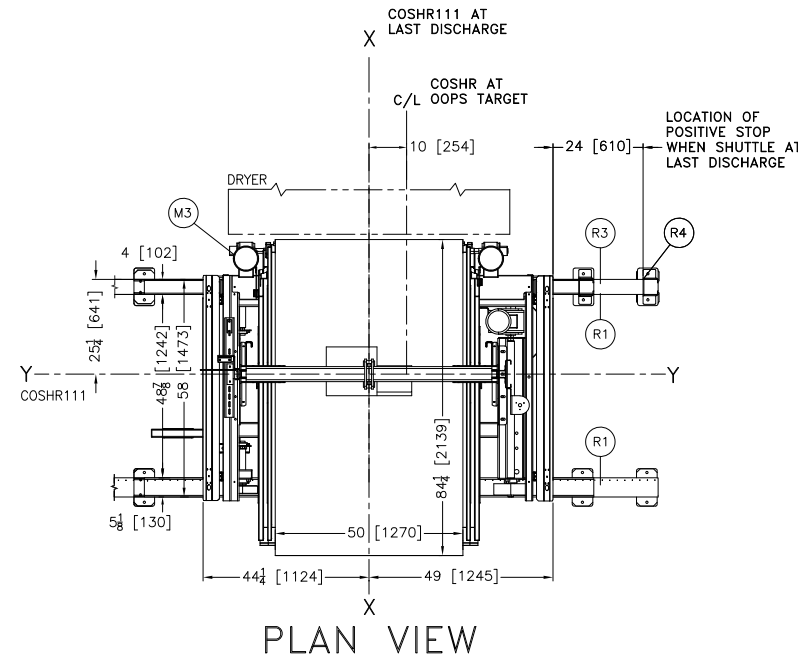
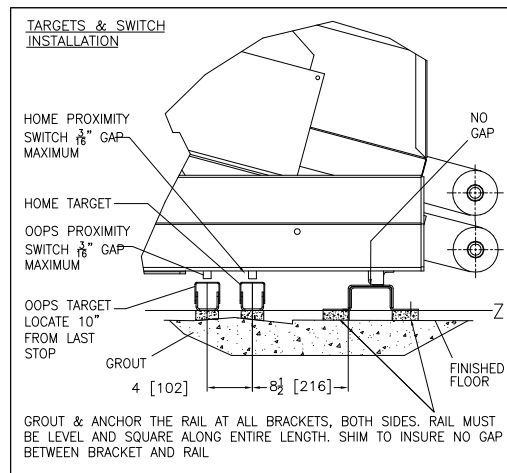
- NOTES**
- FOR THE DIMENSION FROM "Y" OF THE SHUTTLE TO "Y" OF THE DRYER. SEE DRYER DIMENSIONAL DRAWING.
 - THE 6458 DRYER AT "ZERO PEDESTAL" HAS A 41" [1041] HIGH BASE. THE DRYER MAY BE ORDERED TO INCREASE OR DECREASE THE MACHINE HEIGHT. THEREFORE, NEGATIVE PEDESTAL HEIGHTS ARE POSSIBLE. CONSULT MILNOR FACTORY.
 - CONTROLS FOR THE SHUTTLE ARE CONTAINED IN THIS REMOTELY MOUNTED SHUTTLE CONTROL BOX WHICH MUST BE PLACED IN THE EQUIPMENT LAYOUT.
 - DIMENSION VARIES WITH HEIGHT OF EXTENDERS WHEN ADDED.
 - EMERGENCY STOPS ARE REQUIRED ON BOTH LEFT AND RIGHT SIDES OF THE SHUTTLE. A THIRD EMERGENCY STOP IS INSTALLED INTO THE DOOR OF THE REMOTE SHUTTLE CONTROL BOX.
 - AFTER MACHINE HAS BEEN COMMISSIONED, BELT MAY STRETCH SLIGHTLY REQUIRING ADJUSTMENT OF BELT ROLLERS AND SLIGHT LENGTHENING OF CONVEYOR.
 - AS OF THIS WRITING, THE MINIMUM CLEARANCE REQUIRED BY U.S. NATIONAL ELECTRIC CODES, FROM ELECTRIC BOX TO ANY OBJECT IS:
 - 36 [914] IF OBJECT IS AN UNGROUNDED (INSULATED) WALL.
 - 42 [1067] IF OBJECT IS A GROUNDED WALL (i.e. BARE CONCRETE, BRICK, ETC.)
 - 48 [1219] IF OBJECT IS ANY LIVE PART.
 CHECK LOCAL ELECTRIC CODES FOR FURTHER RESTRICTIONS.
 - CUSTOMER TO SUPPLY CIRCUIT BREAKER OR FUSED BRANCH CIRCUIT DISCONNECT (SAFETY) SWITCHES WITH LAG TYPE FUSES FROM POWER SOURCE TO MACHINE. A SEPARATE GROUND WIRE MUST BE CONNECTED FROM DISCONNECT TO EQUIPMENT.
 - BASELINE "Z" IS THE SAME FOR ALL MILNOR MACHINES AND IS SHOWN ON ALL DIMENSIONAL DRAWINGS. THE DISTANCE BETWEEN BASELINE "Z" AND THE FINISHED FLOOR MAY VARY (WITH CHANGES IN FLOOR HEIGHT) AS REQUIRED TO INSURE THAT BASELINE "Z" IS HORIZONTAL AND ALL COMPONENTS REQUIRING GROUT ARE SET ON A MINIMUM 1" [25] THICK GROUT BED.
 - USE REFERENCE LINES "X", "Y", AND "Z" TO LOCATE ALL SERVICE CONNECTIONS.
 - NUMBERS IN BRACKETS [] DENOTE DIMENSIONS IN MILLIMETERS.
 - ALL DIMENSIONS SHOWN ARE APPROXIMATE, SUBJECT TO NORMAL MANUFACTURING TOLERANCES, AND TO OCCASIONAL CHANGES WITHOUT NOTICE THROUGH REDESIGN AND/OR RELOCATION OF COMPONENTS, ETC. DO NOT USE FOR CONSTRUCTION UNLESS CERTIFIED, AND IN NO EVENT PRE-PIPE CLOSER THAN FIVE FEET FROM MACHINE. FACTORY MUST BE CONSULTED FOR DIMENSIONS IF MACHINE IS TO BE MOVED THROUGH NARROW OR LOW CORRIDORS OR OPENINGS.
- ATTENTION**
- MOST REGULATORY AUTHORITIES (INCLUDING OSHA IN THE USA) HOLD THE OWNER/USER ULTIMATELY RESPONSIBLE TO MAINTAIN A SAFE WORKING ENVIRONMENT. ACCORDINGLY, THE OWNER/USER MUST RECOGNIZE ALL FORESEEABLE SAFETY HAZARDS, FURNISH SAFETY INSTRUCTIONS AND GUIDANCE TO ALL PERSONNEL WHO MAY COME IN CONTACT WITH THE INSTALLATION, AND PROVIDE ALL NECESSARY ADDITIONAL SAFETY GUARDS, FENCES, RESTRAINTS, DEVICES, ETC., NOT FURNISHED BY THE EQUIPMENT MANUFACTURER OR VENDOR.
- ATTENTION**
- THE FLOOR AND/OR OTHER SUPPORT COMPONENTS MUST HAVE SUFFICIENT STRENGTH (AND RIGIDITY WITH DUE CONSIDERATION FOR NATURAL OR RESONANT FREQUENCY THEREOF) TO WITHSTAND THE FULLY LOADED WEIGHT OF THE MACHINE INCLUDING THE GOODS, THE WATER, AND ANY REPEATED SINUSOIDAL (ROTATING) FORCES GENERATED DURING ITS OPERATION. WRITE THE FACTORY FOR ADDITIONAL MACHINE DATA FOR USE BY A COMPETENT SOIL AND/OR STRUCTURAL ENGINEER.

COSHR111 (120K)

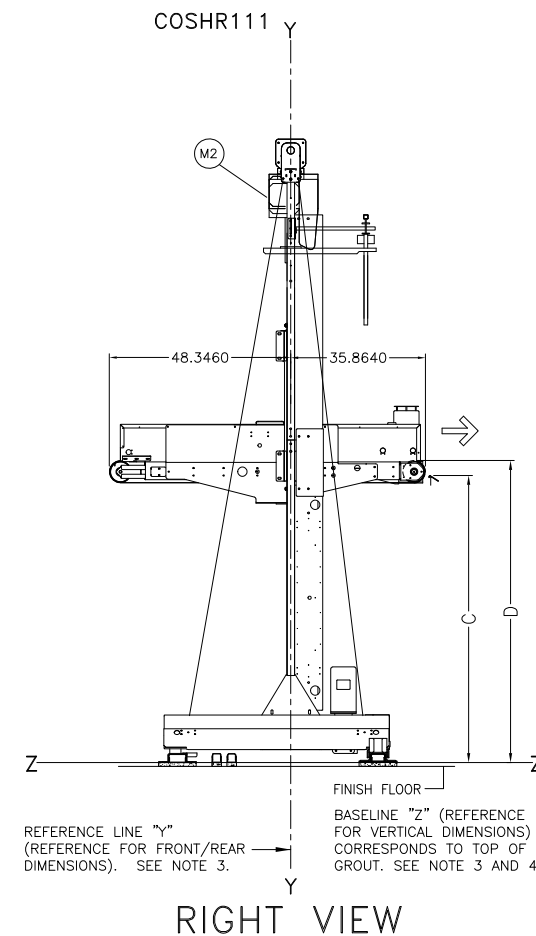
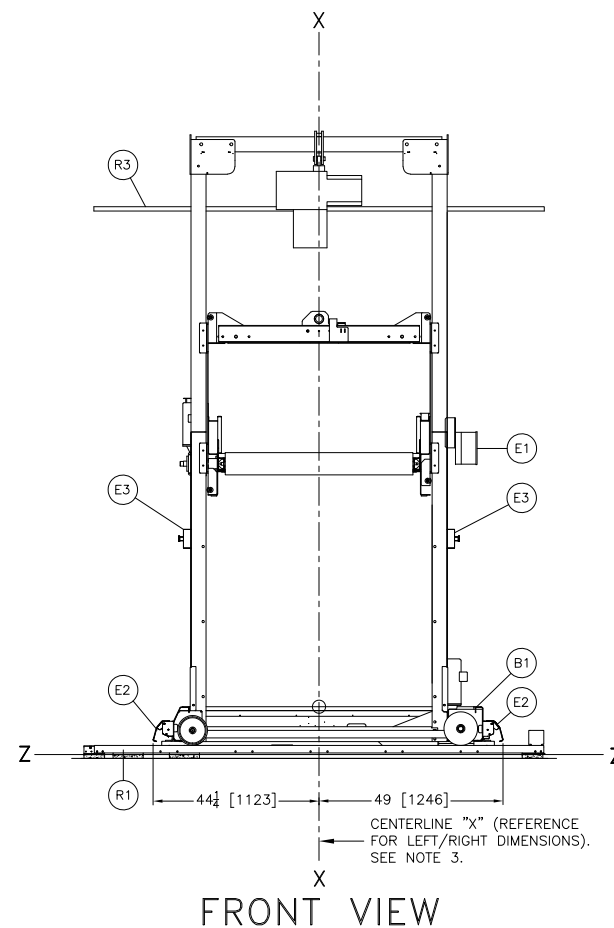
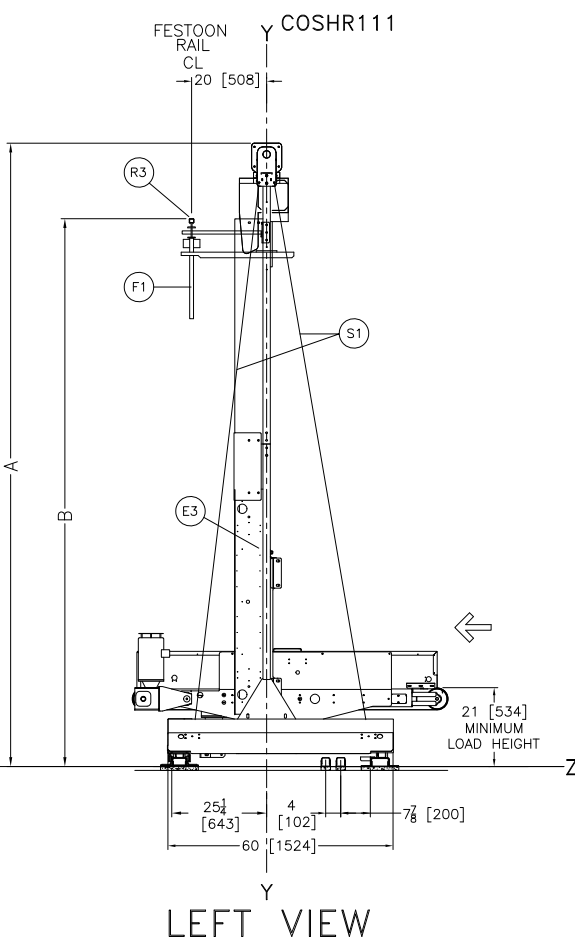
DWG# BDCOSHR1AE
 2023333D
 P.O. Box 400 Kenner, LA 70063, USA, Phone 504/467-9591,
 FAX 504/468-3094, Email: milnorinfo@milnor.com

WHEN THIS DRYER PEDESTAL EXTENDER IS USED WITH DRYER 8282		WHEN THIS DRYER PEDESTAL EXTENDER IS USED WITH DRYER 7676		WHEN THIS DRYER PEDESTAL EXTENDER IS USED WITH DRYER 6458,6464		USE THIS SIDE RAIL EXTENDER COSHR111		COSHR111 HORIZONTAL BEDS								DIMENSION "D" 6458,6464 LOAD HEIGHT		DIMENSION "D" 7676,8282 LOAD HEIGHT					
INCHES	mm	INCHES	mm	INCHES	mm	INCHES	mm	DIMENSION "A"		DIMENSION "B" WITH 6458,6464		DIMENSION "B" WITH 7676		DIMENSION "C" WITH 6458,6464		DIMENSION "C" WITH 7676,8282		INCHES	mm	INCHES	mm		
		-7	-178	0	0	65 1/2	1664	159 1/2	4051	132 1/2	3366	135 1/2	3442	71	1803	73 1/2	1867	68 1/2	1740	72	1829	69 1/2	1765
		-3 1/2	-89	7	178	72 1/2	1842	166 1/2	4229	139 1/2	3543	142 1/2	3619	78	1981	76 1/2	1943	75 1/2	1918	75 1/2	1918	73	1854
		0	0	10 1/2	267	76	1930	170	4318	143	3632	146	3708	81 1/2	2070	80 1/2	2045	79	2007	79	2007	76 1/2	1943
0	0	3 1/2	89	14	356	79 1/2	2019	173 1/2	4407	146 1/2	3721	149 1/2	3797	85	2159	84	2134	82 1/2	2096	82 1/2	2096	80	2032
3 1/2	89	7	178	17 1/2	444	83	2108	177	4496	150	3810	153	3886	88 1/2	2248	87 1/2	2222	86	2184	86	2184	83 1/2	2121
10 1/2	267	14	356	24 1/2	622	90	2286	184	4674	157	3988	160	4064	95 1/2	2426	94 1/2	2400	93	2362	93	2362	90 1/2	2299
17 1/2	445	21	533	31 1/2	800	97	2464	191	4851	164	4166	167	4242	102 1/2	2604	101 1/2	2578	100	2540	100	2540	97 1/2	2476

* FOR HIGHER PEDESTALS, CONSULT FACTORY.



ITEM	LEGEND
S1	TIE RODS, SUPPLIED ONLY FOR SHUTTLES WITH 48" [1624] EXTENDERS OR LONGER.
R4	POSITIVE STOP
R3	FESTOON RAIL. RAIL SUPPLIED BY MILNOR AND MAY BE PRICED SEPARATELY. SEE PRICE LIST.
R1	FLOOR DRIVE RAILS. RAIL SUPPLIED BY MILNOR AND MAY BE PRICED SEPARATELY. SEE PRICE LIST.
M3	HOIST MOTOR AND WINCH.
M2	BELT MOTORS, ALTERNATES LEFT/RIGHT PER LEVEL.
M1	DRIVE MOTOR, UNDER CART FRAME, NOT VISIBLE.
F1	FESTOON CABLE
E5	ELECTRICAL & CONTROL CABLE CONNECTIONS FOR REMOTE SHUTTLE CONTROL BOX
E3	EMERGENCY STOP BUTTON
E2	EMERGENCY STOP KICK PLATE
E1	JUNCTION BOX
D1	LOAD DOOR SHELF
B1	CART FRAME WELDMENT



- NOTES**
- FOR THE DIMENSION FROM "Y" OF THE SHUTTLE TO "Y" OF THE DRYER. SEE DRYER DIMENSIONAL DRAWING.
 - THE 6458 DRYER AT "ZERO PEDESTAL" HAS A 41" [1041] HIGH BASE. THE DRYER MAY BE ORDERED TO INCREASE OR DECREASE THE MACHINE HEIGHT. THEREFORE, NEGATIVE PEDESTAL HEIGHTS ARE POSSIBLE. CONSULT MILNOR FACTORY.
 - CONTROLS FOR THE COSHR SHUTTLE ARE CONTAINED IN THIS REMOTELY MOUNTED SHUTTLE CONTROL BOX WHICH MUST BE PLACED IN THE EQUIPMENT LAYOUT.
 - DIMENSION VARIES WITH HEIGHT OF EXTENDERS WHEN ADDED.
 - EMERGENCY STOPS ARE REQUIRED ON BOTH LEFT AND RIGHT SIDES OF THE SHUTTLE. A THIRD EMERGENCY STOP IS INSTALLED INTO THE DOOR OF THE REMOTE SHUTTLE CONTROL BOX.
 - AFTER MACHINE HAS BEEN COMMISSIONED, BELT MAY STRETCH SLIGHTLY REQUIRING ADJUSTMENT OF BELT ROLLERS AND SLIGHT LENGTHENING OF CONVEYOR.
 - AS OF THIS WRITING, THE MINIMUM CLEARANCE REQUIRED BY U.S. NATIONAL ELECTRIC CODES, FROM ELECTRIC BOX TO ANY OBJECT IS:
 - 36 [914] IF OBJECT IS AN UNGROUNDED (INSULATED) WALL.
 - 42 [1067] IF OBJECT IS A GROUNDED WALL (ie. BARE CONCRETE, BRICK, ETC.)
 - 48 [1219] IF OBJECT IS ANY LIVE PART.
 CHECK LOCAL ELECTRIC CODES FOR FURTHER RESTRICTIONS.
 - CUSTOMER TO SUPPLY CIRCUIT BREAKER OR FUSED BRANCH CIRCUIT DISCONNECT (SAFETY) SWITCHES WITH LAG TYPE FUSES FROM POWER SOURCE TO MACHINE. A SEPARATE GROUND WIRE MUST BE CONNECTED FROM DISCONNECT TO EQUIPMENT.
 - BASELINE "Z" IS THE SAME FOR ALL MILNOR MACHINES AND IS SHOWN ON ALL DIMENSIONAL DRAWINGS. THE DISTANCE BETWEEN BASELINE "Z" AND THE FINISHED FLOOR MAY VARY (WITH CHANGES IN FLOOR HEIGHT) AS REQUIRED TO INSURE THAT BASELINE "Z" IS HORIZONTAL AND ALL COMPONENTS REQUIRING GROUT ARE SET ON A MINIMUM 1" [25] THICK GROUT BED.
 - USE REFERENCE LINES "X", "Y", AND "Z" TO LOCATE ALL SERVICE CONNECTIONS.
 - NUMBERS IN BRACKETS [] DENOTE DIMENSIONS IN MILLIMETERS.
 - ALL DIMENSIONS SHOWN ARE APPROXIMATE, SUBJECT TO NORMAL MANUFACTURING TOLERANCES, AND TO OCCASIONAL CHANGES WITHOUT NOTICE THROUGH REDESIGN AND/OR RELOCATION OF COMPONENTS, ETC. DO NOT USE FOR CONSTRUCTION UNLESS CERTIFIED, AND IN NO EVENT PRE-PIPE CLOSER THAN FIVE FEET FROM MACHINE. FACTORY MUST BE CONSULTED FOR DIMENSIONS IF MACHINE IS TO BE MOVED THROUGH NARROW OR LOW CORRIDORS OR OPENINGS.
- ATTENTION**
- MOST REGULATORY AUTHORITIES (INCLUDING OSHA IN THE USA) HOLD THE OWNER/USER ULTIMATELY RESPONSIBLE TO MAINTAIN A SAFE WORKING ENVIRONMENT. ACCORDINGLY, THE OWNER/USER MUST RECOGNIZE ALL FORESEEABLE SAFETY HAZARDS, FURNISH SAFETY INSTRUCTIONS AND GUIDANCE TO ALL PERSONNEL WHO MAY COME IN CONTACT WITH THE INSTALLATION, AND PROVIDE ALL NECESSARY ADDITIONAL SAFETY GUARDS, FENCES, RESTRAINTS, DEVICES, ETC., NOT FURNISHED BY THE EQUIPMENT MANUFACTURER OR VENDOR.
- ATTENTION**
- THE FLOOR AND/OR OTHER SUPPORT COMPONENTS MUST HAVE SUFFICIENT STRENGTH (AND RIGIDITY WITH DUE CONSIDERATION FOR NATURAL OR RESONANT FREQUENCY THEREOF) TO WITHSTAND THE FULLY LOADED WEIGHT OF THE MACHINE INCLUDING THE GOODS, THE WATER, AND ANY REPEATED SINUSOIDAL (ROTATING) FORCES GENERATED DURING ITS OPERATION. WRITE THE FACTORY FOR ADDITIONAL MACHINE DATA FOR USE BY A COMPETENT SOIL AND/OR STRUCTURAL ENGINEER.

COSHR 111 HORIZONTAL (120K)

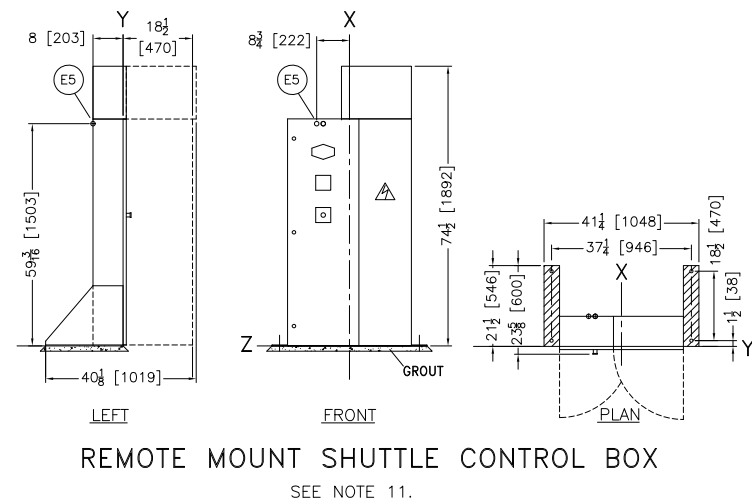
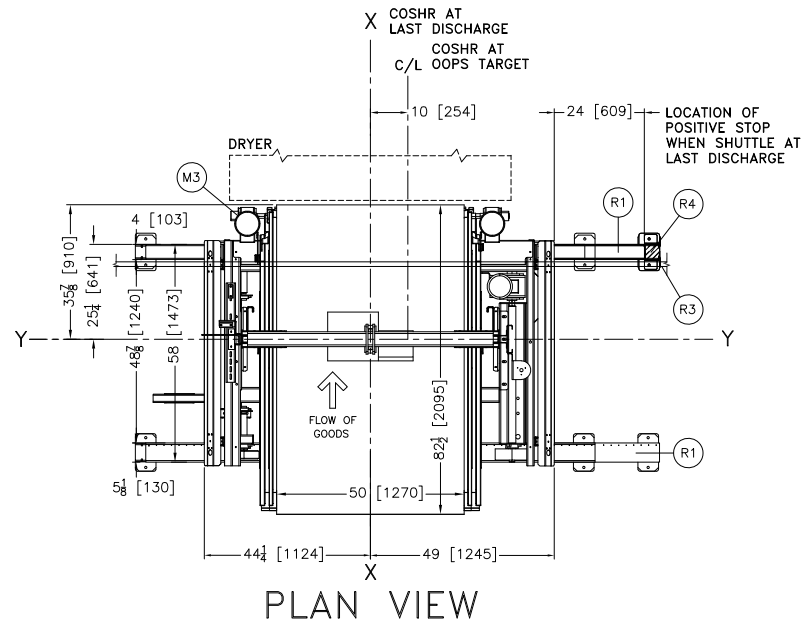
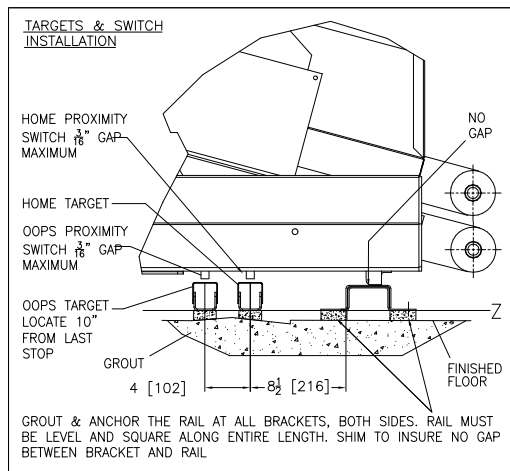
Scale: 0 0.5M / 0 12 24 INCHES

DWG# BDCOSHR1AB 202333D

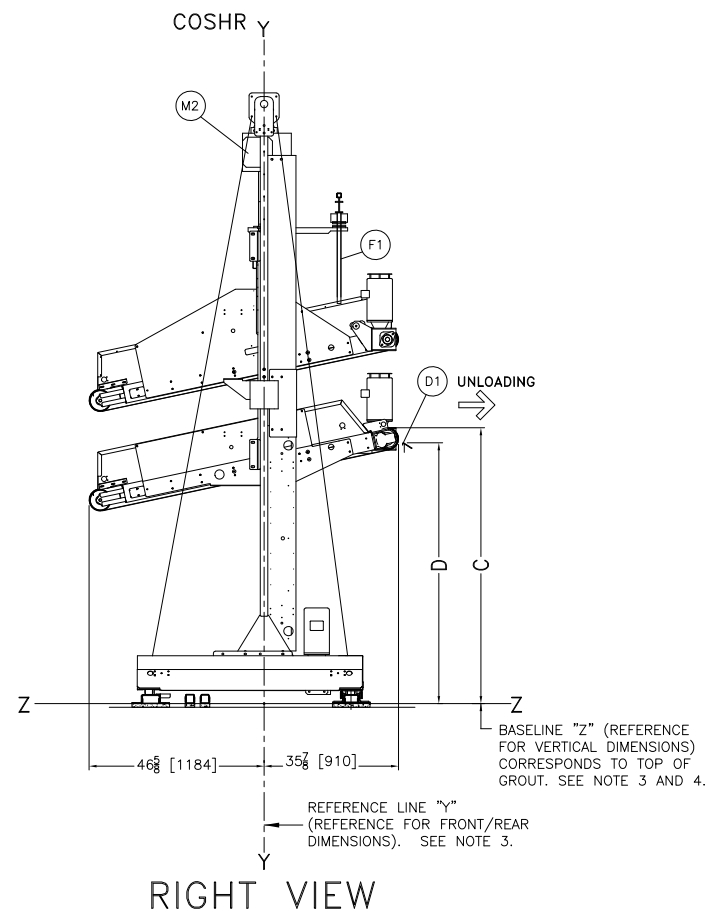
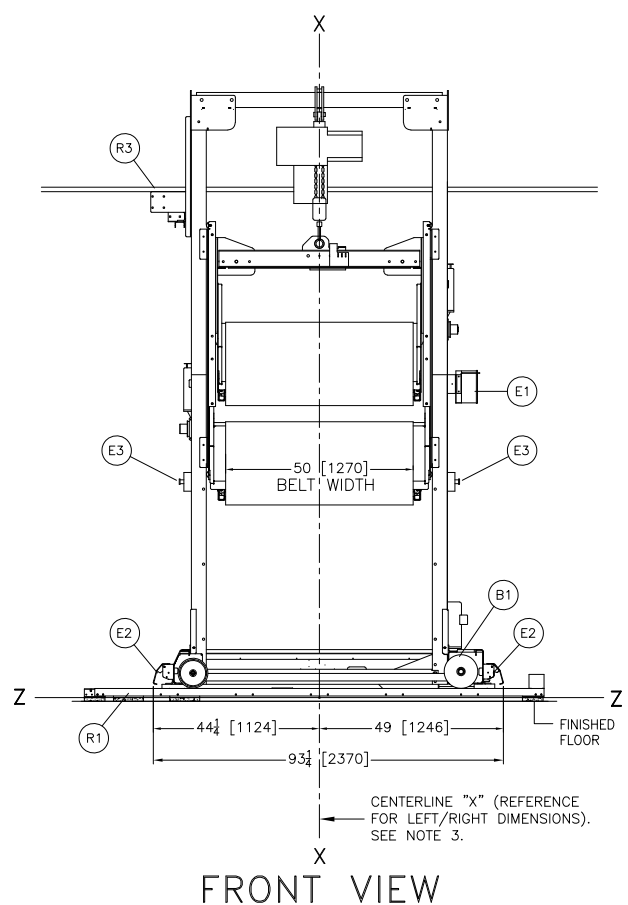
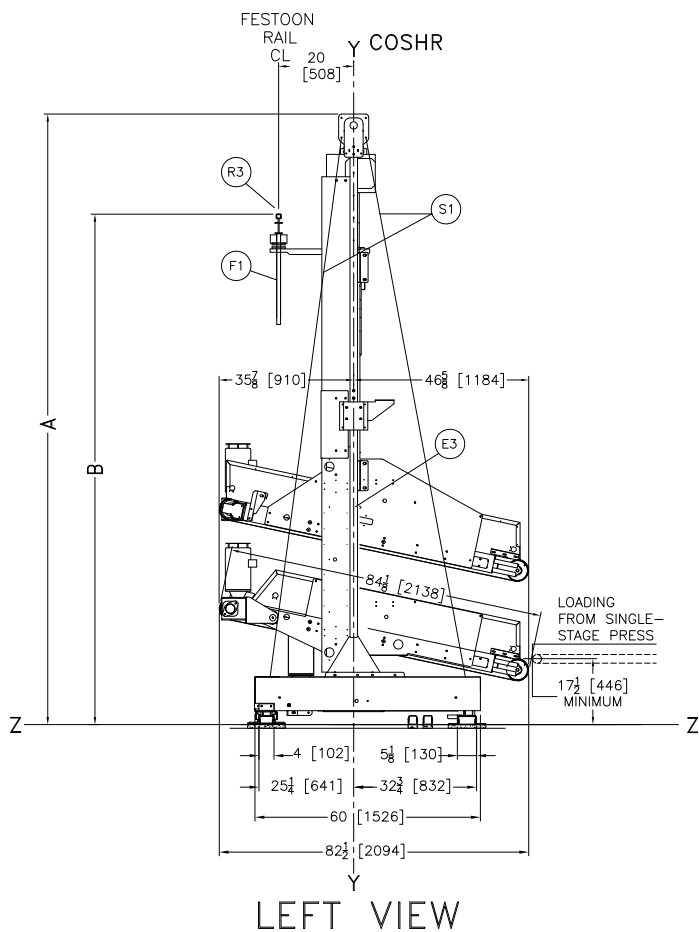
MILNOR PELLERIN MILNOR CORPORATION
 P.O. Box 400 Kenner, LA 70063, USA, Phone 504/467-9591, FAX 504/468-3094, Email: milnorinfo@milnor.com

WHEN THIS DRYER PEDESTAL EXTENDER IS USED WITH DRYER 8282		WHEN THIS DRYER PEDESTAL EXTENDER IS USED WITH DRYER 7676		WHEN THIS DRYER PEDESTAL EXTENDER IS USED WITH DRYER 6458,6464		USE THIS SIDE RAIL EXTENDER COSHR112		COSHR112 DIMENSIONS								DIMENSION "D" 6458,6464 LOAD HEIGHT		DIMENSION "D" 7676,8282 LOAD HEIGHT			
INCHES	mm	INCHES	mm	INCHES	mm	INCHES	mm	DIMENSION "A"		DIMENSION "B" WITH 6458,6464		DIMENSION "B" WITH 7676		DIMENSION "C" WITH 6458,6464		DIMENSION "C" WITH 7676,8282		INCHES	mm	INCHES	mm
		-7	-178	0	0	65 1/2	1664	159 1/2	4051	132 1/2	3366	135 1/2	3442	71	1803	73 1/2	1867	68 1/2	1740		
		-3 1/2	-89	3 1/2	89	69	1752	163	4140	136	3454	139	3531	74 1/2	1892	76 1/2	1943	72	1829	69 1/2	1765
		0	0	7	178	72 1/2	1841	166 1/2	4229	139 1/2	3543	142 1/2	3619	78	1981	76 1/2	1918	75 1/2	1918	73	1854
0	0	3 1/2	89	10 1/2	267	76	1930	170	4318	143	3632	146	3708	81 1/2	2070	80 1/2	2045	79	2007	76 1/2	1943
3 1/2	89	7	178	14	356	79 1/2	2019	173 1/2	4410	146 1/2	3721	149 1/2	3797	85	2159	84	2134	82 1/2	2096	80	2032
10 1/2	267	14	356	17 1/2	444	83	2108	177	4496	150	3810	153	3886	88 1/2	2248	87 1/2	2226	86	2184	83 1/2	2121
17 1/2	445	21	533	24 1/2	622	90	2286	184	4674	157	3988	160	4064	95 1/2	2426	94 1/2	2400	93	2334	90 1/2	2299
				31 1/2	800	97	2464	191	4851	164	4166	167	4242	102 1/2	2604	101 1/2	2578	100	2540	97 1/2	2476

* FOR HIGHER PEDESTALS, CONSULT FACTORY.



ITEM	LEGEND
S1	TIE RODS, SUPPLIED ONLY FOR SHUTTLES WITH 48" [1624] EXTENDERS OR LONGER.
R4	POSITIVE STOP
R3	FESTOON RAIL. RAIL SUPPLIED BY MILNOR AND MAY BE PRICED SEPARATELY. SEE PRICE LIST.
R1	FLOOR DRIVE RAILS. RAIL SUPPLIED BY MILNOR AND MAY BE PRICED SEPARATELY. SEE PRICE LIST.
M3	HOIST MOTOR AND WINCH.
M2	BELT MOTORS, ALTERNATES LEFT/RIGHT PER LEVEL.
M1	DRIVE MOTOR, UNDER CART FRAME, NOT VISIBLE.
F1	FESTOON CABLE
E5	ELECTRICAL & CONTROL CABLE CONNECTIONS FOR REMOTE SHUTTLE CONTROL BOX
E3	EMERGENCY STOP BUTTON
E2	EMERGENCY STOP KICK PLATE
E1	JUNCTION BOX
D1	LOAD DOOR SHELF
B1	CART FRAME WELDMENT



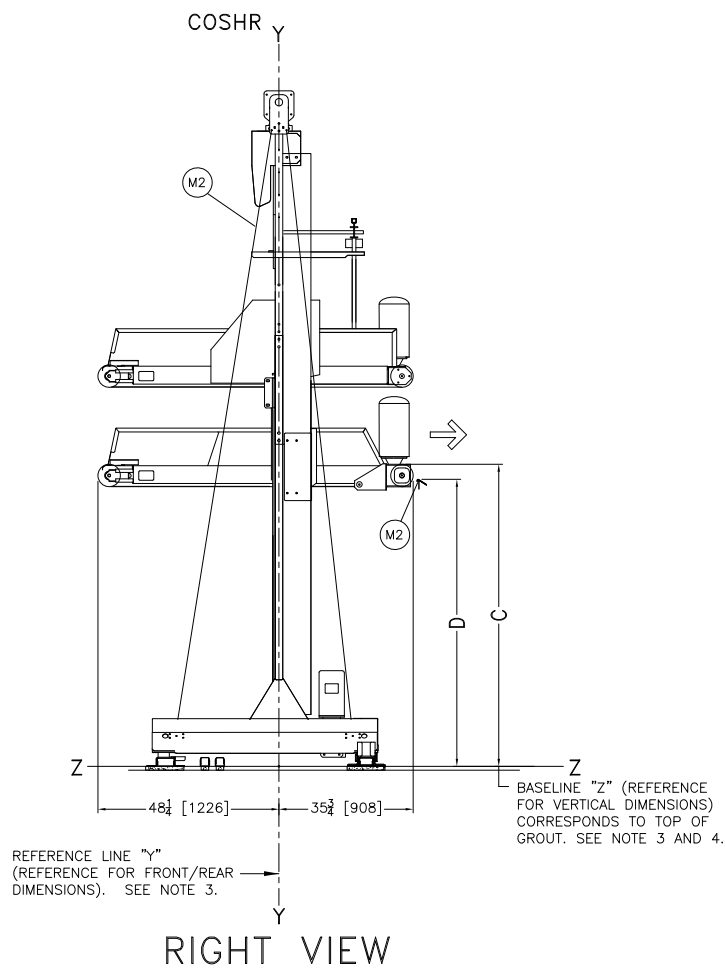
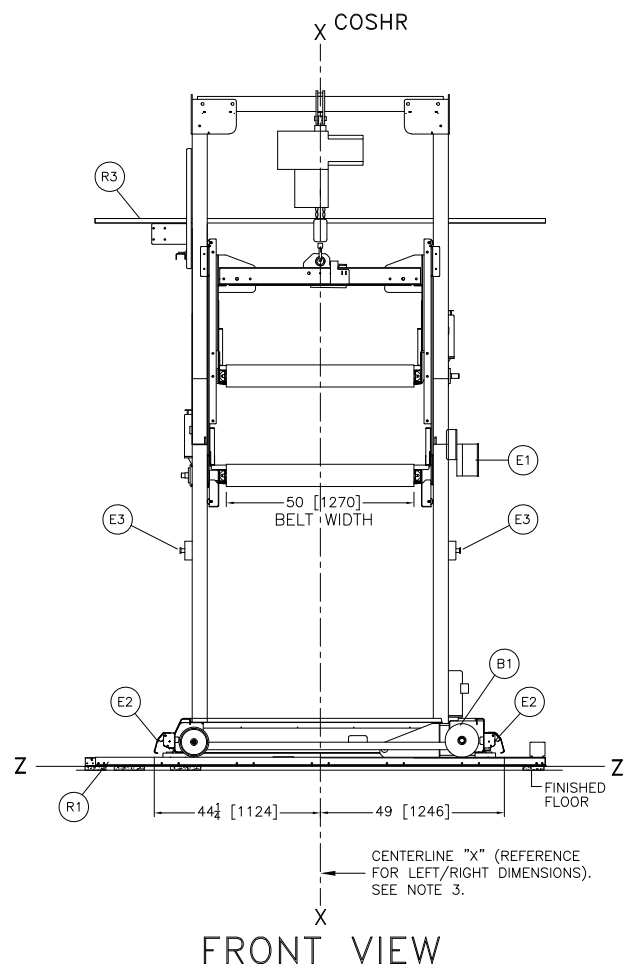
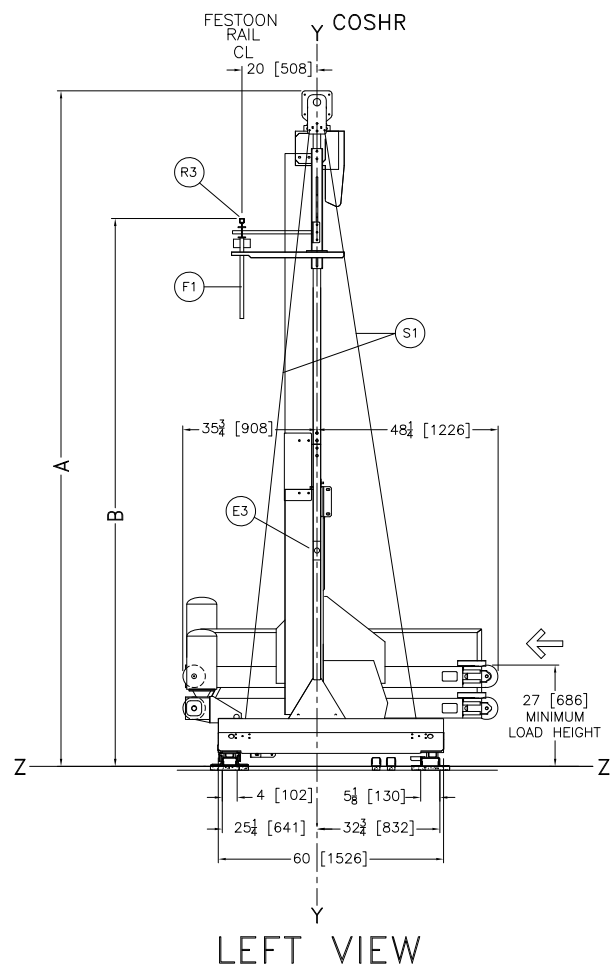
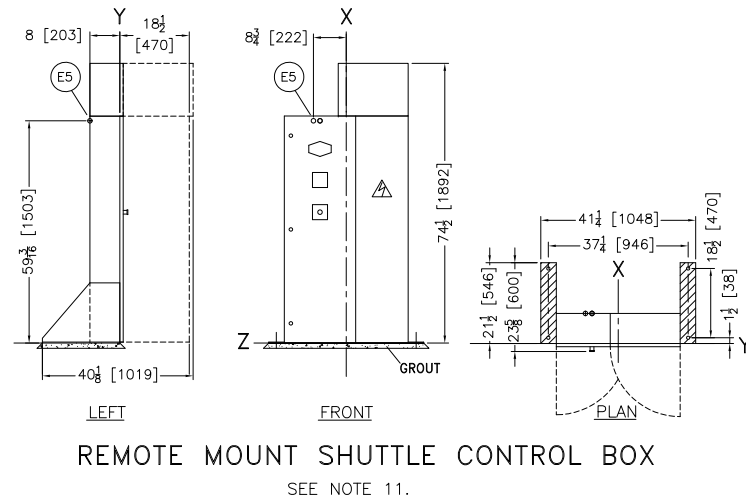
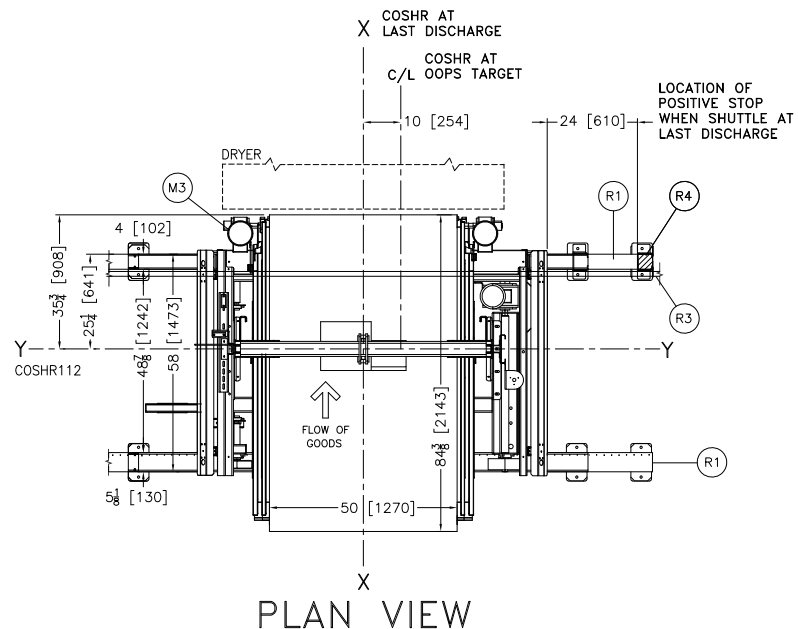
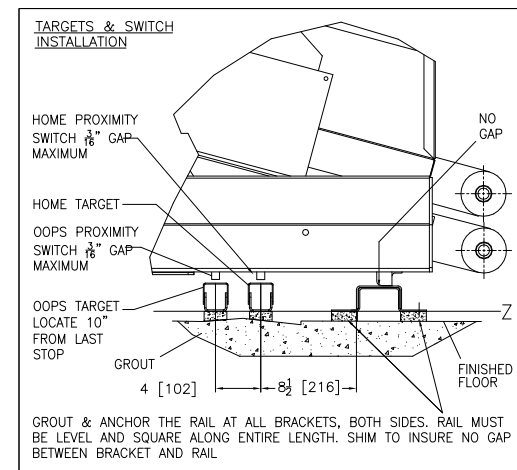
- NOTES**
- FOR THE DIMENSION FROM "Y" OF THE SHUTTLE TO "Y" OF THE DRYER. SEE DRYER DIMENSIONAL DRAWING.
 - THE 6458 DRYER AT "ZERO PEDESTAL" HAS A 41" [1041] HIGH BASE. THE DRYER MAY BE ORDERED TO INCREASE OR DECREASE THE MACHINE HEIGHT. THEREFORE, NEGATIVE PEDESTAL HEIGHTS ARE POSSIBLE. CONSULT MILNOR FACTORY.
 - CONTROLS FOR THE COSHR SHUTTLE ARE CONTAINED IN THIS REMOTELY MOUNTED SHUTTLE CONTROL BOX WHICH MUST BE PLACED IN THE EQUIPMENT LAYOUT.
 - DIMENSION VARIES WITH HEIGHT OF EXTENDERS WHEN ADDED.
 - EMERGENCY STOPS ARE REQUIRED ON BOTH LEFT AND RIGHT SIDES OF THE SHUTTLE. A THIRD EMERGENCY STOP IS INSTALLED INTO THE DOOR OF THE REMOTE SHUTTLE CONTROL BOX.
 - AFTER MACHINE HAS BEEN COMMISSIONED, BELT MAY STRETCH SLIGHTLY REQUIRING ADJUSTMENT OF BELT ROLLERS AND SLIGHT LENGTHENING OF CONVEYOR.
 - AS OF THIS WRITING, THE MINIMUM CLEARANCE REQUIRED BY U.S. NATIONAL ELECTRIC CODES, FROM ELECTRIC BOX TO ANY OBJECT IS:
 - 36 [914] IF OBJECT IS AN UNGROUNDED (INSULATED) WALL.
 - 42 [1067] IF OBJECT IS A GROUNDED WALL (i.e. BARE CONCRETE, BRICK, ETC.)
 - 48 [1219] IF OBJECT IS ANY LIVE PART.
 CHECK LOCAL ELECTRIC CODES FOR FURTHER RESTRICTIONS.
 - CUSTOMER TO SUPPLY CIRCUIT BREAKER OR FUSED BRANCH CIRCUIT DISCONNECT (SAFETY) SWITCHES WITH LAG TYPE FUSES FROM POWER SOURCE TO MACHINE. A SEPARATE GROUND WIRE MUST BE CONNECTED FROM DISCONNECT TO EQUIPMENT.
 - BASELINE "Z" IS THE SAME FOR ALL MILNOR MACHINES AND IS SHOWN ON ALL DIMENSIONAL DRAWINGS. THE DISTANCE BETWEEN BASELINE "Z" AND THE FINISHED FLOOR MAY VARY (WITH CHANGES IN FLOOR HEIGHT) AS REQUIRED TO INSURE THAT BASELINE "Z" IS HORIZONTAL AND ALL COMPONENTS REQUIRING GROUT ARE SET ON A MINIMUM 1" [25] THICK GROUT BED.
 - USE REFERENCE LINES "X", "Y", AND "Z" TO LOCATE ALL SERVICE CONNECTIONS.
 - NUMBERS IN BRACKETS [] DENOTE DIMENSIONS IN MILLIMETERS.
 - ALL DIMENSIONS SHOWN ARE APPROXIMATE, SUBJECT TO NORMAL MANUFACTURING TOLERANCES, AND TO OCCASIONAL CHANGES WITHOUT NOTICE THROUGH REDESIGN AND/OR RELOCATION OF COMPONENTS, ETC. DO NOT USE FOR CONSTRUCTION UNLESS CERTIFIED, AND IN NO EVENT PRE-PIPE CLOSER THAN FIVE FEET FROM MACHINE. FACTORY MUST BE CONSULTED FOR DIMENSIONS IF MACHINE IS TO BE MOVED THROUGH NARROW OR LOW CORRIDORS OR OPENINGS.
- ATTENTION**
- MOST REGULATORY AUTHORITIES (INCLUDING OSHA IN THE USA) HOLD THE OWNER/USER ULTIMATELY RESPONSIBLE TO MAINTAIN A SAFE WORKING ENVIRONMENT. ACCORDINGLY, THE OWNER/USER MUST RECOGNIZE ALL FORESEEABLE SAFETY HAZARDS, FURNISH SAFETY INSTRUCTIONS AND GUIDANCE TO ALL PERSONNEL WHO MAY COME IN CONTACT WITH THE INSTALLATION, AND PROVIDE ALL NECESSARY ADDITIONAL SAFETY GUARDS, FENCES, RESTRAINTS, DEVICES, ETC., NOT FURNISHED BY THE EQUIPMENT MANUFACTURER OR VENDOR.
- ATTENTION**
- THE FLOOR AND/OR OTHER SUPPORT COMPONENTS MUST HAVE SUFFICIENT STRENGTH (AND RIGIDITY WITH DUE CONSIDERATION FOR NATURAL OR RESONANT FREQUENCY THEREOF) TO WITHSTAND THE FULLY LOADED WEIGHT OF THE MACHINE INCLUDING THE GOODS, THE WATER, AND ANY REPEATED SINUSOIDAL (ROTATING) FORCES GENERATED DURING ITS OPERATION. WRITE THE FACTORY FOR ADDITIONAL MACHINE DATA FOR USE BY A COMPETENT SOIL AND/OR STRUCTURAL ENGINEER.

COSHR112 (120K CAKES)

DWG# BDCOSHR2AE
 2023333D
MILNOR PELLERIN MILNOR CORPORATION
 P.O. Box 400 Kenner, LA 70063, USA, Phone 504/467-9591,
 FAX 504/468-3094, Email: milnorinfo@milnor.com

WHEN THIS DRYER PEDESTAL EXTENDER IS USED WITH DRYER 8282		WHEN THIS DRYER PEDESTAL EXTENDER IS USED WITH DRYER 7676		WHEN THIS DRYER PEDESTAL EXTENDER IS USED WITH DRYER 6458,6464		USE THIS SIDE RAIL EXTENDER COSHR112		COSHR112 HORIZONTAL BEDS								DIMENSION "D" 6458,6464 LOAD HEIGHT		DIMENSION "D" 7676,8282 LOAD HEIGHT			
INCHES	mm	INCHES	mm	INCHES	mm	INCHES	mm	DIMENSION "A"		DIMENSION "B" WITH 6458,6464		DIMENSION "B" WITH 7676		DIMENSION "C" WITH 6458,6464		DIMENSION "C" WITH 7676,8282		INCHES	mm	INCHES	mm
								INCHES	mm	INCHES	mm	INCHES	mm	INCHES	mm	INCHES	mm				
		-7	-178	0	0	72 1/2	1842	166 1/2	4229	132 1/2	3366	135 1/2	3442	71	1803	73 1/2	1867	68 1/2	1740	69 1/2	1765
		-3 1/2	-89	3 1/2	89	76	1930	170	4318	136	3544	139	3531	74 1/2	1892	76 1/2	1943	72	1829	73	1854
		0	0	7	178	79 1/2	2019	173 1/2	4407	139 1/2	3543	142 1/2	3619	78	1981	76 1/2	1943	75 1/2	1918	76 1/2	1943
0	0	3 1/2	89	10 1/2	267	83	2108	177	4496	143	3632	146	3708	81 1/2	2070	80 1/2	2045	79	2007	76 1/2	1943
3 1/2	89	7	178	14	356	86 1/2	2197	180 1/2	4585	146 1/2	3721	149 1/2	3797	85	2159	84	2134	82 1/2	2096	80	2032
10 1/2	267	14	356	17 1/2	444	90	2286	184	4674	150	3810	153	3886	88 1/2	2248	87 1/2	2222	86	2184	83 1/2	2121
17 1/2	445	21	533	24 1/2	622	97	2464	191	4851	157	3988	160	4064	95 1/2	2426	94 1/2	2400	93	2362	90 1/2	2299
				31 1/2	800	104	2642	198	5029	164	4166	167	4242	102 1/2	2604	101 1/2	2578	100	2540	97 1/2	2476

* FOR HIGHER PEDESTALS, CONSULT FACTORY.



ITEM	LEGEND
S1	TIE RODS, SUPPLIED ONLY FOR SHUTTLES WITH 48" [1624] EXTENDERS OR LONGER.
R4	POSITIVE STOP
R3	FESTOON RAIL. RAIL SUPPLIED BY MILNOR AND MAY BE PRICED SEPARATELY. SEE PRICE LIST.
R1	FLOOR DRIVE RAILS. RAIL SUPPLIED BY MILNOR AND MAY BE PRICED SEPARATELY. SEE PRICE LIST.
M3	HOIST MOTOR AND WINCH.
M2	BELT MOTORS, ALTERNATES LEFT/RIGHT PER LEVEL.
M1	DRIVE MOTOR, UNDER CART FRAME, NOT VISIBLE.
F1	FESTOON CABLE
E5	ELECTRICAL & CONTROL CABLE CONNECTIONS FOR REMOTE SHUTTLE CONTROL BOX
E3	EMERGENCY STOP BUTTON
E2	EMERGENCY STOP KICK PLATE
E1	JUNCTION BOX
D1	LOAD DOOR SHELF
B1	CART FRAME WELDMENT

- NOTES**
- FOR THE DIMENSION FROM "Y" OF THE SHUTTLE TO "Y" OF THE DRYER. SEE DRYER DIMENSIONAL DRAWING.
 - THE 6458 DRYER AT "ZERO PEDESTAL" HAS A 41" [1041] HIGH BASE. THE DRYER MAY BE ORDERED TO INCREASE OR DECREASE THE MACHINE HEIGHT. THEREFORE, NEGATIVE PEDESTAL HEIGHTS ARE POSSIBLE. CONSULT MILNOR FACTORY.
 - CONTROLS FOR THE COSHR SHUTTLE ARE CONTAINED IN THIS REMOTELY MOUNTED SHUTTLE CONTROL BOX WHICH MUST BE PLACED IN THE EQUIPMENT LAYOUT.
 - DIMENSION VARIES WITH HEIGHT OF EXTENDERS WHEN ADDED.
 - EMERGENCY STOPS ARE REQUIRED ON BOTH LEFT AND RIGHT SIDES OF THE SHUTTLE. A THIRD EMERGENCY STOP IS INSTALLED INTO THE DOOR OF THE REMOTE SHUTTLE CONTROL BOX.
 - AFTER MACHINE HAS BEEN COMMISSIONED, BELT MAY STRETCH SLIGHTLY REQUIRING ADJUSTMENT OF BELT ROLLERS AND SLIGHT LENGTHENING OF CONVEYOR.
 - AS OF THIS WRITING, THE MINIMUM CLEARANCE REQUIRED BY U.S. NATIONAL ELECTRIC CODES, FROM ELECTRIC BOX TO ANY OBJECT IS:
 - 36 [914] IF OBJECT IS AN UNGROUNDED (INSULATED) WALL.
 - 42 [1067] IF OBJECT IS A GROUNDED WALL (ie. BARE CONCRETE, BRICK, ETC.)
 - 48 [1219] IF OBJECT IS ANY LIVE PART.
 CHECK LOCAL ELECTRIC CODES FOR FURTHER RESTRICTIONS.
 - CUSTOMER TO SUPPLY CIRCUIT BREAKER OR FUSED BRANCH CIRCUIT DISCONNECT (SAFETY) SWITCHES WITH LAG TYPE FUSES FROM POWER SOURCE TO MACHINE. A SEPARATE GROUND WIRE MUST BE CONNECTED FROM DISCONNECT TO EQUIPMENT.
 - BASELINE "Z" IS THE SAME FOR ALL MILNOR MACHINES AND IS SHOWN ON ALL DIMENSIONAL DRAWINGS. THE DISTANCE BETWEEN BASELINE "Z" AND THE FINISHED FLOOR MAY VARY (WITH CHANGES IN FLOOR HEIGHT) AS REQUIRED TO INSURE THAT BASELINE "Z" IS HORIZONTAL AND ALL COMPONENTS REQUIRING GROUT ARE SET ON A MINIMUM 1" [25] THICK GROUT BED.
 - USE REFERENCE LINES "X", "Y", AND "Z" TO LOCATE ALL SERVICE CONNECTIONS.
 - NUMBERS IN BRACKETS [] DENOTE DIMENSIONS IN MILLIMETERS.
 - ALL DIMENSIONS SHOWN ARE APPROXIMATE, SUBJECT TO NORMAL MANUFACTURING TOLERANCES, AND TO OCCASIONAL CHANGES WITHOUT NOTICE THROUGH REDESIGN AND/OR RELOCATION OF COMPONENTS, ETC. DO NOT USE FOR CONSTRUCTION UNLESS CERTIFIED, AND IN NO EVENT PRE-PIPE CLOSER THAN FIVE FEET FROM MACHINE. FACTORY MUST BE CONSULTED FOR DIMENSIONS IF MACHINE IS TO BE MOVED THROUGH NARROW OR LOW CORRIDORS OR OPENINGS.
- ATTENTION**
- MOST REGULATORY AUTHORITIES (INCLUDING OSHA IN THE USA) HOLD THE OWNER/USER ULTIMATELY RESPONSIBLE TO MAINTAIN A SAFE WORKING ENVIRONMENT. ACCORDINGLY, THE OWNER/USER MUST RECOGNIZE ALL FORESEEABLE SAFETY HAZARDS, FURNISH SAFETY INSTRUCTIONS AND GUIDANCE TO ALL PERSONNEL WHO MAY COME IN CONTACT WITH THE INSTALLATION, AND PROVIDE ALL NECESSARY ADDITIONAL SAFETY GUARDS, FENCES, RESTRAINTS, DEVICES, ETC., NOT FURNISHED BY THE EQUIPMENT MANUFACTURER OR VENDOR.
- ATTENTION**
- THE FLOOR AND/OR OTHER SUPPORT COMPONENTS MUST HAVE SUFFICIENT STRENGTH (AND RIGIDITY WITH DUE CONSIDERATION FOR NATURAL OR RESONANT FREQUENCY THEREOF) TO WITHSTAND THE FULLY LOADED WEIGHT OF THE MACHINE INCLUDING THE GOODS, THE WATER, AND ANY REPEATED SINUSOIDAL (ROTATING) FORCES GENERATED DURING ITS OPERATION. WRITE THE FACTORY FOR ADDITIONAL MACHINE DATA FOR USE BY A COMPETENT SOIL AND/OR STRUCTURAL ENGINEER.

COSHR112 HORIZONTAL (120K CAKES)

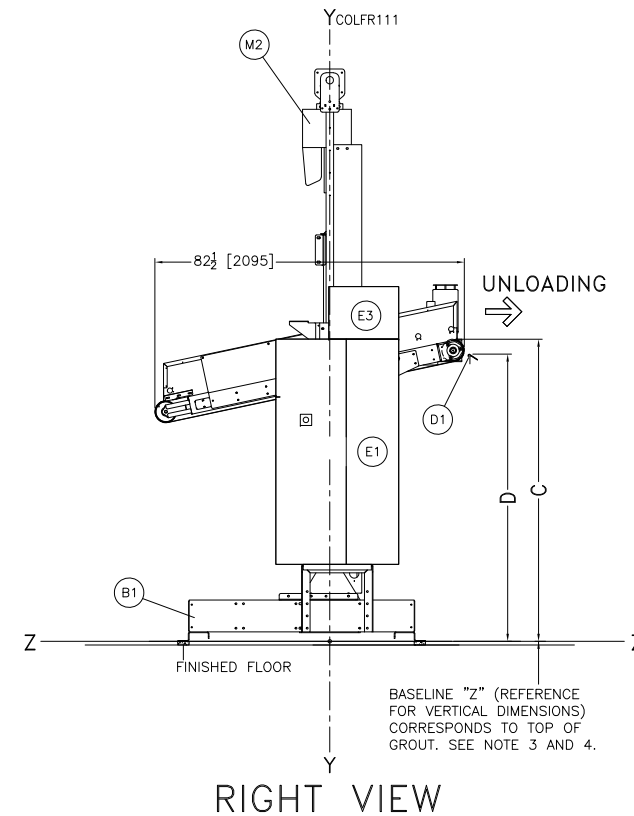
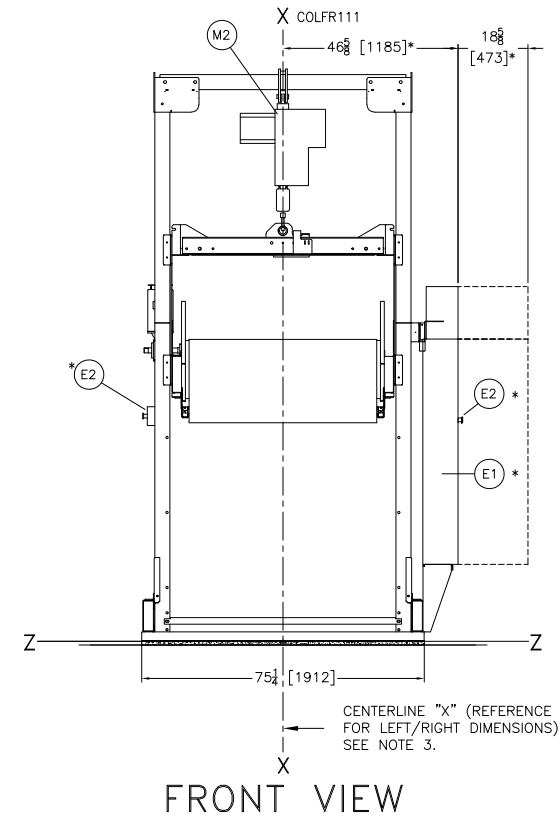
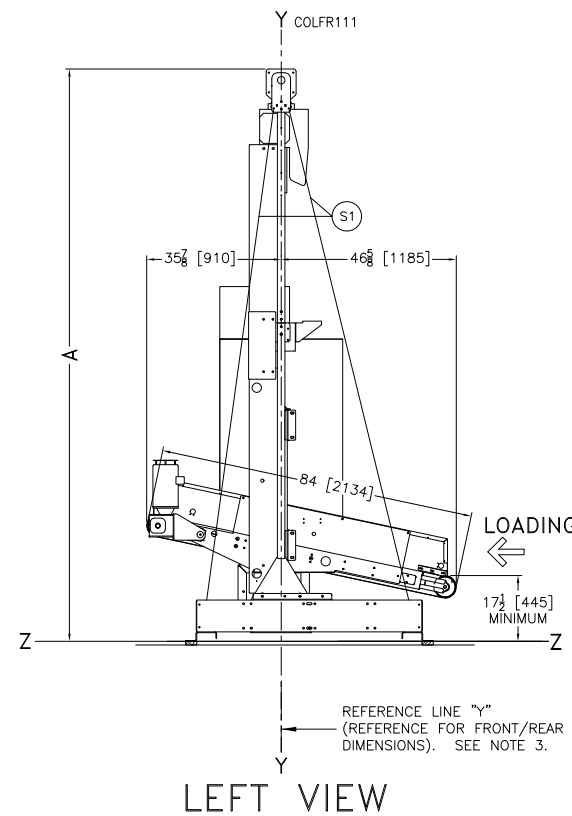
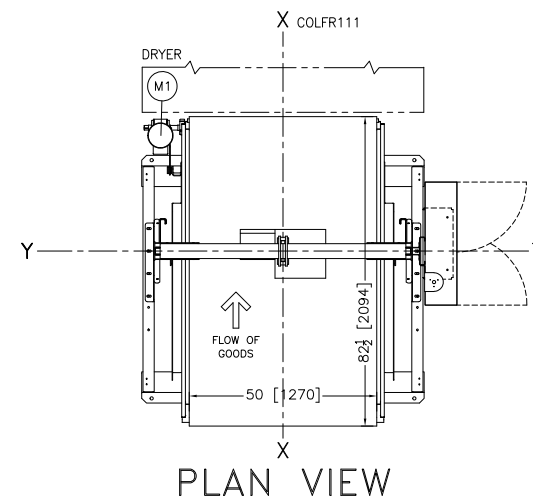
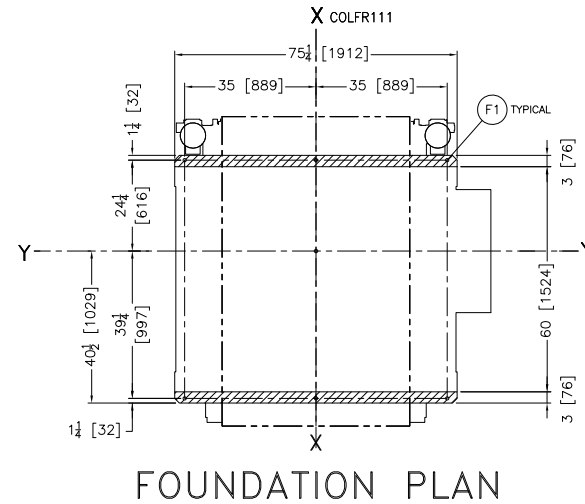
SCALE: 1" = 12"

DWG# BDCOSHR2AB 2023333D

MILNOR PELLERIN MILNOR CORPORATION
P.O. Box 400 Kenner, LA 70063, USA, Phone 504/467-9591, FAX 504/468-3094, Email: milnorinfo@milnor.com

WHEN THIS DRYER PEDESTAL EXTENDER IS USED WITH DRYER 8282		WHEN THIS DRYER PEDESTAL EXTENDER IS USED WITH DRYER 7676		WHEN THIS DRYER PEDESTAL EXTENDER IS USED WITH DRYER 6458,6464		USE THIS SIDE RAIL EXTENDER COLFR111		COLFR111 INCLINED				DIMENSION "D" 6458,6464 LOAD HEIGHT		DIMENSION "D" 7676,8282 LOAD HEIGHT			
INCHES	mm	INCHES	mm	INCHES	mm	INCHES	mm	DIMENSION "A"		DIMENSION "C" WITH 6458,6464		DIMENSION "C" WITH 7676,8282		INCHES	mm	INCHES	mm
								INCHES	mm	INCHES	mm	INCHES	mm				
		-7	-178	0	0	48	1219	142	3780	71	1803	73 1/2	1867	68 1/2	1740	69 1/2	1765
		-3 1/2	-89	3 1/2	89	51 1/2	1308	145 1/2	3696	74 1/2	1892	77	1956	72	1829	73	1854
		0	0	10 1/2	267	58 1/2	1486	152 1/2	3874	81 1/2	2070	80 1/2	2045	79	2007	76 1/2	1943
0	0	3 1/2	89	14	356	62	1575	156	3962	85	2159	84	2134	82 1/2	2096	80	2032
3 1/2	89	7	178	17 1/2	445	65 1/2	1664	159 1/2	4051	88 1/2	2248	87 1/2	2223	86	2184	83 1/2	2121
10 1/2	267	14	356	24 1/2	622	72 1/2	1842	166 1/2	4229	95 1/2	2426	94 1/2	2400	93	2362	90 1/2	2299
17 1/2	445	21	533	31 1/2	800	79 1/2	2019	173 1/2	4407	102 1/2	2604	101 1/2	2578	100	2540	97 1/2	2477

* FOR HIGHER PEDESTALS, CONSULT FACTORY.



ITEM	LEGEND
S1	TIE RODS, SUPPLIED ONLY FOR SHUTTLES WITH 48" [1624] EXTENDERS OR LONGER.
M2	HOIST MOTOR AND WINCH.
M1	BELT MOTORS, ALTERNATES LEFT/RIGHT PER LEVEL.
F1	ANCHOR BOLT HOLE 7/8" [22] DIAMETER, 6 PLACES
E3	MICROPROCESSOR BOX
E2	EMERGENCY STOP BUTTON
E1	CONTROL BOX
D1	LOAD DOOR SHELF, 6458/7272
B1	COELF STAND

NOTES

- THIS DRAWING SHOWS THE COLFR112 WITH CONTROLS RIGHT. THE CONTROLS LEFT MACHINE IS A MIRROR IMAGE. THE ELECTRIC BOX AND DIMENSIONS WITH AN ASTERISK (*) WILL BE ON THE OPPOSITE SIDE.
- THE 6458 DRYER AT "ZERO PEDESTAL" HAS A 41" [1041] HIGH BASE. THE DRYER MAY BE ORDERED TO INCREASE OR DECREASE THE MACHINE HEIGHT. THEREFORE, NEGATIVE PEDESTAL HEIGHTS ARE POSSIBLE. CONSULT MILNOR FACTORY.
- DIMENSION VARIES WITH HEIGHT OF EXTENDERS WHEN ADDED.
- EMERGENCY STOPS ARE REQUIRED ON BOTH LEFT AND RIGHT SIDES OF THE SHUTTLE. A THIRD EMERGENCY STOP IS INSTALLED INTO THE DOOR OF THE REMOTE SHUTTLE CONTROL BOX.
- AFTER MACHINE HAS BEEN COMMISSIONED, BELT MAY STRETCH SLIGHTLY REQUIRING ADJUSTMENT OF BELT ROLLERS AND SLIGHT LENGTHENING OF CONVEYOR.
- AS OF THIS WRITING, THE MINIMUM CLEARANCE REQUIRED BY U.S. NATIONAL ELECTRIC CODES, FROM ELECTRIC BOX TO ANY OBJECT IS:
 - 36 [914] IF OBJECT IS AN UNGROUNDED (INSULATED) WALL.
 - 42 [1067] IF OBJECT IS A GROUNDED WALL (ie. BARE CONCRETE, BRICK, ETC.)
 - 48 [1219] IF OBJECT IS ANY LIVE PART.
 CHECK LOCAL ELECTRIC CODES FOR FURTHER RESTRICTIONS.
- CUSTOMER TO SUPPLY CIRCUIT BREAKER OR FUSED BRANCH CIRCUIT DISCONNECT (SAFETY) SWITCHES WITH LAG TYPE FUSES FROM POWER SOURCE TO MACHINE. A SEPARATE GROUND WIRE MUST BE CONNECTED FROM DISCONNECT TO EQUIPMENT.
- BASELINE "Z" IS THE SAME FOR ALL MILNOR MACHINES AND IS SHOWN ON ALL DIMENSIONAL DRAWINGS. THE DISTANCE BETWEEN BASELINE "Z" AND THE FINISHED FLOOR MAY VARY (WITH CHANGES IN FLOOR HEIGHT) AS REQUIRED TO INSURE THAT BASELINE "Z" IS HORIZONTAL AND ALL COMPONENTS REQUIRING GROUT ARE SET ON A MINIMUM 1" [25] THICK GROUT BED.
- USE REFERENCE LINES "X", "Y", AND "Z" TO LOCATE ALL SERVICE CONNECTIONS.
- NUMBERS IN BRACKETS [] DENOTE DIMENSIONS IN MILLIMETERS.
- ALL DIMENSIONS SHOWN ARE APPROXIMATE, SUBJECT TO NORMAL MANUFACTURING TOLERANCES, AND TO OCCASIONAL CHANGES WITHOUT NOTICE THROUGH REDESIGN AND/OR RELOCATION OF COMPONENTS, ETC. DO NOT USE FOR CONSTRUCTION UNLESS CERTIFIED, AND IN NO EVENT PRE-PIPE CLOSER THAN FIVE FEET FROM MACHINE. FACTORY MUST BE CONSULTED FOR DIMENSIONS IF MACHINE IS TO BE MOVED THROUGH NARROW OR LOW CORRIDORS OR OPENINGS.

ATTENTION

MOST REGULATORY AUTHORITIES (INCLUDING OSHA IN THE USA) HOLD THE OWNER/USER ULTIMATELY RESPONSIBLE TO MAINTAIN A SAFE WORKING ENVIRONMENT. ACCORDINGLY, THE OWNER/USER MUST RECOGNIZE ALL FORESEEABLE SAFETY HAZARDS, FURNISH SAFETY INSTRUCTIONS AND GUIDANCE TO ALL PERSONNEL WHO MAY COME IN CONTACT WITH THE INSTALLATION, AND PROVIDE ALL NECESSARY ADDITIONAL SAFETY GUARDS, FENCES, RESTRAINTS, DEVICES, ETC., NOT FURNISHED BY THE EQUIPMENT MANUFACTURER OR VENDOR.

ATTENTION

THE FLOOR AND/OR OTHER SUPPORT COMPONENTS MUST HAVE SUFFICIENT STRENGTH (AND RIGIDITY WITH DUE CONSIDERATION FOR NATURAL OR RESONANT FREQUENCY THEREOF) TO WITHSTAND THE FULLY LOADED WEIGHT OF THE MACHINE INCLUDING THE GOODS, THE WATER, AND ANY REPEATED SINUSOIDAL (ROTATING) FORCES GENERATED DURING ITS OPERATION. WRITE THE FACTORY FOR ADDITIONAL MACHINE DATA FOR USE BY A COMPETENT SOIL AND/OR STRUCTURAL ENGINEER.

COLFR111 (120K CAKES)

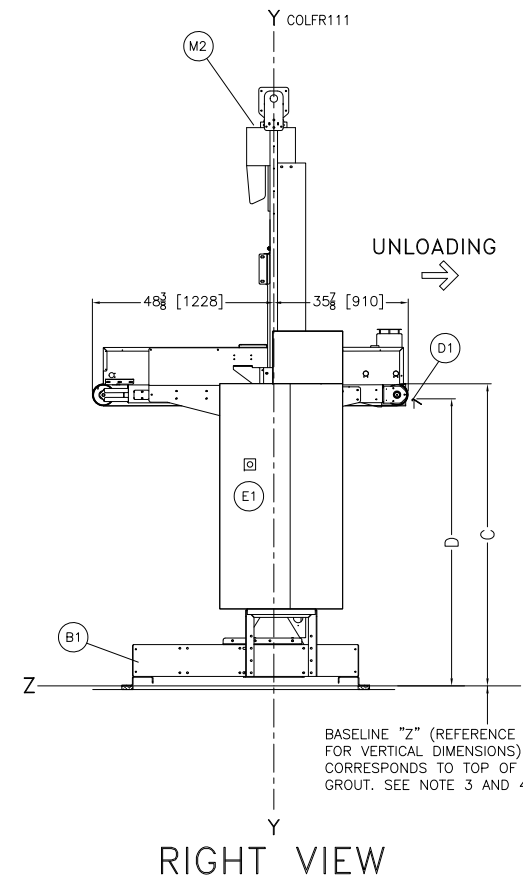
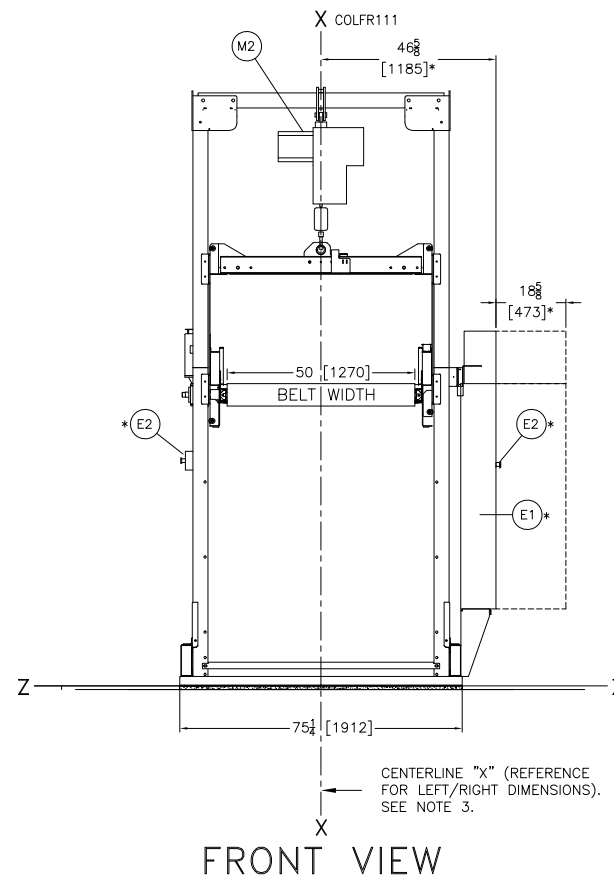
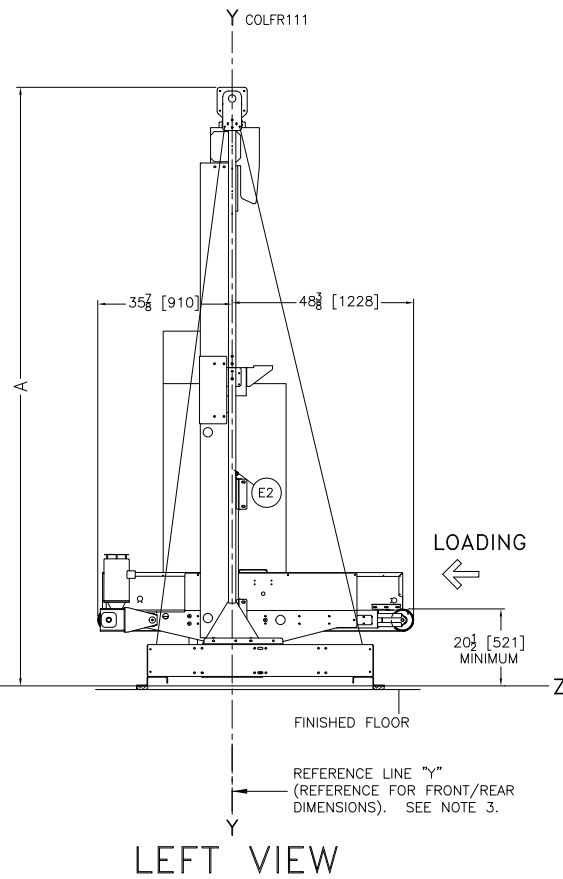
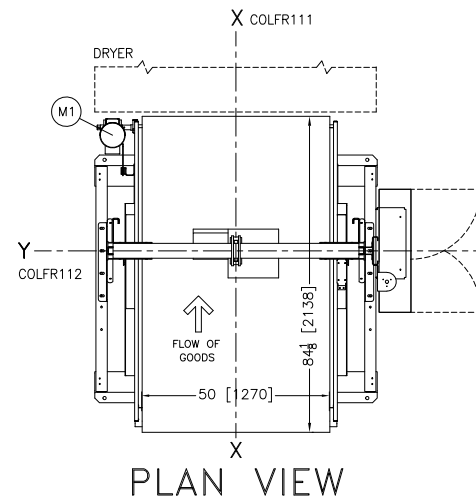
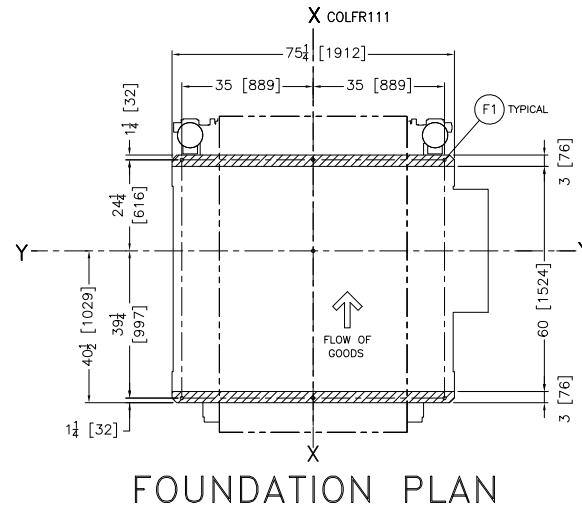
Scale: 0 0.5M / 0 12 24 INCHES

DWG# BDCOLFR1AE 202333D

MILNOR PELLERIN MILNOR CORPORATION
P.O. Box 400 Kenner, LA 70063, USA, Phone 504/467-9591, FAX 504/468-3094, Email: milnorinfo@milnor.com

WHEN THIS DRYER PEDESTAL EXTENDER IS USED WITH DRYER 8282		WHEN THIS DRYER PEDESTAL EXTENDER IS USED WITH DRYER 7676		WHEN THIS DRYER PEDESTAL EXTENDER IS USED WITH DRYER 6458,6464		USE THIS SIDE RAIL EXTENDER COLFR111		COLFR111 HORIZONTAL BEDS				DIMENSION "D" 6458,6464 LOAD HEIGHT		DIMENSION "D" 7676,8282 LOAD HEIGHT			
INCHES	mm	INCHES	mm	INCHES	mm	INCHES	mm	DIMENSION "A"		DIMENSION "C" WITH 6458,6464		DIMENSION "C" WITH 7676,8282		INCHES	mm	INCHES	mm
								INCHES	mm	INCHES	mm	INCHES	mm				
		-7	-178	0	0	55	1397	149	3785	71	1803	73 1/2	1867	68 1/2	1740	69 1/2	1765
		-3 1/2	-89	3 1/2	89	58 1/2	1486	152 1/2	3874	74 1/2	1892	77	1956	72	1829	73	1854
		0	0	7	178	62	1575	156	3962	78	1981	80 1/2	2045	75 1/2	1918	76 1/2	1943
0	0	3 1/2	89	10 1/2	267	65 1/2	1664	159 1/2	4051	81 1/2	2070	80 1/2	2045	79	2007	76 1/2	1943
3 1/2	89	7	178	14	356	69	1753	163	4140	85	2159	84	2134	82 1/2	2096	80	2032
10 1/2	267	14	356	17 1/2	445	72 1/2	1842	166 1/2	4229	88 1/2	2248	87 1/2	2223	86	2184	83 1/2	2121
17 1/2	445	21	533	24 1/2	622	79 1/2	2019	173 1/2	4407	95 1/2	2426	94 1/2	2400	93	2362	90 1/2	2299
				31 1/2	800	86 1/2	2197	180 1/2	4585	102 1/2	2604	101 1/2	2578	100	2540	97 1/2	2477

* FOR HIGHER PEDESTALS, CONSULT FACTORY.



ITEM	LEGEND
S1	TIE RODS, SUPPLIED ONLY FOR SHUTTLES WITH 48" [1624] EXTENDERS OR LONGER.
M2	HOIST MOTOR AND WINCH.
M1	BELT MOTORS, ALTERNATES LEFT/RIGHT PER LEVEL.
F1	ANCHOR BOLT HOLE 7/8" [22] DIAMETER, 6 PLACES
E3	MICROPROCESSOR BOX
E2	EMERGENCY STOP BUTTON
E1	CONTROL BOX
D1	LOAD DOOR SHELF, 6458/7272
B1	COELF STAND

NOTES

- THIS DRAWING SHOWS THE COLFR112 WITH CONTROLS RIGHT. THE CONTROLS LEFT MACHINE IS A MIRROR IMAGE. THE ELECTRIC BOX AND DIMENSIONS WITH AN ASTERISK (*) WILL BE ON THE OPPOSITE SIDE.
- THE 6458 DRYER AT "ZERO PEDESTAL" HAS A 41" [1041] HIGH BASE. THE DRYER MAY BE ORDERED TO INCREASE OR DECREASE THE MACHINE HEIGHT. THEREFORE, NEGATIVE PEDESTAL HEIGHTS ARE POSSIBLE. CONSULT MILNOR FACTORY.
- DIMENSION VARIES WITH HEIGHT OF EXTENDERS WHEN ADDED.
- EMERGENCY STOPS ARE REQUIRED ON BOTH LEFT AND RIGHT SIDES OF THE SHUTTLE. A THIRD EMERGENCY STOP IS INSTALLED INTO THE DOOR OF THE REMOTE SHUTTLE CONTROL BOX.
- AFTER MACHINE HAS BEEN COMMISSIONED, BELT MAY STRETCH SLIGHTLY REQUIRING ADJUSTMENT OF BELT ROLLERS AND SLIGHT LENGTHENING OF CONVEYOR.
- AS OF THIS WRITING, THE MINIMUM CLEARANCE REQUIRED BY U.S. NATIONAL ELECTRIC CODES, FROM ELECTRIC BOX TO ANY OBJECT IS:
 - 36 [914] IF OBJECT IS AN UNGROUNDED (INSULATED) WALL.
 - 42 [1067] IF OBJECT IS A GROUNDED WALL (ie. BARE CONCRETE, BRICK, ETC.)
 - 48 [1219] IF OBJECT IS ANY LIVE PART.
 CHECK LOCAL ELECTRIC CODES FOR FURTHER RESTRICTIONS.
- CUSTOMER TO SUPPLY CIRCUIT BREAKER OR FUSED BRANCH CIRCUIT DISCONNECT (SAFETY) SWITCHES WITH LAG TYPE FUSES FROM POWER SOURCE TO MACHINE. A SEPARATE GROUND WIRE MUST BE CONNECTED FROM DISCONNECT TO EQUIPMENT.
- BASELINE "Z" IS THE SAME FOR ALL MILNOR MACHINES AND IS SHOWN ON ALL DIMENSIONAL DRAWINGS. THE DISTANCE BETWEEN BASELINE "Z" AND THE FINISHED FLOOR MAY VARY (WITH CHANGES IN FLOOR HEIGHT) AS REQUIRED TO INSURE THAT BASELINE "Z" IS HORIZONTAL AND ALL COMPONENTS REQUIRING GROUT ARE SET ON A MINIMUM 1" [25] THICK GROUT BED.
- USE REFERENCE LINES "X", "Y", AND "Z" TO LOCATE ALL SERVICE CONNECTIONS.
- NUMBERS IN BRACKETS [] DENOTE DIMENSIONS IN MILLIMETERS.
- ALL DIMENSIONS SHOWN ARE APPROXIMATE, SUBJECT TO NORMAL MANUFACTURING TOLERANCES, AND TO OCCASIONAL CHANGES WITHOUT NOTICE THROUGH REDESIGN AND/OR RELOCATION OF COMPONENTS, ETC. DO NOT USE FOR CONSTRUCTION UNLESS CERTIFIED, AND IN NO EVENT PRE-PIPE CLOSER THAN FIVE FEET FROM MACHINE. FACTORY MUST BE CONSULTED FOR DIMENSIONS IF MACHINE IS TO BE MOVED THROUGH NARROW OR LOW CORRIDORS OR OPENINGS.

ATTENTION

MOST REGULATORY AUTHORITIES (INCLUDING OSHA IN THE USA) HOLD THE OWNER/USER ULTIMATELY RESPONSIBLE TO MAINTAIN A SAFE WORKING ENVIRONMENT. ACCORDINGLY, THE OWNER/USER MUST RECOGNIZE ALL FORESEEABLE SAFETY HAZARDS, FURNISH SAFETY INSTRUCTIONS AND GUIDANCE TO ALL PERSONNEL WHO MAY COME IN CONTACT WITH THE INSTALLATION, AND PROVIDE ALL NECESSARY ADDITIONAL SAFETY GUARDS, FENCES, RESTRAINTS, DEVICES, ETC., NOT FURNISHED BY THE EQUIPMENT MANUFACTURER OR VENDOR.

ATTENTION

THE FLOOR AND/OR OTHER SUPPORT COMPONENTS MUST HAVE SUFFICIENT STRENGTH (AND RIGIDITY WITH DUE CONSIDERATION FOR NATURAL OR RESONANT FREQUENCY THEREOF) TO WITHSTAND THE FULLY LOADED WEIGHT OF THE MACHINE INCLUDING THE GOODS, THE WATER, AND ANY REPEATED SINUSOIDAL (ROTATING) FORCES GENERATED DURING ITS OPERATION. WRITE THE FACTORY FOR ADDITIONAL SAFETY DATA FOR USE BY A COMPETENT SOIL AND/OR STRUCTURAL ENGINEER.

COLFR111 (120K CAKES) HORIZONTAL

DM 0 0.5M
INCHES 0 12 24

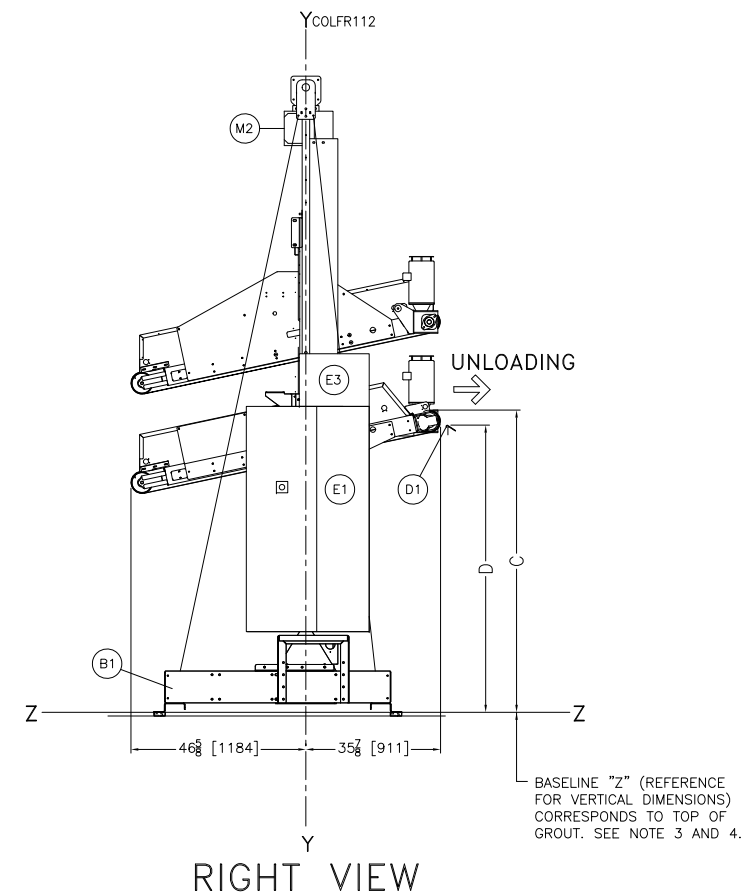
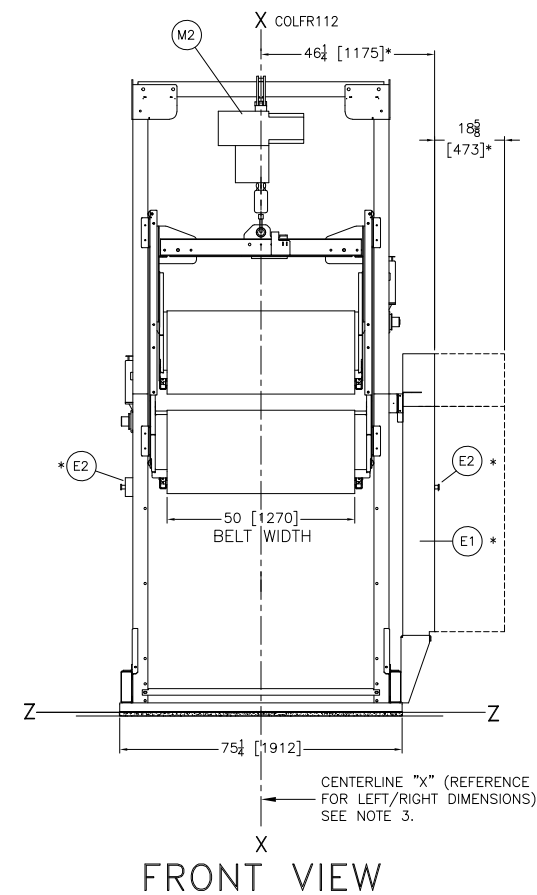
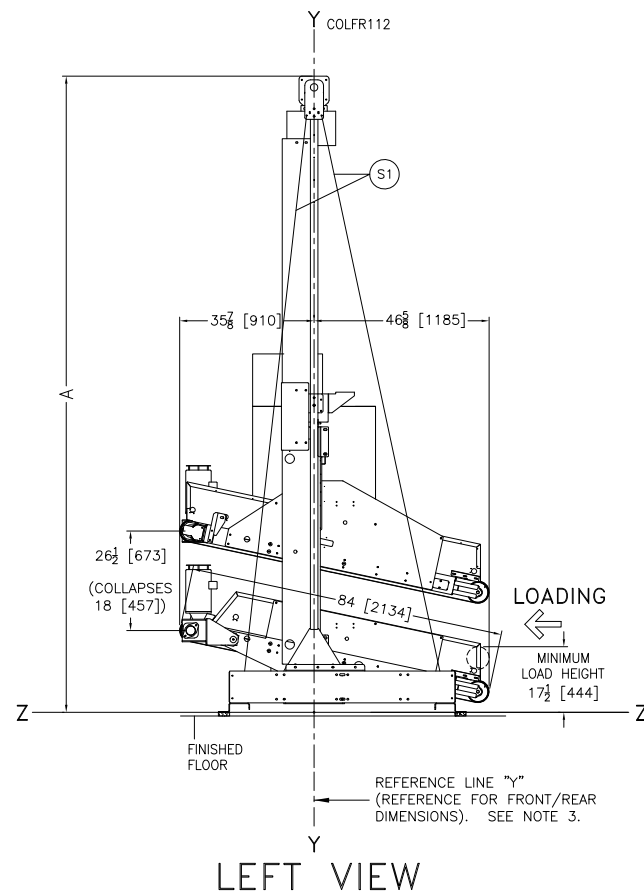
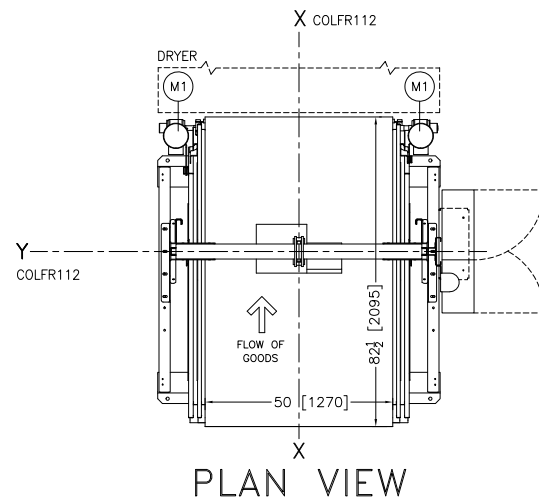
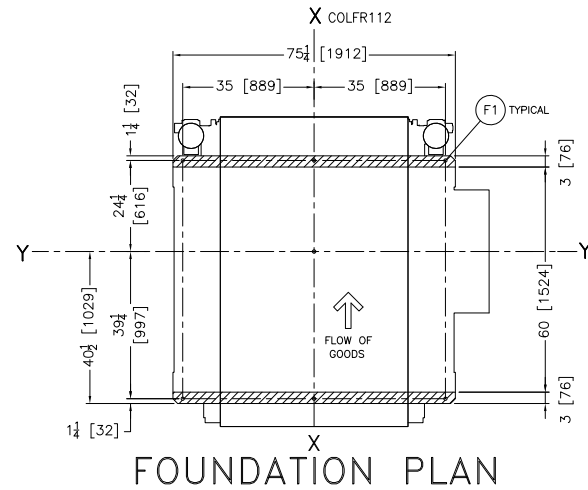
DWG# BDCOLFR1AB
2023333D

MILNOR PELLERIN MILNOR CORPORATION
P.O. Box 400 Kenner, LA 70063, USA, Phone 504/467-9591,
FAX 504/468-3094, Email: milnorinfo@milnor.com

* FOR HIGHER PEDESTALS, CONSULT FACTORY.

WHEN THIS DRYER PEDESTAL EXTENDER IS USED WITH DRYER 8282		WHEN THIS DRYER PEDESTAL EXTENDER IS USED WITH DRYER 7676		WHEN THIS DRYER PEDESTAL EXTENDER IS USED WITH DRYER 6458,6464		USE THIS SIDE RAIL EXTENDER COLFR112		COLFR112 DIMENSIONS				DIMENSION "D" 6458,6464 LOAD HEIGHT		DIMENSION "D" 7676,8282 LOAD HEIGHT			
INCHES	mm	INCHES	mm	INCHES	mm	INCHES	mm	DIMENSION "A"		DIMENSION "C" WITH 6458,6464		DIMENSION "C" WITH 7676,8282		INCHES	mm	INCHES	mm
								INCHES	mm	INCHES	mm	INCHES	mm	INCHES	mm	INCHES	mm
		-7	-178	0	0	65 1/2	1664	159 1/2	4051	71	1803	73 1/2	1867	68 1/2	1740	69 1/2	1765
		-3 1/2	-89	3 1/2	89	69	1752	163	4140	74 1/2	1892	76 1/2	1943	72	1829	73	1854
		0	0	7	178	72 1/2	1841	166 1/2	4229	78	1981	76 1/2	1943	75 1/2	1918	76 1/2	1943
0	0	3 1/2	89	10 1/2	267	76	1930	170	4318	81 1/2	2070	80 1/2	2045	79	2007	76 1/2	1943
3 1/2	89	7	178	14	356	79 1/2	2019	173 1/2	4410	85	2159	84	2134	82 1/2	2096	80	2032
10 1/2	267	14	356	21	533	86 1/2	2197	180 1/2	4585	92	2337	87 1/2	2226	89 1/2	2273	83 1/2	2121
17 1/2	445	21	533	28	711	93 1/2	2375	187 1/2	4762	99	2515	94 1/2	2400	96 1/2	2451	90 1/2	2299
				35	889	100 1/2	2553	194 1/2	4940	106	2692	101 1/2	2578	103 1/2	2629	97 1/2	2476

* FOR HIGHER PEDESTALS, CONSULT FACTORY.



ITEM	LEGEND
S1	TIE RODS, SUPPLIED ONLY FOR SHUTTLES WITH 48" [1624] EXTENDERS OR LONGER.
M3	HOIST MOTOR AND WINCH.
M2	BELT MOTORS, ALTERNATES LEFT/RIGHT PER LEVEL.
M1	DRIVE MOTOR, UNDER CART FRAME, NOT VISIBLE.
F1	ANCHOR BOLT HOLE 7/8" [22] DIAMETER, 6 PLACES
E3	EMERGENCY STOP BUTTON
E2	CONTROL BOX
E1	MICROPROCESSOR BOX
D1	DRYER LOAD SHELF
B1	COLF STAND

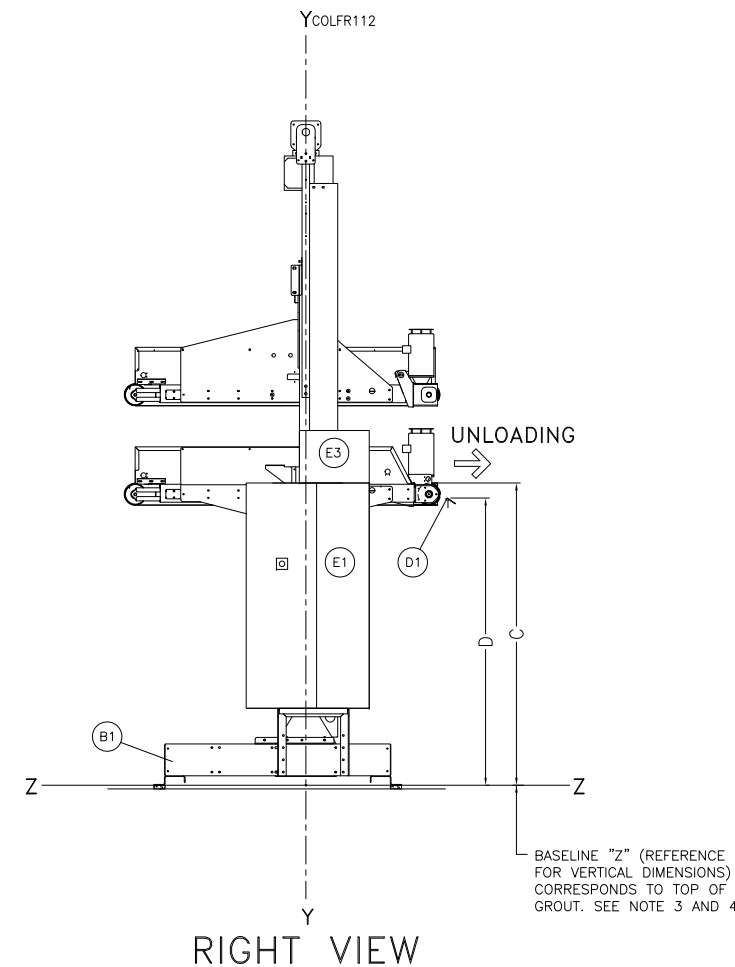
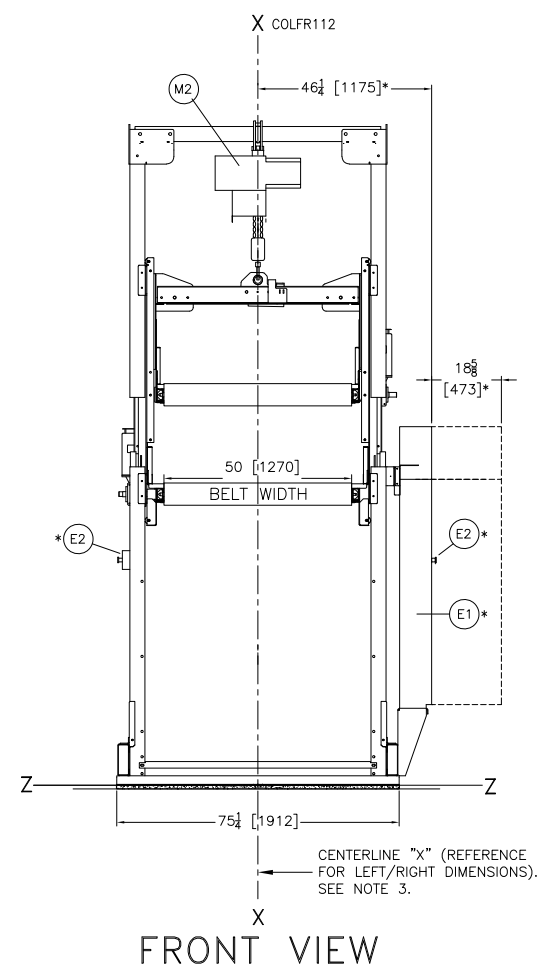
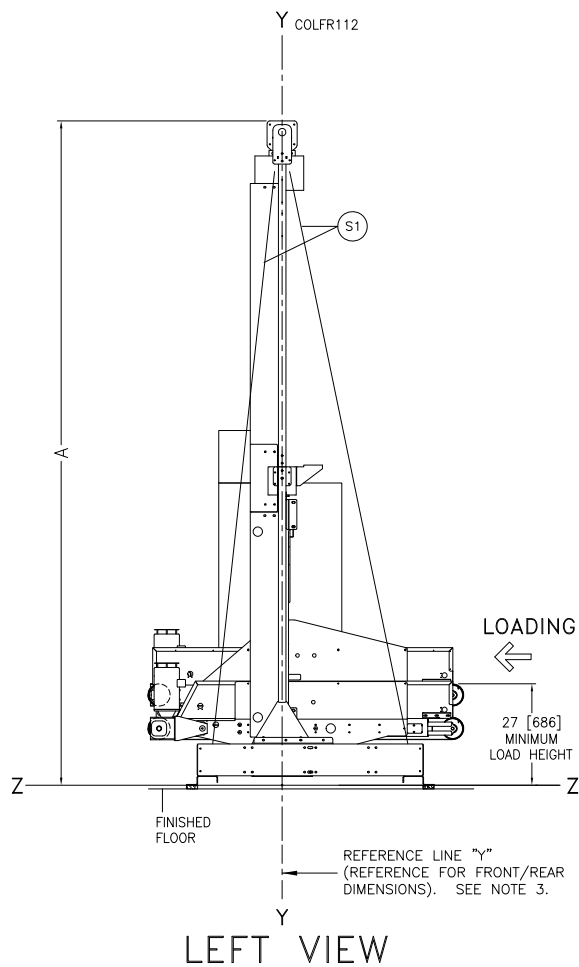
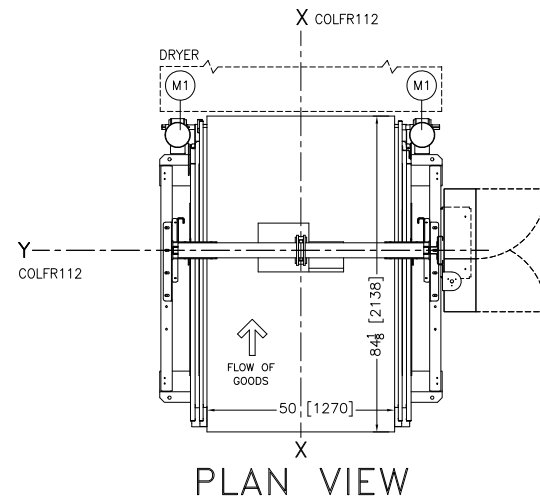
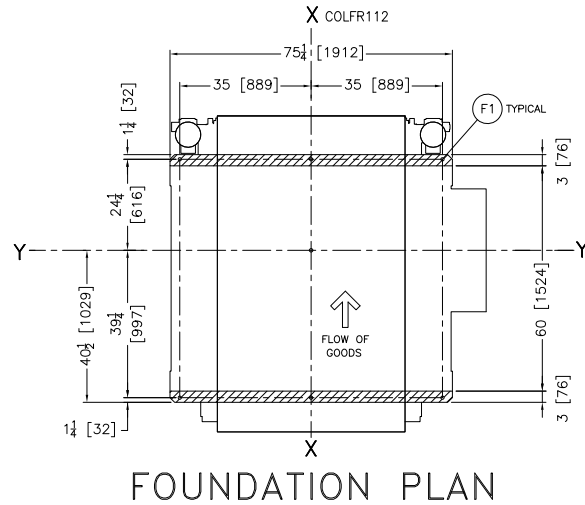
- NOTES**
- FOR THE DIMENSION FROM "Y" OF THE SHUTTLE TO "Y" OF THE DRYER, SEE THE DRYER DIMENSIONAL DRAWING.
 - THE 6458 DRYER AT "ZERO PEDESTAL" HAS A 41" [1041] HIGH BASE. THE DRYER MAY BE ORDERED TO INCREASE OR DECREASE THE MACHINE HEIGHT, THEREFORE, NEGATIVE PEDESTAL HEIGHTS ARE POSSIBLE. CONSULT MILNOR FACTORY.
 - DIMENSION VARIES WITH HEIGHT OF EXTENDERS WHEN ADDED.
 - EMERGENCY STOPS ARE REQUIRED ON BOTH LEFT AND RIGHT SIDES OF THE COLF. ONE IS INSTALLED INTO THE DOOR OF THE COLF CONTROL BOX.
 - AFTER MACHINE HAS BEEN COMMISSIONED, BELT MAY STRETCH SLIGHTLY REQUIRING ADJUSTMENT OF BELT ROLLERS AND SLIGHT LENGTHENING OF CONVEYOR.
 - AS OF THIS WRITING, THE MINIMUM CLEARANCE REQUIRED BY U.S. NATIONAL ELECTRIC CODES, FROM ELECTRIC BOX TO ANY OBJECT IS:
 - 36 [914] IF OBJECT IS AN UNGROUNDED (INSULATED) WALL.
 - 42 [1067] IF OBJECT IS A GROUNDED WALL (ie. BARE CONCRETE, BRICK, ETC.)
 - 48 [1219] IF OBJECT IS ANY LIVE PART.
 CHECK LOCAL ELECTRIC CODES FOR FURTHER RESTRICTIONS.
 - CUSTOMER TO SUPPLY CIRCUIT BREAKER OR FUSED BRANCH CIRCUIT DISCONNECT (SAFETY) SWITCHES WITH LAG TYPE FUSES FROM POWER SOURCE TO MACHINE. A SEPARATE GROUND WIRE MUST BE CONNECTED FROM DISCONNECT TO EQUIPMENT.
 - BASELINE "Z" IS THE SAME FOR ALL MILNOR MACHINES AND IS SHOWN ON ALL DIMENSIONAL DRAWINGS. THE DISTANCE BETWEEN BASELINE "Z" AND THE FINISHED FLOOR MAY VARY (WITH CHANGES IN FLOOR HEIGHT) AS REQUIRED TO INSURE THAT BASELINE "Z" IS HORIZONTAL AND ALL COMPONENTS REQUIRING GROUT ARE SET ON A MINIMUM 1" [25] THICK GROUT BED.
 - USE REFERENCE LINES "X", "Y", AND "Z" TO LOCATE ALL SERVICE CONNECTIONS.
 - NUMBERS IN BRACKETS [] DENOTE DIMENSIONS IN MILLIMETERS.
 - ALL DIMENSIONS SHOWN ARE APPROXIMATE, SUBJECT TO NORMAL MANUFACTURING TOLERANCES, AND TO OCCASIONAL CHANGES WITHOUT NOTICE THROUGH REDESIGN AND/OR RELOCATION OF COMPONENTS, ETC. DO NOT USE FOR CONSTRUCTION UNLESS CERTIFIED, AND IN NO EVENT PRE-PIPE CLOSER THAN FIVE FEET FROM MACHINE. FACTORY MUST BE CONSULTED FOR DIMENSIONS IF MACHINE IS TO BE MOVED THROUGH NARROW OR LOW CORRIDORS OR OPENINGS.
- ATTENTION**
- MOST REGULATORY AUTHORITIES (INCLUDING OSHA IN THE USA) HOLD THE OWNER/USER ULTIMATELY RESPONSIBLE TO MAINTAIN A SAFE WORKING ENVIRONMENT. ACCORDINGLY, THE OWNER/USER MUST RECOGNIZE ALL FORESEEABLE SAFETY HAZARDS, FURNISH SAFETY INSTRUCTIONS AND GUIDANCE TO ALL PERSONNEL WHO MAY COME IN CONTACT WITH THE INSTALLATION, AND PROVIDE ALL NECESSARY ADDITIONAL SAFETY GUARDS, FENCES, RESTRAINTS, DEVICES, ETC., NOT FURNISHED BY THE EQUIPMENT MANUFACTURER OR VENDOR.
- ATTENTION**
- THE FLOOR AND/OR OTHER SUPPORT COMPONENTS MUST HAVE SUFFICIENT STRENGTH (AND RIGIDITY WITH DUE CONSIDERATION FOR NATURAL OR RESONANT FREQUENCY THEREOF) TO WITHSTAND THE FULLY LOADED WEIGHT OF THE MACHINE INCLUDING THE GOODS, THE WATER, AND ANY REPEATED SINUSOIDAL (ROTATING) FORCES GENERATED DURING ITS OPERATION. WRITE THE FACTORY FOR ADDITIONAL MACHINE DATA FOR USE BY A COMPETENT SOIL AND/OR STRUCTURAL ENGINEER.

COLFR112 (120K CAKES)

DWG# BDCOLFR2AE
 2023333D
MILNOR PELLERIN MILNOR CORPORATION
 P.O. Box 400 Kenner, LA 70063, USA, Phone 504/467-9591,
 FAX 504/468-3094, Email: milnorinfo@milnor.com

WHEN THIS DRYER PEDESTAL EXTENDER IS USED WITH DRYER 8282		WHEN THIS DRYER PEDESTAL EXTENDER IS USED WITH DRYER 7676		WHEN THIS DRYER PEDESTAL EXTENDER IS USED WITH DRYER 6458,6464		USE THIS SIDE RAIL EXTENDER COLFR112		COLFR112 HORIZONTAL BEDS				DIMENSION "D" 6458,6464 LOAD HEIGHT		DIMENSION "D" 7676,8282 LOAD HEIGHT			
INCHES	mm	INCHES	mm	INCHES	mm	INCHES	mm	DIMENSION "A" INCHES	mm	DIMENSION "C" WITH 6458,6464 INCHES	mm	DIMENSION "C" WITH 7676,8282 INCHES	mm	INCHES	mm	INCHES	mm
0	0	-7	-178	0	0	72 1/2	1842	166 1/2	4229	71	1803	73 1/2	1867	68 1/2	1740	69 1/2	1765
3 1/2	89	-3 1/2	-89	3 1/2	89	76	1930	170	4318	74 1/2	1892	76 1/2	1943	72	1829	73	1854
10 1/2	267	0	0	7	178	79 1/2	2019	173 1/2	4407	78	1981	80 1/2	2045	75 1/2	1918	76 1/2	1943
17 1/2	445	3 1/2	89	10 1/2	267	83	2108	177	4496	81 1/2	2070	84	2134	79	2007	80	2032
		7	178	14	356	86 1/2	2197	180 1/2	4585	85	2159	87 1/2	2223	82 1/2	2096	83 1/2	2121
		14	356	17 1/2	445	90	2286	184	4674	88 1/2	2248	94 1/2	2400	86	2184	90 1/2	2299
		21	533	24 1/2	622	97	2464	191	4851	95 1/2	2426	101 1/2	2578	93	2362	97 1/2	2477
				31 1/2	800	104	2642	198	5029	102 1/2	2604						

* FOR HIGHER PEDESTALS, CONSULT FACTORY.



ITEM	LEGEND
S1	TIE RODS, SUPPLIED ONLY FOR SHUTTLES WITH 48" [1224] EXTENDERS OR LONGER.
M3	HOIST MOTOR AND WINCH.
M2	BELT MOTORS, ALTERNATES LEFT/RIGHT PER LEVEL.
M1	DRIVE MOTOR, UNDER CART FRAME, NOT VISIBLE.
F1	ANCHOR BOLT HOLE 7/8" [22] DIAMETER, 6 PLACES
E3	EMERGENCY STOP BUTTON
E2	CONTROL BOX
E1	MICROPROCESSOR BOX
D1	DRYER LOAD SHELF
B1	COLF STAND

- NOTES**
- FOR THE DIMENSION FROM "Y" OF THE SHUTTLE TO "Y" OF THE DRYER, SEE THE DRYER DIMENSIONAL DRAWING.
 - THE 6458 DRYER AT "ZERO PEDESTAL" HAS A 41" [1041] HIGH BASE. THE DRYER MAY BE ORDERED TO INCREASE OR DECREASE THE MACHINE HEIGHT, THEREFORE, NEGATIVE PEDESTAL HEIGHTS ARE POSSIBLE. CONSULT MILNOR FACTORY.
 - DIMENSION VARIES WITH HEIGHT OF EXTENDERS WHEN ADDED.
 - EMERGENCY STOPS ARE REQUIRED ON BOTH LEFT AND RIGHT SIDES OF THE COLF. ONE IS INSTALLED INTO THE DOOR OF THE COLF CONTROL BOX.
 - AFTER MACHINE HAS BEEN COMMISSIONED, BELT MAY STRETCH SLIGHTLY REQUIRING ADJUSTMENT OF BELT ROLLERS AND SLIGHT LENGTHENING OF CONVEYOR.
 - AS OF THIS WRITING, THE MINIMUM CLEARANCE REQUIRED BY U.S. NATIONAL ELECTRIC CODES, FROM ELECTRIC BOX TO ANY OBJECT IS:
 - 36 [914] IF OBJECT IS AN UNGROUNDED (INSULATED) WALL
 - 42 [1067] IF OBJECT IS A GROUNDED WALL (ie. BARE CONCRETE, BRICK, ETC.)
 - 48 [1219] IF OBJECT IS ANY LIVE PART.
 CHECK LOCAL ELECTRIC CODES FOR FURTHER RESTRICTIONS.
 - CUSTOMER TO SUPPLY CIRCUIT BREAKER OR FUSED BRANCH CIRCUIT DISCONNECT (SAFETY) SWITCHES WITH LAG TYPE FUSES FROM POWER SOURCE TO MACHINE. A SEPARATE GROUND WIRE MUST BE CONNECTED FROM DISCONNECT TO EQUIPMENT.
 - BASELINE "Z" IS THE SAME FOR ALL MILNOR MACHINES AND IS SHOWN ON ALL DIMENSIONAL DRAWINGS. THE DISTANCE BETWEEN BASELINE "Z" AND THE FINISHED FLOOR MAY VARY (WITH CHANGES IN FLOOR HEIGHT) AS REQUIRED TO INSURE THAT BASELINE "Z" IS HORIZONTAL AND ALL COMPONENTS REQUIRING GROUT ARE SET ON A MINIMUM 1" [25] THICK GROUT BED.
 - USE REFERENCE LINES "X", "Y", AND "Z" TO LOCATE ALL SERVICE CONNECTIONS.
 - NUMBERS IN BRACKETS [] DENOTE DIMENSIONS IN MILLIMETERS.
 - ALL DIMENSIONS SHOWN ARE APPROXIMATE, SUBJECT TO NORMAL MANUFACTURING TOLERANCES, AND TO OCCASIONAL CHANGES WITHOUT NOTICE THROUGH REDESIGN AND/OR RELOCATION OF COMPONENTS, ETC. DO NOT USE FOR CONSTRUCTION UNLESS CERTIFIED, AND IN NO EVENT PRE-PIPE CLOSER THAN FIVE FEET FROM MACHINE. FACTORY MUST BE CONSULTED FOR DIMENSIONS IF MACHINE IS TO BE MOVED THROUGH NARROW OR LOW CORRIDORS OR OPENINGS.
- ATTENTION**
- MOST REGULATORY AUTHORITIES (INCLUDING OSHA IN THE USA) HOLD THE OWNER/USER ULTIMATELY RESPONSIBLE TO MAINTAIN A SAFE WORKING ENVIRONMENT. ACCORDINGLY, THE OWNER/USER MUST RECOGNIZE ALL FORESEEABLE SAFETY HAZARDS, FURNISH SAFETY INSTRUCTIONS AND GUIDANCE TO ALL PERSONNEL WHO MAY COME IN CONTACT WITH THE INSTALLATION, AND PROVIDE ALL NECESSARY ADDITIONAL SAFETY GUARDS, FENCES, RESTRAINTS, DEVICES, ETC., NOT FURNISHED BY THE EQUIPMENT MANUFACTURER OR VENDOR.
- ATTENTION**
- THE FLOOR AND/OR OTHER SUPPORT COMPONENTS MUST HAVE SUFFICIENT STRENGTH (AND RIGIDITY WITH DUE CONSIDERATION FOR NATURAL OR RESONANT FREQUENCY THEREOF) TO WITHSTAND THE FULLY LOADED WEIGHT OF THE MACHINE INCLUDING THE GOODS, THE WATER, AND ANY REPEATED SINUSOIDAL (ROTATING) FORCES GENERATED DURING ITS OPERATION. WRITE THE FACTORY FOR ADDITIONAL MACHINE DATA FOR USE BY A COMPETENT SOIL AND/OR STRUCTURAL ENGINEER.

COLFR112 HORIZONTAL (120K CAKES)

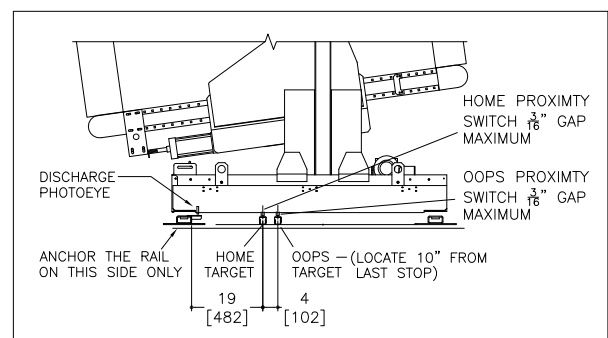
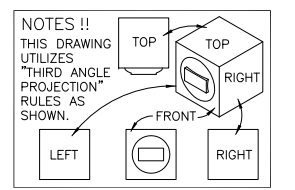
DM 0 0.5M
INCHES 0 12 24

DWG# BDCOLFR2AB
2023333D

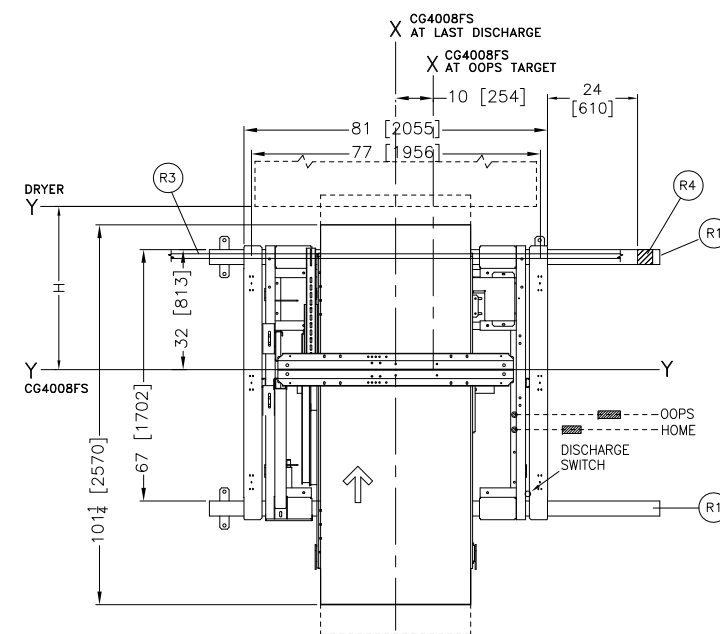
MILNOR PELLERIN MILNOR CORPORATION
P.O. Box 400 Kenner, LA 70063, USA, Phone 504/467-9591,
FAX 504/468-3094, Email: milnorinfo@milnor.com

WHEN THIS DRYER PEDESTAL EXTENDER IS USED WITH DRYER 7272TG1/TS1		WHEN THIS DRYER PEDESTAL EXTENDER IS USED WITH DRYER 6458TG1/TS1		WHEN THIS DRYER PEDESTAL EXTENDER IS USED WITH DRYER 58080TG1/TS1		WHEN THIS DRYER PEDESTAL EXTENDER IS USED WITH DRYER 58058TG2/TS1		WHEN THIS DRYER PEDESTAL EXTENDER IS USED WITH DRYER 58040TG2/TS1		WHEN THIS DRYER PEDESTAL EXTENDER IS USED WITH DRYER 50040TS1		USE THIS SIDE RAIL EXTENDER CG4008FS		RESULTING CG4008FS DIMENSIONS				DIMENSION "D" 58XX DRYERS LOAD HEIGHT		DIMENSION "D" 5040, 6458, & 7272 DRYERS LOAD HEIGHT			
INCHES	mm	INCHES	mm	INCHES	mm	INCHES	mm	INCHES	mm	INCHES	mm	INCHES	mm	DIMENSION "A"		DIMENSION "B"		DIMENSION "C"		INCHES	mm	INCHES	mm
-7	-178	0	0	-	-	-	-	10 1/2	267	10 1/2	267	10 1/2	267	77	1956	132 1/2	3366	126 1/2	3213	69 1/2	1765	68	1727
-3 1/2	-89	3 1/2	89	-	-	0	0	14	356	14	356	14	356	80 1/2	2045	136	3454	130	3302	73	1854	71 1/2	1816
0	0	7	178	-	-	3 1/2	89	17 1/2	445	17 1/2	445	17 1/2	445	84	2134	139 1/2	3543	133 1/2	3391	76 1/2	1943	75	1905
3 1/2	89	10 1/2	267	0	0	7	178	21	533	21	533	21	533	87 1/2	2223	143	3632	137	3480	80	2032	78 1/2	1994
7	178	14	356	3 1/2	89	10 1/2	267	24 1/2	622	24 1/2	622	24 1/2	622	91	2311	146 1/2	3721	140 1/2	3569	83 1/2	2121	82	2083
14	356	21	533	10 1/2	267	17 1/2	445	31 1/2	800	31 1/2	800	31 1/2	800	98	2489	153 1/2	3899	147 1/2	3747	90 1/2	2299	89	2261
21	533	28	711	17 1/2	445	24 1/2	622	38 1/2	978	38 1/2	978	38 1/2	978	105	2667	160 1/2	4077	154 1/2	3924	97 1/2	2477	96	2438
28	711	35	889	24 1/2	622	31 1/2	800	45 1/2	1156	45 1/2	1156	45 1/2	1156	112	2845	167 1/2	4255	161 1/2	4102	104 1/2	2654	103	2616
35	889	42	1067	31 1/2	800	38 1/2	978	52 1/2	1334	52 1/2	1334	52 1/2	1334	119	3023	174 1/2	4432	168 1/2	4280	111 1/2	2832	110	2794
42	1067	49	1245	38 1/2	978	45 1/2	1156	59 1/2	1511	59 1/2	1511	59 1/2	1511	126	3200	181 1/2	4610	175 1/2	4458	118 1/2	3010	117	2975
49	1245	56	1422	45 1/2	1156	52 1/2	1334	66 1/2	1689	66 1/2	1689	66 1/2	1689	133	3378	188 1/2	4788	182 1/2	4636	125 1/2	3188	124	3150

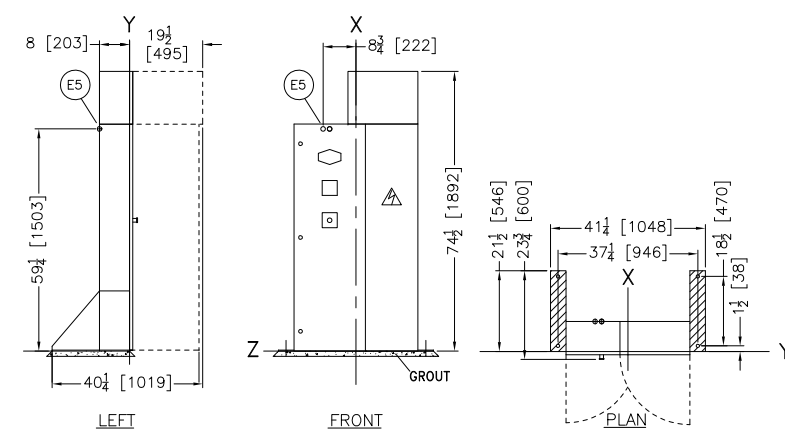
DRYER MODELS	CG4008FS TO DRYER H	
	INCHES	mm
58040	43 1/2	1105
58058	43 1/2	1105
58080	43 1/2	1105
6458	43 1/2	1105
7272	43 1/2	1105



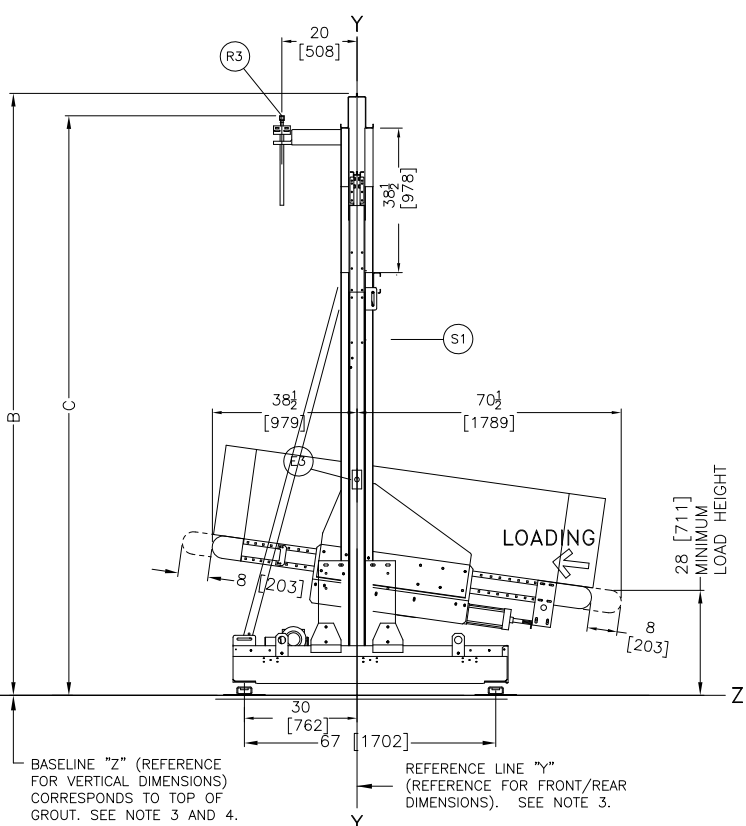
TARGET & SWITCH INSTALLATION



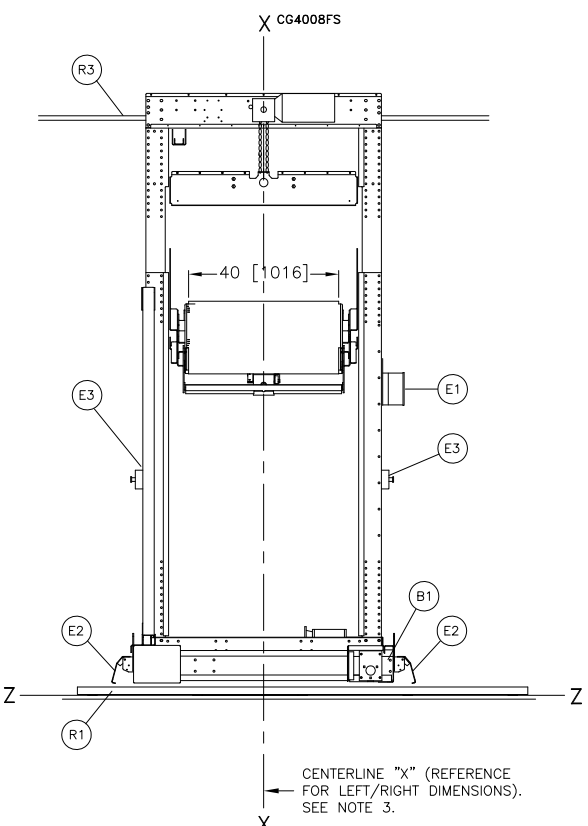
PLAN VIEW



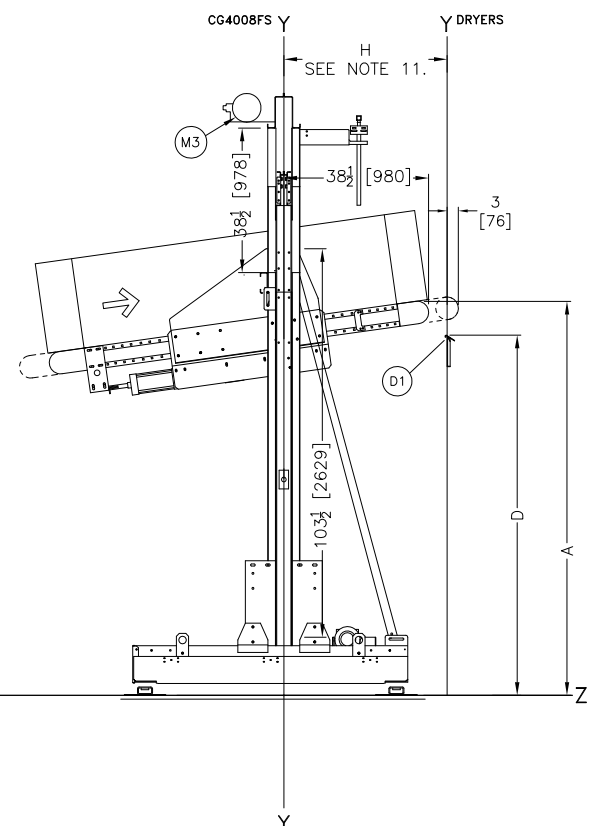
REMOTE MOUNT SHUTTLE CONTROL BOX
SEE NOTE 10.



LEFT VIEW



FRONT VIEW



RIGHT VIEW

ITEM	LEGEND
S1	TIE RODS, SUPPLIED ONLY FOR SHUTTLES WITH 48" [1624] EXTENDERS OR LONGER.
R4	POSITIVE STOP
R3	FESTOON RAIL. RAIL SUPPLIED BY MILNOR AND MAY BE PRICED SEPARATELY. SEE PRICE LIST.
R1	FLOOR DRIVE RAILS. RAIL SUPPLIED BY MILNOR AND MAY BE PRICED SEPARATELY. SEE PRICE LIST.
M3	HOIST MOTOR AND WINCH.
M2	BELT MOTORS, ALTERNATES LEFT/RIGHT PER LEVEL.
M1	DRIVE MOTOR, UNDER CART FRAME, NOT VISIBLE.
F1	FESTOON CABLE
E5	ELECTRICAL & CONTROL CABLE CONNECTIONS FOR REMOTE SHUTTLE CONTROL BOX
E3	EMERGENCY STOP BUTTON
E2	EMERGENCY STOP KICK PLATE
E1	JUNCTION BOX
D1	LOAD DOOR SHELF
B1	CART FRAME WELDMENT

- NOTES**
- THE SHUTTLE NAME CONFIGURATION IS AS FOLLOWS:
CF = CART DRIVEN/TRANSLATE/ELEVATE
40 = BELT WIDTH IN INCHES
08 = LENGTH OF BED = 8'[2438]
F = 8" TO LOAD + 8" TO DISCHARGE
S = SINGLE BED
 - DIMENSION "H" IS FROM "Y" OF THE SHUTTLE TO "Y" OF THE DRYER. SEE DRYER DIMENSIONAL DRAWINGS.
 - CONTROLS FOR THE COSHM SHUTTLE ARE CONTAINED IN THIS REMOTELY MOUNTED SHUTTLE CONTROL BOX WHICH MUST BE PLACED IN THE EQUIPMENT LAYOUT.
 - DIMENSION VARIES WITH HEIGHT OF EXTENDERS WHEN ADDED.
 - EMERGENCY STOPS ARE REQUIRED ON BOTH LEFT AND RIGHT SIDES OF THE SHUTTLE. A THIRD EMERGENCY STOP IS INSTALLED INTO THE DOOR OF THE REMOTE SHUTTLE CONTROL BOX.
 - AFTER MACHINE HAS BEEN COMMISSIONED, BELT MAY STRETCH SLIGHTLY REQUIRING ADJUSTMENT OF BELT ROLLERS AND SLIGHT LENGTHENING OF CONVEYOR.
 - AS OF THIS WRITING, THE MINIMUM CLEARANCE REQUIRED BY U.S. NATIONAL ELECTRIC CODES, FROM ELECTRIC BOX TO ANY OBJECT IS:
36 [914] IF OBJECT IS AN UNGROUNDED (INSULATED) WALL
42 [1067] IF OBJECT IS A GROUNDED WALL (ie. BARE CONCRETE, BRICK, ETC.)
48 [1219] IF OBJECT IS ANY LIVE PART.
CHECK LOCAL ELECTRIC CODES FOR FURTHER RESTRICTIONS.
 - CUSTOMER TO SUPPLY CIRCUIT BREAKER OR FUSED BRANCH CIRCUIT DISCONNECT (SAFETY) SWITCHES WITH LAG TYPE FUSES FROM POWER SOURCE TO MACHINE. A SEPARATE GROUND WIRE MUST BE CONNECTED FROM DISCONNECT TO EQUIPMENT.
 - BASELINE "Z" IS THE REFERENCE FOR ALL VERTICAL DIMENSIONS. ON MACHINES WITH FIXED BASE PADS, BASELINE "Z" CORRESPONDS TO THE BOTTOM OF THE BASE PAD. ON MACHINES WITH ADJUSTABLE FEET, BASELINE "Z" CORRESPONDS TO THE BOTTOM OF THE FEET WHEN ADJUSTED SO THAT THE MACHINE IS AT ITS MINIMUM ACCEPTABLE HEIGHT. ON TRAVERSING SHUTTLES, BASELINE "Z" CORRESPONDS TO THE BOTTOM OF THE BOTTOM RAIL. THE DISTANCE BETWEEN BASELINE "Z" AND THE FINISHED FLOOR WILL VARY AS REQUIRED TO ENSURE BASELINE "Z" IS HORIZONTAL AND ANY INTERFACING MACHINES REQUIRING GROUT ARE SET ON A MINIMUM 1[25] THICK GROUT BED.
 - USE REFERENCE LINES "X", "Y", AND "Z" TO LOCATE ALL SERVICE CONNECTIONS.
 - NUMBERS IN BRACKETS [] DENOTE DIMENSIONS IN MILLIMETERS.
 - ALL DIMENSIONS SHOWN ARE APPROXIMATE, SUBJECT TO NORMAL MANUFACTURING TOLERANCES, AND TO OCCASIONAL CHANGES WITHOUT NOTICE THROUGH REDESIGN AND/OR RELOCATION OF COMPONENTS, ETC. DO NOT USE FOR CONSTRUCTION UNLESS CERTIFIED, AND IN NO EVENT PRE-PIPE CLOSER THAN FIVE FEET FROM MACHINE. FACTORY MUST BE CONSULTED FOR DIMENSIONS IF MACHINE IS TO BE MOVED THROUGH NARROW OR LOW CORRIDORS OR OPENINGS.

ATTENTION
MOST REGULATORY AUTHORITIES (INCLUDING OSHA IN THE USA) HOLD THE OWNER/USER ULTIMATELY RESPONSIBLE TO MAINTAIN A SAFE WORKING ENVIRONMENT. ACCORDINGLY, THE OWNER/USER MUST RECOGNIZE ALL FORESEEABLE SAFETY HAZARDS, FURNISH SAFETY INSTRUCTIONS AND GUIDANCE TO ALL PERSONNEL WHO MAY COME IN CONTACT WITH THE INSTALLATION, AND PROVIDE ALL NECESSARY ADDITIONAL SAFETY GUARDS, FENCES, RESTRAINTS, DEVICES, ETC., NOT FURNISHED BY THE EQUIPMENT MANUFACTURER OR VENDOR.

ATTENTION
THE FLOOR AND/OR OTHER SUPPORT COMPONENTS MUST HAVE SUFFICIENT STRENGTH (AND RIGIDITY WITH DUE CONSIDERATION FOR NATURAL OR RESONANT FREQUENCY THEREOF) TO WITHSTAND THE FULLY LOADED WEIGHT OF THE MACHINE INCLUDING THE GOODS, THE WATER, AND ANY REPEATED SINUSOIDAL (ROTATING) FORCES GENERATED DURING ITS OPERATION. WRITE THE FACTORY FOR ADDITIONAL MACHINE DATA FOR USE BY A COMPETENT SOIL AND/OR STRUCTURAL ENGINEER.

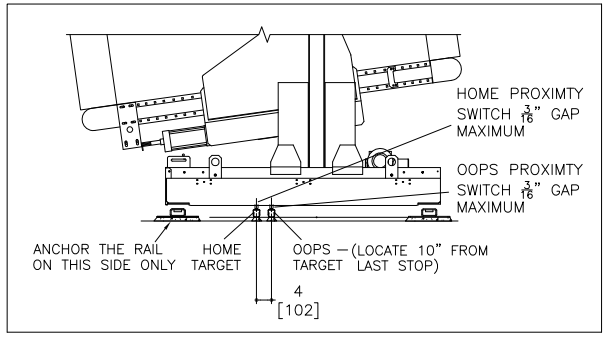
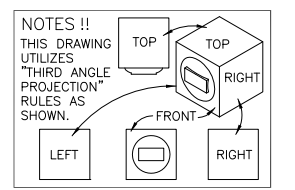
CG4008FS

DM 0 0.5M 1M
INCHES 0 12 24 36 DWG# BDCG40FSAE 2009182D

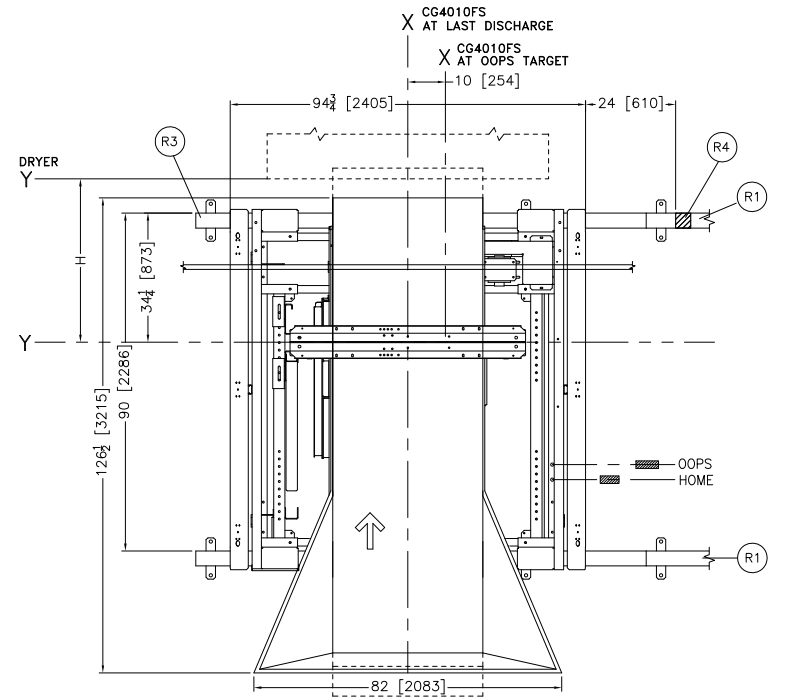
MILNOR PELLERIN MILNOR CORPORATION
P.O. Box 400 Kenner, LA 70063, USA, Phone 504/467-9591, FAX 504/469-1849, Email: mktg@milnor.com

WHEN THIS DRYER PEDESTAL EXTENDER IS USED WITH DRYER 7272TG1/TS1		WHEN THIS DRYER PEDESTAL EXTENDER IS USED WITH DRYER 6458TG1/TS1		WHEN THIS DRYER PEDESTAL EXTENDER IS USED WITH DRYER 58080TG1/TS1		WHEN THIS DRYER PEDESTAL EXTENDER IS USED WITH DRYER 58058TG2/TS1		WHEN THIS DRYER PEDESTAL EXTENDER IS USED WITH DRYER 58040TG2/TS1		WHEN THIS DRYER PEDESTAL EXTENDER IS USED WITH DRYER 50040TS1		USE THIS SIDE RAIL EXTENDER CG4010FS				RESULTING CG4010FS DIMENSIONS						DIMENSION "D" 58XX DRYERS LOAD HEIGHT		DIMENSION "D" 5040, 6458, & 7272 DRYERS LOAD HEIGHT	
INCHES	mm	INCHES	mm	INCHES	mm	INCHES	mm	INCHES	mm	INCHES	mm	INCHES	mm	INCHES	mm	INCHES	mm	INCHES	mm	INCHES	mm	INCHES	mm	INCHES	mm
-7	-178	0	0	-	-	-	-	10 1/2	267	10 1/2	267	17 1/2	444	77	1956	133	3378	126 1/2	3213	69 1/2	1765	68	1727		
-3 1/2	-89	3 1/2	89	-	-	0	0	14	356	14	356	21	553	80 1/2	2045	136 1/2	3467	130	3302	73	1854	71 1/2	1816		
0	0	7	178	-	-	3 1/2	89	17 1/2	445	17 1/2	445	24 1/2	622	84	2134	140	3556	133 1/2	3391	76 1/2	1943	75	1905		
3 1/2	89	10 1/2	267	0	0	7	178	21	533	21	533	28	711	87 1/2	2223	143 1/2	3645	137	3480	80	2032	78 1/2	1994		
7	178	14	356	3 1/2	89	10 1/2	267	24 1/2	622	24 1/2	622	31 1/2	800	91	2311	147	3734	140 1/2	3569	83 1/2	2121	82	2083		
14	356	21	533	10 1/2	267	17 1/2	445	31 1/2	800	31 1/2	800	38 1/2	978	98	2489	154	3912	147 1/2	3747	90 1/2	2299	89	2261		
21	533	28	711	17 1/2	445	24 1/2	622	38 1/2	978	38 1/2	978	45 1/2	1156	105	2667	161	4089	154 1/2	3924	97 1/2	2477	96	2438		
28	711	35	889	24 1/2	622	31 1/2	800	45 1/2	1156	45 1/2	1156	52 1/2	1334	112	2845	168	4267	161 1/2	4102	104 1/2	2654	103	2616		
35	889	42	1067	31 1/2	800	38 1/2	978	52 1/2	1334	52 1/2	1334	59 1/2	1511	119	3023	175	4445	168 1/2	4280	111 1/2	2832	110	2794		
42	1067	49	1245	38 1/2	978	45 1/2	1156	59 1/2	1511	59 1/2	1511	66 1/2	1689	126	3200	182	4623	175 1/2	4458	118 1/2	3010	117	2975		
49	1245	56	1422	45 1/2	1156	52 1/2	1334	66 1/2	1689	66 1/2	1689	73 1/2	1867	133	3378	189	4801	182 1/2	4636	125 1/2	3188	124	3150		

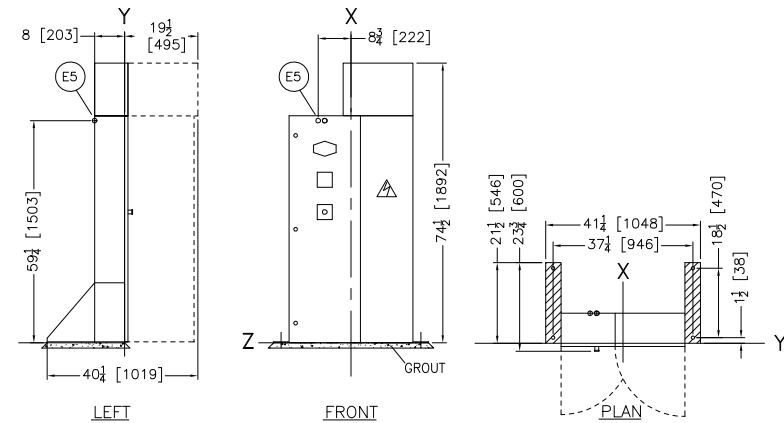
DRYER MODELS	CG4008FS TO DRYER H	
	INCHES	mm
58040	43 1/2	1105
58058	43 1/2	1105
58080	43 1/2	1105
6458	43 1/2	1105
7272	43 1/2	1105



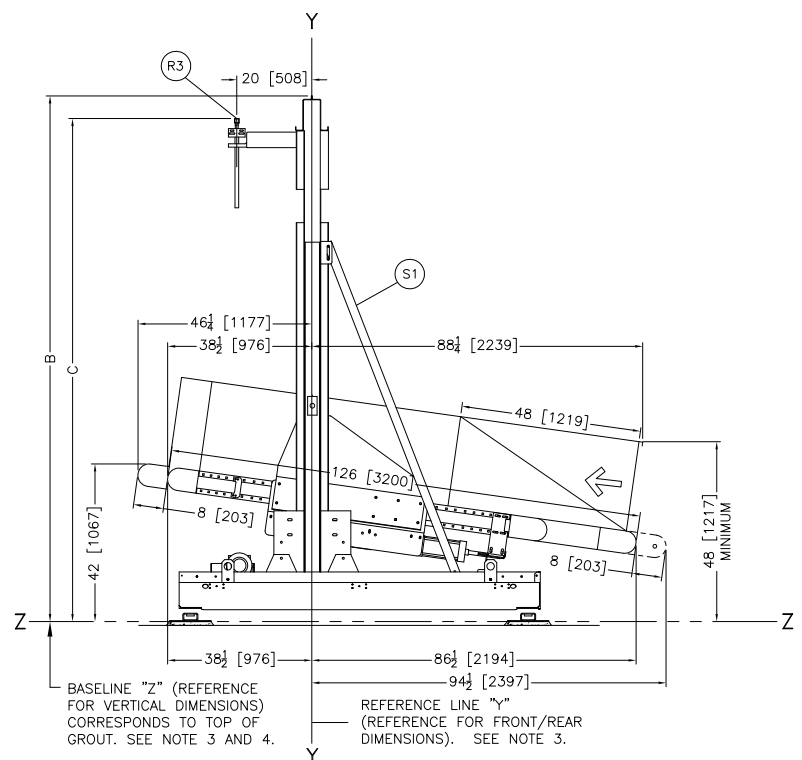
TARGET & SWITCH INSTALLATION



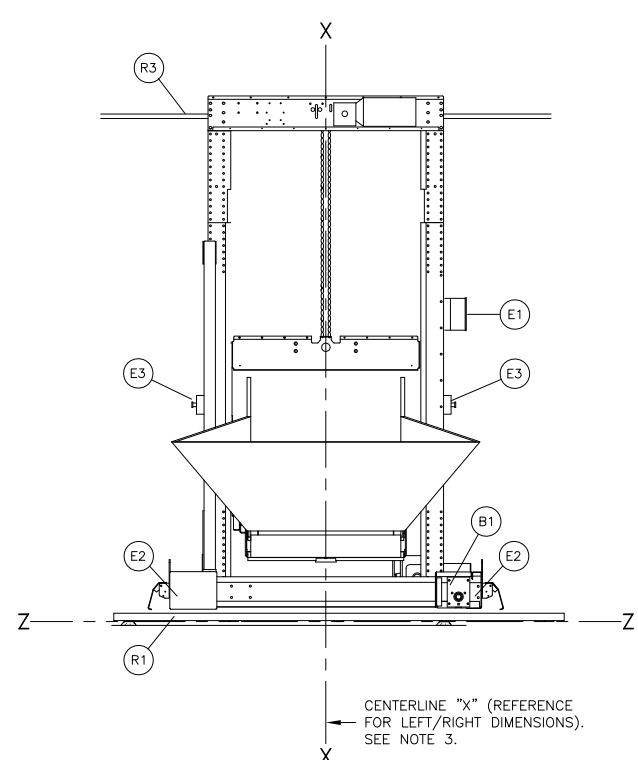
PLAN VIEW



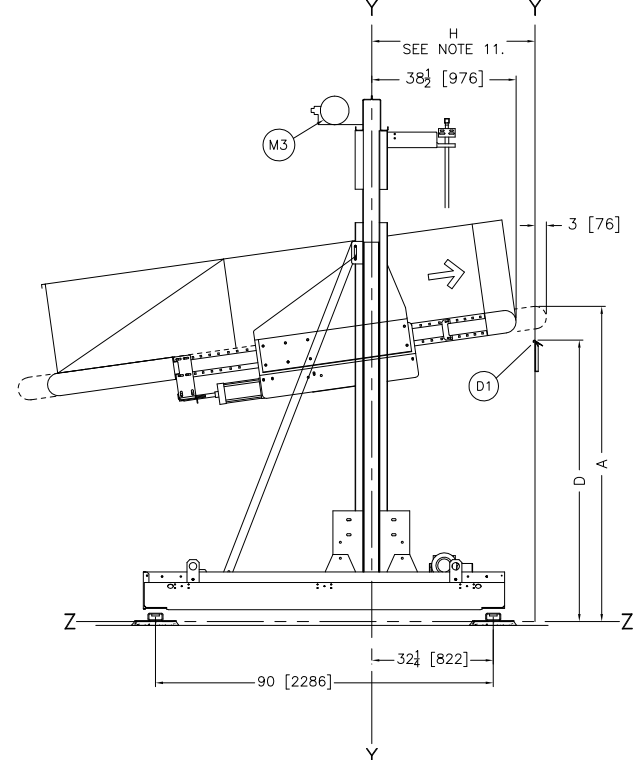
REMOTE MOUNT SHUTTLE CONTROL BOX
SEE NOTE 10.



LEFT VIEW



FRONT VIEW



RIGHT VIEW

ITEM	LEGEND
S1	TIE RODS, SUPPLIED ONLY FOR SHUTTLES WITH 48" [1624] EXTENDERS OR LONGER.
R4	POSITIVE STOP
R3	FESTOON RAIL. RAIL SUPPLIED BY MILNOR AND MAY BE PRICED SEPARATELY. SEE PRICE LIST.
R1	FLOOR DRIVE RAILS. RAIL SUPPLIED BY MILNOR AND MAY BE PRICED SEPARATELY. SEE PRICE LIST.
M3	HOIST MOTOR AND WINCH.
M2	BELT MOTORS, ALTERNATES LEFT/RIGHT PER LEVEL.
M1	DRIVE MOTOR, UNDER CART FRAME, NOT VISIBLE.
F1	FESTOON CABLE
E5	ELECTRICAL & CONTROL CABLE CONNECTIONS FOR REMOTE SHUTTLE CONTROL BOX
E3	EMERGENCY STOP BUTTON
E2	EMERGENCY STOP KICK PLATE
E1	JUNCTION BOX
D1	LOAD DOOR SHELF
B1	CART FRAME WELDMENT

NOTES

12 THE SHUTTLE NAME CONFIGURATION IS AS FOLLOWS:
CF = CART DRIVEN/TRANSLATE/ELEVATE
40 = BELT WIDTH IN INCHES
10 = LENGTH OF BED = 10'[3200]
F = 8" TO LOAD + 8" TO DISCHARGE
S = SINGLE BED

11 DIMENSION "H" IS FROM "Y" OF THE SHUTTLE TO "Y" OF THE DRYER. SEE DRYER DIMENSIONAL DRAWINGS.

10 CONTROLS FOR THE COSHM SHUTTLE ARE CONTAINED IN THIS REMOTELY MOUNTED SHUTTLE CONTROL BOX WHICH MUST BE PLACED IN THE EQUIPMENT LAYOUT.

9 DIMENSION VARIES WITH HEIGHT OF EXTENDERS WHEN ADDED.

8 EMERGENCY STOPS ARE REQUIRED ON BOTH LEFT AND RIGHT SIDES OF THE SHUTTLE. A THIRD EMERGENCY STOP IS INSTALLED INTO THE DOOR OF THE REMOTE SHUTTLE CONTROL BOX.

7 AFTER MACHINE HAS BEEN COMMISSIONED, BELT MAY STRETCH SLIGHTLY REQUIRING ADJUSTMENT OF BELT ROLLERS AND SLIGHT LENGTHENING OF CONVEYOR.

6 AS OF THIS WRITING, THE MINIMUM CLEARANCE REQUIRED BY U.S. NATIONAL ELECTRIC CODES, FROM ELECTRIC BOX TO ANY OBJECT IS:
36 [914] IF OBJECT IS AN UNGROUNDED (INSULATED) WALL
42 [1067] IF OBJECT IS A GROUNDED WALL (ie. BARE CONCRETE, BRICK, ETC.)
48 [1219] IF OBJECT IS ANY LIVE PART.
CHECK LOCAL ELECTRIC CODES FOR FURTHER RESTRICTIONS.

5 CUSTOMER TO SUPPLY CIRCUIT BREAKER OR FUSED BRANCH CIRCUIT DISCONNECT (SAFETY) SWITCHES WITH LAG TYPE FUSES FROM POWER SOURCE TO MACHINE. A SEPARATE GROUND WIRE MUST BE CONNECTED FROM DISCONNECT TO EQUIPMENT.

4 BASELINE "Z" IS THE REFERENCE FOR ALL VERTICAL DIMENSIONS. ON MACHINES WITH FIXED BASE PADS, BASELINE "Z" CORRESPONDS TO THE BOTTOM OF THE BASE PAD. ON MACHINES WITH ADJUSTABLE FEET, BASELINE "Z" CORRESPONDS TO THE BOTTOM OF THE FEET WHEN ADJUSTED SO THAT THE MACHINE IS AT ITS MINIMUM ACCEPTABLE HEIGHT. ON TRAVERING SHUTTLES, BASELINE "Z" CORRESPONDS TO THE BOTTOM OF THE BOTTOM RAIL. THE DISTANCE BETWEEN BASELINE "Z" AND THE FINISHED FLOOR WILL VARY AS REQUIRED TO ENSURE BASELINE "Z" IS HORIZONTAL AND ANY INTERFACING MACHINES REQUIRING GROUT ARE SET ON A MINIMUM 1"[25] THICK GROUT BED.

3 USE REFERENCE LINES "X", "Y", AND "Z" TO LOCATE ALL SERVICE CONNECTIONS.

2 NUMBERS IN BRACKETS [] DENOTE DIMENSIONS IN MILLIMETERS.

1 ALL DIMENSIONS SHOWN ARE APPROXIMATE, SUBJECT TO NORMAL MANUFACTURING TOLERANCES, AND TO OCCASIONAL CHANGES WITHOUT NOTICE THROUGH REDESIGN AND/OR RELOCATION OF COMPONENTS, ETC. DO NOT USE FOR CONSTRUCTION UNLESS CERTIFIED, AND IN NO EVENT PRE-PIPE CLOSER THAN FIVE FEET FROM MACHINE. FACTORY MUST BE CONSULTED FOR DIMENSIONS IF MACHINE IS TO BE MOVED THROUGH NARROW OR LOW CORRIDORS OR OPENINGS.

ATTENTION
MOST REGULATORY AUTHORITIES (INCLUDING OSHA IN THE USA) HOLD THE OWNER/USER ULTIMATELY RESPONSIBLE TO MAINTAIN A SAFE WORKING ENVIRONMENT. ACCORDINGLY, THE OWNER/USER MUST RECOGNIZE ALL FORESEEABLE SAFETY HAZARDS, FURNISH SAFETY INSTRUCTIONS AND GUIDANCE TO ALL PERSONNEL WHO MAY COME IN CONTACT WITH THE INSTALLATION, AND PROVIDE ALL NECESSARY ADDITIONAL SAFETY GUARDS, FENCES, RESTRAINTS, DEVICES, ETC., NOT FURNISHED BY THE EQUIPMENT MANUFACTURER OR VENDOR.

ATTENTION
THE FLOOR AND/OR OTHER SUPPORT COMPONENTS MUST HAVE SUFFICIENT STRENGTH (AND RIGIDITY WITH DUE CONSIDERATION FOR NATURAL OR RESONANT FREQUENCY THEREOF) TO WITHSTAND THE FULLY LOADED WEIGHT OF THE MACHINE INCLUDING THE GOODS, THE WATER, AND ANY REPEATED SINUSOIDAL (ROTATING) FORCES GENERATED DURING ITS OPERATION. WRITE THE FACTORY FOR ADDITIONAL MACHINE DATA FOR USE BY A COMPETENT SOIL AND/OR STRUCTURAL ENGINEER.

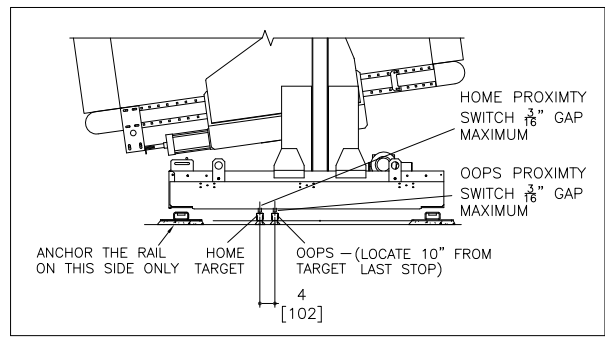
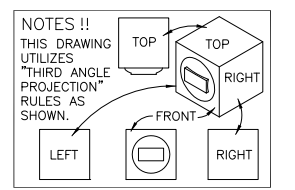
CG4010FS

DM 0 0.5M 1M
INCHES 0 12 24 36 DWG# BDCG4010FSAE 2012444D

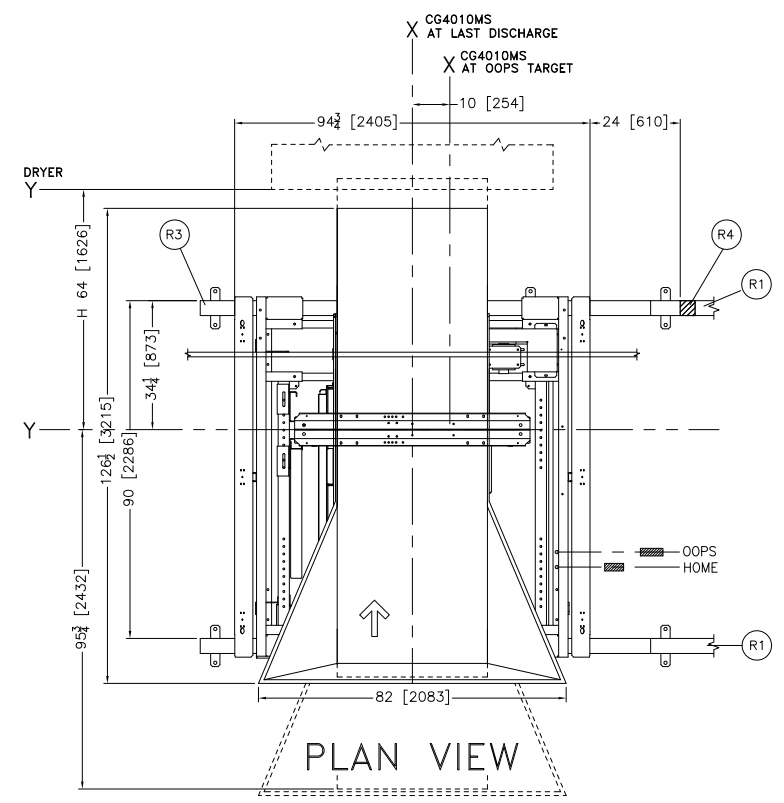
MILNOR PELLERIN MILNOR CORPORATION
P.O. Box 400 Kenner, LA 70063, USA, Phone 504/467-9591, FAX 504/469-1849, Email: mktg@milnor.com

WHEN THIS DRYER PEDESTAL EXTENDER IS USED WITH DRYER 7272TG1/TS1		WHEN THIS DRYER PEDESTAL EXTENDER IS USED WITH DRYER 6458TG1/TS1		WHEN THIS DRYER PEDESTAL EXTENDER IS USED WITH DRYER 58080TG1/TS1		WHEN THIS DRYER PEDESTAL EXTENDER IS USED WITH DRYER 58058TG2/TS1		WHEN THIS DRYER PEDESTAL EXTENDER IS USED WITH DRYER 58040TG2/TS1		WHEN THIS DRYER PEDESTAL EXTENDER IS USED WITH DRYER 50040TS1		USE THIS SIDE RAIL EXTENDER CG4010MS		RESULTING CG4010MS DIMENSIONS						DIMENSION "D"		DIMENSION "D"	
INCHES	mm	INCHES	mm	INCHES	mm	INCHES	mm	INCHES	mm	INCHES	mm	INCHES	mm	DIMENSION "A"		DIMENSION "B"		DIMENSION "c"		58XX DRYERS LOAD HEIGHT		5040, 6458, & 7272 DRYERS LOAD HEIGHT	
														INCHES	mm	INCHES	mm	INCHES	mm	INCHES	mm	INCHES	mm
-7	-178	0	0	-	-	-	-	10 1/2	267	10 1/2	267	17 1/2	444	77	1956	133	3378	126 1/2	3213	69 1/2	1765	68	1727
-3 1/2	-89	3 1/2	89	-	-	0	0	14	356	14	356	21	553	80 1/2	2045	136 1/2	3467	130	3302	73	1854	71 1/2	1816
0	0	7	178	-	-	3 1/2	89	17 1/2	445	17 1/2	445	24 1/2	622	84	2134	140	3556	133 1/2	3391	76 1/2	1943	75	1905
3 1/2	89	10 1/2	267	0	0	7	178	21	533	21	533	28	711	87 1/2	2223	143 1/2	3645	137	3480	80	2032	78 1/2	1994
7	178	14	356	3 1/2	89	10 1/2	267	24 1/2	622	24 1/2	622	31 1/2	800	91	2311	147	3734	140 1/2	3569	83 1/2	2121	82	2083
14	356	21	533	10 1/2	267	17 1/2	445	31 1/2	800	31 1/2	800	38 1/2	978	98	2489	154	3912	147 1/2	3747	90 1/2	2299	89	2261
21	533	28	711	17 1/2	445	24 1/2	622	38 1/2	978	38 1/2	978	45 1/2	1156	105	2667	161	4089	154 1/2	3924	97 1/2	2477	96	2438
28	711	35	889	24 1/2	622	31 1/2	800	45 1/2	1156	45 1/2	1156	52 1/2	1334	112	2845	168	4267	161 1/2	4102	104 1/2	2654	103	2616
35	889	42	1067	31 1/2	800	38 1/2	978	52 1/2	1334	52 1/2	1334	59 1/2	1511	119	3023	175	4445	168 1/2	4280	111 1/2	2832	110	2794
42	1067	49	1245	38 1/2	978	45 1/2	1156	59 1/2	1511	59 1/2	1511	66 1/2	1689	126	3200	182	4623	175 1/2	4458	118 1/2	3010	117	2975
49	1245	56	1422	45 1/2	1156	52 1/2	1334	66 1/2	1689	66 1/2	1689	73 1/2	1867	133	3378	189	4801	182 1/2	4636	125 1/2	3188	124	3150

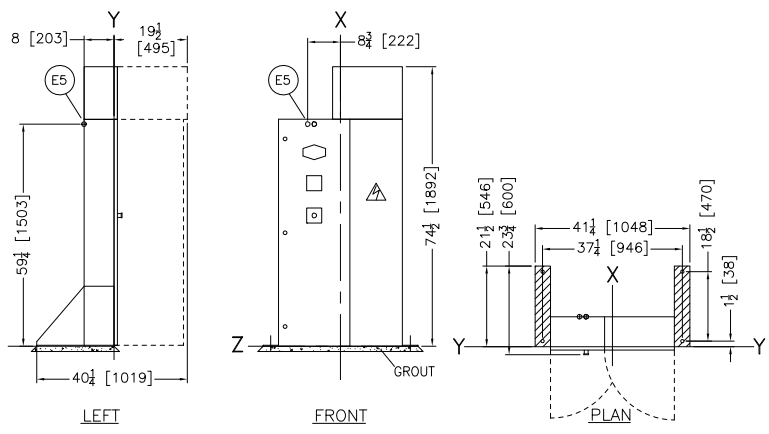
DRYER MODELS		CG4010MS TO DRYER H	
INCHES	mm	INCHES	mm
58058 58080		66	1676
64058 64064 72072 76076		64	1626



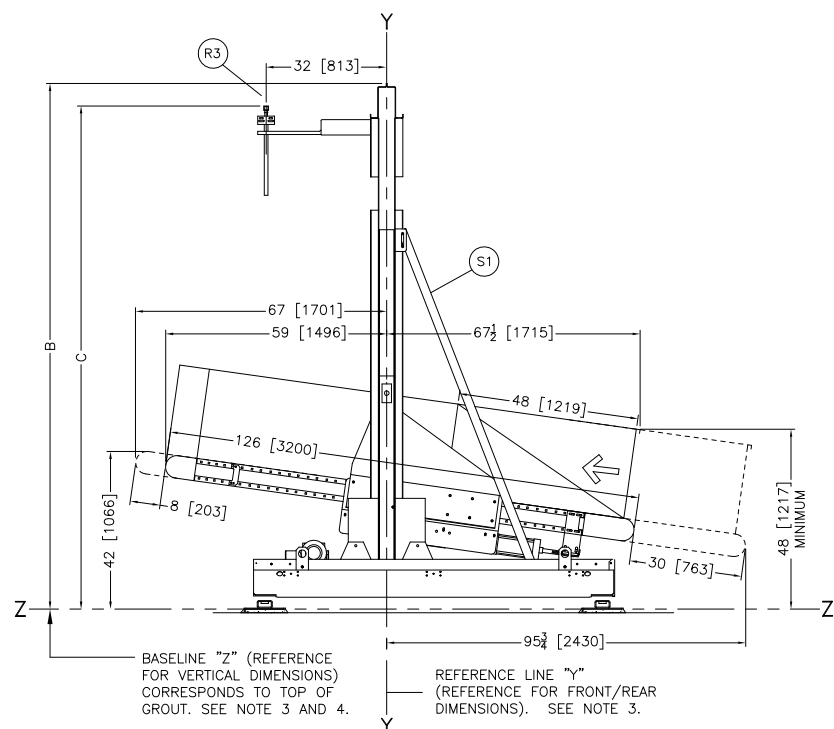
TARGET & SWITCH INSTALLATION



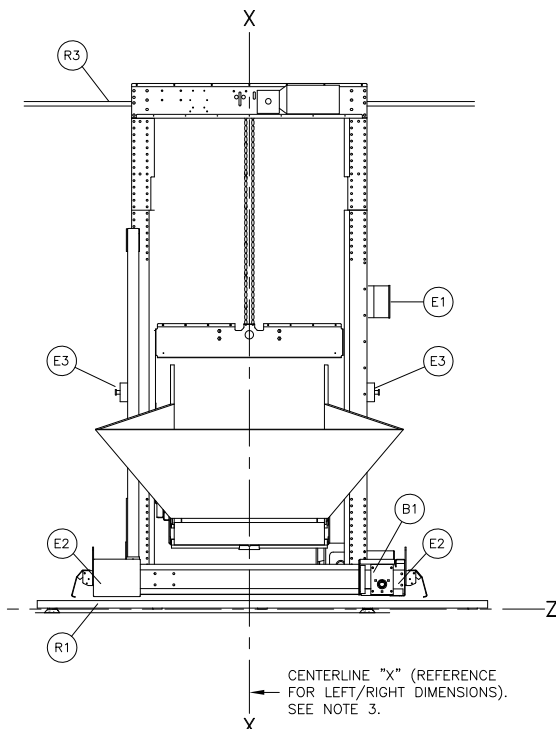
PLAN VIEW



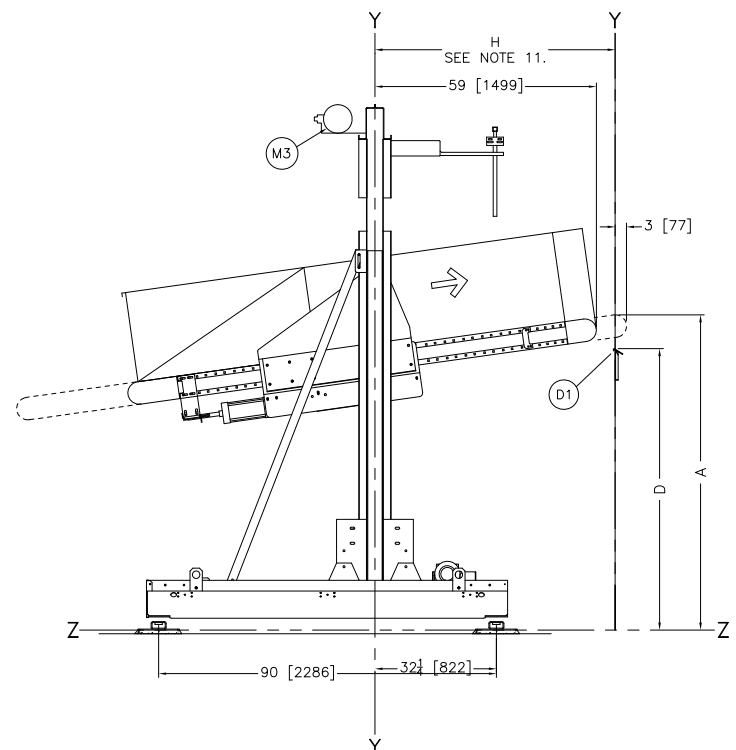
REMOTE MOUNT SHUTTLE CONTROL BOX
SEE NOTE 10.



LEFT VIEW



FRONT VIEW



RIGHT VIEW

S1	TIE RODS, SUPPLIED ONLY FOR SHUTTLES WITH 48" [1624] EXTENDERS OR LONGER.
R4	POSITIVE STOP
R3	FESTOON RAIL. RAIL SUPPLIED BY MILNOR AND MAY BE PRICED SEPARATELY. SEE PRICE LIST.
R1	FLOOR DRIVE RAILS. RAIL SUPPLIED BY MILNOR AND MAY BE PRICED SEPARATELY. SEE PRICE LIST.
M3	HOIST MOTOR AND WINCH.
M2	BELT MOTORS, ALTERNATES LEFT/RIGHT PER LEVEL.
M1	DRIVE MOTOR, UNDER CART FRAME, NOT VISIBLE.
F1	FESTOON CABLE
E5	ELECTRICAL & CONTROL CABLE CONNECTIONS FOR REMOTE SHUTTLE CONTROL BOX
E3	EMERGENCY STOP BUTTON
E2	EMERGENCY STOP KICK PLATE
E1	JUNCTION BOX
D1	LOAD DOOR SHELFL
B1	CART FRAME WELDMENT
ITEM	LEGEND

NOTES

12 THE SHUTTLE NAME CONFIGURATION IS AS FOLLOWS:
CG = CART DRIVEN/TRANSLATE/ELEVATE
40 = BELT WIDTH IN INCHES
10 = LENGTH OF BED = 10'[3200]
M = 30" TO LOAD + 8" TO DISCHARGE
S = SINGLE BED

11 DIMENSION "H" IS FROM "Y" OF THE SHUTTLE TO "Y" OF THE DRYER. SEE DRYER DIMENSIONAL DRAWINGS.

10 CONTROLS FOR THE COSHM SHUTTLE ARE CONTAINED IN THIS REMOTELY MOUNTED SHUTTLE CONTROL BOX WHICH MUST BE PLACED IN THE EQUIPMENT LAYOUT.

9 DIMENSION VARIES WITH HEIGHT OF EXTENDERS WHEN ADDED.

8 EMERGENCY STOPS ARE REQUIRED ON BOTH LEFT AND RIGHT SIDES OF THE SHUTTLE. A THIRD EMERGENCY STOP IS INSTALLED INTO THE DOOR OF THE REMOTE SHUTTLE CONTROL BOX.

7 AFTER MACHINE HAS BEEN COMMISSIONED, BELT MAY STRETCH SLIGHTLY REQUIRING ADJUSTMENT OF BELT ROLLERS AND SLIGHT LENGTHENING OF CONVEYOR.

6 AS OF THIS WRITING, THE MINIMUM CLEARANCE REQUIRED BY U.S. NATIONAL ELECTRIC CODES, FROM ELECTRIC BOX TO ANY OBJECT IS:
36 [914] IF OBJECT IS AN UNGROUNDED (INSULATED) WALL
42 [1067] IF OBJECT IS A GROUNDED WALL (ie. BARE CONCRETE, BRICK, ETC.)
48 [1219] IF OBJECT IS ANY LIVE PART.
CHECK LOCAL ELECTRIC CODES FOR FURTHER RESTRICTIONS.

5 CUSTOMER TO SUPPLY CIRCUIT BREAKER OR FUSED BRANCH CIRCUIT DISCONNECT (SAFETY) SWITCHES WITH LAG TYPE FUSES FROM POWER SOURCE TO MACHINE. A SEPARATE GROUND WIRE MUST BE CONNECTED FROM DISCONNECT TO EQUIPMENT.

4 BASELINE "Z" IS THE REFERENCE FOR ALL VERTICAL DIMENSIONS. ON MACHINES WITH FIXED BASE PADS, BASELINE "Z" CORRESPONDS TO THE BOTTOM OF THE BASE PAD. ON MACHINES WITH ADJUSTABLE FEET, BASELINE "Z" CORRESPONDS TO THE BOTTOM OF THE FEET WHEN ADJUSTED SO THAT THE MACHINE IS AT ITS MINIMUM ACCEPTABLE HEIGHT. ON TRAVELING SHUTTLES, BASELINE "Z" CORRESPONDS TO THE BOTTOM OF THE BOTTOM RAIL. THE DISTANCE BETWEEN BASELINE "Z" AND THE FINISHED FLOOR WILL VARY AS REQUIRED TO ENSURE BASELINE "Z" IS HORIZONTAL AND ANY INTERFACING MACHINES REQUIRING GROUT ARE SET ON A MINIMUM 1"[25] THICK GROUT BED.

3 USE REFERENCE LINES "X", "Y", AND "Z" TO LOCATE ALL SERVICE CONNECTIONS.

2 NUMBERS IN BRACKETS [] DENOTE DIMENSIONS IN MILLIMETERS.

1 ALL DIMENSIONS SHOWN ARE APPROXIMATE, SUBJECT TO NORMAL MANUFACTURING TOLERANCES, AND TO OCCASIONAL CHANGES WITHOUT NOTICE THROUGH REDESIGN AND/OR RELOCATION OF COMPONENTS, ETC. DO NOT USE FOR CONSTRUCTION UNLESS CERTIFIED, AND IN NO EVENT PRE-PIPE CLOSER THAN FIVE FEET FROM MACHINE. FACTORY MUST BE CONSULTED FOR DIMENSIONS IF MACHINE IS TO BE MOVED THROUGH NARROW OR LOW CORRIDORS OR OPENINGS.

ATTENTION
MOST REGULATORY AUTHORITIES (INCLUDING OSHA IN THE USA) HOLD THE OWNER/USER ULTIMATELY RESPONSIBLE TO MAINTAIN A SAFE WORKING ENVIRONMENT. ACCORDINGLY, THE OWNER/USER MUST RECOGNIZE ALL FORESEEABLE SAFETY HAZARDS, FURNISH SAFETY INSTRUCTIONS AND GUIDANCE TO ALL FORESEEABLE SAFETY HAZARDS, IN CONTACT WITH THE INSTALLATION, AND PROVIDE ALL NECESSARY ADDITIONAL SAFETY GUARDS, FENCES, RESTRAINTS, DEVICES, ETC., NOT FURNISHED BY THE EQUIPMENT MANUFACTURER OR VENDOR.

ATTENTION
THE FLOOR AND/OR OTHER SUPPORT COMPONENTS MUST HAVE SUFFICIENT STRENGTH (AND RIGIDITY WITH DUE CONSIDERATION FOR NATURAL OR RESONANT FREQUENCY THEREOF) TO WITHSTAND THE FULLY LOADED WEIGHT OF THE MACHINE INCLUDING THE GOODS, THE WATER, AND ANY REPEATED SINUSOIDAL (ROTATING) FORCES GENERATED DURING ITS OPERATION. WRITE THE FACTORY FOR ADDITIONAL MACHINE DATA FOR USE BY A COMPETENT SOIL AND/OR STRUCTURAL ENGINEER.

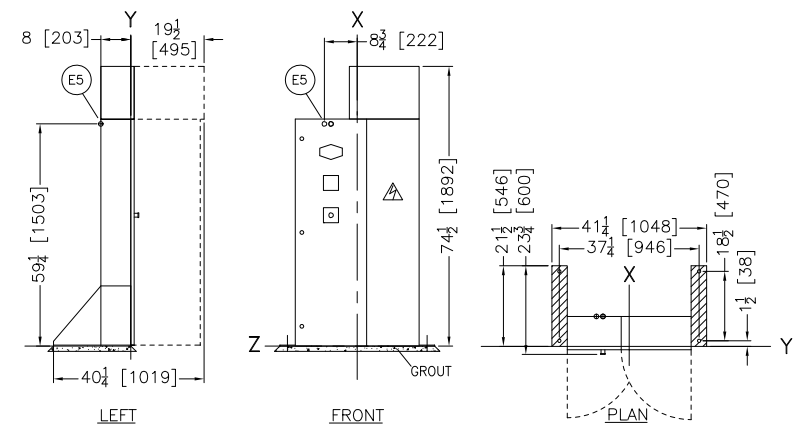
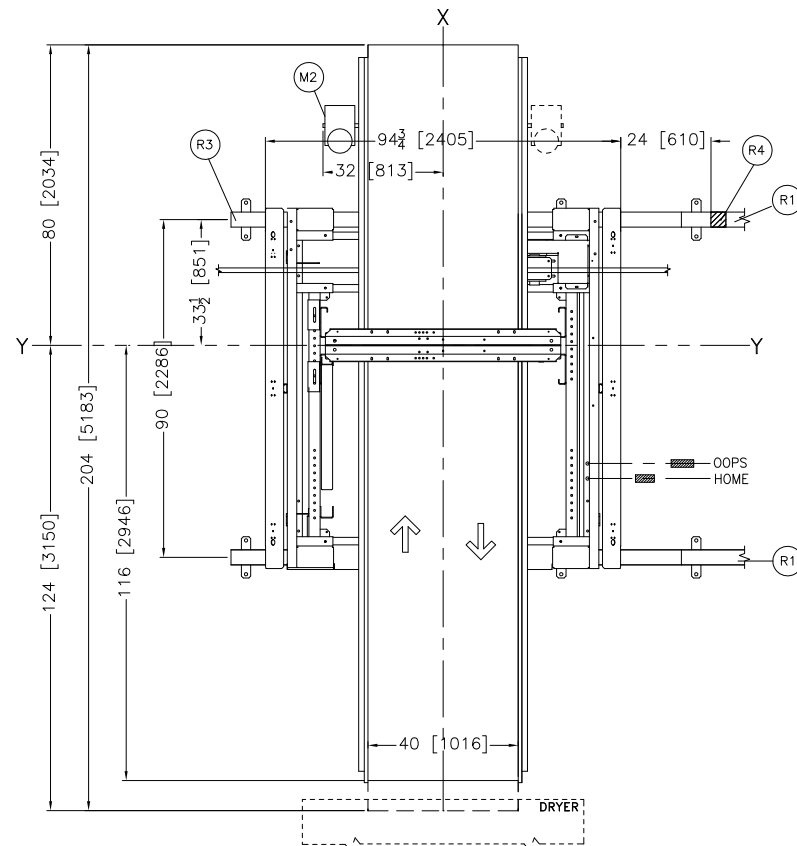
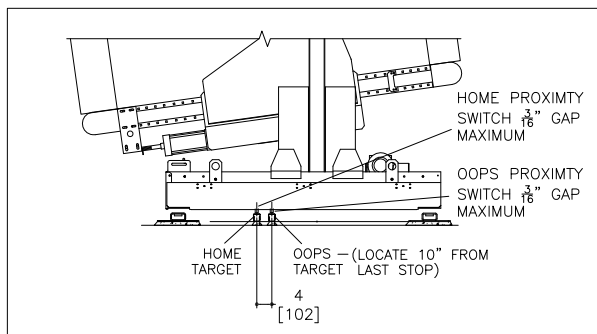
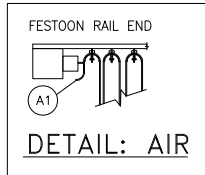
CG4010MS

MILNOR PELLERIN MILNOR CORPORATION
P.O. Box 400 Kenner, LA 70063, USA, Phone 504/467-9591, FAX 504/469-1849, Email: mktg@milnor.com

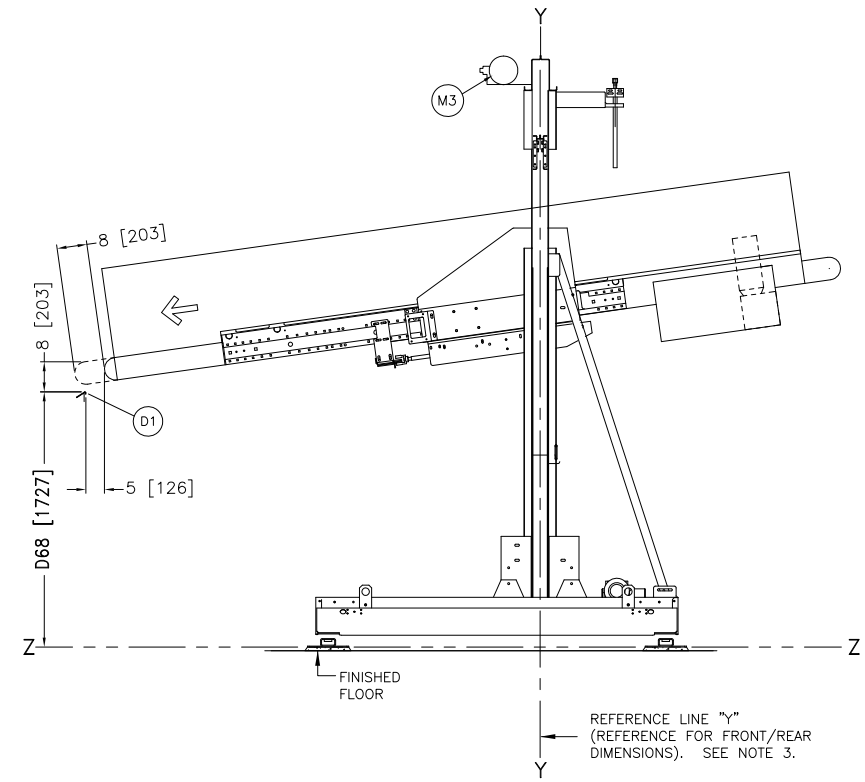
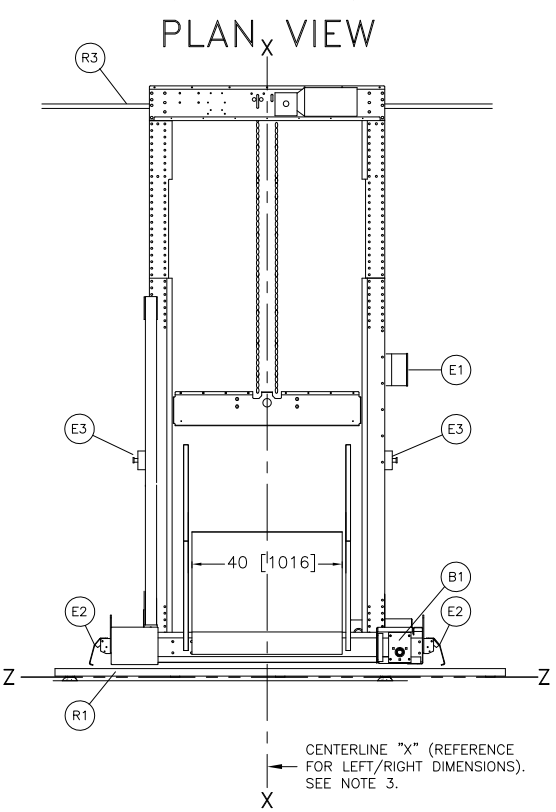
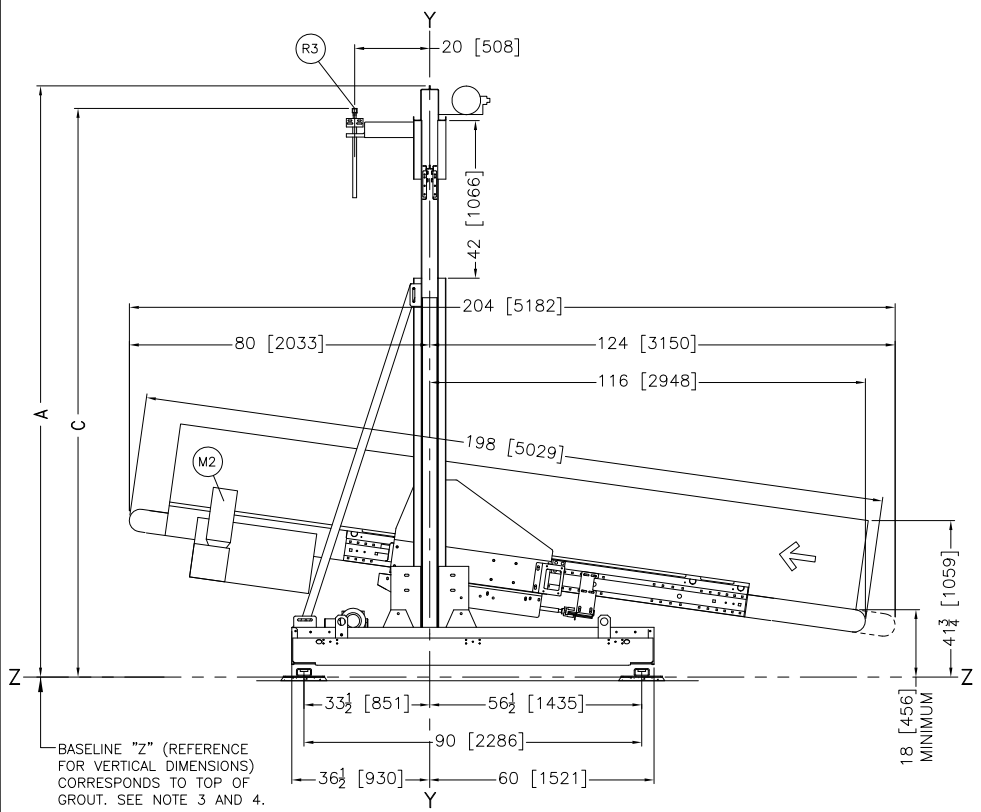
DWG# BDCG4010MSAE 2015492D

Scale: 0 0.5M 1M / INCHES 0 12 24 36

WHEN THIS DRYER PEDESTAL EXTENDER IS USED WITH DRYER 7676TG1/TS1		WHEN THIS DRYER PEDESTAL EXTENDER IS USED WITH DRYER 6458 & 6464TG1/TS1		WHEN THIS DRYER PEDESTAL EXTENDER IS USED WITH DRYER 5808TG1/TS1		WHEN THIS DRYER PEDESTAL EXTENDER IS USED WITH DRYER 58058TG2/TS1		USE THIS SIDE RAIL EXTENDER CG4016GS		CG4016GS DIMENSIONS				DIMENSION "D"		DIMENSION "D"	
										DIMENSION "A"		DIMENSION "C"		58XX DRYERS LOAD HEIGHT		6458, 6464 & 7676 DRYERS LOAD HEIGHT	
INCHES	mm	INCHES	mm	INCHES	mm	INCHES	mm	INCHES	mm	INCHES	mm	INCHES	mm	INCHES	mm	INCHES	mm
-7	-178	0	0	-	-	-	-	42	1067	157 1/2	4000	151	3835	69 1/2	1765	68	1727
-3 1/2	-89	3 1/2	89	-	-	0	0	45 1/2	1156	161	4089	154 1/2	3924	73	1854	71 1/2	1816
0	0	7	178	-	-	3 1/2	89	49	1245	164 1/2	4178	158	4013	76 1/2	1943	75	1905
3 1/2	89	10 1/2	267	0	0	7	178	52 1/2	1334	168	4267	161 1/2	4102	80	2032	78 1/2	1994
7	178	14	356	3 1/2	89	10 1/2	267	56	1422	171 1/2	4356	165	4191	83 1/2	2121	82	2083
14	356	21	533	10 1/2	267	17 1/2	445	63	1600	178 1/2	4534	172	4369	90 1/2	2299	89	2261
21	533	28	711	17 1/2	445	24 1/2	622	70	1778	185 1/2	4712	179	4547	97 1/2	2477	96	2438



REMOTE MOUNT SHUTTLE CONTROL BOX
SEE NOTE 10.



ITEM	LEGEND
R4	POSITIVE STOP
R3	FESTOON RAIL. RAIL SUPPLIED BY MILNOR AND MAY BE PRICED SEPARATELY. SEE PRICE LIST.
R1	FLOOR DRIVE RAILS. RAIL SUPPLIED BY MILNOR AND MAY BE PRICED SEPARATELY. SEE PRICE LIST.
M3	HOIST MOTOR AND WINCH.
M2	UNDER DRIVE, BELT MOTOR MAY BE ON LEFT OR RIGHT.
M1	DRIVE MOTOR, UNDER CART FRAME, NOT VISIBLE.
F1	FESTOON CABLE
E5	ELECTRICAL & CONTROL CABLE CONNECTIONS FOR REMOTE SHUTTLE CONTROL BOX
E3	EMERGENCY STOP BUTTON
E2	EMERGENCY STOP KICK PLATE
E1	JUNCTION BOX
D1	LOAD DOOR SLEEF
B1	CART FRAME WELDMENT
A1	COMPRESSED AIR 1/2" ID HOSE CONNECTION

NOTES !!
THIS DRAWING UTILIZES "THIRD ANGLE PROJECTION" RULES AS SHOWN.

NOTES
12 THE SHUTTLE NAME CONFIGURATION IS AS FOLLOWS:
CG = CART DRIVEN/TRANSLATE/ELEVATE
40 = BELT WIDTH IN INCHES
16 = LENGTH OF BED = 16'[5020]
G = 8" TO LOAD + 0" TO DISCHARGE
S = SINGLE BED

10 CONTROLS FOR THE SHUTTLE ARE CONTAINED IN THIS REMOTELY MOUNTED SHUTTLE CONTROL BOX WHICH MUST BE PLACED IN THE EQUIPMENT LAYOUT.

9 DIMENSION VARIES WITH HEIGHT OF EXTENDERS WHEN ADDED.

8 EMERGENCY STOPS ARE REQUIRED ON BOTH LEFT AND RIGHT SIDES OF THE SHUTTLE. A THIRD EMERGENCY STOP IS INSTALLED INTO THE DOOR OF THE REMOTE SHUTTLE CONTROL BOX.

7 AFTER MACHINE HAS BEEN COMMISSIONED, BELT MAY STRETCH SLIGHTLY REQUIRING ADJUSTMENT OF BELT ROLLERS AND SLIGHT LENGTHENING OF CONVEYOR.

6 AS OF THIS WRITING, THE MINIMUM CLEARANCE REQUIRED BY U.S. NATIONAL ELECTRIC CODES, FROM ELECTRIC BOX TO ANY OBJECT IS:
36 [914] IF OBJECT IS AN UNGROUNDED (INSULATED) WALL
42 [1067] IF OBJECT IS A GROUNDED WALL (ie. BARE CONCRETE, BRICK, ETC.)
48 [1219] IF OBJECT IS ANY LIVE PART.
CHECK LOCAL ELECTRIC CODES FOR FURTHER RESTRICTIONS.

5 CUSTOMER TO SUPPLY CIRCUIT BREAKER OR FUSED BRANCH CIRCUIT DISCONNECT (SAFETY) SWITCHES WITH LAG TYPE FUSES FROM POWER SOURCE TO MACHINE. A SEPARATE GROUND WIRE MUST BE CONNECTED FROM DISCONNECT TO EQUIPMENT.

4 BASELINE "Z" IS THE REFERENCE FOR ALL VERTICAL DIMENSIONS. ON MACHINES WITH FIXED BASE PADS, BASELINE "Z" CORRESPONDS TO THE BOTTOM OF THE BASE PAD. ON MACHINES WITH ADJUSTABLE FEET, BASELINE "Z" CORRESPONDS TO THE BOTTOM OF THE FEET WHEN ADJUSTED SO THAT THE MACHINE IS AT ITS MINIMUM ACCEPTABLE HEIGHT. ON TRAVELING SHUTTLES, BASELINE "Z" CORRESPONDS TO THE BOTTOM OF THE BOTTOM RAIL. THE DISTANCE BETWEEN BASELINE "Z" AND THE FINISHED FLOOR WILL VARY AS REQUIRED TO ENSURE BASELINE "Z" IS HORIZONTAL AND ANY INTERFACING MACHINES REQUIRING GROUT ARE SET ON A MINIMUM 1"[25] THICK GROUT BED.

3 USE REFERENCE LINES "X", "Y", AND "Z" TO LOCATE ALL SERVICE CONNECTIONS.

2 NUMBERS IN BRACKETS [] DENOTE DIMENSIONS IN MILLIMETERS.

1 ALL DIMENSIONS SHOWN ARE APPROXIMATE, SUBJECT TO NORMAL MANUFACTURING TOLERANCES, AND TO OCCASIONAL CHANGES WITHOUT NOTICE THROUGH REDESIGN AND/OR RELOCATION OF COMPONENTS, ETC. DO NOT USE FOR CONSTRUCTION UNLESS CERTIFIED, AND IN NO EVENT PRE-PIPE CLOSER THAN FIVE FEET FROM MACHINE. FACTORY MUST BE CONSULTED FOR DIMENSIONS IF MACHINE IS TO BE MOVED THROUGH NARROW OR LOW CORRIDORS OR OPENINGS.

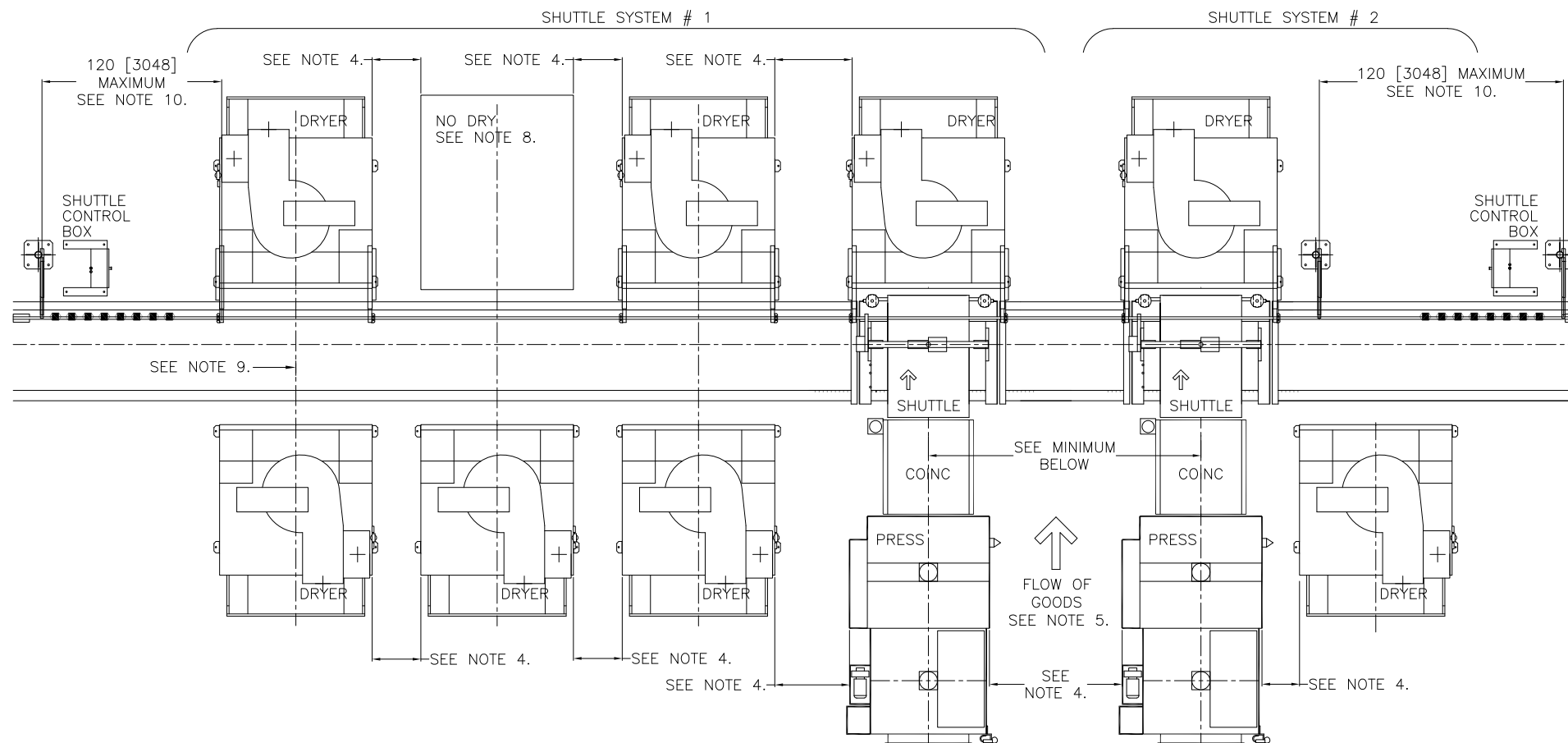
ATTENTION
MOST REGULATORY AUTHORITIES (INCLUDING OSHA IN THE USA) HOLD THE OWNER/USER ULTIMATELY RESPONSIBLE TO MAINTAIN A SAFE WORKING ENVIRONMENT. ACCORDINGLY, THE OWNER/USER MUST RECOGNIZE ALL FORESEEABLE SAFETY HAZARDS, FURNISH SAFETY INSTRUCTIONS AND GUIDANCE TO ALL PERSONNEL WHO MAY COME IN CONTACT WITH THE INSTALLATION, AND PROVIDE ALL NECESSARY ADDITIONAL SAFETY GUARDS, FENCES, RESTRAINTS, DEVICES, ETC., NOT FURNISHED BY THE EQUIPMENT MANUFACTURER OR VENDOR.

ATTENTION
THE FLOOR AND/OR OTHER SUPPORT COMPONENTS MUST HAVE SUFFICIENT STRENGTH (AND RIGIDITY WITH DUE CONSIDERATION FOR NATURAL OR RESONANT FREQUENCY THEREOF) TO WITHSTAND THE FULLY LOADED WEIGHT OF THE MACHINE INCLUDING THE GOODS, THE WATER, AND ANY REPEATED SINUSOIDAL (ROTATING) FORCES GENERATED DURING ITS OPERATION. WRITE THE FACTORY FOR ADDITIONAL MACHINE DATA FOR USE BY A COMPETENT SOIL AND/OR STRUCTURAL ENGINEER.

CG4016GS

DWG# BDCG4016GSAE 2016494D

MILNOR PELLERIN MILNOR CORPORATION
P.O. Box 400 Kenner, LA 70063, USA, Phone 504/467-9591, FAX 504/469-1849, Email: mktg@milnor.com

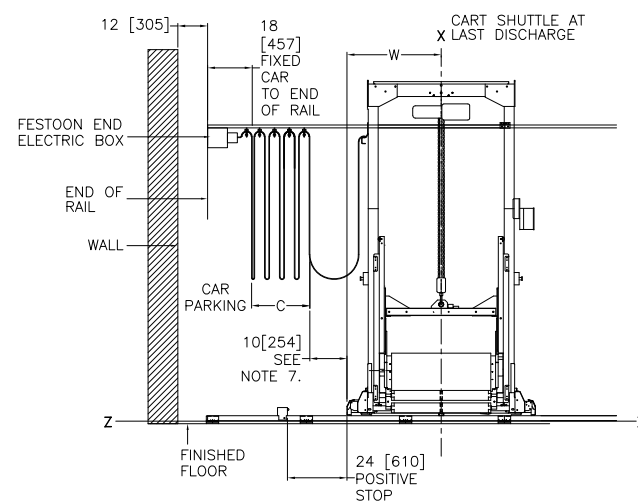


PLAN VIEW - EXAMPLE COMPONENT PLACEMENT

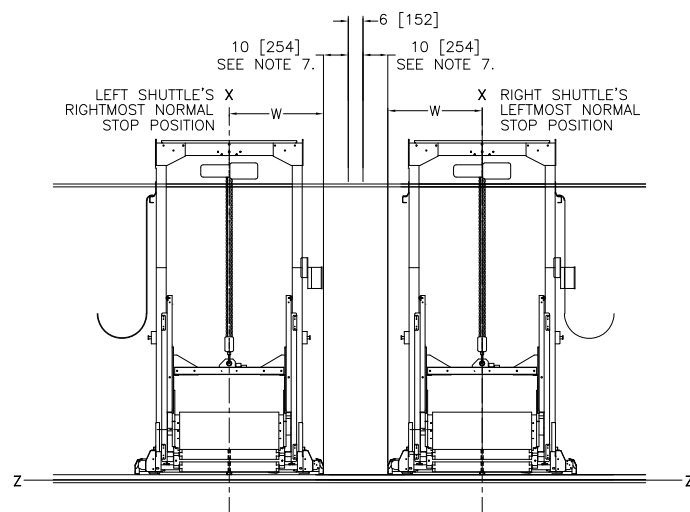
HOW TO CALCULATE THE PARKING LENGTH FOR FESTOON CARS:

$$C = N \times 8'' [203]$$

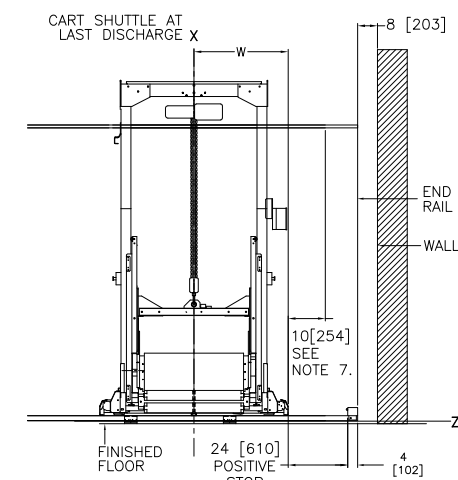
N = LENGTH OF RAIL
120'' [3048]
N = # OF FESTOON RAILS
N = # OF FESTOON CARS



MINIMUM DIMENSIONS FESTOON END TO END OF RAIL & WALL



MINIMUM DIMENSIONS BETWEEN TWO CART SHUTTLES WHEN FESTOONING FROM OPPOSITE ENDS



MINIMUM DIMENSIONS NON-FESTOON END TO END OF RAIL & WALL

W = WIDTH DIMENSION FROM "X" TO OUTERMOST PART OF SHUTTLE.
(SEE DRAWING OF YOUR SPECIFIC SHUTTLE FOR THIS DIMENSION)

- NOTES**
- FESTOON RAIL FREESTAND SUPPORTS, DRYER MOUNTED SUPPORTS, OR CEILING MOUNTED RAIL SUPPORTS MUST BE LOCATED A MAXIMUM OF 120 [3048] APART ALONG THE ENTIRE LENGTH OF RAIL.
 - IT IS PREFERRED THAT LOAD AND DISCHARGE POSITIONS ACROSS FROM EACH OTHER ON THE RAIL BE EXACTLY ALIGNED. IF DISCHARGE POSITIONS ARE NOT ALIGNED, BUT ARE VERY CLOSE, CONSULT MILNOR FACTORY.
 - WHENEVER POSSIBLE, NO-DRY POSITIONS SHOULD BE ALLOCATED THE SAME SPACE AND CLEARANCE AS A DRYER TO ACCOMMODATE THE FUTURE ADDITION OF A DRYER.
 - TO ACCOMMODATE THE SHUTTLE "OOPS SWITCH" AND THE POSITIVE STOPS, THE TOTAL RAIL LENGTH AT EACH END MUST PERMIT THE SHUTTLE TO TRAVEL AT LEAST 10' [254] BEYOND ITS LAST NORMAL STOP PLACE. THERE MUST BE SUFFICIENT ADDITIONAL RAIL LENGTH TO PARK ALL THE FESTOON CABLE SUPPORT CARS. DIMENSION "C". FESTOON CARS REQUIRE 6" [152] EACH, SEE FORMULA.
 - ALL MINIMUM DIMENSIONS ARE ABSOLUTE MINIMUMS AND DO NOT NECESSARILY ALLOW FOR EASE OF MAINTENANCE. GREATER CLEARANCE SHOULD BE ALLOWED WHERE DESIRED.
 - ALL REFERENCES TO LEFT AND RIGHT ARE, WHEN VIEWED, IN THE DIRECTION OF THE FLOW OF GOODS FROM THE PRESS ONTO THE SHUTTLE.
 - AS OF THIS WRITING, THE MINIMUM CLEARANCE REQUIRED BY U.S. NATIONAL ELECTRIC CODES, FROM ELECTRIC BOX TO ANY OBJECT IS:
36 [914] IF OBJECT IS AN UNGROUNDED (INSULATED) WALL.
42 [1067] IF OBJECT IS A GROUNDED WALL (i.e. BARE CONCRETE, BRICK, ETC.)
48 [1219] IF OBJECT IS ANY LIVE PART.
CHECK LOCAL ELECTRIC CODES FOR FURTHER RESTRICTIONS.
 - USE REFERENCE LINES "X", "Y", AND "Z" TO LOCATE ALL SERVICE CONNECTIONS.
 - NUMBERS IN BRACKETS [] DENOTE DIMENSIONS IN MILLIMETERS.
 - ALL DIMENSIONS SHOWN ARE APPROXIMATE. SUBJECT TO NORMAL MANUFACTURING TOLERANCES, AND TO OCCASIONAL CHANGES WITHOUT NOTICE THROUGH REDESIGN AND/OR RELOCATION OF COMPONENTS, ETC. DO NOT USE FOR CONSTRUCTION UNLESS CERTIFIED, AND IN NO EVENT PRE-PIPE CLOSER THAN FIVE FEET FROM MACHINE. FACTORY MUST BE CONSULTED FOR DIMENSIONS IF MACHINE IS TO BE MOVED THROUGH NARROW OR LOW CORRIDORS OR OPENINGS.

ATTENTION
MOST REGULATORY AUTHORITIES (INCLUDING OSHA IN THE USA) HOLD THE OWNER/USER ULTIMATELY RESPONSIBLE TO MAINTAIN A SAFE WORKING ENVIRONMENT. ACCORDINGLY, THE OWNER/USER MUST RECOGNIZE ALL FORESEEABLE SAFETY HAZARDS, FURNISH SAFETY INSTRUCTIONS AND GUIDANCE TO ALL PERSONNEL WHO MAY COME IN CONTACT WITH THE INSTALLATION, AND PROVIDE ALL NECESSARY ADDITIONAL SAFETY GUARDS, FENCES, RESTRAINTS, DEVICES, ETC., NOT FURNISHED BY THE EQUIPMENT MANUFACTURER OR VENDOR.

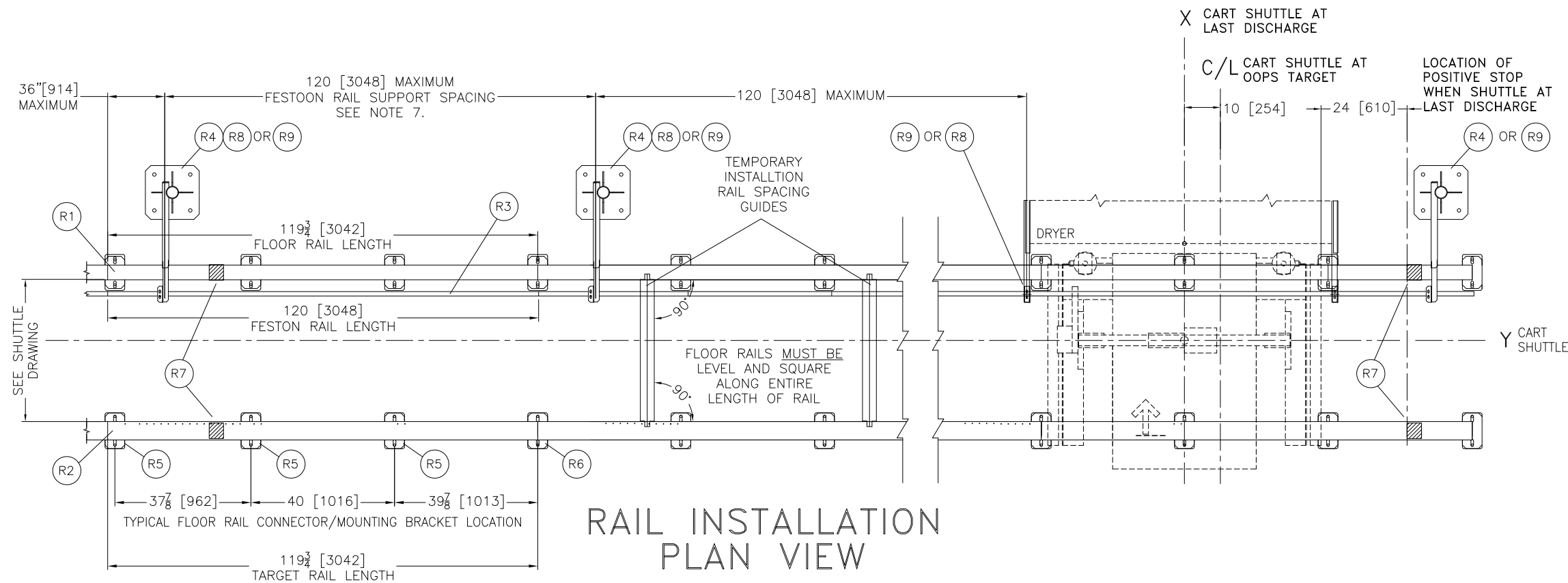
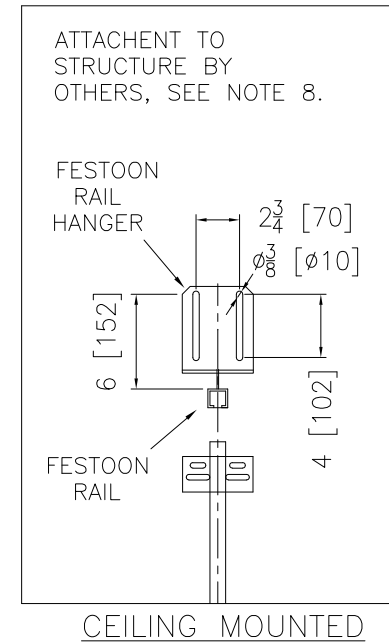
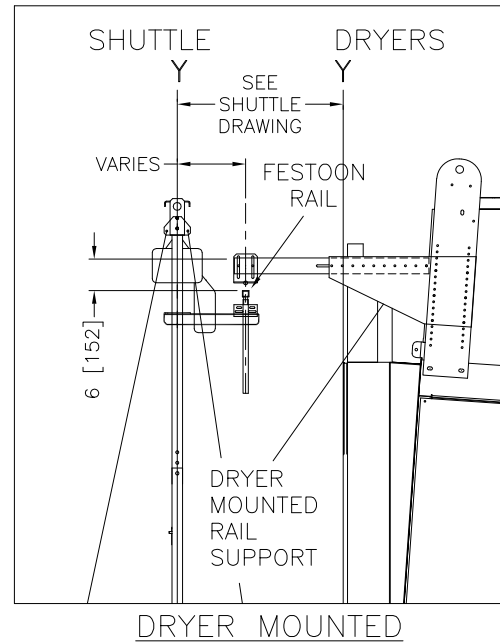
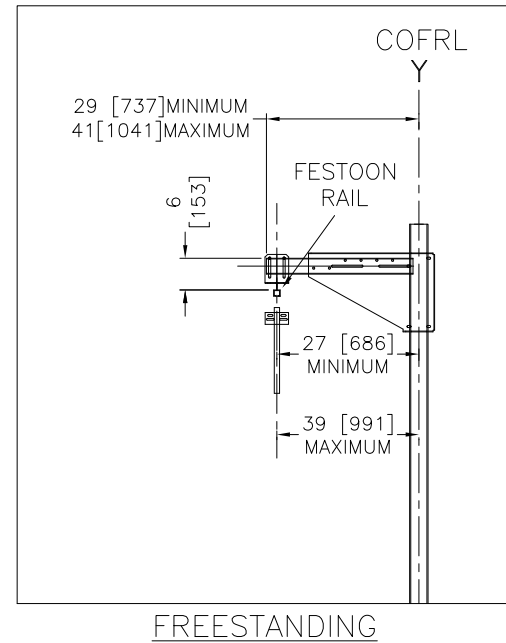
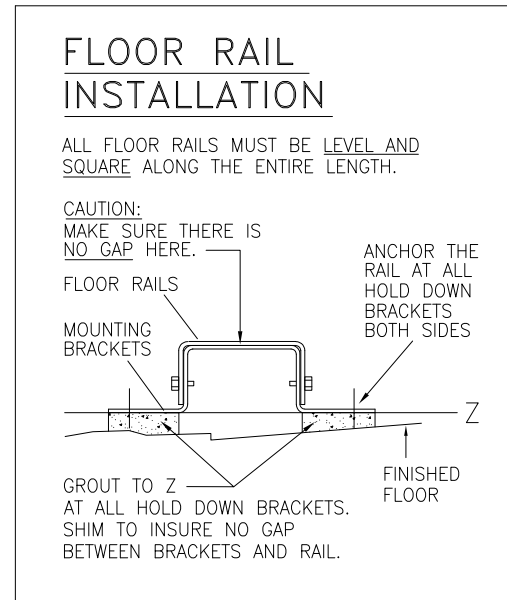
ATTENTION
THE FLOOR AND/OR OTHER SUPPORT COMPONENTS MUST HAVE SUFFICIENT STRENGTH (AND RIGIDITY WITH DUE CONSIDERATION FOR NATURAL OR RESONANT FREQUENCY THEREOF) TO WITHSTAND THE FULLY LOADED WEIGHT OF THE MACHINE INCLUDING THE GOODS, THE WATER, AND ANY REPEATED SINUSOIDAL (ROTATING) FORCES GENERATED DURING ITS OPERATION. WRITE THE FACTORY FOR ADDITIONAL MACHINE DATA FOR USE BY A COMPETENT SOIL AND/OR STRUCTURAL ENGINEER.

MINIMUM CLEARANCE-CART SHUTTLE RAIL

NOT TO SCALE DWG# BDCTRILAE 2020302D

MILNOR PELLERIN MILNOR CORPORATION
P.O. Box 400 Kenner, LA 70063, USA, Phone 504/467-9591, FAX 504/468-3094, Email: milnorinfo@milnor.com

FESTOON RAIL SUPPORTS



R9	CEILING MOUNTED RAIL SUPPORT, BY OTHERS.
R8	DRYER MOUNTER RAIL SUPPORT
R7	POSITIVE STOP
R6	FLOOR RAIL CONNECTORS/MOUNTING BRACKETS
R5	FLOOR RAIL MOUNTING BRACKETS
R4	FREESTANDING FESTOON RAIL SUPPORT
R3	FESTOON RAIL
R2	TARGET RAIL
R1	FLOOR RAIL
ITEM	LEGEND

- #### NOTES
- CEILING MOUNTED RAIL SUPPORTS MAY BE USED TO SUPPORT RAIL FROM CEILING. FIELD INNOVATION IS REQUIRED, INCLUDING VERIFICATION BY COMPETENT OTHER PERSONS THAT THE CEILING IS ADEQUATE TO SUPPORT THE LOAD. THIS IS NOT THE RESPONSIBILITY OF PMC.
 - FESTOON RAIL FREESTAND SUPPORTS, DRYER MOUNTED SUPPORTS, OR CEILING MOUNTED RAIL SUPPORTS MUST BE LOCATED A MAXIMUM OF 120 [3048] APART ALONG THE ENTIRE LENGTH OF RAIL.
 - AS OF THIS WRITING, THE MINIMUM CLEARANCE REQUIRED BY U.S. NATIONAL ELECTRIC CODES, FROM ELECTRIC BOX TO ANY OBJECT IS:
36 [914] IF OBJECT IS AN UNGROUNDED (INSULATED) WALL
42 [1067] IF OBJECT IS A GROUNDED WALL (i.e. BARE CONCRETE, BRICK, ETC.)
48 [1219] IF OBJECT IS ANY LIVE PART.
CHECK LOCAL ELECTRIC CODES FOR FURTHER RESTRICTIONS.
 - CUSTOMER TO SUPPLY CIRCUIT BREAKER OR FUSED BRANCH CIRCUIT DISCONNECT (SAFETY) SWITCHES WITH LAG TYPE FUSES FROM POWER SOURCE TO MACHINE. A SEPARATE GROUND WIRE MUST BE CONNECTED FROM DISCONNECT TO EQUIPMENT.
 - BASELINE "Z" IS THE REFERENCE FOR ALL VERTICAL DIMENSIONS. ON MACHINES WITH FIXED BASE PADS, BASELINE "Z" CORRESPONDS TO THE BOTTOM OF THE BASE PAD. ON MACHINES WITH ADJUSTABLE FEET, BASELINE "Z" CORRESPONDS TO THE BOTTOM OF THE FEET WHEN ADJUSTED SO THAT THE MACHINE IS AT ITS MINIMUM ACCEPTABLE HEIGHT. ON TRAVERSING SHUTTLES, BASELINE "Z" CORRESPONDS TO THE BOTTOM OF THE BOTTOM RAIL. THE DISTANCE BETWEEN BASELINE "Z" AND THE FINISHED FLOOR WILL VARY AS REQUIRED TO ENSURE BASELINE "Z" IS HORIZONTAL AND ANY INTERFACING MACHINES REQUIRING GROUT ARE SET ON A MINIMUM 1 [25] THICK GROUT BED.
 - USE REFERENCE LINES "X", "Y", AND "Z" TO LOCATE ALL SERVICE CONNECTIONS.
 - NUMBERS IN BRACKETS [] DENOTE DIMENSIONS IN MILLIMETERS.
 - ALL DIMENSIONS SHOWN ARE APPROXIMATE, SUBJECT TO NORMAL MANUFACTURING TOLERANCES, AND TO OCCASIONAL CHANGES WITHOUT NOTICE THROUGH REDESIGN AND/OR RELOCATION OF COMPONENTS, ETC. DO NOT USE FOR CONSTRUCTION UNLESS CERTIFIED, AND IN NO EVENT PRE-PIPE CLOSER THAN FIVE FEET FROM MACHINE. FACTORY MUST BE CONSULTED FOR DIMENSIONS IF MACHINE IS TO BE MOVED THROUGH NARROW OR LOW CORRIDORS OR OPENINGS.
- #### ATTENTION
- MOST REGULATORY AUTHORITIES (INCLUDING OSHA IN THE USA) HOLD THE OWNER/USER ULTIMATELY RESPONSIBLE TO MAINTAIN A SAFE WORKING ENVIRONMENT. ACCORDINGLY, THE OWNER/USER MUST RECOGNIZE ALL FORESEEABLE SAFETY HAZARDS, FURNISH SAFETY INSTRUCTIONS AND GUIDANCE TO ALL PERSONNEL WHO MAY COME IN CONTACT WITH THE INSTALLATION, AND PROVIDE ALL NECESSARY ADDITIONAL SAFETY GUARDS, FENCES, RESTRAINTS, DEVICES, ETC., NOT FURNISHED BY THE EQUIPMENT MANUFACTURER OR VENDOR.
- #### ATTENTION
- THE FLOOR AND/OR OTHER SUPPORT COMPONENTS MUST HAVE SUFFICIENT STRENGTH (AND RIGIDITY WITH DUE CONSIDERATION FOR NATURAL OR RESONANT FREQUENCY THEREOF) TO WITHSTAND THE FULLY LOADED WEIGHT OF THE MACHINE INCLUDING THE GOODS, THE WATER, AND ANY REPEATED SINUSOIDAL (ROTATING) FORCES GENERATED DURING ITS OPERATION. WRITE THE FACTORY FOR ADDITIONAL MACHINE DATA FOR USE BY A COMPETENT SOIL AND/OR STRUCTURAL ENGINEER.

CART RAIL INSTALLATION

DWG# BDCTRILAB 2020302D

MILNOR PELLERIN MILNOR CORPORATION
P.O. Box 400 Kenner, LA 70063, USA, Phone 504/467-9591, FAX 504/468-3094, Email: milnorinfo@milnor.com