

Published Manual Number/ECN: MPI3010GAE/2006145A

- Publishing System: TPAS
- Access date: 4/6/2006
- Document ECN's: Latest Available



Installation and Service— 3010/3015 G5E,G5X Washer Extractor



**Read the
separate
safety
manual
before
installing,
operating,
or servicing**



Please Read

About the Manual Identifying Information on the Cover

The front cover displays pertinent identifying information for this manual. Most important, are the published manual number (part number) /ECN (date code). Generally, when a replacement manual is furnished, it will have the same published manual number, but the latest available ECN. This provides the user with the latest information applicable to his machine. Similarly all documents comprising the manual will be the latest available as of the date the manual was printed, **even though older ECN dates for those documents may be listed in the table of contents.**

When communicating with the Milnor factory regarding this manual, please also provide the other identifying information shown on the cover, including the publishing system, access date, and whether the document ECN's are the latest available or exact.

References to Yellow Troubleshooting Pages

This manual may contain references to "yellow pages." Although the pages containing troubleshooting procedures are no longer printed on yellow paper, troubleshooting instructions, if any, will be contained in the easily located "Troubleshooting" chapter or section. See the table of contents.

Trademarks of Pellerin Milnor Corporation

The following, some of which may be used in this manual, are trademarks of Pellerin Milnor Corporation:

Ampsaver [®]	Dye-Extractor [®]	Gear Guardian [®]	Milnet [®]	Staph-Guard [®]
Autolint [®]	Dyextractor [®]	Hands-Off [®]	Milnor [®]	System 4 [®]
Auto-Purge [®]	E-P Express [®]	Hydro-Cushion [®]	Miltrac	System 7 [®]
Autovac	E-P OneTouch [®]	Mildata [®]	Miltron	Totaltrol [®]
CBW [®]	E-P Plus [®]			

Comments and Suggestions

Help us to improve this manual by sending your comments to:

Pellerin Milnor Corporation
Attn: Technical Publications
P. O. Box 400
Kenner, LA 70063-0400

Fax: (504) 469-1849

Table of Contents
for MPI3010GAE/2006145A
3010/3015 G5E,G5X Washer Extractor

Page	Description	Document/ECN
1	Warranty	BMP720097/92732A
3	How to Order Parts	BMP720097R/72332A
4	Safety—Rigid Washer Extractors	BIUUUS27/20051111
9	Guards & Covers	BMP040011/2004055V
11	About the Forces Transmitted by Milnor Washer-Extractors	BIWUUI02/20001108
13	Glossary of Tag Illustrations-30" G, T and V style WE	MSIUUMTGAE/2004072V
18	Avoiding Damage from Allied Remote Chemical Delivery Systems	BIWUUI03/20030306
23	Handling and Setting Procedure for Rigid Mount W-E's	BIRUUI01/20031001
26	Service Connections	BIRQVI01/20050228
29	Section 1: Service and Maintenance	
30	Preventive Maintenance	BIRQUM01/20050302
34	Fastener Torque Requirements	MSSM0101CE/9906AV
53	Baldor Motor Maintenance	MSSM0274AE/9731AV
57	Section 2: Drive Assemblies	
58	Drive Chart 3010 & 3015 G5E,G5X	BMP040004/2004055V
59	Motor Mount	BMP040005/2004055V
61	Clutch Brake	BMP020054/2004103V
63	Section 3: Bearing Assemblies	
64	Shell & Cylinder Installation	BMP040007/2004055V
66	Bearing Assembly and Installation	BMP040006/2005171V
67	Section 4: Shell and Door Assemblies	
68	Shellfront Assembly, Conduit, & Interlock	BMP920024/2004055V
70	Door Assembly	BMP020002/2004055V
72	Interlock Assembly	BMP020058/2005086V
77	Section 5: Control and Sensing	
78	Level Switches	BMP040013/2004055V
79	Vibration Safety Switch Adjustments	MSSMA408BE/9273BV
81	Vibration Safety Switch	BMP040014/2004055V
83	Section 6: Chemical Supply	
84	Peristaltic Supply Box	BMP000046/2004055V
85	Soap Chute Installation	BMP000040/2004055V
87	Section 7: Water and Drain	
88	Schematic Symbols Key	BMP920008/2000302V
89	Water Schematics	BMP040012/2004055V
90	Water Inlet Assemblies with Peristaltic Supply 3010& 3015 G5E,G5X	BMP040009/2004055V
92	Drain Sump Installation	BMP920014/2004055V

Table of Contents, cont.

Page	Description	Document/ECN
93	Drain Valve Installation	BMP020057/2004055V
95	3" Electric Drain Valve	BMP920017/2002044V
97	Section 8: Dimensional Drawings	
99	Dimensional Drawing - 3010G5E,G5X	BD3010G5AE/2004275D
101	Dimensional Drawing - 3015G5E,G5X	BD3015G5AE/2004275D

PELLERIN MILNOR CORPORATION

LIMITED STANDARD WARRANTY

We warrant to the original purchaser that MILNOR machines including electronic hardware/software (hereafter referred to as "equipment"), will be free from defects in material and workmanship for a period of one year from the date of shipment from our factory with no operating hour limitation. This warranty is contingent upon the equipment being installed, operated and serviced as specified in the operating manual supplied with the equipment, and operated under normal conditions by competent operators.

Providing we receive written notification of a warranted defect within 30 days of its discovery, we will – at our option – repair or replace the defective part or parts, FOB our factory. We retain the right to require inspection of the parts claimed defective in our factory prior to repairing or replacing same. We will not be responsible, or in any way liable, for unauthorized repairs or service to our equipment, and this warranty shall be void if the equipment is repaired or altered in any way without MILNOR's written consent.

Parts which require routine replacement due to normal wear – such as gaskets, contact points, brake and clutch linings and similar parts – are not covered by this warranty, nor are parts damaged by exposure to weather or to chemicals.

We reserve the right to make changes in the design and/or construction of our equipment (including purchased components) without obligation to change any equipment previously supplied.

ANY SALE OR FURNISHING OF ANY EQUIPMENT BY MILNOR IS MADE ONLY UPON THE EXPRESS UNDERSTANDING THAT MILNOR MAKES NO EXPRESSED OR IMPLIED WARRANTIES OF MERCHANTABILITY OR FITNESS FOR ANY PARTICULAR USE OR PURPOSE. MILNOR WILL NOT BE RESPONSIBLE FOR ANY COSTS OR DAMAGES ACTUALLY INCURRED OR REQUIRED AS A RESULT OF: THE FAILURE OF ANY OTHER PERSON OR ENTITY TO PERFORM ITS RESPONSIBILITIES, FIRE OR OTHER HAZARD, ACCIDENT, IMPROPER STORAGE, MISUSE, NEGLIGENCE, POWER OR ENVIRONMENTAL CONTROL MALFUNCTIONS, DAMAGE FROM LIQUIDS, OR ANY OTHER CAUSE BEYOND THE NORMAL RANGE OF USE. REGARDLESS OF HOW CAUSED, IN NO EVENT SHALL MILNOR BE LIABLE FOR SPECIAL, INDIRECT, PUNITIVE, LIQUIDATED, OR CONSEQUENTIAL COSTS OR DAMAGES, OR ANY COSTS OR DAMAGES WHATSOEVER WHICH EXCEED THE PRICE PAID TO MILNOR FOR THE EQUIPMENT IT SELLS OR FURNISHES.

WE NEITHER ASSUME, NOR AUTHORIZE ANY EMPLOYEE OR OTHER PERSON TO ASSUME FOR US, ANY OTHER RESPONSIBILITY AND/OR LIABILITY IN CONNECTION WITH THE SALE OR FURNISHING OF OUR EQUIPMENT TO ANY BUYER.

BMP720097
92732A

How to order repair parts

Repair parts may be ordered either from the authorized dealer who sold you this machine, or directly from the MILNOR factory. In most cases, your dealer will have these parts in stock.

When ordering parts, please be sure to give us the following information:

1. Model and serial number of the machine for which the parts are required
2. Part number
3. Name of the part
4. Quantity needed
5. Method of shipment desired
6. In correspondence regarding motors or electrical controls, please include all nameplate data, including wiring diagram number and the make or manufacturer of the motor or controls.

All parts will be shipped C.O.D. transportation charges collect only.

Please read this manual

It is strongly recommended that you read the installation and operating manual before attempting to install or operate your machine. We suggest that this manual be kept in your business office so that it will not become lost.

PELLERIN MILNOR CORPORATION

P.O. BOX 400, KENNER, LA., 70063-0400, U.S.A.

FAX: Administration 504/468-9307, Engineering 504/469-1849, Service 504/469-9777

BMP720097R
72332A

Safety—Rigid Washer Extractors

1. General Safety Requirements—Vital Information for Management Personnel [Document BIUUUS04]

Incorrect installation, neglected preventive maintenance, abuse, and/or improper repairs, or changes to the machine can cause unsafe operation and personal injuries, such as multiple fractures, amputations, or death. The owner or his selected representative (owner/user) is responsible for understanding and ensuring the proper operation and maintenance of the machine. The owner/user must familiarize himself with the contents of all machine instruction manuals. The owner/user should direct any questions about these instructions to a Milnor® dealer or the Milnor® Service department.

Most regulatory authorities (including OSHA in the USA and CE in Europe) hold the owner/user ultimately responsible for maintaining a safe working environment. Therefore, the owner/user must do or ensure the following:

- recognize all foreseeable safety hazards within his facility and take actions to protect his personnel, equipment, and facility;
- work equipment is suitable, properly adapted, can be used without risks to health or safety, and is adequately maintained;
- where specific hazards are likely to be involved, access to the equipment is restricted to those employees given the task of using it;
- only specifically designated workers carry out repairs, modifications, maintenance, or servicing;
- information, instruction, and training is provided;
- workers and/or their representatives are consulted.

Work equipment must comply with the requirements listed below. The owner/user must verify that installation and maintenance of equipment is performed in such a way as to support these requirements:

- control devices must be visible, identifiable, and marked; be located outside dangerous zones; and not give rise to a hazard due to unintentional operation;
- control systems must be safe and breakdown/damage must not result in danger;
- work equipment is to be stabilized;
- protection against rupture or disintegration of work equipment;
- guarding, to prevent access to danger zones or to stop movements of dangerous parts before the danger zones are reached. Guards to be robust; not give rise to any additional hazards; not be easily removed or rendered inoperative; situated at a sufficient distance from the danger zone; not restrict view of operating cycle; allow fitting, replacing, or maintenance by restricting access to relevant area and without removal of guard/protection device;
- suitable lighting for working and maintenance areas;
- maintenance to be possible when work equipment is shut down. If not possible, then protection measures to be carried out outside danger zones;
- work equipment must be appropriate for preventing the risk of fire or overheating; discharges of gas, dust, liquid, vapor, other substances; explosion of the equipment or substances in it.

- 1.1. **Laundry Facility**—Provide a supporting floor that is strong and rigid enough to support—with a reasonable safety factor and without undue or objectionable deflection—the weight of the fully loaded machine and the forces transmitted by it during operation. Provide sufficient clearance for machine movement. Provide any safety guards, fences, restraints, devices, and verbal and/or posted restrictions necessary to prevent personnel, machines, or other moving machinery from accessing the machine or its path. Provide adequate ventilation to carry away heat and vapors. Ensure service connections to installed machines meet local and national safety standards, especially regarding the electrical disconnect (see the National Electric Code). Prominently post safety information, including signs showing the source of electrical disconnect.
- 1.2. **Personnel**—Inform personnel about hazard avoidance and the importance of care and common sense. Provide personnel with the safety and operating instructions that apply to them. Verify that personnel use proper safety and operating procedures. Verify that personnel understand and abide by the warnings on the machine and precautions in the instruction manuals.
- 1.3. **Safety Devices**—Ensure that no one eliminates or disables any safety device on the machine or in the facility. Do not allow machine to be used with any missing guard, cover, panel or door. Service any failing or malfunctioning device before operating the machine.
- 1.4. **Hazard Information**—Important information on hazards is provided on the machine safety placards, in the Safety Guide, and throughout the other machine manuals. **Placards must be kept clean so that the information is not obscured. They must be replaced immediately if lost or damaged. The Safety Guide and other machine manuals must be available at all times to the appropriate personnel.** See the machine service manual for safety placard part numbers. Contact the Milnor Parts department for replacement placards or manuals.
- 1.5. **Maintenance**—Ensure the machine is inspected and serviced in accordance with the norms of good practice and with the preventive maintenance schedule. Replace belts, pulleys, brake shoes/disks, clutch plates/tires, rollers, seals, alignment guides, etc. before they are severely worn. Immediately investigate any evidence of impending failure and make needed repairs (e.g., cylinder, shell, or frame cracks; drive components such as motors, gear boxes, bearings, etc., whining, grinding, smoking, or becoming abnormally hot; bending or cracking of cylinder, shell, frame, etc.; leaking seals, hoses, valves, etc.) Do not permit service or maintenance by unqualified personnel.

2. **Safety Alert Messages—Internal Electrical and Mechanical Hazards** [Document BIUUUS11]

The following are instructions about hazards inside the machine and in electrical enclosures.



WARNING 1: Electrocution and Electrical Burn Hazards—Contact with electric power can kill or seriously injure you. Electric power is present inside the cabinetry unless the main machine power disconnect is off.

- Do not unlock or open electric box doors.
- Do not remove guards, covers, or panels.
- Do not reach into the machine housing or frame.
- Keep yourself and others off of machine.
- Know the location of the main machine disconnect and use it in an emergency to remove all electric power from the machine.



WARNING 2: Entangle and Crush Hazards—Contact with moving components normally isolated by guards, covers, and panels, can entangle and crush your limbs. These components move automatically.

- Do not remove guards, covers, or panels.
- Do not reach into the machine housing or frame.
- Keep yourself and others off of machine.
- Know the location of all emergency stop switches, pull cords, and/or kick plates and use them in an emergency to stop machine motion.

3. Safety Alert Messages—Cylinder and Processing Hazards

[Document BIUUUS13]

The following are instructions about hazards related to the cylinder and laundering process.



DANGER 3: Entangle and Sever Hazards—Contact with goods being processed can cause the goods to wrap around your body or limbs and dismember you. The goods are normally isolated by the locked cylinder door.

- Do not attempt to open the door or reach into the cylinder until the cylinder is stopped.
- Do not touch goods inside or hanging partially outside the turning cylinder.
- Do not operate the machine with a malfunctioning door interlock.
- Know the location of all emergency stop switches, pull cords, and/or kick plates and use them in an emergency to stop machine motion.
- Know the location of the main machine disconnect and use it in an emergency to remove all electric power from the machine.



WARNING 4: Crush Hazards—Contact with the turning cylinder can crush your limbs. The cylinder will repel any object you try to stop it with, possibly causing the object to strike or stab you. The turning cylinder is normally isolated by the locked cylinder door.

- Do not attempt to open the door or reach into the cylinder until the cylinder is stopped.
- Do not place any object in the turning cylinder.
- Do not operate the machine with a malfunctioning door interlock.



WARNING 5: Confined Space Hazards—Confinement in the cylinder can kill or injure you. Hazards include but are not limited to panic, burns, poisoning, suffocation, heat prostration, biological contamination, electrocution, and crushing.

- Do not attempt unauthorized servicing, repairs, or modification.



WARNING 6: Explosion and Fire Hazards—Flammable substances can explode or ignite in the cylinder, drain trough, or sewer. The machine is designed for washing with water, not any other solvent. Processing can cause solvent-containing goods to give off flammable vapors.

- Do not use flammable solvents in processing.
- Do not process goods containing flammable substances. Consult with your local fire department/public safety office and all insurance providers.

4. Safety Alert Messages—Unsafe Conditions [Document BIUUUS14]

4.1. Damage and Malfunction Hazards

4.1.1. Hazards Resulting from Inoperative Safety Devices



DANGER 7: Entangle and Sever Hazards—Cylinder door interlock—Operating the machine with a malfunctioning door interlock can permit opening the door when the cylinder is turning and/or starting the cycle with the door open, exposing the turning cylinder.

- Do not operate the machine with any evidence of damage or malfunction.



WARNING 8: Multiple Hazards—Operating the machine with an inoperative safety device can kill or injure personnel, damage or destroy the machine, damage property, and/or void the warranty.

- Do not tamper with or disable any safety device or operate the machine with a malfunctioning safety device. Request authorized service.



WARNING 9: Electrocution and Electrical Burn Hazards—Electric box doors—Operating the machine with any electric box door unlocked can expose high voltage conductors inside the box.

- Do not unlock or open electric box doors.



WARNING 10: Entangle and Crush Hazards—Guards, covers, and panels—Operating the machine with any guard, cover, or panel removed exposes moving components.

- Do not remove guards, covers, or panels.

4.1.2. Hazards Resulting from Damaged Mechanical Devices



WARNING 11: Multiple Hazards—Operating a damaged machine can kill or injure personnel, further damage or destroy the machine, damage property, and/or void the warranty.

- Do not operate a damaged or malfunctioning machine. Request authorized service.



WARNING 12: Explosion Hazards—Cylinder—A damaged cylinder can rip apart during extraction, puncturing the shell and discharging metal fragments at high speed.

- Do not operate the machine with any evidence of damage or malfunction.



WARNING 13: Explosion Hazards—Clutch and speed switch (multiple motor machines)—A damaged clutch or speed switch can permit the low speed motor to engage during extract. This will over-speed the motor and pulleys and can cause them to rip apart, discharging metal fragments at high speed.

- Stop the machine immediately if any of these conditions occur: • abnormal whining sound during extract • skidding sound as extract ends • clutches remain engaged or re-engage during extract

4.2. Careless Use Hazards

4.2.1. Careless Operation Hazards—Vital Information for Operator Personnel (see also operator hazards throughout manual)



WARNING 14: Multiple Hazards—Careless operator actions can kill or injure personnel, damage or destroy the machine, damage property, and/or void the warranty.

- Do not tamper with or disable any safety device or operate the machine with a malfunctioning safety device. Request authorized service.
- Do not operate a damaged or malfunctioning machine. Request authorized service.
- Do not attempt unauthorized servicing, repairs, or modification.
- Do not use the machine in any manner contrary to the factory instructions.
- Use the machine only for its customary and intended purpose.
- Understand the consequences of operating manually.

4.2.2. Careless Servicing Hazards—Vital Information for Service Personnel (see also service hazards throughout manuals)



WARNING 15: Electrocutation and Electrical Burn Hazards—Contact with electric power can kill or seriously injure you. Electric power is present inside the cabinetry unless the main machine power disconnect is off.

- Do not service the machine unless qualified and authorized. You must clearly understand the hazards and how to avoid them.
- Abide by the current OSHA lockout/tagout standard when lockout/tagout is called for in the service instructions. Outside the USA, abide by the OSHA standard in the absence of any other overriding standard.



WARNING 16: Entangle and Crush Hazards—Contact with moving components normally isolated by guards, covers, and panels, can entangle and crush your limbs. These components move automatically.

- Do not service the machine unless qualified and authorized. You must clearly understand the hazards and how to avoid them.
- Abide by the current OSHA lockout/tagout standard when lockout/tagout is called for in the service instructions. Outside the USA, abide by the OSHA standard in the absence of any other overriding standard.



WARNING 17: Confined Space Hazards—Confinement in the cylinder can kill or injure you. Hazards include but are not limited to panic, burns, poisoning, suffocation, heat prostration, biological contamination, electrocution, and crushing.

- Do not enter the cylinder until it has been thoroughly purged, flushed, drained, cooled, and immobilized.

— End of BIUUUS27 —

Guards & Covers
3010 & 3015 G5E, G5X, CGE

BMP040011/2004055V
(Sheet 1 of 2)



Pellerin Milnor Corporation
P. O. Box 400, Kenner, LA 70063-0400

Litho in U.S.A.

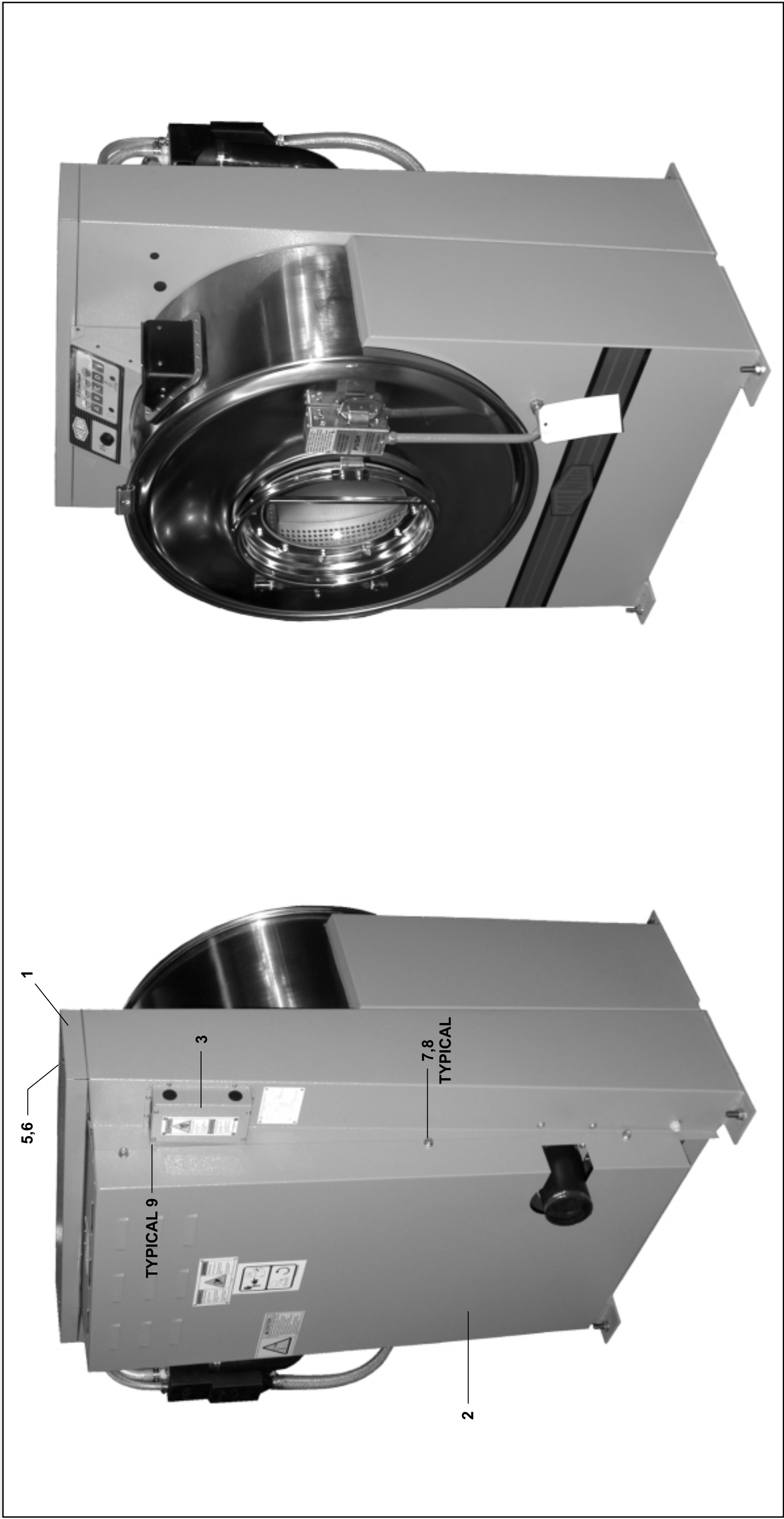

Guards & Covers

3010 & 3015 G5E,G5X,CGE



Pellerin Milnor Corporation
P. O. Box 400, Kenner, LA 70063-0400

BMP040011/2004055V
(Sheet 2 of 2)

Litho in U.S.A.

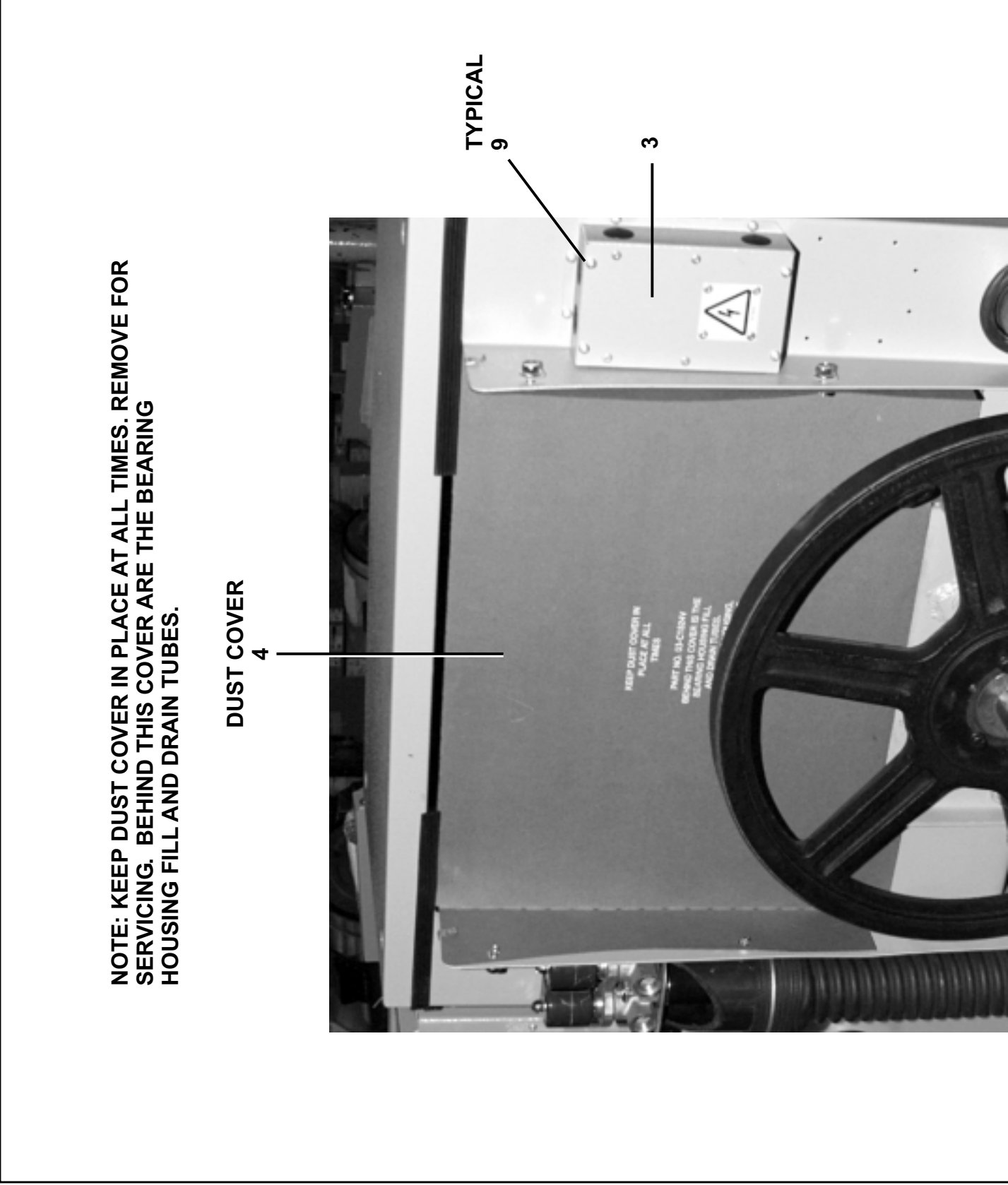

Parts List- Guards & Covers

Find the correct assembly first, then find the needed components. The item letters (A, B, C, etc.) assigned to assemblies are referred to in the "Used In" column to identify which components belong to an assembly. The item numbers (1, 2, 3, etc.) assigned to components relate the parts list to the illustration.

Used In	Item	Part Number	Description	Comments
	A	GGC30002	3010 GUARDS/COVERS INSTALL	
			-----ASSEMBLIES-----	
			-----COMPONENTS-----	
all	1	02 03699E	3010 REAR TOP COVER	
all	2	02 03497B	GUARD REAR BELT FULL	
all	3	03 C4X7	COVER:SYSTEM 7 LIQUID SUPPLY	
all	4	03 C1824V	DUST COVER-30"V6J BELT	
all	5	15K120	HXCAPSCR 3/8-16UNC2AX2 GR5 ZIN	
all	6	17N070P	RETAIN NUT 3/8-16 #S10100-27	
all	7	15P200	TRDCUT-F HXWASHD 3/8-16X3/4NIK	
all	8	15U346	FLAWASH 7/8X3/8X.030 NATURAL N	
all	9	15P185	TRDCUT-F HXHD 1/4-20UNC2AX3/4	

About the Forces Transmitted by Milnor® Washer-extractors

Document BIWUUI02
Specified Date 20001108
As-of Date 20001108
Access Date 20001108
Applicability.....WUU

During washing and extracting, all washer-extractors transmit both static and dynamic (cyclic) forces to the floor, foundation, or any other supporting structure. During washing, the impact of the goods as they drop imparts forces which are quite difficult to quantify. Size for size, both rigid and flexibly-mounted machines transmit approximately the same forces during washing. During extracting, rigid machines transmit forces up to 30 times greater than equivalent flexibly-mounted models. The actual magnitude of these forces vary according to several factors:

- machine size,
- final extraction speed,
- amount, condition, and type of goods being processed,
- the liquor level and chemical conditions in the bath preceding extraction, and
- other miscellaneous factors.

Estimates of the maximum force normally encountered are available for each Milnor® model and size upon request. Floor or foundation sizes shown on any Milnor® document are only for on-grade situations based only on previous experience without implying any warranty, obligation, or responsibility on our part.

1. Rigid Machines

Size for size, rigid washer-extractors naturally require a stronger, more rigid floor, foundation, or other supporting structure than flexibly-mounted models. If the supporting soil under the slab is itself strong and rigid enough and has not subsided to leave the floor slab suspended without support, on grade installations can often be made directly to an existing floor slab if it has enough strength and rigidity to safely withstand our published forces without transmitting undue vibration. If the subsoil has subsided, or if the floor slab itself has insufficient strength and rigidity, a deeper foundation, poured as to become monolithic with the floor slab, may be required. Support pilings may even be required if the subsoil itself is “springy” (i.e., if its resonant frequency is near the operating speed of the machine). Above-grade installations of rigid machines also require a sufficiently strong and rigid floor or other supporting structure as described below.

2. Flexibly-mounted Machines

Size for size, flexibly-mounted machines generally do not require as strong a floor, foundation, or other supporting structure as do rigid machines. However, a floor or other supporting structure having sufficient strength and rigidity, as described in section 3, is nonetheless vitally important for these models as well.

3. How Strong and Rigid?

Many building codes in the U.S.A. specify that laundry floors must have a minimum live load capacity of 150 pounds per square foot (732 kilograms per square meter). However, even compliance with this or any other standard does not necessarily guarantee sufficient rigidity. In any event, it is the sole responsibility of the owner/user to assure that the floor and/or any other supporting structure exceeds not only all applicable building codes, but also that the floor and/or any other supporting structure for each washer-extractor or group of washer-extractors actually

has sufficient strength and rigidity, plus a reasonable factor of safety for both, to support the weight of all the fully loaded machine(s) including the weight of the water and goods, and including the published 360° rotating sinusoidal RMS forces that are transmitted by the machine(s). Moreover, the floor, foundation, or other supporting structure must have sufficient rigidity (i.e., a natural or resonant frequency many times greater than the machine speed with a reasonable factor of safety); otherwise, the mentioned 360° rotating sinusoidal RMS forces can be multiplied and magnified many times. It is especially important to consider all potential vibration problems that might occur due to all possible combinations of forcing frequencies (rotating speeds) of the machine(s) compared to the natural frequencies of the floor and/or any other supporting structure(s). A qualified soil and/or structural engineer must be engaged for this purpose.

Figure 1: How Rotating Forces Act on the Foundation

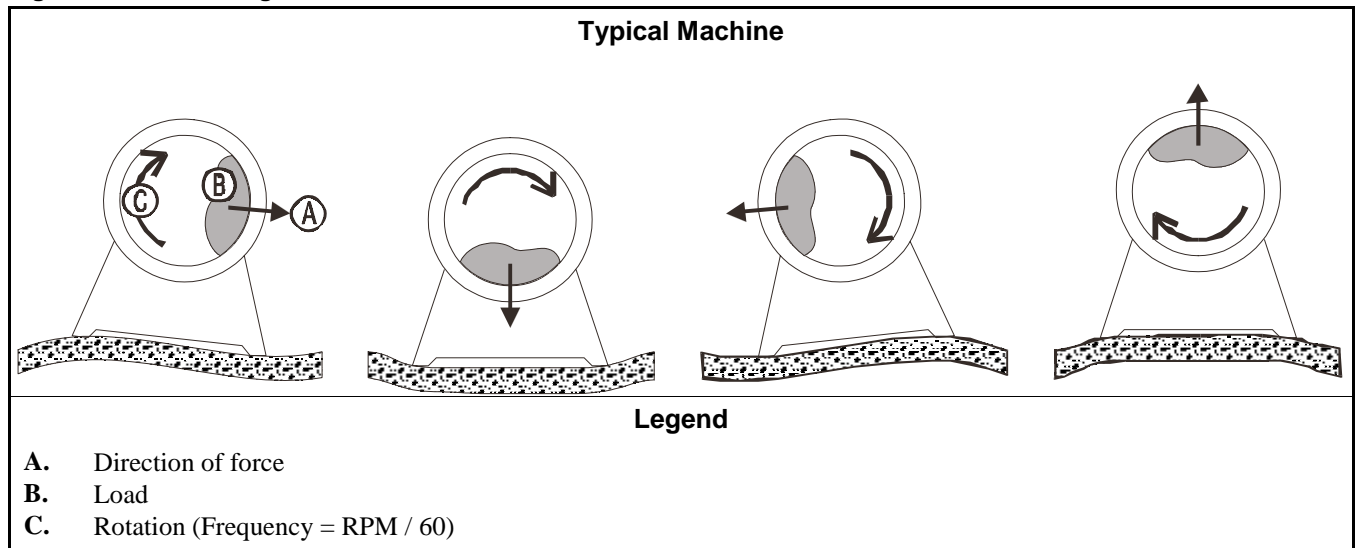
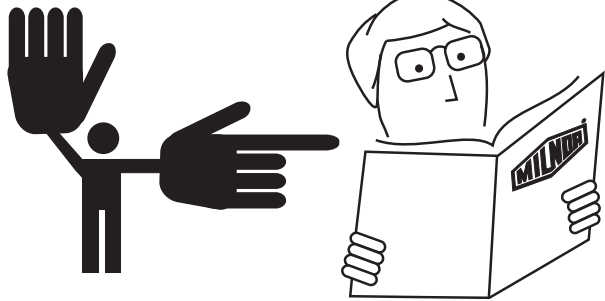
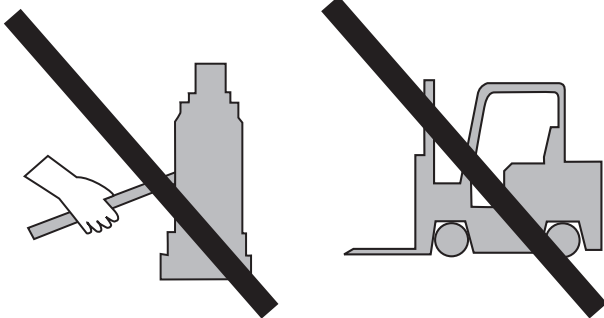
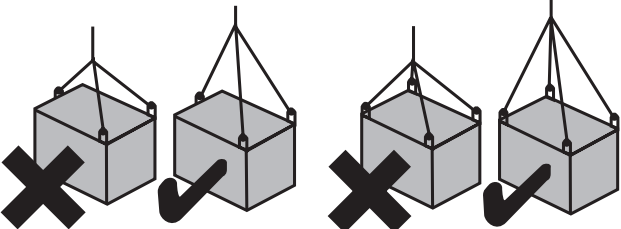
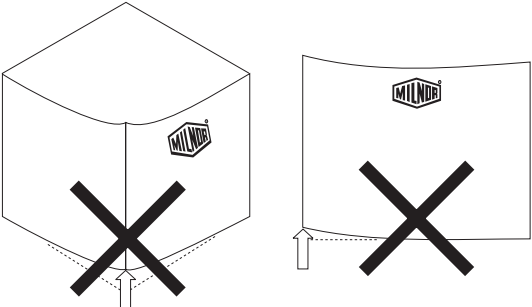

Figure 1 above is intended to depict both on-grade and above-grade installations and is equally applicable to flexibly-mounted washer-extractors, as well as to rigid models installed either directly on a floor slab or on a foundation poured integrally with the slab. Current machine data is available from Milnor® upon request. All data is subject to change without notice and may have changed since last printed. It is the sole responsibility of every potential owner to obtain written confirmation that any data furnished by Milnor® applies for the model(s) and serial number(s) of the specific machines.

Glossary of Tag Illustrations— G-Style, 30" T-Style, & 30" V-Style Washer-Extractors

MSIUUMTGAE/2004072V

Illustration	Explanation
	Stop! Read the manual first for complete instructions before continuing.
	Do not jack the machine here. Do not lift the machine here.
	Use three point or four point lifting as determined by the lifting eyes furnished. Rig the load using lifting cables of sufficient size and length to ensure cables are not over-stressed.
	Do not lift the machine from one corner or one side edge.

Illustration

Explanation

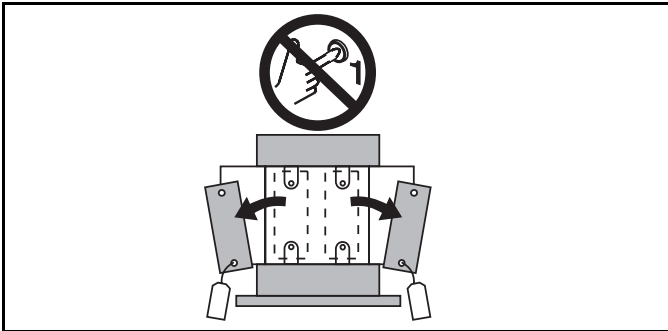

Do not start this machine until the packing materials, lifting brackets, etc. with this tag attached or behind this panel are removed. These materials are painted red. Safety stands or brackets (also painted red) may be provided with this machine. Do not discard safety stands or brackets



This motor or pump should rotate in the direction of the arrow.

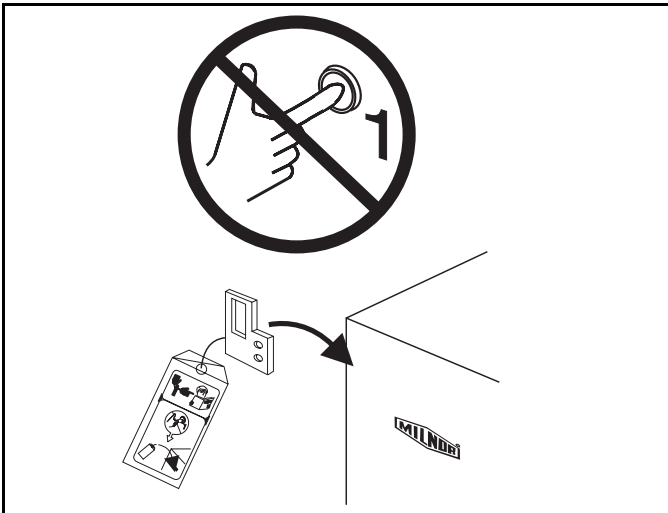

Do not start this machine until the part with this tag is installed on the machine.

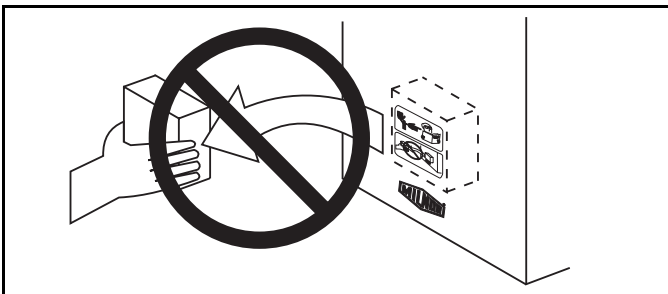

Do not remove this component from the machine.

Illustration

Explanation

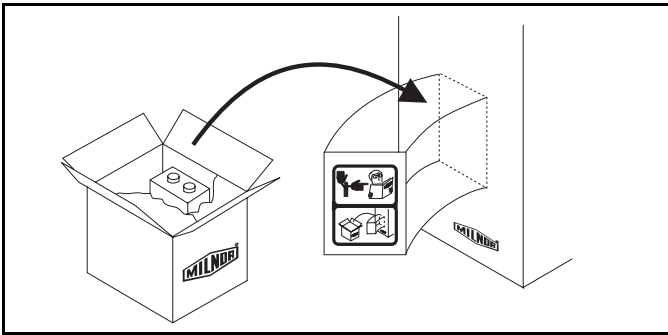

Install the appropriate part here before operating the machine.

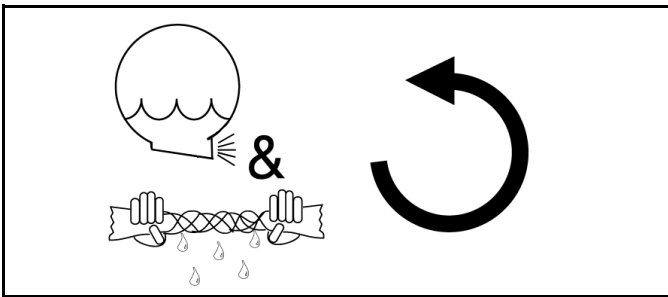

During drain and extract, the cylinder must rotate counterclockwise when viewed from here (rear of machine).

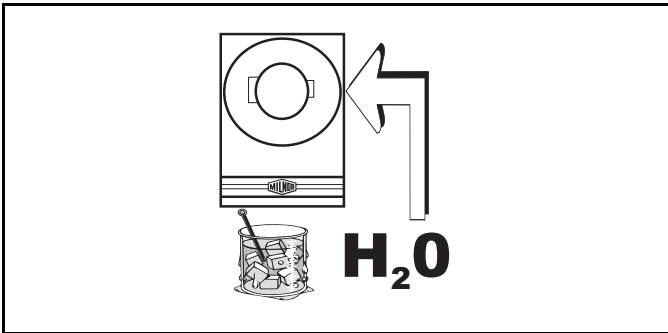

Make cold water connection here.

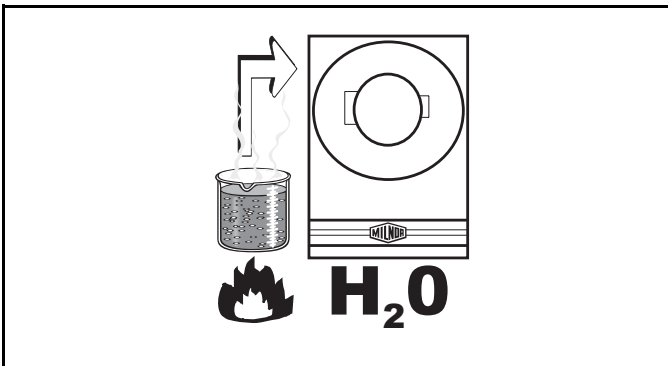

Make hot water connection here.

Illustration

Explanation

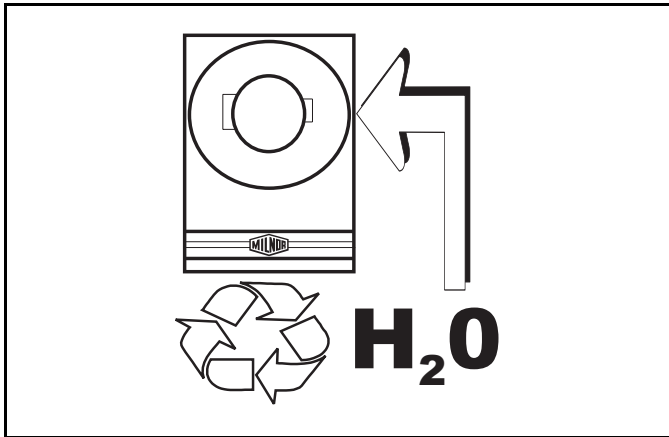

Make third (reuse) water connection here.

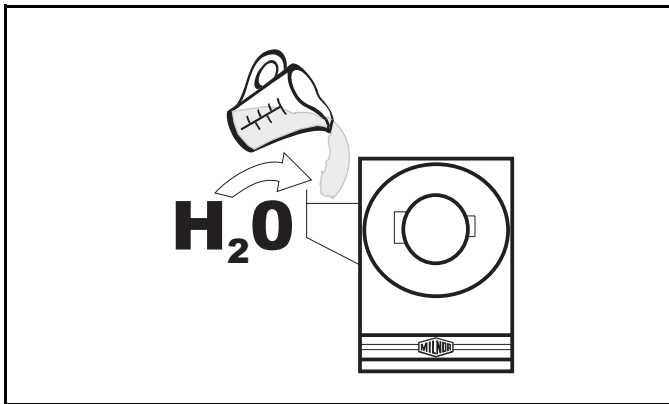

Make flushing water connection here.

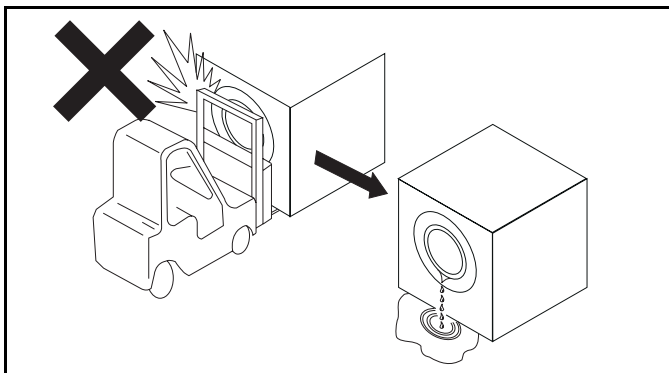

Do not strike shell front of washer-extractors during fork lifting. Striking shell front will cause door to leak.



Water hammer will rupture the water inlet valves on this machine. Eliminate water hammer on waterlines to this machine. Follow all applicable codes when installing water hammer arresters on water lines.

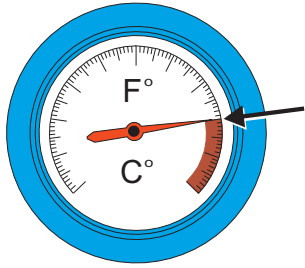

$\leq 160 \text{ F}^\circ$

$\leq 71 \text{ C}^\circ$

Excessive water temperature will damage valves. Do not exceed 160 degrees Fahrenheit (71 degrees Celsius).

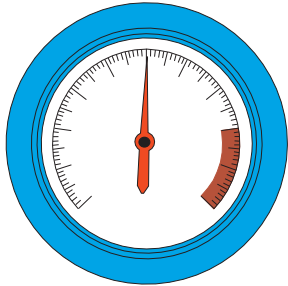

10 - 75 psi

0.7 - 5.1 bar

Excessive air pressure will damage valves. Do not exceed 80 psi (5.5 bar).

Avoiding Damage From Allied Remote Chemical Delivery Systems

Milnor® does not manufacture or supply remote chemical delivery systems and this document is meant only to illustrate some of the possible problems that can be minimized during installation of such systems by the chemical supply company. Milnor washer-extractors and CBW® batch washers (tunnels) are available with convenient inlets for such systems (see Figure 1). Most common of the types of systems currently used in commercial laundering operations are pumped chemical systems. Other types, such as constant pressure, re-circulating ring main systems have also been, and may continue to be used with Milnor equipment.

This document warns about some of the possible hazards posed by chemical systems and lists certain requirements needed to minimize those hazards. The procedures for interfacing with allied chemical systems and information pertinent to chemical use in general are provided elsewhere in the product manuals (see Note 1).

Figure 1: Pumped Chemical Inlets on CBW Batch Washer



Note 1: Misuse of laundering chemicals (such as injecting excessive concentrations of chlorine bleach or permitting acid sours to react with hypo chlorite) due to incorrect formulation can also be hazardous. Information pertinent to chemical use is provided elsewhere in the product manuals.

1. How a Chemical System Can Damage the Machine It Serves

Milnor has manufactured washer-extractors and tunnel washers with the same stainless steel specification since its founding. Every batch of steel used is certified and documented by the steel mill. Testing of samples damaged by corrosion have, in every case, proven the steel to be well within the AISI 304 specification.

Chemical products commonly found in the laundry industry, when used in **established** dosages and proper operating parameters, under the auspices of an experienced chemical specialist, should produce satisfactory results, with no consequential detrimental effects. The industry has published standards in Riggs and Sherrill, “Textile Laundering Technology”. However, the stainless steel can be damaged and even destroyed by **abnormal** contact with chlorine bleach, hydrofluosilicic acid and other commonly used chemicals, as will occur if chemicals are unintentionally leaked into the machine, particularly when it is no longer in use and especially when machine surfaces are dry.

Some chemical systems have been found to permit chemicals to dribble from the supply lines, or worse, to siphon from the supply tank into the machine, during operation and long after the system is shut down—as after working hours and during weekends. If this occurs, **deterioration (rusting) of the stainless steel and damage to any textiles therein will inevitably result. If this condition goes undetected, machine damage is likely to be catastrophic.** No machine is immune to such damage.



CAUTION 1: **Equipment and Textile Damage Hazards**—Chemicals leaked into the machine, particularly when it is idle can destroy machine components and textiles left in the machine. **Pellerin Milnor Corporation accepts absolutely no responsibility for damage to its equipment or to textiles therein from abnormal contact with chemicals.**

- Ensure that the chemical system prevents unintentional release of chemicals.
- Inspect regularly for proper operation and evidence of damage.

2. Requirements for Chemical Systems Used With Milnor Machines

It is the responsibility of the chemical system manufacturer and supplier to ensure that their system is safe for personnel and equipment. Some important points are described below.

- 2.1. **Ensure the System Cannot Siphon.**—The supply system must be designed to counteract any siphoning that could occur as a result of having a sealed supply line between the bottom of the chemical tank and the internal machine connection at the drain trough. As shown in the Figure 2 examples, if the pump (P) and/or the valving does not provide positive closure and there is no vacuum breaker protection, siphoning is likely to occur. In each of the Figure 2 illustrations, the volume of chemical in the tank above the siphon level (S), and indicated by shading, will flow into the machine.

Figure 2: Siphoning From the Chemical Tank into the Machine

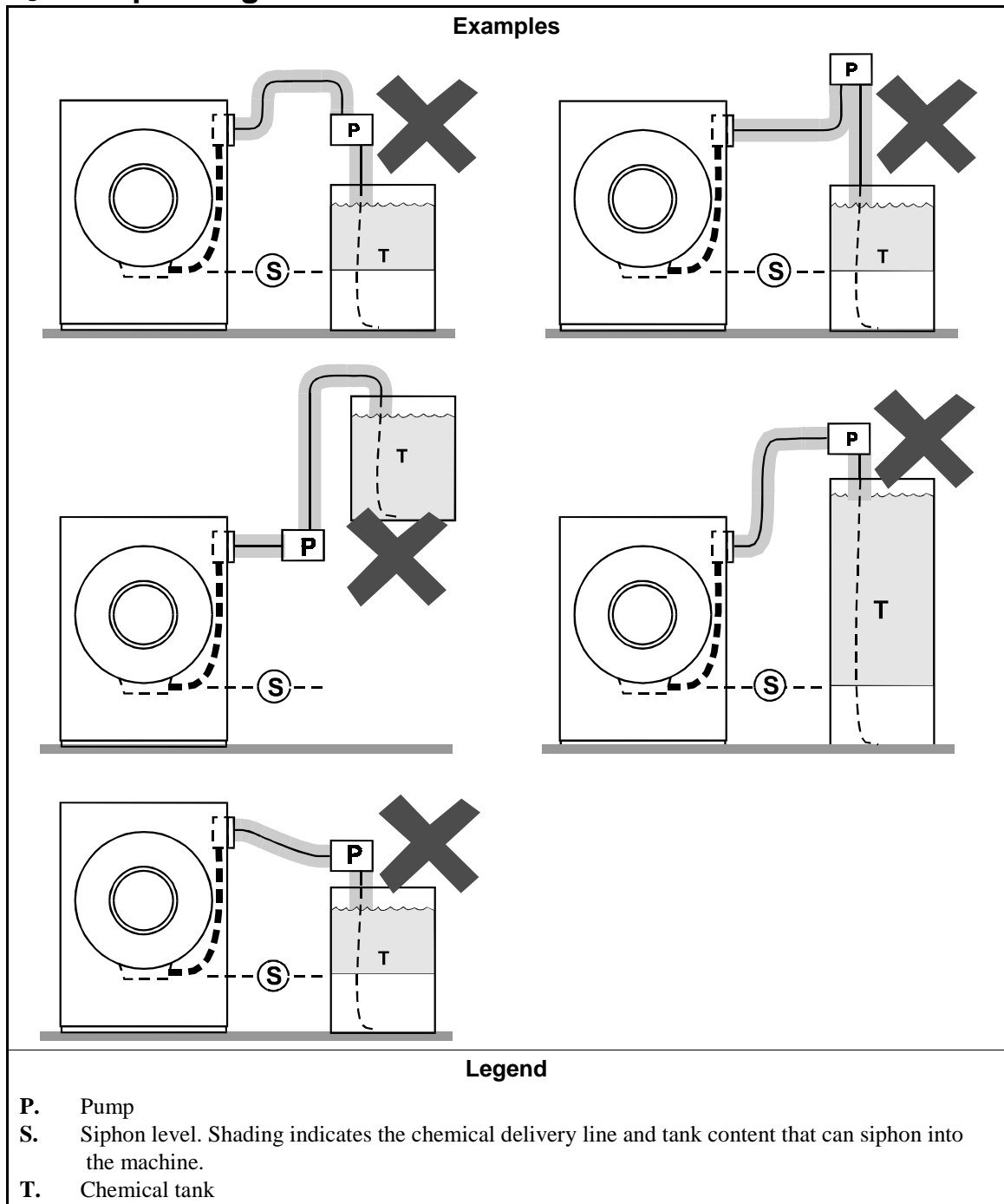

2.2. **Ensure the Chemical Lines Cannot Dribble**—The pumped chemical system may provide a means of positively closing the chemical line at the pump location, but not at the injection site. Hence, any concentrated chemical that remains in the injection line between the pump and the machine is free to flow into the machine. Some examples of this are shown in Figure 3.

Figure 3: Dribbling From Chemical Supply Line Into Machine (assumes positive closure at the pump)

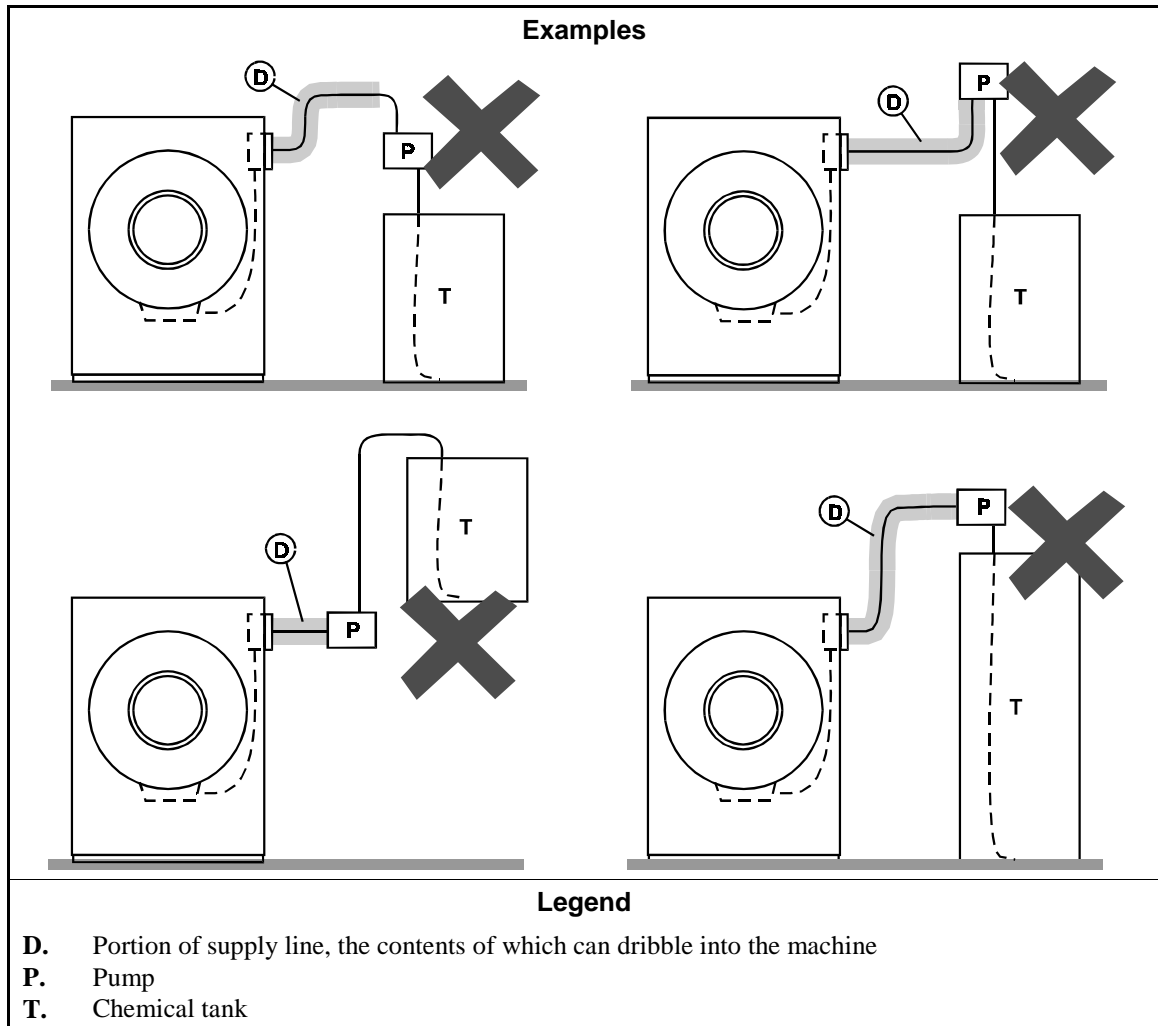

3. Design and Installation Recommendations

It is the responsibility of the chemical system manufacturer and supplier to use whatever measures are necessary to ensure that their system is safe for personnel and equipment. The following are some of the possible methods the manufacturer or supplier may wish to use, as appropriate.

- 3.1. **Siphoning: Positively close the line.**—If the pump does not provide positive closure when the system is off, employ a shutoff valve in the line to serve this purpose.
- 3.2. **Siphoning: Break the siphon.**—Provide an air gap or vacuum breaker in the chemical delivery line. This must be located above the “full” line of the tank.
- 3.3. **Dribbling: Flush the entire chemical delivery line.**—If any concentrated chemical that remains in the injection line between the pump and the machine is free to flow into the machine, employ a system that flushes the entire line between the pump and the injection point with fresh water after each injection.

- 3.4. **Dribbling: Locate the entire chemical line below the machine inlet.**— Assuming the chemical system does not retain any line pressure and that the pump provides positive closure when the system is off, locate the entire chemical delivery line below the level of the chemical inlet. An example of this is shown in Figure 4.

Figure 4: Locating a Pumped Chemical System With Positive Closure To Protect Against Machine Damage

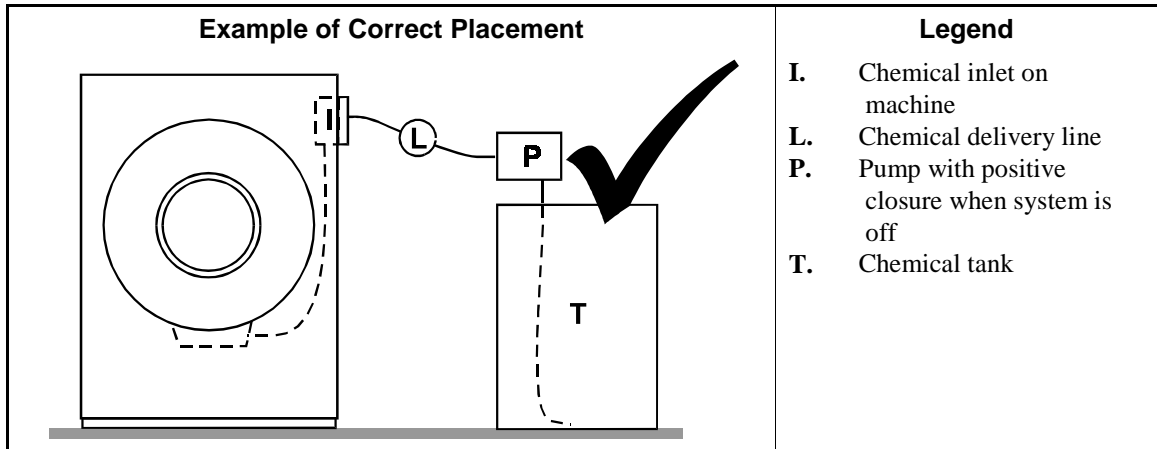

4. Guarding Against Leaks

All personnel who may work with the chemical system (e.g., chemical system manufacturer, chemical system supplier, chemical supplier, operator, maintenance personnel) should be vigilant in observing for leaks in the system. When connecting, or reconnecting chemical lines, whether at installation, after taking samples, or when replacing components, at a minimum ensure that:

1. the proper components are used,
2. all connections are the proper fit, and
3. all components are securely connected.



CAUTION [2]: Injury and Damage Hazards—Chemicals leaking from a chemical system may be corrosive or toxic. Such chemicals can injure personnel and damage equipment.

- Use care when connecting chemical lines.
- Inspect regularly for leaks.

— End of BIWUI03 —

Handling and Setting Procedures for Rigid Mount Washer-Extractors

1. Handling Precautions

1. Remove the protective coverings (leaving the machine on shipping skids) and carefully examine for possible shipping damage. **If the machine is damaged, notify the transportation company immediately.**

Note 1: Once the machine is given to the carrier for delivery, it is the sole responsibility of the carrier to ensure that no damage occurs during transit. In addition to readily apparent damage, carriers are liable for concealed damage. **Do not hesitate to file a claim with the carrier if the machine is damaged in any way during shipment.** Milnor® will be glad to assist you in filing your claim, but is not responsible for any shipping damage to the machine once it has been delivered to the carrier in good condition.

2. Consult Milnor® for instructions if crane lifting is required.
3. Use skids with the forklift. If possible, leave the machine on the shipping skids until it is about to be placed in its final position. Once the skids are removed, take care in placing forks under the machine. **Do not allow the forks to come in contact with valves, piping, motors, etc., located under the machine.**
4. Never push, pull, or exert pressure on any components that protrude from the machine frame (shell front, door, supply injector, electric boxes, controls, belt guard, conduits, inlet piping, etc.).
5. Ensure that the shell door is closed and secured.

2. Site Requirements

2.1. Space Requirements

1. All openings and corridors through which equipment must pass during installation must be large enough to accommodate the width and the height of the machine (as shown on the dimensional drawings). It is occasionally possible to reduce the overall dimensions by removing piping or other special modifications. Consult Milnor® for additional information.
2. Sufficient clearance must be provided for normal operation and maintenance procedures.

2.2. Operational Requirements

1. Allow sufficient ventilation for heat and vapors of normal operation to dissipate.
2. Provide easy access to controls. Operators must be able to reach and view all status lights, machine controls, and any additional controls associated with the machine (e.g., electrical power connections, water and steam shut-offs, etc.).

- 2.3. **Foundation Requirements**—The machine must be anchored in accordance with the installation instructions. The floor and/or all other support components must have sufficient strength (and rigidity with due consideration for the natural or resonant frequency thereof) to withstand the fully loaded weight of the machine, including the wet goods and any repeated sinusoidal (rotating) forces generated during its operation. Determining the suitability of floors, foundations, and other supporting structures normally requires analysis by a qualified structural engineer. See “ABOUT THE FORCES TRANSMITTED BY MILNOR® WASHER-EXTRACTORS” (See Table of Contents) for more information.

3. Anchoring Requirements

Machines must be securely anchored to an adequate foundation. Anchor bolt locations and foundation specifications are provided on the dimensional drawing (see Table of Contents). **However, never install anchor bolts firmly in the foundation using only the dimensional drawing or a template.** Approximate anchor bolt locations may be determined from a foundation template (standard equipment on some machines, optional on others). Recommended anchor bolt installation (see dimensional drawing) calls for each anchor bolt to be set in a pipe sleeve. The foundation template or dimensional drawing will only locate foundation bolts accurately enough so that the play of the bolt within the pipe sleeve permits the machine to fit anchor bolts. **If another bolt installation procedure is used, do not install the bolts until the machine is on site and bolt locations can be determined.** Consult Milnor if any obstruction prevents the installation of any anchor bolt. **Properly install anchor bolts at ALL anchor bolt holes on the machine. Anchor bolts cannot be indiscriminately omitted.**



CAUTION 1: STRIKE AND MACHINE DAMAGE HAZARDS—A machine can “rip” away from position on foundation if the machine is not anchored and grouted in strict accordance with the dimensional drawing and setting instructions provided in this manual. Damage resulting from improper installation is not covered by warranty.

- Strictly follow setting instructions and dimensional drawing guidelines when anchoring and setting this machine.

4. Setting Procedures

See Figure 1 during the following procedures:

1. With the machine near the final location, unbolt the shipping skids. Observing all precautions, lift the machine off its skids and lower the machine onto temporary blocking as shown in Figure 1. Install anchor bolts, taking care to align the bolts with the base plates to avoid bolt thread damage.
2. **Determine that the minimum clearance between each base plate and floor surface is as specified (see dimensional drawings).** Shim the machine at temporary blockings to level the machine from left to right and front to back. Use a carpenter's level along the right and left side of the base to determine if the machine is level from front to back. Place a level laterally across the base plates to determine if the machine is level from right to left.

Note 2: Do not pull on conduit when moving the machine. Tampering with the conduit may require adjustment of the door switch

Figure 1: Temporary Blocking Points

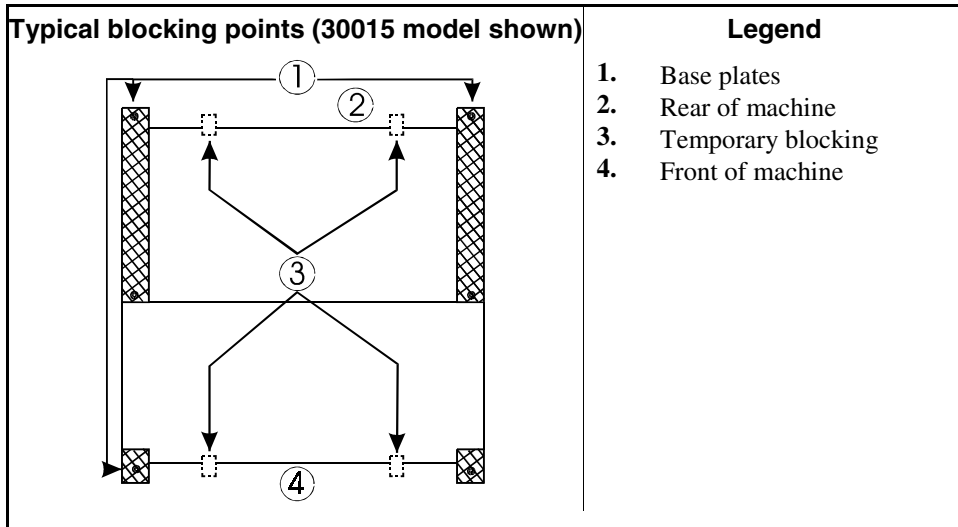

CAUTION [2]: MACHINE DAMAGE AND MALFUNCTION HAZARDS—Tightening anchor bolt fasteners onto spacers (without grout or with improperly applied grout) twists the machine frame and causes cylinder misalignment.

- Never tighten anchor bolt fasteners before grouting.
 - Grout must displace total clearance between base plate and existing foundation floor. Voids must not exist!
3. After determining the final position of the machine, apply grout between the existing foundation floor and base plates, while observing the following considerations:
 - All machines are designed to be grouted under the full area of all base plates. Grout prevents the anchor bolts from distorting the frame when the fasteners are tightened. Total area under each base plate must be completely filled with grout (see dimensional drawings). Voids under base plates can magnify vibration, causing unsatisfactory operation. Use only industrial strength non-shrinking grout.
 - If the grout (after mixing) is of proper consistency, pack or trowel it by hand.
 - If the grout (after mixing) is too thin (causing it to flow from under the base pads), install temporary cardboard framing around the pads to retain the grout until it cures.
 4. After the grout has completely cured, raise the machine sufficiently to remove all temporary blocking and shims. **Be careful to avoid disturbing or damaging grout.**
 5. Tighten all foundation fasteners until they contact the top of the base plate. Center bolt holes are located inside rear console. Install center hold down bolts properly to ensure successful operation.
 6. Tighten all fasteners evenly, using only one-quarter turn on each fastener before moving to the next one. While tightening, frequently skip from front to back and right to left to insure uniform tension. After tightening all fasteners, check each fastener at least twice.

— End of BIRUI01 —

Service Connections

1. General

Required service connections, (depending on machine model and optional features) are as follows:

1. Piped inlets and outlets (cold water, hot water, flush water, third water, direct steam, compressed air, liquid supply, and drain to sewer). The sizes and locations of piped inlets and outlets are shown on the dimensional drawing for your machine.
2. Electrical power connections.

2. Requirements for Piped Connections

Notice 1: Machine Damage—Plastic water valves can fail if improper connectors are used.

- Only use garden hose bib type connectors.
1. Inlet pressures must be within the minimum/maximum range specified. Pressure outside of the specified range may cause the machine to operate inefficiently or malfunction and may damage machine components.
 2. Thoroughly flush all water lines before making connections.
 3. We recommend installing 40 mesh strainers or filters in front of the cold, hot and third water valves.
 4. When connecting water and steam inlets, always install unions and shut off valves at the point of connection to permit removal of the machine components for servicing, when necessary.
 5. Suds overflow (if so equipped) to drain, must be vented per plumbing code.



CAUTION 2: Machine Damage Hazards—Pumped chemical systems, if not properly installed, can cause corrosion damage.

- See the reference manual for precautions and additional information before making any chemical connections.

3. Piped Inlet Specifications

Table 1: Piped Inlets

Connection Description	Source Requirements	Piping Requirements, Comments
Cold water inlet	3/4" garden hose male thread @ 10 - 75 psi	Pipe material per plumbing code
Hot water inlet(s)		
Third/Flush water (if equipped)		
Liquid supply inlet	3/8" or 1/2"	Flexible tubing as supplied by the chemical supplier

4. Piped Outlet Specifications

Piped outlet requirements are as follows (see dimensional drawing for connection sizes and locations):

Table 2: Outlets

Connection Description	Destination Requirements or Description	Piping Specifications
Drain	3" pipe socket joint, unrestricted gravity feed to sewer (external back pressure may extend wash times - Do not reduce)	Rubber hose, PVC or other approved material per plumbing code
Suds Overflow (if so equipped)	2" flexible pipe adapter connection	Per code

5. Power Connections and Precautions



WARNING 3: Electrocutation and Electrical Burn Hazards—Contact with high voltage will electrocute or burn you. Power switches on the machine and the control box do not eliminate these hazards. High voltage is present at the machine unless the main machine power disconnect is off.

- Do not service machine unless qualified and authorized.

Notice 4: Machine Damage—Voltage fluctuations of more than 10% above or below the specified voltage for your machine can damage electrical components, especially motors.

- Any such conditions should be corrected prior to commissioning your machine.

The customer must furnish a remotely mounted disconnect switch with lag type fuses or circuit breakers, and wiring between the electrical service box and the junction box on the machine. The sizes of these fuses and wires, along with the motor fuses supplied with the machine, depend on the machine voltage. See the fuse and wire sizing information in the External Fuse and Wire Size manual and on the machine nameplate. See dimensional drawings in this manual for electrical connection locations.

1. Electrical connections must be made by a competent electrician.
2. See fuse and wire sizing information in the External Fuse and Wire Size manual and on the machine nameplate. If the wire runs more than 50 feet, increase by one wire size for each additional 50 feet.
3. Only use Bussman Fusatron FRN (up to 250V), FRS (up to 600V) or similar lag fuses, the nameplate fuse sizes must not be applied to standard fuses.
4. Stinger leg, if any, must be connected to terminal L3, never to terminals L1 or L2.
5. Make power and liquid supply electrical connections within junction boxes on the rear of the machine.
6. Verify motor rotation (Figure 1). See the operating and trouble shooting manual for more information. If the cylinder turns in the wrong direction, interchange the wires connected to L1 and L2. Never move L3 under any circumstances. All motors are phased for proper rotation. Never attempt to reconnect motors or the motor control devices.
7. Machine is shipped set for 240 volt operation from the factory (Figure 2). If the supply voltage is 208 volts, then remove the top, and place the line voltage switch in the 208 volt position.

Figure 1: Correct Rotation During Drain and Extract (when viewing front of machine)

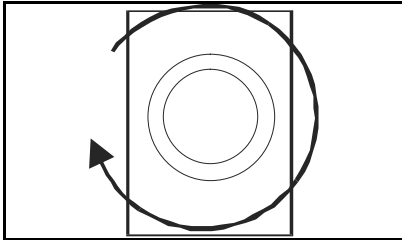
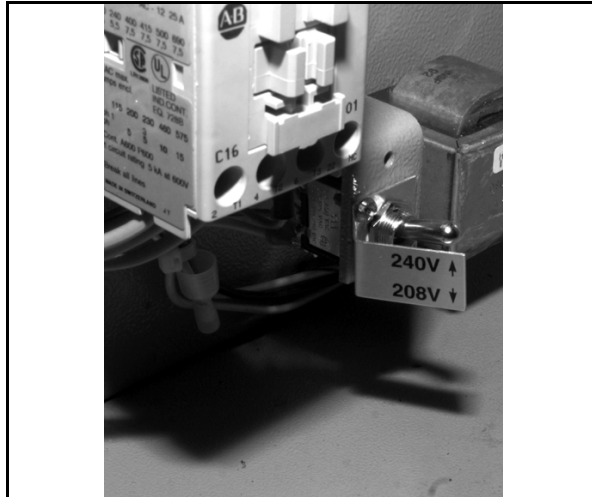

Figure 2: Line Voltage Switch Set for 240 Volt Operation



6. Remove Shipping Restraints

Remove all shipping restraints (usually marked in red). Restraints may be located behind access panels. Restraints may include the vibration switch restraint.

Figure 3: Typical Vibration Switch showing restraint in place

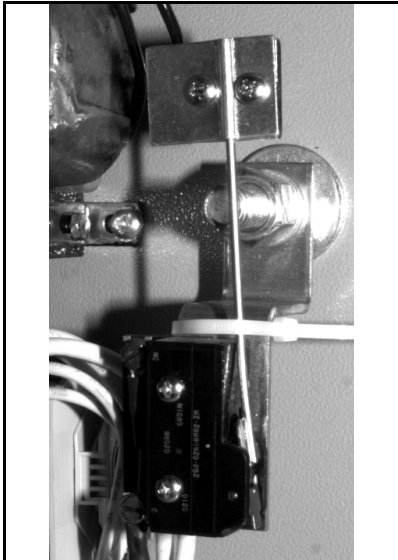

7. Check Cylinder Surface

Check the perforated cylinder for smoothness. Milnor will not accept responsibility for the cylinder finish after the machine is placed in service.

— End of BIRQVI01 —

Section
Service and Maintenance

1

Preventive Maintenance

1. Lubrication Guidelines

As required by the warranty, to ensure safe operation, and to achieve optimum performance and service life from Milnor® washer-extractors, the schedules, instructions, and precautions herein must be strictly followed.



WARNING 1: Entangle and Crush Hazard—Belts and pulleys can entangle and crush body parts.

- Lock OFF and tag out power at the wall disconnect before servicing, except where specifically instructed otherwise in this section.
- Insure belt and pulley guards are in place during service procedures.
- Permit only qualified maintenance personnel to perform these procedures.

2. 36021C4E Main Bearing Maintenance

36021C4E main bearing housings are oil-filled and require periodic draining and refilling (see below).

See the appropriate “MAIN BEARING ASSEMBLY” (see Table of Contents) during this procedure.

1. Remove the drain plug on the bottom of the main bearing housing and allow the bearing housing to drain completely (Figure 1). Inspect the leak-off, drained oil, and magnetic drain plug for water and/or metal particles. Install the drain plug. Water and/or metal particles can indicate worn or damaged seals and bearings.
2. Locate the two 1/2" plastic tubes secured to the electrical control chassis (Figure 2). Clean the surrounding area and remove the cork stoppers from each.
3. Strictly following lubrication specifications, refill the bearing housing. After refilling the bearing housing, re-install the cork stoppers and clean any excess lubricant from the machine.

3. Preventive Maintenance Schedule

Table 1: Preventive Maintenance Checklist

Component		Action	Frequency	Specifications/Figure
Bearing Housing	Oil	Remove fill, vent and drain stoppers. Refill 22 ounces (634 grams)	Every four months	High quality SAE 30 to 50 (ISO 100 - 220) single weight heavy duty motor oil (non-detergent if available). See "Oil Drain and Water Leak-off" and also see "30022C4x,..Fill/Vent Hoses"
	Drive Train	Belts and pulleys	Check for wear, replace as required	Monthly
	Motors (if equipped with grease fittings) (See Note 2)	See "Baldor Motor Maintenance....," in this manual (See Note 3)	Every three Months	See motor nameplate. If not specified, use Shell Alvania (or equivalent). See "Motor Grease Points"
Drive Inverter	Inverter	Verify fan operation. Vacuum out inverter vents.	Monthly	See "Inverter Maintenance Points"
Hoses, Clamps, and Connections	Inlet, drain, and chemical hoses and connections	Check for leaks, cracks and bulges	Monthly	
Bolts	Foundation	Check bolt tightness and wear	Monthly	See dimensional drawings
	Rear bearing reinforcement plate and throughout machine			See "30022C4x,..Rear Reinforcement Plate" for 36021C4E and 36026V5J machines, or "42026V6J Rear Reinforcement Plate" for 42026V6J machines.

Note 1: Monthly/200 hours = Once a month or once every 200 operating hours, whichever comes first.

Note 2: Do not over-lubricate motors. Over-lubrication of a motor can seriously damage it by forcing grease into motor windings.

Note 3: If motor manufacturer's instructions conflict with manual section MSSM0274AE, follow manufacturers instructions. Motors are warranted by the manufacturers, not by Milnor.

4. Maintenance Points

Figure 1: 30022C4x, 30022T5x, 36021C4E and 36026V5J Oil Drain and Water Leak-off

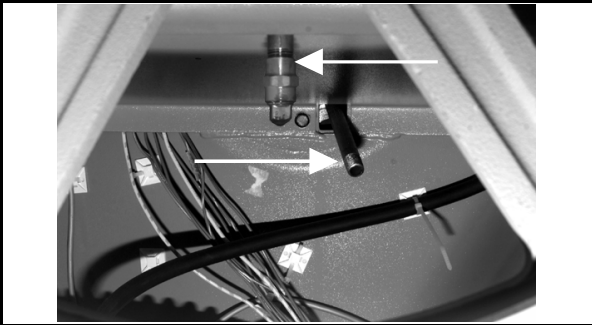

Figure 2: 30022C4x, 30022T5x, 36021C4E and 36026V5J Oil Fill/Vent Hoses (use either hose for filling)

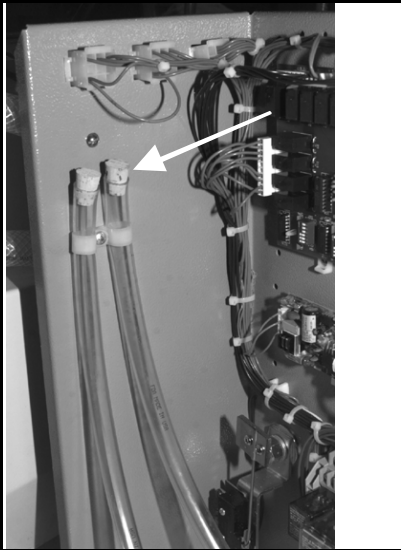

Figure 3: Drive Train Pulleys and Belts (30022V6J shown)

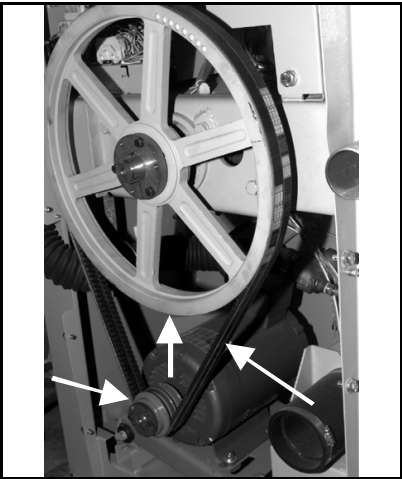

Figure 4: 30022C4x, 30022T5x, 30022V6J, 36021C4E and 36026V5J Rear Bearing Reinforcement Plate (30022VxJ shown)

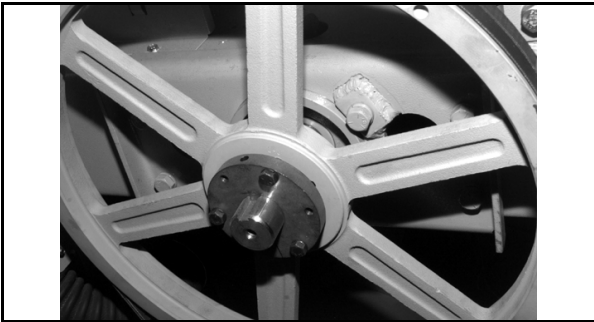
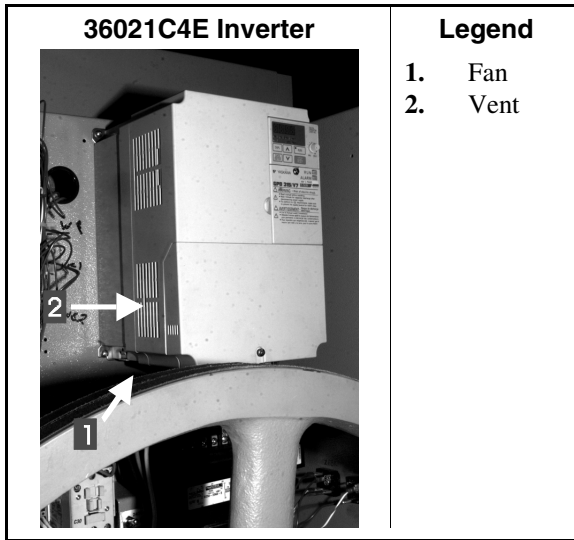

Figure 5: Inverter Maintenance Points



— End of BIRQUM01 —

FASTENER TORQUE REQUIREMENTS

The specifications in this section apply to 1/4 inch and larger Unified National fine and coarse fasteners used on Milnor[®] machines. This information is to be used only when torque specifications are not stated in the installation or service instructions.

When tightening applicable fastener, abide by the following precautions:

1. Always use new fasteners. Replace bolts, nuts, flat washers, and lock washers in the order shown on the parts drawing.
2. Unless otherwise specified, use:
 - Loctite[®] 271 threadlocker or equivalent for bearing housing mounting bolts from one half to one inch in diameter.
 - Loctite[®] 277 threadlocker or equivalent for bearing housing mounting bolts of one inch diameter or larger.
 - Loctite[®] 242 threadlocker for all other fasteners requiring thread locking compound.
3. Use a torque wrench to assure proper tightness.
4. Never lubricate fasteners. The values specified herein are maximum recommended torques and are calculated from published ASTM and SAE data. Actual allowable torques are application dependent and can vary for many reasons, (joint types, gaskets, etc.). Use these values as a guide.
5. Although FIGURE 1 depicts hex head bolts, the table applies to all head types.

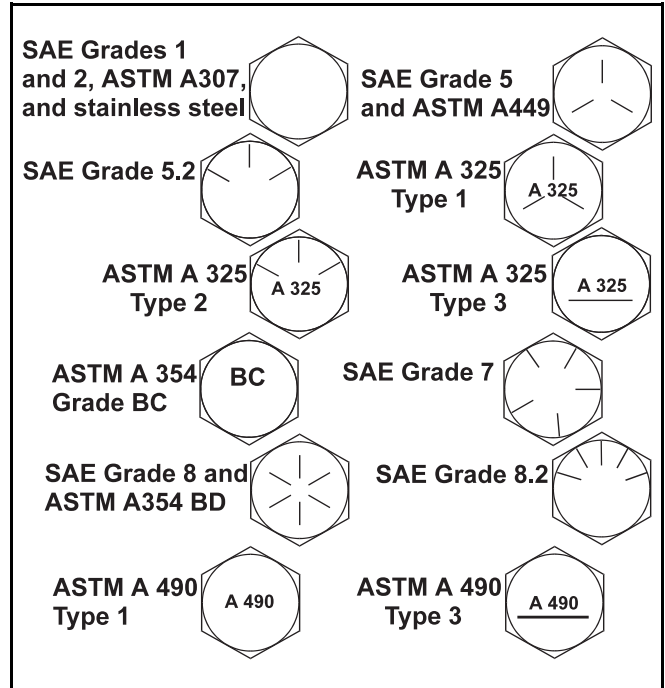

FIGURE 1 (MSSM0101CE)
Fastener Grade Markings

Fasteners and Threadlocker

How Fasteners Loosen—Standard threaded fasteners are manufactured with a clearance fit for easy assembly. With the fastener at the proper torque, 85% of the tightening torque is absorbed in the threads and under the fastener head. The remaining 15% provides the friction that prevents the thread from slipping. When this friction is overcome (by bending, thermal expansion, internal pressures, functional loads, or impact) the thread slips and loosens. Although higher torques reduce the likelihood of thread slippage, if slippage occurs, the threads unwind and the fastener loosens. Once thread slippage begins, vibration increases the rate of loosening.

Preventing Loosening—The most effective way to prevent loosening of threaded parts is by proper application of a threadlocking compound. Threadlocker provides lubrication during assembly, then hardens to seal the threads against corrosion and provide resistance to thread slippage.

Applying Threadlocker

NOTE: The following threadlocker information and illustrations are excerpts from the Loctite® User's Guide and are used with permission.

For maximum strength, threadlocker must fill the thread voids completely, as shown in FIGURE 2. Organic or petroleum solvent will remove excess uncured adhesive from joints. Consult information below for the specific fastener application.

Bolts and Nuts—See FIGURE 3.

1. Clean all threads (bolt and nut) with cleaning solvent.
2. Spray all threads with Loctite® Primer N. Allow to dry.
3. Insert bolt into through hole assembly.
4. Apply several drops of threadlocker onto bolt engagement area.
5. Assemble and tighten nut to correct torque for the threadlocker.

Blind Holes—See FIGURE 4.

1. Clean all threads (bolt and nut) with cleaning solvent.
2. Spray all threads with Loctite® Primer N. Allow to dry.
3. Squirt several drops down female threads into bottom of hole.
4. Apply several drops to bolt.
5. Tighten to correct torque for the threadlocker.

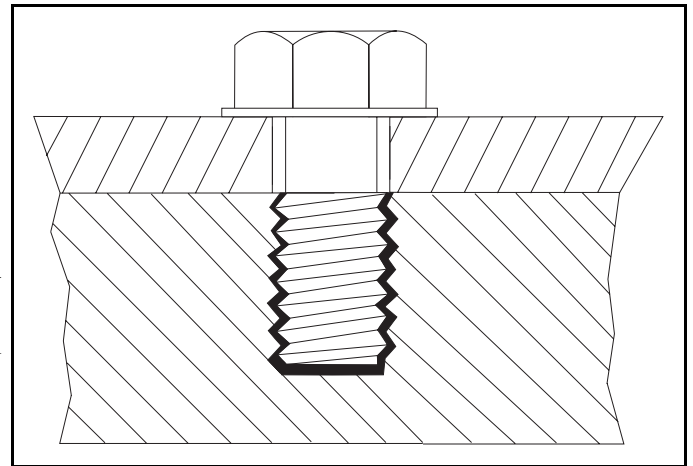

FIGURE 2 (MSSM0101CE)
Correct Threadlocker Use

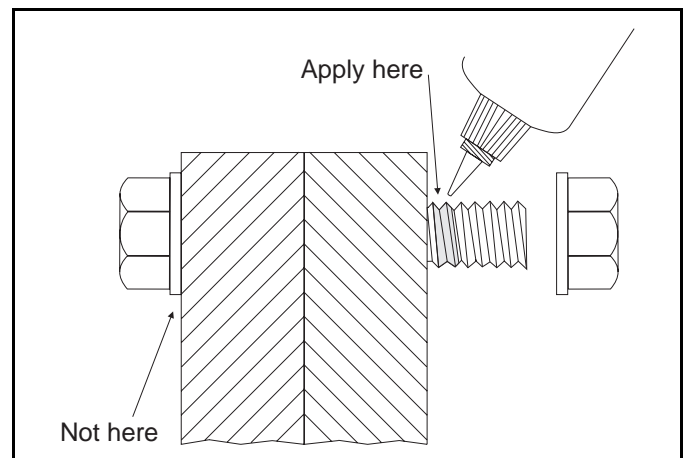

FIGURE 3 (MSSM0101CE)
Applying Threadlocker to Through Hole

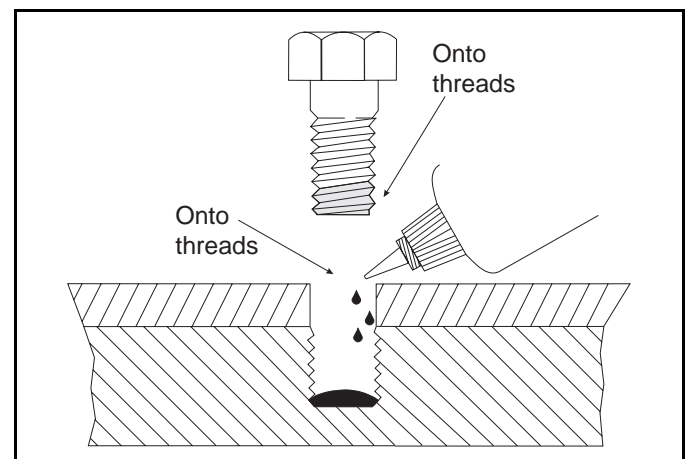

FIGURE 4 (MSSM0101CE)
Applying Threadlocker to Blind Holes

Removing Fasteners

High strength threadlockers like Loctite[®] 271 (or equivalent) may be weakened by heating to at least 500° F (260° C) as follows.

1. Apply localized heat to fastener as shown in FIGURE 5.
2. Disassemble while hot. Once disassembled, the cured adhesive can be removed with Loctite[®] Gasket Remover #790 (or equivalent).

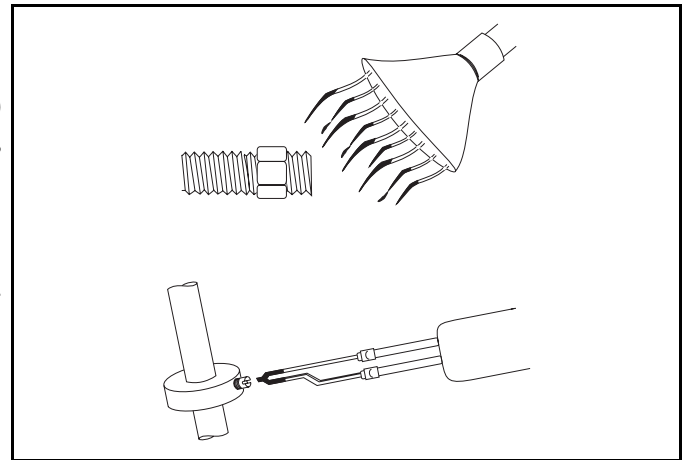

FIGURE 5 (MSSM0101CE)
Removing High Strength Threadlocker

Carbon Steel Fasteners

All values in foot pounds and (Newton meters)

Nominal bolt size	Grade Designation and Standard	Zinc or Cadmium Plated	If instructions call for :					
			Loctite 222 or 262	Loctite 242	Loctite 271	Loctite 272	Loctite 277	Bare
1/4 - 20	SAE Grade 1 ASTM A307	2.5 (3.39)	3.0 (4.06)	3.3 (4.47)	3.6 (4.88)	4.6 (6.23)	4.3 (5.83)	3.3 (4.47)
	SAE Grade 2	4.1 (5.56)	4.9 (6.64)	5.5 (7.45)	6.0 (8.13)	7.7 (10.44)	7.1 (9.63)	5.5 (7.46)
	SAE Grade 4	4.8 (6.50)	5.8 (7.86)	6.4 (8.67)	7.0 (9.49)	9.0 (12.20)	8.3 (11.25)	6.4 (8.67)
	SAE Grade 5 ASTM A449	6.3 (8.54)	7.6 (10.3)	8.4 (11.38)	9.3 (12.60)	11.8 (15.99)	11.0 (14.91)	8.4 (11.39)
	SAE Grade 7	7.9 (10.7)	9.4 (12.7)	10.5 (14.23)	11.5 (15.59)	14.7 (19.93)	13.6 (18.44)	10.5 (14.23)
	SAE Grade 8 ASTM A354 Grade BD	8.9 (12.0)	10.7 (14.5)	11.9 (16.13)	13.1 (17.76)	16.6 (22.50)	15.4 (20.88)	11.9 (16.13)
	ASTM A354 Grade BC	7.9 (10.7)	9.4 (12.7)	10.5 (14.23)	11.5 (15.59)	14.7 (19.93)	13.6 (18.44)	10.5 (14.23)

All values in foot pounds and (Newton meters)

Nominal bolt size	Grade Designation and Standard	Zinc or Cadmium Plated	If instructions call for :					Bare
			Loctite 222 or 262	Loctite 242	Loctite 271	Loctite 272	Loctite 277	
1/4 - 28	SAE Grade 1 ASTM A307	2.8 (3.80)	3.4 (4.61)	3.8 (5.15)	4.1 (5.56)	5.3 (7.18)	4.9 (6.64)	3.8 (5.15)
	SAE Grade 2	4.7 (6.37)	5.6 (7.60)	6.3 (8.54)	6.9 (9.36)	8.8 (11.93)	8.1 (10.98)	6.3 (8.54)
	SAE Grade 4	5.5 (7.46)	6.6 (8.95)	7.3 (9.90)	8.1 (10.98)	10.3 (13.96)	9.5 (12.88)	7.3 (9.90)
	SAE Grade 5 ASTM A449	7.3 (9.90)	8.7 (11.80)	9.7 (13.15)	10.7 (14.50)	13.6 (18.44)	12.6 (17.08)	9.7 (13.15)
	SAE Grade 7	8.9 (12.07)	10.7 (14.50)	11.9 (16.13)	13.1 (17.76)	16.6 (22.51)	15.4 (20.88)	11.9 (16.13)
	SAE Grade 8 ASTM A354 Grade BD	10.2 (13.83)	12.2 (16.54)	13.6 (18.44)	15.0 (20.34)	19.0 (25.76)	17.7 (23.99)	13.6 (18.44)
	ASTM A354 Grade BC	—	—	—	—	—	—	—

All values in foot pounds and (Newton meters)

Nominal bolt size	Grade Designation and Standard	Zinc or Cadmium Plated	If instructions call for :					Bare
			Loctite 222 or 262	Loctite 242	Loctite 271	Loctite 272	Loctite 277	
5/16 - 18	SAE Grade 1 ASTM A307	5.1 (6.91)	6.2 (8.40)	6.8 (9.22)	7.5 (10.17)	9.6 (13.02)	8.9 (12.07)	6.8 (9.22)
	SAE Grade 2	8.5 (11.52)	10.2 (13.83)	11.3 (15.32)	12.5 (16.95)	15.9 (21.56)	14.7 (19.93)	11.3 (15.32)
	SAE Grade 4	10.0 (13.56)	12.0 (16.27)	13.3 (18.03)	14.6 (19.79)	18.6 (25.22)	17.3 (23.46)	13.3 (18.03)
	SAE Grade 5 ASTM A449	13.0 (17.63)	15.6 (21.15)	17.4 (23.60)	19.1 (25.90)	24.3 (32.95)	22.6 (30.64)	17.4 (23.60)
	SAE Grade 7	16.1 (21.83)	19.3 (26.17)	21.5 (29.15)	23.6 (31.99)	30.1 (40.81)	27.9 (37.83)	21.5 (29.15)
	SAE Grade 8 ASTM A354 Grade BD	18.5 (25.08)	22.1 (29.96)	24.6 (33.35)	27.1 (36.74)	34.5 (46.78)	32.0 (43.39)	24.6 (33.35)
	ASTM A354 Grade BC	16.1 (21.83)	19.3 (26.17)	21.5 (29.15)	23.6 (31.99)	30.1 (40.81)	27.9 (37.83)	21.5 (29.15)

All values in foot pounds and (Newton meters)

Nominal bolt size	Grade Designation and Standard	Zinc or Cadmium Plated	If instructions call for :					
			Loctite 222 or 262	Loctite 242	Loctite 271	Loctite 272	Loctite 277	Bare
5/16 - 24	SAE Grade 1 ASTM A307	5.6 (7.59)	6.7 (9.08)	7.4 (10.03)	8.2 (11.12)	10.4 (14.10)	9.6 (13.01)	7.4 (10.03)
	SAE Grade 2	9.4 (12.74)	11.3 (15.32)	12.5 (16.94)	13.8 (18.71)	17.5 (23.73)	16.3 (22.09)	12.5 (16.94)
	SAE Grade 4	11.0 (14.91)	13.2 (17.90)	14.6 (19.79)	16.1 (21.83)	20.5 (27.79)	19.0 (25.76)	14.6 (19.79)
	SAE Grade 5 ASTM A449	14.4 (19.52)	17.2 (23.32)	19.1 (25.90)	21.1 (28.60)	26.8 (36.35)	24.9 (33.76)	19.1 (25.90)
	SAE Grade 7	17.9 (24.27)	21.4 (29.01)	23.8 (32.27)	26.2 (35.52)	33.4 (45.28)	31.0 (42.03)	23.8 (32.27)
	SAE Grade 8 ASTM A354 Grade BD	20.4 (27.66)	24.4 (33.08)	27.1 (36.74)	29.9 (40.54)	38.0 (51.52)	35.3 (47.86)	27.1 (36.74)
	ASTM A354 Grade BC	—	—	—	—	—	—	—

All values in foot pounds and (Newton meters)

Nominal bolt size	Grade Designation and Standard	Zinc or Cadmium Plated	If instructions call for :					
			Loctite 222 or 262	Loctite 242	Loctite 271	Loctite 272	Loctite 277	Bare
3/8 - 16	SAE Grade 1 ASTM A307	9.0 (12.20)	10.8 (14.64)	12.0 (16.27)	13.1 (17.76)	16.7 (22.64)	15.5 (21.01)	12.0 (16.27)
	SAE Grade 2	14.9 (20.20)	17.9 (24.27)	19.9 (26.98)	21.9 (29.69)	27.9 (37.83)	25.9 (35.11)	19.9 (26.98)
	SAE Grade 4	17.8 (24.13)	21.3 (28.88)	23.7 (32.13)	26.0 (35.25)	33.1 (44.87)	30.8 (41.76)	23.7 (32.13)
	SAE Grade 5 ASTM A449	23.2 (31.45)	27.8 (37.69)	30.9 (41.89)	34.0 (46.09)	43.3 (58.70)	40.2 (54.50)	30.9 (41.89)
	SAE Grade 7	28.7 (38.91)	34.4 (46.64)	38.2 (51.79)	42.0 (56.94)	53.5 (72.54)	49.7 (67.39)	38.2 (51.79)
	SAE Grade 8 ASTM A354 Grade BD	32.7 (44.33)	39.2 (53.15)	43.6 (59.11)	48.0 (65.08)	61.0 (82.70)	56.7 (76.87)	43.6 (59.11)
	ASTM A354 Grade BC	28.7 (38.91)	34.4 (46.64)	38.2 (51.79)	42.0 (56.94)	53.5 (72.54)	49.7 (67.39)	38.2 (51.79)

All values in foot pounds and (Newton meters)

Nominal bolt size	Grade Designation and Standard	Zinc or Cadmium Plated	If instructions call for :					
			Loctite 222 or 262	Loctite 242	Loctite 271	Loctite 272	Loctite 277	Bare
3/8 - 24	SAE Grade 1 ASTM A307	10.2 (13.83)	12.2 (16.54)	13.6 (18.44)	15.0 (20.33)	19.0 (25.76)	17.7 (24.00)	13.6 (18.44)
	SAE Grade 2	16.9 (22.91)	20.3 (27.52)	22.5 (30.52)	24.8 (33.62)	31.5 (42.70)	29.3 (39.73)	22.5 (30.50)
	SAE Grade 4	20.0 (27.11)	24.0 (32.54)	26.7 (36.20)	29.4 (39.86)	37.4 (50.70)	34.7 (47.04)	26.7 (36.20)
	SAE Grade 5 ASTM A449	26.2 (35.52)	31.4 (42.57)	34.9 (47.32)	38.4 (52.06)	48.9 (66.30)	45.4 (61.55)	34.9 (47.32)
	SAE Grade 7	32.3 (43.79)	38.8 (52.60)	43.1 (58.44)	47.4 (64.26)	60.4 (81.89)	56.1 (76.06)	43.1 (58.43)
	SAE Grade 8 ASTM A354 Grade BD	36.9 (50.02)	44.3 (60.06)	49.2 (66.70)	54.1 (73.35)	68.9 (93.41)	64.0 (86.77)	49.2 (66.70)
	ASTM A354 Grade BC	—	—	—	—	—	—	—

All values in foot pounds and (Newton meters)

Nominal bolt size	Grade Designation and Standard	Zinc or Cadmium Plated	If instructions call for :					
			Loctite 222 or 262	Loctite 242	Loctite 271	Loctite 272	Loctite 277	Bare
7/16 - 14	SAE Grade 1 ASTM A307	14.0 (18.98)	17.0 (23.04)	19.14 (25.95)	21.0 (28.47)	27.0 (36.60)	25.0 (33.89)	19.0 (25.76)
	SAE Grade 2	24.0 (32.54)	28.8 (39.05)	32.0 (43.39)	35.2 (47.72)	44.8 (60.74)	41.6 (56.40)	32.0 (43.39)
	SAE Grade 4	28.3 (38.37)	34.0 (46.10)	37.7 (51.11)	41.5 (56.27)	52.8 (71.59)	49.1 (66.57)	37.7 (51.11)
	SAE Grade 5 ASTM A449	37.1 (50.30)	44.5 (60.33)	49.5 (67.11)	54.4 (73.76)	69.3 (93.96)	64.3 (87.18)	49.5 (67.11)
	SAE Grade 7	45.9 (62.23)	55.1 (74.70)	61.3 (83.11)	67.4 (91.38)	85.8 (116.33)	79.6 (107.92)	61.3 (83.11)
	SAE Grade 8 ASTM A354 Grade BD	52.5 (71.18)	63.0 (85.41)	70.0 (94.90)	77.0 (104.40)	98.0 (132.87)	91.0 (123.38)	70.0 (94.90)
	ASTM A354 Grade BC	45.7 (61.96)	54.9 (74.43)	61.0 (82.70)	67.1 (90.97)	85.4 (115.79)	79.3 (107.52)	61.0 (82.70)

All values in foot pounds and (Newton meters)

Nominal bolt size	Grade Designation and Standard	Zinc or Cadmium Plated	If instructions call for :					
			Loctite 222 or 262	Loctite 242	Loctite 271	Loctite 272	Loctite 277	Bare
7/16 - 20	SAE Grade 1 ASTM A307	16.0 (21.70)	19.2 (26.03)	21.3 (28.88)	23.5 (31.86)	29.9 (40.54)	27.7 (37.56)	21.3 (28.88)
	SAE Grade 2	26.9 (36.48)	32.2 (43.66)	35.8 (48.54)	39.4 (53.42)	50.1 (67.93)	46.6 (63.18)	35.8 (48.54)
	SAE Grade 4	31.6 (42.84)	37.9 (51.39)	42.1 (57.08)	46.3 (62.77)	59.0 (79.99)	54.7 (74.16)	42.1 (57.08)
	SAE Grade 5 ASTM A449	41.4 (56.13)	49.7 (67.38)	55.2 (74.84)	60.8 (82.43)	77.3 (104.80)	71.8 (97.35)	55.2 (74.84)
	SAE Grade 7	51.3 (69.55)	61.5 (83.38)	68.4 (92.74)	75.2 (101.96)	95.7 (129.75)	88.9 (120.53)	68.4 (92.74)
	SAE Grade 8 ASTM A354 Grade BD	58.2 (78.90)	69.9 (94.77)	77.7 (105.35)	85.4 (115.78)	108.7 (147.37)	101.0 (136.94)	77.7 (105.35)
	ASTM A354 Grade BC	—	—	—	—	—	—	—

All values in foot pounds and (Newton meters)

Nominal bolt size	Grade Designation and Standard	Zinc or Cadmium Plated	If instructions call for :					
			Loctite 222 or 262	Loctite 242	Loctite 271	Loctite 272	Loctite 277	Bare
1/2 - 13	SAE Grade 1 ASTM A307	22.0 (29.83)	26.0 (35.25)	29.38 (39.83)	32.0 (43.39)	41.0 (55.59)	38.0 (51.52)	29.0 (39.32)
	SAE Grade 2	36.6 (49.62)	43.9 (59.52)	48.8 (66.16)	53.6 (72.67)	68.3 (92.60)	63.4 (85.96)	48.8 (66.16)
	SAE Grade 4	43.1 (58.44)	51.8 (70.23)	57.5 (77.96)	63.3 (85.82)	80.5 (109.14)	74.8 (101.42)	57.5 (77.96)
	SAE Grade 5 ASTM A449	56.7 (76.87)	68.1 (92.33)	75.6 (102.5)	83.2 (112.80)	105.9 (143.58)	98.3 (133.27)	75.6 (102.50)
	SAE Grade 7	69.8 (94.64)	83.8 (113.62)	93.1 (126.23)	102.4 (138.84)	130.4 (176.80)	121.1 (164.19)	93.1 (126.23)
	SAE Grade 8 ASTM A354 Grade BD	79.7 (108.05)	95.6 (129.62)	106.3 (144.12)	116.9 (158.50)	148.8 (201.75)	138.1 (187.24)	106.3 (144.12)
	ASTM A354 Grade BC	69.8 (94.64)	83.8 (113.62)	93.1 (126.23)	102.4 (138.84)	130.4 (176.80)	121.1 (164.19)	93.1 (126.23)

All values in foot pounds and (Newton meters)

Nominal bolt size	Standard and Grade Designation	Zinc or Cadmium Plated	If instructions call for :					
			Loctite 222 or 262	Loctite 242	Loctite 271	Loctite 272	Loctite 277	Bare
1/2 - 20	SAE Grade 1 ASTM A307	24.8 (33.62)	29.8 (40.40)	33.1 (44.88)	36.4 (49.35)	46.4 (62.91)	43.1 (58.44)	33.1 (44.88)
	SAE Grade 2	41.3 (56.00)	49.5 (67.11)	55.0 (74.57)	60.5 (82.02)	77.0 (104.40)	71.5 (96.94)	55.0 (74.57)
	SAE Grade 4	48.8 (66.16)	58.5 (79.32)	65.0 (88.13)	71.5 (96.94)	91.0 (123.38)	84.5 (114.57)	65.0 (88.13)
	SAE Grade 5 ASTM A449	63.8 (86.50)	76.5 (103.72)	85.0 (115.24)	93.5 (126.77)	119.0 (161.34)	110.5 (149.82)	85.0 (115.24)
	SAE Grade 7	78.8 (106.84)	94.5 (128.12)	105.0 (142.36)	115.5 (156.60)	147.0 (199.30)	136.5 (185.07)	105.0 (142.36)
	SAE Grade 8 ASTM A354 Grade BD	90.0 (122.02)	108.0 (146.43)	120.0 (162.70)	132.0 (179.00)	168.0 (277.78)	156.0 (211.51)	120.0 (162.70)
	ASTM A354 Grade BC	—	—	—	—	—	—	—

All values in foot pounds and (Newton meters)

Nominal bolt size	Grade Designation and Standard	Zinc or Cadmium Plated	If instructions call for :					
			Loctite 222 or 262	Loctite 242	Loctite 271	Loctite 272	Loctite 277	Bare
9/16 - 12	SAE Grade 1 ASTM A307	32.0 (43.39)	38.0 (51.52)	42.19 (57.20)	46.0 (62.37)	59.0 (80.00)	55.0 (74.57)	42 (56.94)
	SAE Grade 2	52.7 (71.45)	63.3 (85.82)	70.3 (95.31)	77.3 (104.80)	98.4 (133.41)	91.4 (123.92)	70.3 (95.31)
	SAE Grade 4	62.2 (84.33)	74.7 (101.28)	83.0 (112.53)	91.3 (123.79)	116.2 (157.55)	107.9 (146.30)	83.0 (112.53)
	SAE Grade 5 ASTM A449	81.7 (110.77)	98.1 (133.00)	109.0 (147.78)	119.9 (162.56)	152.6 (206.90)	141.7 (192.17)	109.0 (147.78)
	SAE Grade 7	100.7 (136.53)	120.9 (163.92)	134.3 (182.09)	147.7 (200.25)	188.0 (254.89)	174.6 (236.73)	134.3 (182.09)
	SAE Grade 8 ASTM A354 Grade BD	115.0 (155.92)	138.0 (187.10)	153.3 (207.85)	168.6 (228.59)	214.6 (290.96)	199.3 (270.21)	153.3 (207.85)
	ASTM A354 Grade BC	100.7 (136.53)	120.9 (163.92)	134.3 (182.09)	147.7 (200.25)	188.0 (254.89)	174.6 (236.73)	134.3 (182.09)

All values in foot pounds and (Newton meters)

Nominal bolt size	Grade Designation and Standard	Zinc or Cadmium Plated	If instructions call for:					
			Loctite 222 or 262	Loctite 242	Loctite 271	Loctite 272	Loctite 277	Bare
9/16 - 18	SAE Grade 1 ASTM A307	35.3 (47.86)	42.4 (57.49)	47.1 (63.86)	51.8 (70.23)	66.0 (89.48)	61.2 (82.98)	47.1 (63.86)
	SAE Grade 2	59.1 (80.13)	70.9 (96.13)	78.8 (106.84)	86.6 (117.41)	110.3 (149.55)	102.4 (138.84)	78.8 (106.84)
	SAE Grade 4	69.6 (94.36)	83.5 (113.21)	92.8 (125.82)	102.1 (138.43)	129.9 (176.12)	120.7 (163.65)	92.8 (125.85)
	SAE Grade 5 ASTM A449	91.2 (123.65)	109.5 (148.46)	121.6 (164.87)	133.8 (181.40)	170.3 (230.90)	158.1 (214.36)	121.6 (164.87)
	SAE Grade 7	112.3 (152.26)	134.8 (182.76)	149.8 (203.10)	164.7 (223.30)	209.7 (284.32)	194.7 (263.98)	149.8 (203.10)
	SAE Grade 8 ASTM A354 Grade BD	128.7 (174.61)	154.4 (209.34)	171.6 (232.66)	188.7 (255.84)	240.2 (325.67)	223.0 (302.35)	171.6 (232.66)
	ASTM A354 Grade BC	—	—	—	—	—	—	—

All values in foot pounds and (Newton meters)

Nominal bolt size	Grade Designation and Standard	Zinc or Cadmium Plated	If instructions call for:					
			Loctite 222 or 262	Loctite 242	Loctite 271	Loctite 272	Loctite 277	Bare
5/8 - 11	SAE Grade 1 ASTM A307	44 (59.66)	52 (70.50)	58.2 (78.90)	64 (86.77)	81 (109.82)	76 (103.04)	58 (78.64)
	SAE Grade 2	72.7 (98.57)	87.2 (118.23)	96.9 (131.38)	106.6 (144.53)	135.6 (183.85)	125.9 (170.70)	96.9 (131.38)
	SAE Grade 4	86.1 (116.74)	103.4 (140.19)	114.8 (155.65)	126.3 (171.24)	160.8 (218.02)	149.3 (202.42)	114.8 (155.65)
	SAE Grade 5 ASTM A449	112.5 (152.53)	135.0 (183.04)	150.0 (203.37)	165.0 (223.71)	210.0 (284.72)	195.0 (264.38)	150.0 (203.37)
	SAE Grade 7	138.9 (188.32)	166.6 (225.88)	185.2 (251.10)	203.7 (276.18)	259.2 (351.43)	240.7 (326.35)	185.2 (251.10)
	SAE Grade 8 ASTM A354 Grade BD	158.8 (215.30)	190.5 (258.28)	211.7 (287.03)	232.9 (315.77)	296.4 (401.86)	275.2 (373.12)	211.7 (287.03)
	ASTM A354 Grade BC	139.2 (188.73)	167.0 (226.42)	185.5 (251.50)	204.1 (276.72)	259.8 (352.24)	241.2 (327.02)	185.5 (251.50)

All values in foot pounds and (Newton meters)

Nominal bolt size	Grade Designation and Standard	Zinc or Cadmium Plated	If instructions call for:					
			Loctite 222 or 262	Loctite 242	Loctite 271	Loctite 272	Loctite 277	Bare
5/8 - 18	SAE Grade 1 ASTM A307	49.5 (67.11)	59.4 (80.54)	66.0 (89.48)	72.6 (98.43)	92.4 (125.27)	85.8 (116.33)	66.0 (89.48)
	SAE Grade 2	82.6 (112.00)	99.1 (134.36)	110.2 (149.41)	121.2 (164.33)	154.2 (209.07)	143.2 (194.15)	110.2 (149.41)
	SAE Grade 4	97.3 (131.92)	116.7 (158.22)	129.7 (175.85)	142.7 (193.48)	181.6 (246.22)	168.6 (228.59)	129.7 (175.85)
	SAE Grade 5 ASTM A449	127.7 (173.14)	153.3 (207.85)	170.3 (230.90)	187.3 (253.95)	238.4 (323.23)	221.4 (300.18)	170.3 (230.90)
	SAE Grade 7	157.6 (213.68)	189.1 (256.39)	210.2 (285.00)	231.2 (313.47)	294.2 (398.88)	273.2 (370.41)	210.2 (285.00)
	SAE Grade 8 ASTM A354 Grade BD	179.9 (243.91)	215.9 (292.72)	239.8 (325.13)	263.8 (357.66)	335.8 (455.28)	311.8 (422.74)	239.8 (325.13)
	ASTM A354 Grade BC	—	—	—	—	—	—	—

All values in foot pounds and (Newton meters)

Nominal bolt size	Grade Designation and Standard	Zinc or Cadmium Plated	If instructions call for:					
			Loctite 222 or 262	Loctite 242	Loctite 271	Loctite 272	Loctite 277	Bare
3/4 - 10	SAE Grade 1 ASTM A307	77 (104.40)	93 (126.09)	103.1 (139.78)	113 (153.20)	144 (195.24)	134 (181.68)	103 (139.65)
	SAE Grade 2	129.4 (175.44)	155.3 (210.55)	172.5 (233.88)	189.8 (257.33)	241.5 (327.43)	224.3 (304.11)	172.5 (233.88)
	SAE Grade 4	152.6 (206.90)	183.1 (248.25)	203.4 (275.77)	223.8 (303.43)	284.8 (386.14)	264.5 (358.61)	203.4 (275.77)
	SAE Grade 5 ASTM A449	199.7 (270.76)	239.6 (324.85)	266.3 (361.05)	292.9 (397.12)	372.8 (505.45)	346.1 (469.25)	266.3 (361.05)
	SAE Grade 7	246.8 (334.62)	296.2 (401.60)	329.1 (446.20)	362.0 (490.13)	460.7 (624.63)	427.8 (580.02)	329.1 (446.20)
	SAE Grade 8 ASTM A354 Grade BD	282.0 (382.34)	338.3 (458.67)	375.9 (509.65)	413.5 (560.63)	526.3 (713.57)	488.7 (662.59)	375.9 (509.65)
	ASTM A354 Grade BC	246.4 (334.07)	295.7 (400.92)	328.6 (445.53)	361.5 (490.13)	460.0 (623.67)	427.2 (579.20)	328.6 (445.53)

All values in foot pounds and (Newton meters)

Nominal bolt size	Grade Designation and Standard	Zinc or Cadmium Plated	If instructions call for:					
			Loctite 222 or 262	Loctite 242	Loctite 271	Loctite 272	Loctite 277	Bare
3/4 - 16	SAE Grade 1 ASTM A307	86.5 (117.28)	103.8 (140.73)	115.3 (156.33)	126.8 (171.92)	161.4 (218.83)	149.9 (203.24)	115.3 (156.33)
	SAE Grade 2	144.1 (195.37)	173.0 (234.56)	192.2 (260.59)	211.4 (286.62)	269.1 (364.85)	249.8 (338.68)	192.2 (260.59)
	SAE Grade 4	170.2 (230.76)	204.2 (276.86)	226.9 (307.64)	249.6 (338.41)	317.6 (430.61)	294.9 (399.15)	226.9 (307.64)
	SAE Grade 5 ASTM A449	222.9 (302.21)	267.5 (362.68)	297.2 (402.95)	326.9 (443.22)	416.1 (564.16)	386.3 (523.75)	297.2 (402.95)
	SAE Grade 7	275.6 (373.66)	330.8 (448.50)	367.5 (498.26)	404.3 (548.16)	514.5 (697.57)	477.8 (647.81)	367.5 (498.26)
	SAE Grade 8 ASTM A354 Grade BD	315.0 (427.08)	378.0 (512.50)	420.0 (569.44)	462.0 (626.39)	588.0 (797.22)	546.0 (740.28)	420.0 (569.44)
	ASTM A354 Grade BC	—	—	—	—	—	—	—

All values in foot pounds and (Newton meters)

Nominal bolt size	Grade Designation and Standard	Zinc or Cadmium Plated	If instructions call for:					
			Loctite 222 or 262	Loctite 242	Loctite 271	Loctite 272	Loctite 277	Bare
7/8 - 9	SAE Grade 1 ASTM A307	124.7 (169.07)	149.6 (202.83)	166.3 (225.47)	182.9 (247.98)	232.8 (315.63)	216.1 (293.0)	166.3 (225.47)
	SAE Grade 2	124.7 (169.07)	149.6 (202.83)	166.3 (225.47)	182.9 (247.98)	232.8 (315.63)	216.1 (293.00)	166.3 (255.47)
	SAE Grade 4	246.1 (333.67)	295.3 (400.37)	328.1 (444.84)	360.9 (489.32)	459.4 (622.86)	426.6 (578.40)	328.1 (444.84)
	SAE Grade 5 ASTM A449	322.4 (437.11)	386.9 (524.57)	429.8 (582.73)	472.8 (641.03)	601.8 (815.93)	558.8 (757.63)	429.8 (582.73)
	SAE Grade 7	397.9 (539.48)	477.4 (647.27)	530.5 (719.26)	583.5 (791.12)	742.7 (1007.00)	689.6 (935.00)	530.5 (719.26)
	SAE Grade 8 ASTM A354 Grade BD	454.5 (616.22)	545.3 (739.33)	605.9 (821.49)	666.5 (903.65)	848.3 (1150.14)	787.7 (1067.98)	605.9 (821.49)
	ASTM A354 Grade BC	397.9 (539.48)	477.4 (647.27)	530.5 (719.26)	583.5 (791.12)	742.7 (1007.00)	689.6 (935.00)	530.5 (719.26)

All values in foot pounds and (Newton meters)

Nominal bolt size	Grade Designation and Standard	Zinc or Cadmium Plated	If instructions call for:					
			Loctite 222 or 262	Loctite 242	Loctite 271	Loctite 272	Loctite 277	Bare
7/8 - 14	SAE Grade 1 ASTM A307	137.8 (186.83)	165.4 (224.25)	183.8 (249.20)	202.1 (274.01)	257.3 (348.85)	238.9 (323.90)	183.8 (249.20)
	SAE Grade 2	137.8 (186.83)	165.4 (224.25)	183.8 (249.20)	202.1 (274.01)	257.3 (348.85)	238.9 (323.90)	183.8 (249.20)
	SAE Grade 4	271.5 (368.11)	325.8 (441.73)	362.0 (490.80)	398.2 (539.89)	506.8 (687.13)	470.6 (638.05)	362.0 (490.80)
	SAE Grade 5 ASTM A449	355.2 (481.59)	426.2 (577.85)	473.6 (642.12)	521.0 (706.38)	663.0 (898.91)	615.7 (834.78)	473.6 (642.12)
	SAE Grade 7	438.0 (593.85)	525.7 (712.75)	584.1 (791.93)	642.5 (871.11)	817.7 (1108.65)	759.3 (1029.47)	584.1 (791.93)
	SAE Grade 8 ASTM A354 Grade BD	501.2 (679.54)	601.5 (815.53)	668.3 (906.09)	735.1 (996.66)	935.6 (1268.50)	868.8 (1177.94)	668.3 (906.09)
	ASTM A354 Grade BC	—	—	—	—	—	—	—

All values in foot pounds and (Newton meters)

Nominal bolt size	Grade Designation and Standard	Zinc or Cadmium Plated	If instructions call for:					
			Loctite 222 or 262	Loctite 242	Loctite 271	Loctite 272	Loctite 277	Bare
1 - 8	SAE Grade 1 ASTM A307	187.5 (254.22)	225.0 (305.06)	250.0 (338.95)	275.0 (372.85)	350.0 (474.54)	325.0 (440.64)	250.0 (338.95)
	SAE Grade 2	187.5 (254.22)	225.0 (305.06)	250.0 (338.95)	275.0 (372.85)	350.0 (474.54)	325.0 (440.64)	250.0 (338.95)
	SAE Grade 4	369.4 (500.84)	443.3 (601.03)	492.5 (667.74)	541.8 (734.58)	689.5 (934.84)	640.3 (868.13)	492.5 (667.74)
	SAE Grade 5 ASTM A449	482.8 (654.59)	579.4 (785.56)	643.8 (872.88)	708.1 (960.05)	901.3 (1222.00)	836.9 (1134.69)	643.8 (872.88)
	SAE Grade 7	596.3 (808.47)	715.5 (970.09)	795.0 (1077.88)	874.5 (1185.66)	1113.0 (1509.03)	1033.5 (1401.24)	795.0 (1077.88)
	SAE Grade 8 ASTM A354 Grade BD	681.6 (924.13)	817.9 (1108.92)	908.8 (1232.17)	999.6 (1355.28)	1272.3 (1725.00)	1181.4 (1601.77)	908.8 (1232.17)
	ASTM A354 Grade BC	596.7 (809.01)	716.1 (970.90)	795.6 (1078.69)	875.2 (1186.61)	1113.9 (1510.25)	1034.3 (1402.32)	795.6 (1078.69)

All values in foot pounds and (Newton meters)

Nominal bolt size	Grade Designation and Standard	Zinc or Cadmium Plated	If instructions call for :					
			Loctite 222 or 262	Loctite 242	Loctite 271	Loctite 272	Loctite 277	Bare
1 - 12	SAE Grade 1 ASTM A307	205.3 278.35	246.4 (334.07)	273.8 (371.22)	301.1 (408.24)	383.3 (519.69)	355.9 (482.54)	273.8 (371.22)
	SAE Grade 2	205.3 (278.35)	246.4 (334.07)	273.8 (371.22)	301.1 (408.24)	383.3 (519.69)	355.9 (482.54)	273.8 (371.22)
	SAE Grade 4	404.1 (547.88)	484.9 (657.44)	538.8 (730.52)	592.6 (803.46)	754.3 (1022.70)	700.4 (949.62)	538.8 (730.52)
	SAE Grade 5 ASTM A449	528.8 (716.96)	634.5 (860.27)	705.0 (955.85)	775.5 (1051.44)	987.0 (1338.19)	916.5 (1242.61)	705.0 (955.85)
	SAE Grade 7	652.5 (884.67)	783.0 (1061.60)	870.0 (1179.56)	957.0 (1297.52)	1218.0 (1651.39)	1131.0 (1533.42)	870.0 (1179.56)
	SAE Grade 8 ASTM A354 Grade BD	746.3 (1011.85)	895.5 (1214.14)	995.0 (1349.04)	1094.5 (1483.49)	1393.0 (1888.66)	1293.5 (1753.73)	995.0 (1349.04)
	ASTM A354 Grade BC	—	—	—	—	—	—	—

All values in foot pounds and (Newton meters)

Nominal bolt size	Grade Designation and Standard	Zinc or Cadmium Plated	If instructions call for :					
			Loctite 222 or 262	Loctite 242	Loctite 271	Loctite 272	Loctite 277	Bare
1 - 14	SAE Grade 1 ASTM A307	210.0 (284.72)	252.0 (341.66)	280.0 (379.63)	308.0 (417.60)	392.0 (531.48)	364.0 (493.52)	280.0 (379.63)
	SAE Grade 2	210.0 (284.72)	252.0 (341.66)	280.0 (379.63)	308.0 (417.60)	392.0 (531.48)	364.0 (493.52)	280.0 (379.63)
	SAE Grade 4	413.4 (560.50)	496.1 (672.62)	551.3 (747.46)	606.4 (822.17)	771.8 (1046.42)	716.6 (971.58)	551.3 (747.46)
	SAE Grade 5 ASTM A449	540.9 (733.36)	649.1 (880.06)	721.3 (977.95)	793.4 (1075.70)	1009.8 (1369.10)	937.6 (1271.22)	721.3 (977.95)
	SAE Grade 7	668.4 (906.23)	802.1 (1087.50)	891.3 (1208.44)	980.4 (1329.25)	1247.8 (1691.79)	1158.6 (1570.85)	891.3 (1208.44)
	SAE Grade 8 ASTM A354 Grade BD	764.1 (1035.98)	916.9 (1243.15)	1018.8 (1381.31)	1120.6 (1519.33)	1426.3 (1933.80)	1324.4 (1795.65)	1018.8 (1381.30)
	ASTM A354 Grade BC	—	—	—	—	—	—	—

All values in foot pounds and (Newton meters)

Nominal bolt size	Grade Designation and Standard	Zinc or Cadmium Plated	If instructions call for :					
			Loctite 222 or 262	Loctite 242	Loctite 271	Loctite 272	Loctite 277	Bare
1-1/8 • 7	SAE Grade 1 ASTM A307	265.8 (360.37)	318.9 (432.37)	354.4 (480.50)	389.8 (528.50)	496.1 (672.62)	460.7 (624.63)	354.4 (480.50)
	SAE Grade 2	265.8 (360.37)	318.9 (432.37)	354.4 (480.50)	389.8 (528.50)	496.1 (672.62)	460.7 (624.63)	354.4 (480.50)
	SAE Grade 4	523.1 (709.23)	627.8 (851.18)	697.5 (945.68)	767.3 (1040.32)	976.5 (1323.96)	906.8 (1229.46)	697.5 (945.68)
	SAE Grade 5 ASTM A449	595.9 (807.93)	715.1 (969.55)	794.5 (1077.20)	874.0 (1184.99)	1112.3 (1508.07)	1032.9 (1400.43)	794.5 (1077.20)
	SAE Grade 7	844.8 (1145.40)	1013.8 (1374.53)	1126.4 (1527.20)	1239.0 (1679.86)	1577.0 (2138.13)	1464.3 (1985.33)	1126.4 (1527.20)
	SAE Grade 8 ASTM A354 Grade BD	966.1 (1309.86)	1159.3 (1571.80)	1288.1 (1746.43)	1416.9 (1921.06)	1803.4 (2445.08)	1674.6 (2270.46)	1288.1 (1746.43)
	ASTM A354 Grade BC	844.8 (1145.40)	1013.8 (1374.53)	1126.4 (1527.20)	1239.0 (1679.86)	1577.0 (2138.13)	1464.3 (1985.33)	1126.4 (1527.20)

All values in foot pounds and (Newton meters)

Nominal bolt size	Grade Designation and Standard	Zinc or Cadmium Plated	If instructions call for :					
			Loctite 222 or 262	Loctite 242	Loctite 271	Loctite 272	Loctite 277	Bare
1-1/8 • 12	SAE Grade 1 ASTM A307	297.4 (403.22)	356.9 (483.89)	396.6 (537.72)	436.2 (591.40)	555.2 (752.75)	515.5 (698.93)	396.6 (537.72)
	SAE Grade 2	297.4 (403.22)	356.9 (483.89)	396.6 (537.72)	436.2 (591.40)	555.2 (752.75)	515.5 (698.93)	396.6 (537.72)
	SAE Grade 4	586.4 (795.05)	703.7 (954.09)	781.9 (1060.12)	860.1 (1166.14)	1094.6 (1484.08)	1016.4 (1378.06)	781.9 (1060.12)
	SAE Grade 5 ASTM A449	667.6 (905.14)	801.1 (1086.15)	890.2 (1206.95)	979.2 (1327.62)	1246.2 (1689.62)	1157.2 (1568.95)	890.2 (1206.95)
	SAE Grade 7	948.2 (1285.58)	1137.8 (1542.65)	1264.2 (1714.02)	1390.6 (1855.40)	1769.9 (2399.66)	1643.5 (2228.30)	1264.2 (1714.02)
	SAE Grade 8 ASTM A354 Grade BD	1083.2 (1468.62)	1299.8 (1762.30)	1444.2 (1958.07)	1588.6 (2153.85)	2021.9 (2741.33)	1877.5 (2545.55)	1444.2 (1958.07)
	ASTM A354 Grade BC	—	—	—	—	—	—	—

All values in foot pounds and (Newton meters)

Nominal bolt size	Grade Designation and Standard	Zinc or Cadmium Plated	If instructions call for :					
			Loctite 222 or 262	Loctite 242	Loctite 271	Loctite 272	Loctite 277	Bare
1-1/4 • 7	SAE Grade 1 ASTM A307	375.0 (508.43)	450.0 (610.11)	500.0 (677.91)	550.0 (745.70)	700.0 (949.07)	650.0 (881.28)	500.0 (677.91)
	SAE Grade 2	375.0 (508.43)	450.0 (610.11)	500.0 (677.91)	550.0 (745.70)	700.0 (949.07)	650.0 (881.28)	500.0 (677.91)
	SAE Grade 4	738.3 (1001.00)	885.9 (1201.12)	984.4 (1334.67)	1082.8 (1468.08)	1378.1 (1868.45)	1279.7 (1735.04)	984.4 (1334.67)
	SAE Grade 5 ASTM A449	840.2 (1139.16)	1008.3 (1367.07)	1120.3 (1518.93)	1232.3 (1670.78)	1568.4 (2126.47)	1456.4 (1974.62)	1120.3 (1518.93)
	SAE Grade 7	1191.8 (1615.87)	1430.2 (1939.09)	1589.1 (2154.53)	1748.0 (2369.97)	2224.7 (3016.30)	2065.8 (2800.85)	1589.1 (2154.53)
	SAE Grade 8 ASTM A354 Grade BD	1362.9 (1847.85)	1635.5 (2217.44)	1817.2 (2463.80)	1998.9 (2710.15)	2544.1 (3449.34)	2362.3 (3202.85)	1817.2 (2463.80)
	ASTM A354 Grade BC	1192.4 (1616.68)	1430.9 (1940.04)	1589.8 (2155.48)	1748.8 (2371.05)	2225.8 (3017.78)	2066.8 (2802.20)	1589.8 (2155.48)

All values in foot pounds and (Newton meters)

Nominal bolt size	Grade Designation and Standard	Zinc or Cadmium Plated	If instructions call for :					
			Loctite 222 or 262	Loctite 242	Loctite 271	Loctite 272	Loctite 277	Bare
1-1/4 • 12	SAE Grade 1 ASTM A307	414.8 (562.40)	497.8 (674.93)	553.1 (749.90)	608.4 (824.88)	774.4 (1049.95)	719.1 (974.97)	553.1 (749.90)
	SAE Grade 2	414.8 (562.40)	497.8 (674.93)	553.1 (749.90)	608.4 (824.88)	774.4 (1049.95)	719.1 (974.97)	553.1 (749.90)
	SAE Grade 4	816.8 (1107.43)	980.2 (1328.97)	1089.1 (1476.62)	1198.0 (1624.27)	1524.7 (2067.22)	1415.8 (1919.57)	1089.1 (1476.62)
	SAE Grade 5 ASTM A449	930.5 (1261.60)	1116.6 (1513.90)	1240.6 (1682.03)	1364.7 (1850.29)	1736.9 (2354.92)	1612.8 (2186.66)	1240.6 (1682.03)
	SAE Grade 7	1320.7 (1790.63)	1584.8 (2148.70)	1760.9 (2387.46)	1937.0 (2626.22)	2465.3 (3342.50)	2289.2 (3103.74)	1760.9 (2387.46)
	SAE Grade 8 ASTM A354 Grade BD	1509.4 (2046.47)	1811.3 (2455.80)	2012.5 (2728.59)	2213.8 (3001.51)	2817.5 (3820.02)	2616.3 (3547.23)	2012.5 (2728.58)
	ASTM A354 Grade BC	—	—	—	—	—	—	—

All values in foot pounds and (Newton meters)

Nominal bolt size	Grade Designation and Standard	Zinc or Cadmium Plated	If instructions call for :					
			Loctite 222 or 262	Loctite 242	Loctite 271	Loctite 272	Loctite 277	Bare
1-3/8 • 6	SAE Grade 1 ASTM A307	491.1 (665.84)	589.4 (799.12)	654.8 (887.79)	720.3 (976.60)	916.8 (1243.00)	851.3 (1154.21)	654.8 (887.80)
	SAE Grade 2	491.1 (665.84)	589.4 (799.12)	654.8 (887.79)	720.3 (976.60)	916.8 (1243.00)	851.3 (1154.21)	654.8 (887.80)
	SAE Grade 4	968.1 (1312.57)	1161.7 (1575.06)	1290.8 (1750.10)	1419.9 (1925.13)	1807.1 (2450.10)	1678.0 (2275.07)	1290.8 (1750.09)
	SAE Grade 5 ASTM A449	1102.1 (1494.25)	1322.6 (1793.20)	1469.5 (1992.38)	1616.5 (2191.68)	2057.3 (2789.33)	1910.4 (2590.16)	1469.5 (1992.38)
	SAE Grade 7	1563.6 (2119.96)	1876.4 (2544.06)	2084.8 (2826.61)	2293.3 (3109.30)	2918.8 (3957.37)	2710.3 (3674.68)	2084.8 (2826.61)
	SAE Grade 8 ASTM A354 Grade BD	1786.6 (2422.30)	2144.0 (2906.88)	2382.2 (3229.83)	2620.4 (3552.79)	3335.1 (4521.80)	3096.8 (4198.70)	2382.2 (3229.83)
	ASTM A354 Grade BC	1563.6 (2119.96)	1876.4 (2544.06)	2084.8 (2826.61)	2293.3 (3109.30)	2918.8 (3957.37)	2710.3 (3674.68)	2084.8 (2826.61)

All values in foot pounds and (Newton meters)

Nominal bolt size	Grade Designation and Standard	Zinc or Cadmium Plated	If instructions call for :					
			Loctite 222 or 262	Loctite 242	Loctite 271	Loctite 272	Loctite 277	Bare
1-3/8 • 12	SAE Grade 1 ASTM A307	559.5 (758.58)	671.3 (910.16)	745.9 (1011.30)	820.5 (1112.45)	1044.3 (1415.88)	969.7 (1314.74)	745.9 (1011.30)
	SAE Grade 2	559.5 (758.58)	671.3 (910.16)	745.9 (1011.30)	820.5 (1112.45)	1044.3 (1415.88)	969.7 (1314.74)	745.9 (1011.30)
	SAE Grade 4	1102.1 (1494.25)	1322.6 (1793.21)	1469.5 (1992.38)	1616.5 (2191.68)	2057.3 (2789.33)	1910.4 (2590.16)	1469.5 (1992.38)
	SAE Grade 5 ASTM A449	1254.3 (1700.60)	1505.1 (2040.64)	1672.3 (2267.34)	1839.6 (2494.16)	2341.3 (3174.38)	2174.0 (2947.55)	1672.3 (2267.34)
	SAE Grade 7	1780.2 (2413.63)	2136.2 (2896.30)	2373.6 (3218.17)	2611.0 (3540.04)	3323.0 (4505.39)	3085.7 (4183.65)	2373.6 (3218.17)
	SAE Grade 8 ASTM A354 Grade BD	2034.1 (2757.87)	2441.0 (3309.56)	2712.2 (3677.25)	2983.4 (4044.95)	3797.1 (5148.18)	3525.8 (4780.35)	2712.2 (3677.25)
	ASTM A354 Grade BC	—	—	—	—	—	—	—

All values in foot pounds and (Newton meters)

Nominal bolt size	Grade Designation and Standard	Zinc or Cadmium Plated	If instructions call for :					
			Loctite 222 or 262	Loctite 242	Loctite 271	Loctite 272	Loctite 277	Bare
1-1/2 • 6	SAE Grade 1 ASTM A307	652.5 (884.67)	783.0 (1061.60)	870.0 (1179.56)	957.0 (1297.52)	1218.0 (1651.39)	1131.0 (1533.43)	870.0 (1179.56)
	SAE Grade 2	652.5 (884.67)	783.0 (1061.60)	870.0 (1179.56)	957.0 (1297.52)	1218.0 (1651.39)	1131.0 (1533.43)	870.0 (1179.56)
	SAE Grade 4	1283.9 (1740.74)	1540.7 (2088.91)	1711.9 (2321.03)	1883.1 (2553.14)	2396.6 (3249.36)	2225.4 (3017.24)	1711.9 (2321.03)
	SAE Grade 5 ASTM A449	1462.5 (1982.88)	1755.0 (2379.46)	1950.0 (2643.85)	2145.0 (2908.23)	2730.0 (3701.39)	2535.0 (3437.00)	1950.0 (2643.85)
	SAE Grade 7	2074.2 (2812.24)	2489.1 (3374.77)	2765.6 (3749.66)	3042.2 (4124.67)	3871.9 (5249.60)	3595.3 (4874.58)	2765.6 (3749.66)
	SAE Grade 8 ASTM A354 Grade BD	2370.9 (3214.51)	2845.1 (3857.44)	3161.3 (4286.15)	3477.4 (4714.73)	4425.8 (6000.58)	4109.6 (5571.88)	3161.3 (4286.15)
	ASTM A354 Grade BC	2074.9 (2813.20)	2489.9 (3375.85)	2766.6 (3751.01)	3043.2 (4126.03)	3873.2 (5251.36)	3596.5 (4876.20)	2766.6 (3751.01)

All values in foot pounds and (Newton meters)

Nominal bolt size	Grade Designation and Standard	Zinc or Cadmium Plated	If instructions call for :					
			Loctite 222 or 262	Loctite 242	Loctite 271	Loctite 272	Loctite 277	Bare
1-1/2 • 12	SAE Grade 1 ASTM A307	734.1 (995.30)	880.9 (1194.34)	978.8 (1327.07)	1076.6 (1459.67)	1370.3 (1857.88)	1272.4 (1725.14)	978.8 (1327.07)
	SAE Grade 2	734.1 (995.30)	880.9 (1194.34)	978.8 (1327.07)	1076.6 (1459.67)	1370.3 (1857.88)	1272.4 (1725.14)	978.8 (1327.07)
	SAE Grade 4	1445.6 (1959.97)	1734.8 (2352.07)	1927.5 (2613.34)	2120.3 (2874.33)	2698.5 (3658.68)	2505.8 (3397.41)	1927.5 (2613.34)
	SAE Grade 5 ASTM A449	1645.3 (2230.73)	1974.4 (2676.93)	2193.8 (2974.40)	2413.1 (3271.73)	3071.3 (4164.13)	2851.9 (3866.66)	2193.8 (2974.40)
	SAE Grade 7	2334.4 (3165.02)	2801.3 (3798.06)	3112.5 (4219.99)	3423.8 (4642.05)	4357.5 (5907.98)	4046.3 (5486.05)	3112.5 (4219.99)
	SAE Grade 8 ASTM A354 Grade BD	2667.7 (3616.92)	3201.2 (4340.25)	3556.9 (4822.51)	3912.6 (5304.78)	4979.6 (6751.44)	4623.9 (6269.17)	3556.9 (4822.51)
	ASTM A354 Grade BC	—	—	—	—	—	—	—

Other Fastener Torque Specifications

All values in foot-pounds and (Newton-meters)

Nominal bolt size	18 - 8 Stainless Steel	316 Stainless Steel	Brass	Aluminum 2024 - T4
1/4 - 20	6.3 (8.54)	6.6 (8.95)	5.1 (6.91)	3.8 (5.15)
1/4 - 28	7.8 (10.57)	8.3 (11.25)	6.4 (8.67)	4.8 (6.50)
5/16 - 18	11.0 (14.90)	11.5 (15.60)	8.9 (12.06)	6.7 (9.08)
5/16 - 24	11.8 (16.00)	12.3 (16.67)	9.7 (13.15)	7.2 (9.76)
3/8 - 16	19.7 (26.71)	20.6 (27.93)	16.0 (21.70)	11.9 (16.13)
3/8 - 24	21.6 (29.28)	22.6 (30.64)	17.7 (24.00)	13.1 (17.76)
7/16 - 14	31.3 (42.44)	32.8 (44.47)	26.4 (35.80)	19.0 (25.76)
7/16 - 20	33.3 (45.15)	34.8 (47.18)	27.3 (37.00)	20.2 (27.38)
1/2 - 13	43.1 (58.43)	45.2 (61.28)	35.2 (47.72)	26.1 (35.38)
1/2 - 20	45.1 (61.14)	47.1 (63.86)	36.9 (50.00)	27.3 (37.00)
9/16 - 12	56.8 (77.00)	59.4 (80.53)	46.5 (63.04)	34.4 (46.64)
9/16 - 18	62.7 (85.00)	65.6 (88.94)	51.3 (69.55)	38.0 (51.52)
5/8 - 11	92.5 (125.41)	96.7 (131.10)	75.6 (102.50)	59.6 (80.80)
5/8 - 18	103.7 (140.60)	108.4 (146.97)	84.7 (114.84)	66.5 (90.16)
3/4 - 10	127.5 (172.86)	131.8 (178.70)	104.1 (141.14)	81.7 (110.77)
3/4 - 16	124.2 (168.39)	129.8 (175.98)	101.7 (137.88)	79.8 (108.19)

Other Fastener Torque Specifications

All values in foot-pounds and (Newton-meters)

Nominal bolt size	18 - 8 Stainless Steel	316 Stainless Steel	Brass	Aluminum 2024 - T4
7/8 - 9	194.0 (263.03)	202.5 (274.55)	158.8 (215.30)	124.6 (168.93)
7/8 - 14	193.2 (261.94)	201.7 (273.47)	157.9 (214.08)	124.2 (168.40)
1 - 8	286.7 (388.71)	299.6 (406.20)	234.6 (318.07)	183.8 (249.20)
1 - 14	259.2 (351.43)	270.8 (367.16)	212.1 (287.57)	166.3 (225.47)
1-1/8 • 7	413.0 (559.95)	432.0 (585.71)	337.0 (456.91)	265.0 (359.29)
1-1/8 • 12	390.0 (528.77)	408.0 (553.17)	318.0 (431.15)	251.0 (340.31)
1-1/4 • 7	523.0 (709.09)	546.0 (740.28)	428.0 (580.30)	336.0 (455.55)
1-1/4 • 12	480.0 (650.80)	504.0 (683.33)	394.0 (534.19)	308.0 (417.60)
1-1/2 • 6	888.0 (1203.97)	930.0 (1260.91)	727.0 (985.68)	570.0 (772.82)
1-1/2 • 12	703.0 (953.14)	732.0 (992.46)	575.0 (779.60)	450.0 (610.12)

BALDOR MOTOR MAINTENANCE

MSSM0274AE/9731AV

Most of the information in this document is taken from the *Baldor Electric Company Instruction, Operation, and Maintenance Manual*, and provides a means of more accurately determining motor lubrication requirements based on local conditions.

General Maintenance

Inspect, clean, and test motors at regular intervals— approximately every 500 operating hours or every three months, whichever comes first. Lubricate motors at the intervals determined herein. Keep accurate maintenance records.

DANGER: Electrocuting and Electrical Burn Hazards



Contact with high voltage will electrocute or burn you. Power switches on the machine and the control box do not eliminate these hazards. High voltage is present at the machine unless the main power is off. Electrical power can cause death or severe injury.

- ☞ Do not service machine unless qualified and authorized.
- ☞ Lock OFF and tag out power at the wall disconnect before servicing, or in accordance with factory service procedures.

DANGER: Entangle and Crush Hazard



Contact with moving components normally isolated by guards, covers, and panels, can entangle and crush your limbs. These components move automatically.

- ☞ Do not service machine unless qualified and authorized.
- ☞ Lock OFF and tag out power at the wall disconnect before servicing, or in accordance with factory service procedures.

Clean—Keep the exterior of the motor free of dirt, oil, grease, water, etc. Keep ventilation openings clear. Oily vapor, paper pulp, textile lint, etc., can accumulate and block ventilation, causing overheating and early motor failure.

Test—Periodically, check the motor and winding insulation integrity using a “megger.” Record the megger readings and immediately investigate any significant drop in insulation resistance. Check all electrical connectors to be sure they are tight.

Lubricate—Determine the proper lubrication interval for your motor as explained in “How to Determine Lubrication Interval” in this section, and lubricate accordingly.

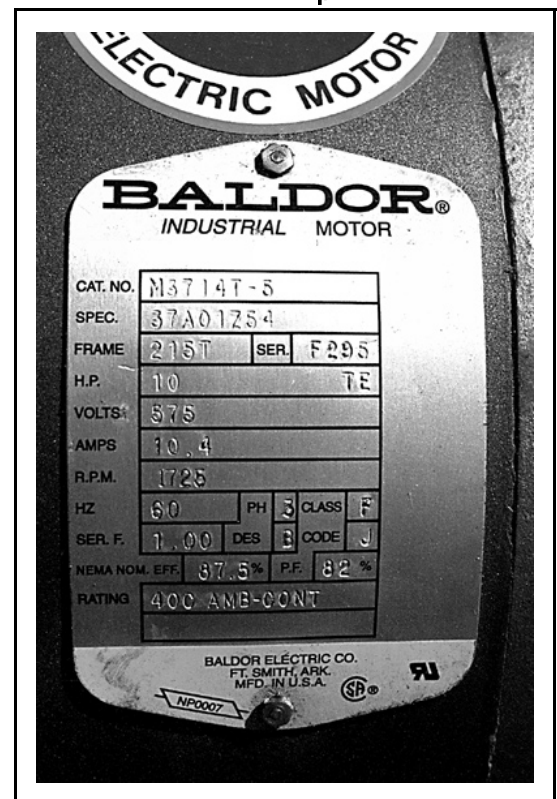

FIGURE 1 (MSSM0274AE)
Typical Motor Data Plate

How to Determine Lubrication Interval—The useful life of antifriction bearing grease can be estimated, based on service conditions, frame type, and motor rpm. An example of determining the correct lubrication interval is provided below.

Ex: A fan motor, operating at an ambient temperature of 109°F (43°C) in a moderately corrosive atmosphere. The motor has a NEMA 286T/(IEC 180) frame and is rated at 1750 rpm.

1. Table 1 classifies the service condition as “severe.”
2. Table 2 specifies a 0.5 service condition multiplier value for “severe” service condition.
3. Table 3 specifies 9500 hours as the recommended lubrication interval for frame sizes 254 to 286 (see nameplate), given standard service conditions.
4. Multiply .5 (*service condition multiplier value*) by 9500 hours (*recommended lubrication interval*) = 4750 hours (*calculated lubrication interval*).
5. Table 4 shows that the amount of grease to be added is 0.32 ounces (9.1 grams).

Table 1 — Determining the Service Condition

Severity of Service	Maximum Ambient Temperature	Atmospheric Contamination	Type of Bearing
Standard	104°F (40°C)	Clean, little corrosion	Deep groove ball bearing
Severe	122°F (50°C)	Moderate dirt, corrosion	Ball thrust, Roller
Extreme	>122°F (>50°C) or Class H Insulation (Note 1)	Severe dirt, abrasive dust, corrosion	All bearings
Low Temperature	-22°F (-30°C) (Note 2)		

Note 1: Special high temperature grease is recommended.

Note 2: Special low temperature grease is recommended.

Table 2 — Service Condition Multiplier Value

Operating Condition	Multiplier
Standard	1.0
Severe	0.5
Extreme	0.1

Table 3 — Recommended Lubrication Intervals at Standard Service Conditions

NEMA (IEC) Frame Size	Rated Speed - RPM			
	3600	1800	1200	900
Up to 215 (132)	5500 Hrs.	12000 Hrs.	18000 Hrs.	22000 Hrs.
254 to 286 (160 - 180)	3600 Hrs.	9500 Hrs.	15000 Hrs.	18000 Hrs.
324 to 365 (200 - 225)	2200 Hrs.(Note 3)	7400 Hrs.	12000 Hrs.	15000 Hrs.
404 to 5000 (280 - 315)	2200 Hrs.(Note 3)	3500 Hrs.	7400 Hrs.	10500 Hrs.

Note 3: Bearings in 404 through 5000 frame, 2 pole motors are either 6313 or 6314 bearings and the lubrication interval is shown in the table. **If roller bearings are used, the bearings must be lubricated more frequently. Divide the listed lubrication interval by two.**

Table 4 — Lubrication Amounts per Frame

NEMA (IEC) Frame Size	Bearing Description					
	These are the “Large” bearings (Shaft End) in each frame size (Note 4)					
	Largest bearing in size category	OD D mm	Width B mm	Grease gun strokes (Note 5)	Volume of grease to be added	
ounces					grams	
Up to 215 (132)	6307	80	21	2.5	0.16	4.7
254 to 286 (160 - 180)	6311	120	29	5.0	0.32	9.1
324 to 365 (200 - 225)	6313	140	33	7.0	0.43	12.2
404 to 5000 (280 - 315)	NU322	240	50	18.0	1.11	31.5

Note 4: Smaller bearings in size category may require reduced amounts of grease.

Note 5: See “Correct Grease Gun Procedures” for information on estimating the output of hand-operated grease guns.

Lubrication Recommendations

Type of Grease—Use Shell Dolium R (factory installed) or Chevron SRI greases for standard service conditions. The extreme and low temperature conditions are not normally encountered in the laundry. However, for extreme conditions, use Darmex 707 and for low temperature conditions, use Arrowsell 7. Contact Baldor for equivalents, if necessary.

Correct Grease Gun Procedures

1. Use hand-operated grease gun, not a pneumatic grease gun. Pump grease slowly, taking 10 to 12 seconds to complete each stroke.
2. Apply quantity of grease called for. Over-lubrication can be as damaging as under-lubrication. Where quantities are stated in strokes, one stroke of the grease gun is assumed to provide .0624 fluid oz. (1.77 grams) (by volume) of grease. Therefore, one fluid ounce (28.3 grams) of grease would be provided by 16 strokes of the grease gun. Determine the flow rate of your grease gun by pumping one ounce into a calibrated container. If fewer than 16 strokes are required, all quantities in strokes in the chart should be reduced accordingly. If more than 16 strokes are required, the number of strokes should be increased. **Before starting lubrication, make sure your grease gun is working and that you get a full charge of grease with every stroke.**
3. Do not over-lubricate motors. Over-lubrication of a motor can seriously damage it by forcing grease into motor windings. Over-lubrication of the extract motor can force grease into the centrifugal switch causing it to malfunction.
4. Do not allow grease to drip on the brake disk or clutch tire/drum during lubrication. This will reduce the braking action considerably, and may permit the cylinder to creep while loading and unloading.

Lubrication Procedure

	NOTICE: Motor Damage
---	-----------------------------

To avoid damage to motor bearings, grease must be kept free of dirt. For an extremely dirty environment, contact your Baldor distributor or an authorized Baldor Service Center for additional information.

1. Clean grease fittings.
2. Remove grease outlet plug.
3. Add recommended amount of grease. Be sure grease to be added is compatible with the grease already in motor. Consult your Baldor distributor or an authorized Baldor Service Center if grease other than recommended is to be used. Stop when new grease appears at shaft hole in the endplate or grease outlet plug.
4. Replace grease outlet plug.

Section
Drive Assemblies

2

Drive Chart 3010& 3015 G5E, G5X



Pellerin Milnor Corporation
P. O. Box 400, Kenner, LA 70063-0400

BMP040004/2004055V
(Sheet 1 of 1)

Litho in U.S.A.

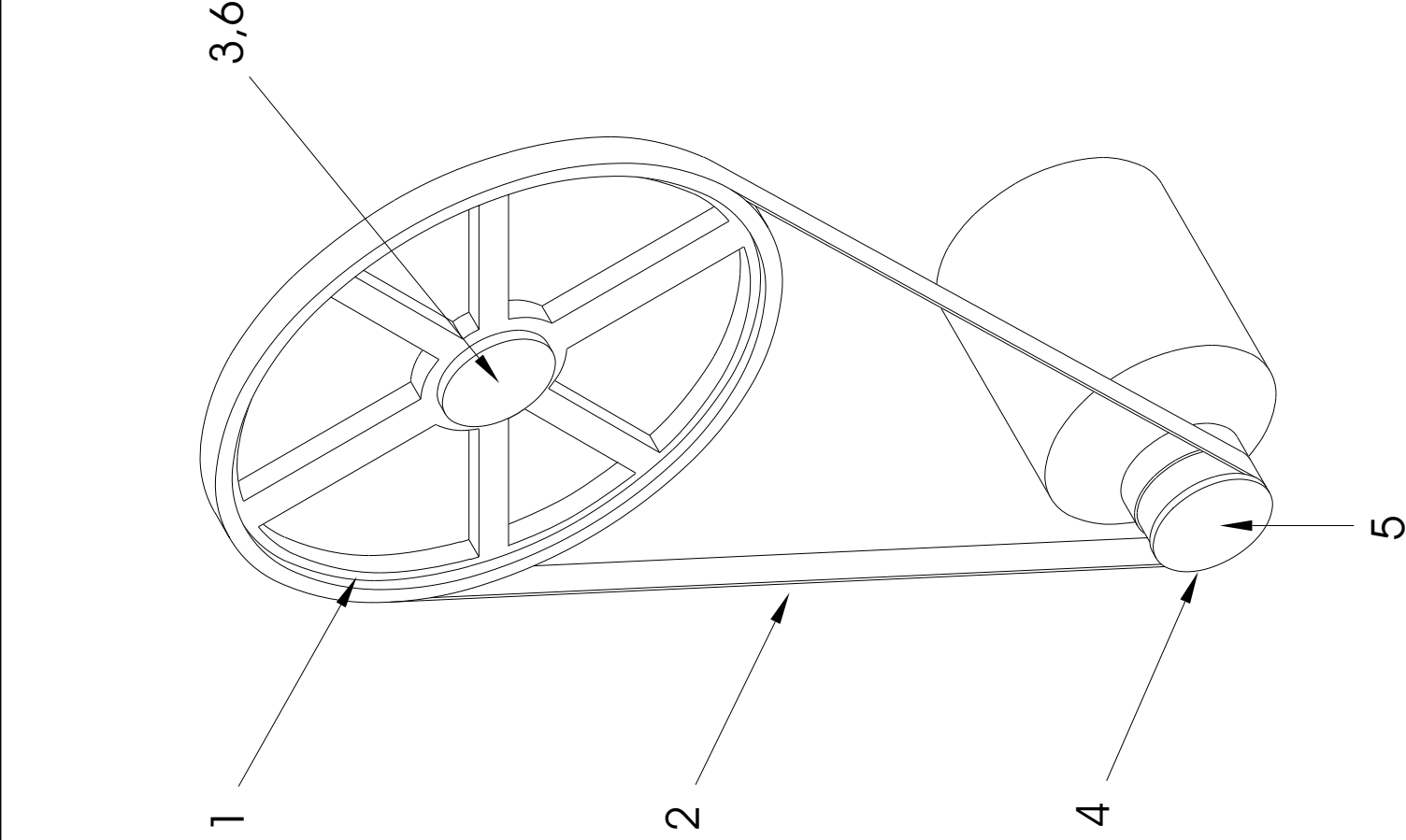

Parts List—Drive Chart

Find the correct assembly first, then find the needed components. The item letters (A, B, C, etc.) assigned to assemblies are referred to in the "Used In" column to identify which components belong to an assembly. The item numbers (1, 2, 3, etc.) assigned to components relate the parts list to the illustration.

Used In	Item	Part Number	Description	Comments
			ASSEMBLIES	
			none	
			COMPONENTS	
all	1	5613V19	PULLEY 19" 1GR 3V	
all	2	56VR0800M2	VBELT 3V800 MATCHSET2 EA=1BLT	
all	3	56Q1KSK	1+1/2" BUSH VPUL QD TYPE SK	
all	4	560260R3JA	VPUL 3G3V2.60 QD TYPE JA	
all	5	56Q0RJA	7/8" BUSHING VPUL QD TYPE "JA"	
all	6	15E230	STRMACHKEY 3/8SQX2+1/2 TOL.+0	

Motor Mount
3010 & 3015 G5E, G5X, CGE



Pellerin Milnor Corporation
P. O. Box 400, Kenner, LA 70063-0400

BMP040005/2004055V
(Sheet 1 of 2)

Litho in U.S.A.

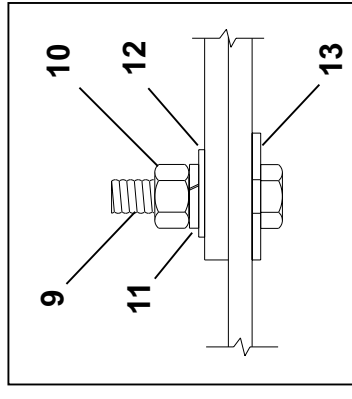
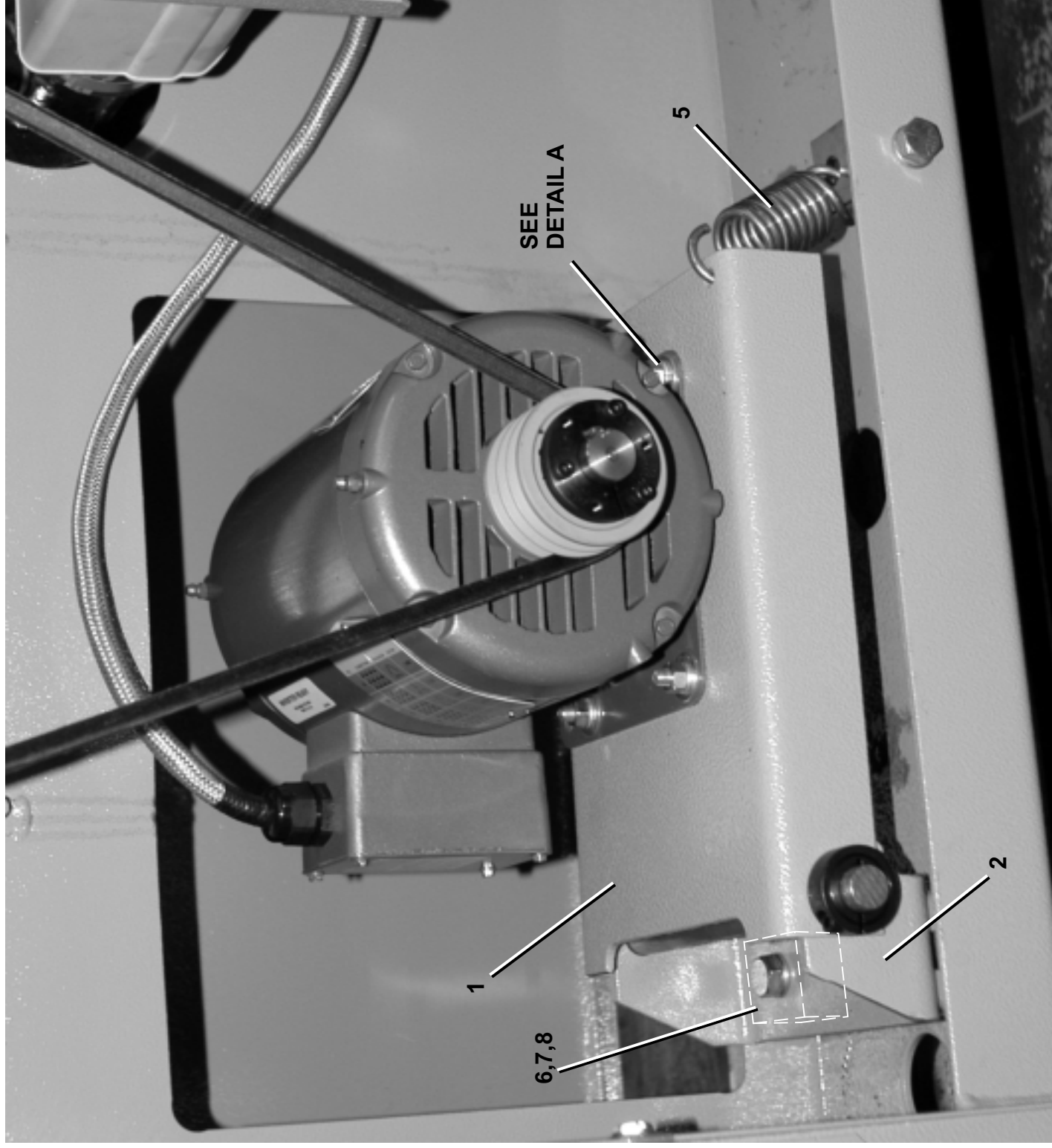

DETAIL A
(4 PLACES)

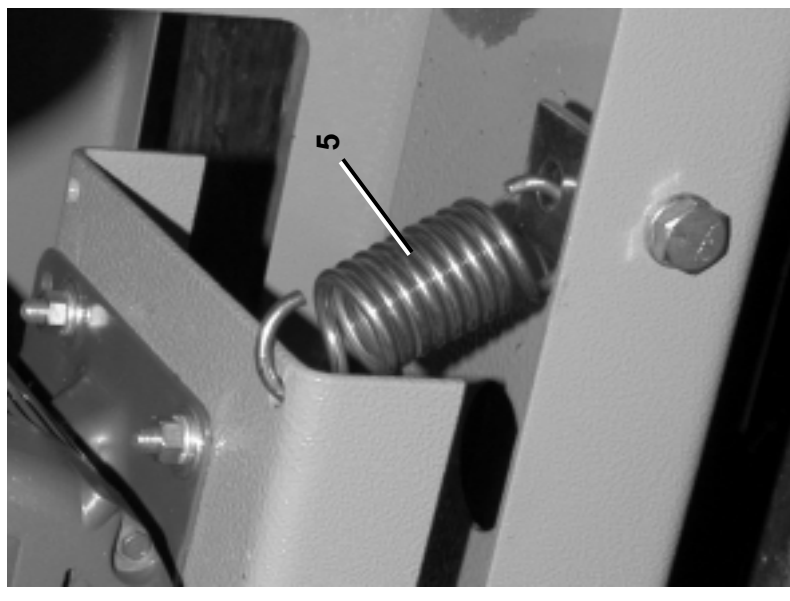
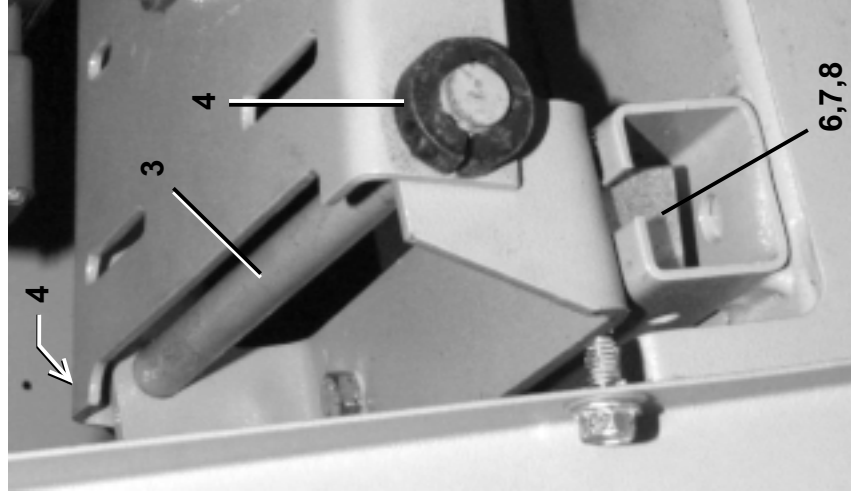



Pellerin Milnor Corporation
P. O. Box 400, Kenner, LA 70063-0400

Litho in U.S.A.

Parts List—Motor Mount

Find the correct assembly first, then find the needed components. The item letters (A, B, C, etc.) assigned to assemblies are referred to in the "Used In" column to identify which components belong to an assembly. The item numbers (1, 2, 3, etc.) assigned to components relate the parts list to the illustration.

Used In	Item	Part Number	Description	Comments
-----ASSEMBLIES-----				
	A	GDB30003	3010C4 DRIVE BASE INSTALL	
	B	ADB30003	3010C4 DRVIE BASE ASSY	
-----COMPONENTS-----				
all	1	02 04256B	PLATE=MOTOR MOUNT, 3010	
all	2	02 04257C	BRKT=MOTOR MOUNT, 3010	
all	3	02 04258	SHAFT=MOTOR MOUNT, 3022S4	
all	4	54JH10750C	SHFTCOLLAR 3/4" CLPTYP CFG#12S	
all	5	02 04259	SPRNG/MOT MOUNT/3022S4#SPC2690	
all	6	02 19283	NUT=1/2-13UNCX1+1/2SQ SPEC	
all	7	15G198	HXFLGNUT 3/8-16 ZINC	
all	8	15K092Z	HEXFLGSCR 3/8-16X1 GR5 ZINC	
all	9	15K065	HEXCAPSCR 5/16-18UNC2AX1 GR5 Z	
all	10	15G185	HXNUT 5/16-18UNC2B SAE ZINC GR	
all	11	15U210	LOKWASHER MEDIUM 5/16 ZINCPL	
all	12	15U200	FLATWASHER(USS STD) 5/16"ZNC P	
all	13	15U241	FLATWASHER 13/32IDX1+3/4ODX14G	

Clutch Brake

3010, 3015CGE ; 30015, 30022C4E

BMP020054/2004103V
(Sheet 1 of 1)



Pellerin Milnor Corporation
P. O. Box 400, Kenner, LA 70063-0400

Litho in U.S.A.

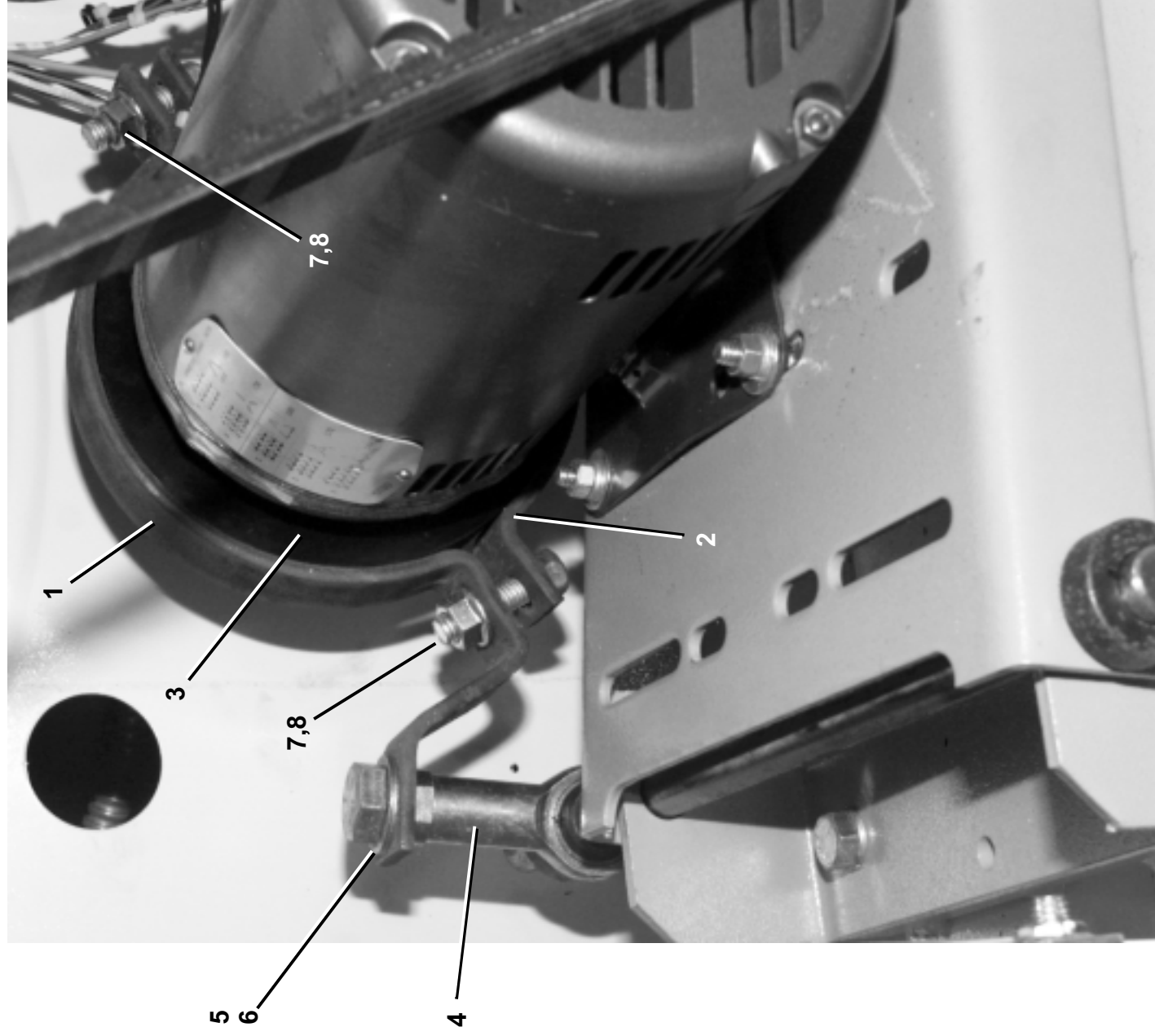

Parts List—Clutch Brake

Find the correct assembly first, then find the needed components. The item letters (A, B, C, etc.) assigned to assemblies are referred to in the "Used In" column to identify which components belong to an assembly. The item numbers (1, 2, 3, etc.) assigned to components relate the parts list to the illustration.

Used In	Item	Part Number	Description	Comments
			-----ASSEMBLIES-----	
A		GBR30001	3022C4E BRAKE INSTALL	
			-----COMPONENTS-----	
	1	04 20257	BRAKE SHOE-TOP -SHUTTLE	
all				
	2	04 20369A	BRAKE SHOE-BOTTOM 30XX COIN	
all				
	3	54AA00PFRE	FEM ROD END ALIN#VF-12G 3/4"	
all				
	4	54H164A	CLUTCH 12VDC MAPM02	
all				
	5	15K230	HXCPC-3/4-16X1+3/4 GR8 ZINC	
all				
	6	15U321H	FLTWASH 3/4 HARD ASTM F436	
all				
	7	15K154H	INDHEXFLGSCR 1/2-13X1+3/4GR8ZN	
all				
	8	15G225H	HEXFLGNUT 1/2-13 SERRATED 18-8	

Section
Bearing Assemblies

3

Shell & Cylinder Installation

3010 & 3015 G5E, G5X, CGE

BMP040007/2004055V
(Sheet 1 of 2)



Pellerin Milnor Corporation
P. O. Box 400, Kenner, LA 70063-0400

Litho in U.S.A.

BEARING
INSTALLATION
SEE BMP030006

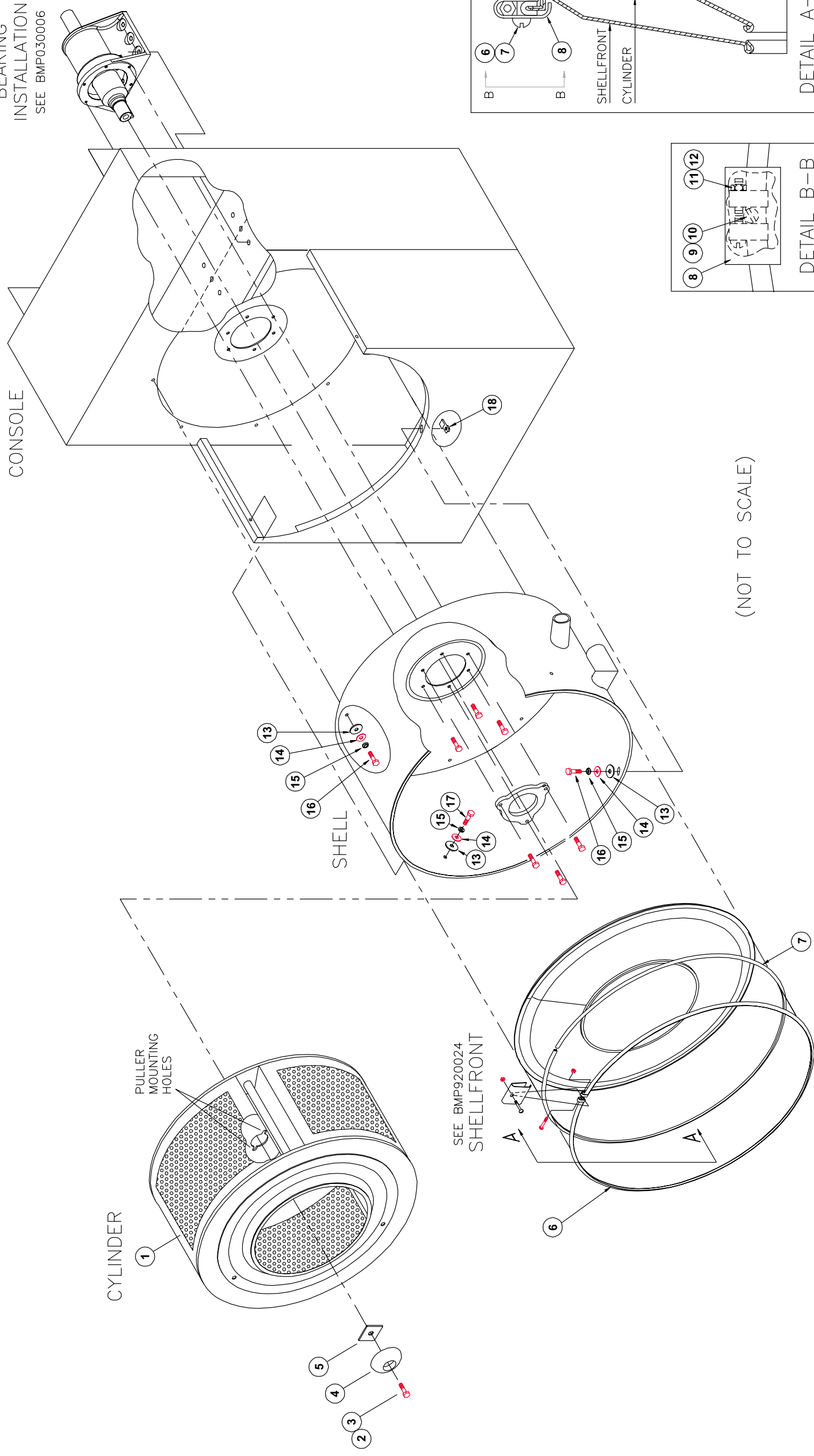

CONSOLE

SHELL

CYLINDER

PULLER
MOUNTING
HOLES

SEE BMP920024
SHELLFRONT

(NOT TO SCALE)

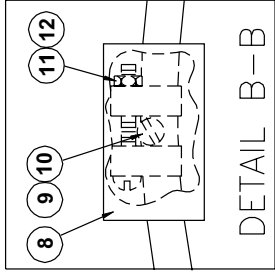
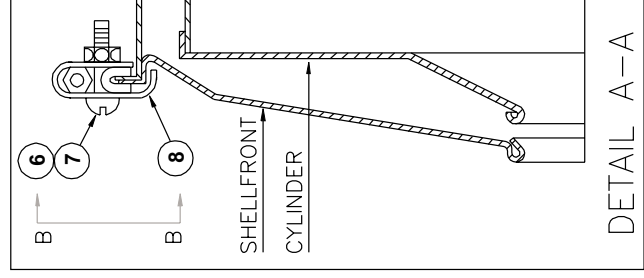



Pellerin Milnor Corporation
P. O. Box 400, Kenner, LA 70063-0400

Litho in U.S.A.

Parts List—Shell & Cylinder Installation

Find the correct assembly first, then find the needed components. The item letters (A, B, C, etc.) assigned to assemblies are referred to in the "Used In" column to identify which components belong to an assembly. The item numbers (1, 2, 3, etc.) assigned to components relate the parts list to the illustration.

Used In	Item	Part Number	Description	Comments
-----ASSEMBLIES-----				
	A	GCA30003	3010T5 CYLINDER INSTALL	3010G5E,G5X,CGE
	B	GCA30002	3015 CYLINDER INSTALL	3015G5E,G5X,CGE
	C	G33 04000U	CONDUIT+SHELLFT 3015V/T NO P.B	
	D	GSF30001	3015C4E SHELLFRONT INSTALL	
-----COMPONENTS-----				
A	1	ACA3010CYL	CYLINDER ASSY SEAMED 3010	
B	1	ACA3015CYL	CYLINDER ASSY SEAMED 3015	
all	2	15B200	HEXCAPSCR 3/4-10X1+3/4 SS18-8	
all	3	15U350	LOCKWASHER 3/4 MED SS18-8	
all	4	02 11196	COVER=SHAFT RETAINER=304S/S	
all	5	02 14359A	SHAFT RETNR SPACER 2+3/4" SQ	
all	6	Y2 02059	*SHELL CLAMP RING=30" MACHINE	
all	7	02 02087C	EXTRUS*ION-SHELL=30"MACHINES (
all	8	02 02181	GUARD=SHELL MOUNT RING CLIP	
all	9	15K046S	HEXCAPSCR 1/4-20UNC2A X 2.25 S	
all	10	15G168	SQNUT 1/4-20UNC2 SS18-8	
all	11	15N146	RDMACHSCR 10-24UNC2X1 SS18-8	
all	12	15G130	HEXMACHSCRNUT 10-24UNC2 SS18-8	
all	13	02 02293	DOOR HANDLE NUT GASKET	
all	14	15U245	FLTWASH 3/8 STD COMM 18-8 SS	
all	15	24G030N	ROLLED WASH.379ID NYLTITE 37W	
all	16	15K096	HEXCAPSCR 3/8-16UNC2X1SS18-8	
all	17	15K086	HXCAPSCR 3/8-16NCX3/4 SS18-8	
all	18	17N071	NUT J-TYP #C33896-3816-3B 3/8"	

Bearing Assembly and Installation 3010 & 3015 G5E,G5X,CGE

BMP040006/20004171V
(Sheet 1 of 2)



Pellerin Milnor Corporation
P. O. Box 400, Kenner, LA 70063-0400

Litho in U.S.A.

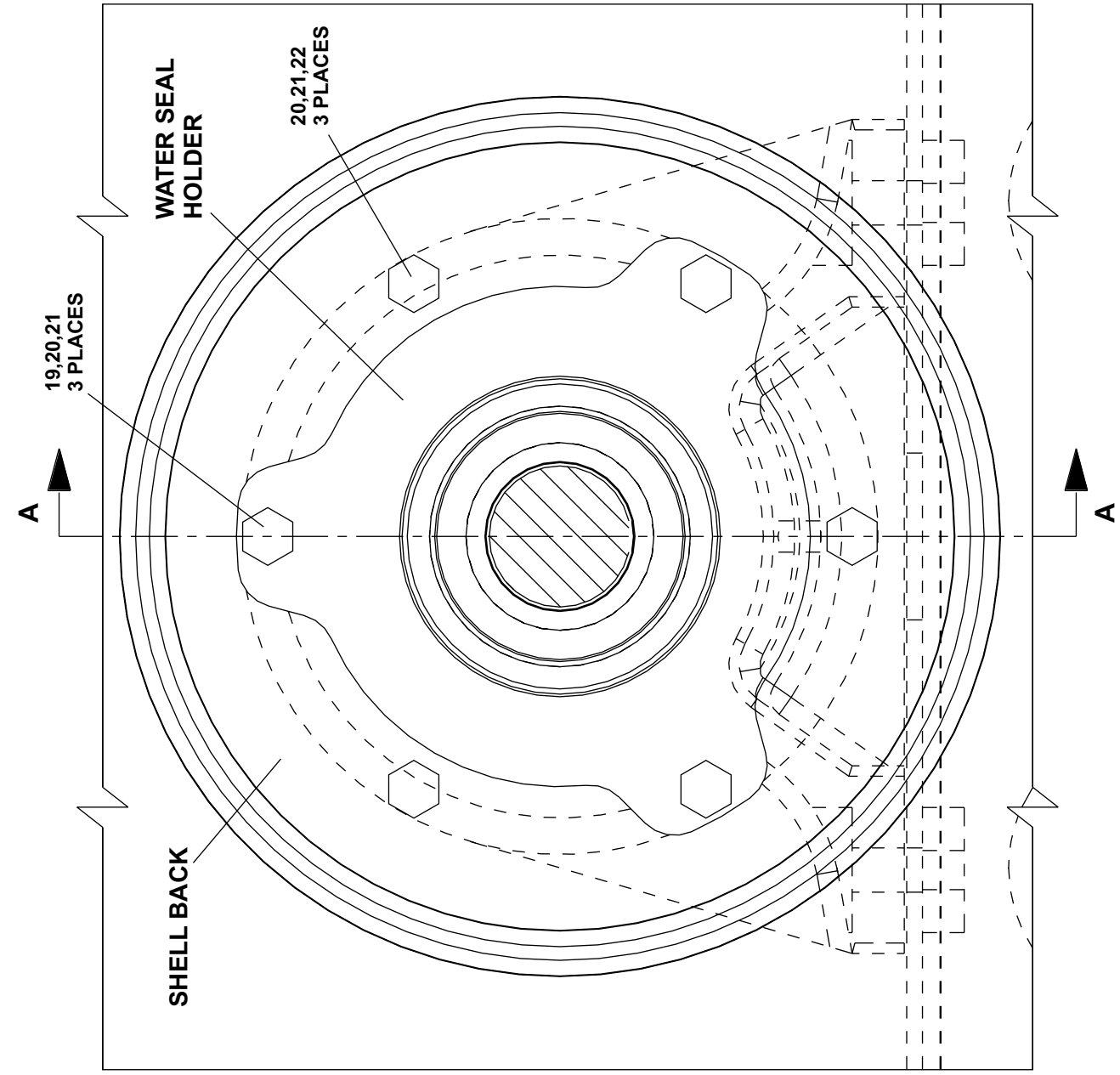

VIEW B-B

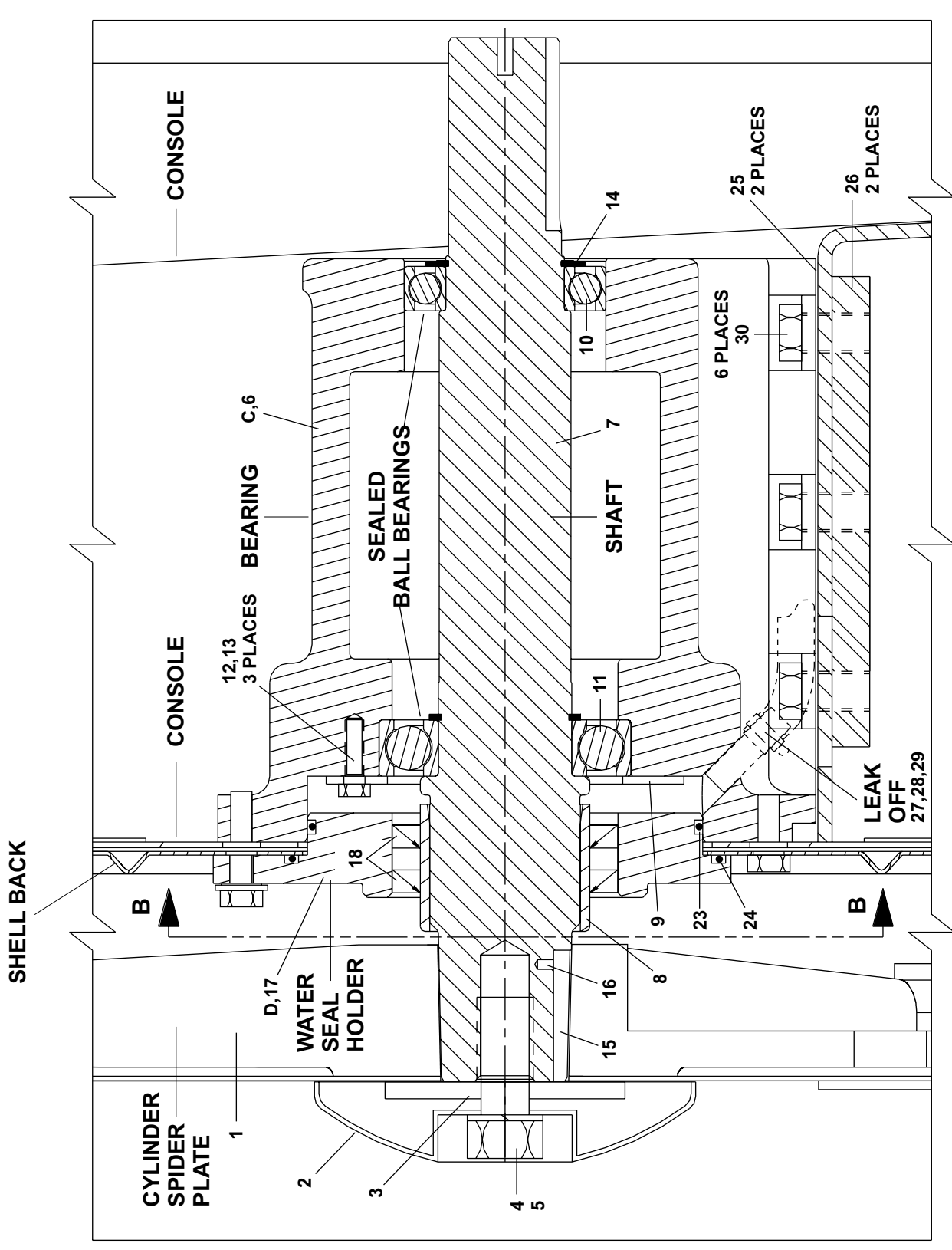

VIEW A-A

Section

4

Shell and Door Assemblies

Shellfront Assembly, Conduit, & Interlock

3010 / 3015 G5E,G5X,CGE

30015 V7J,T5J,C4A,C4E & 30022 V6J,T5J,C4A,C4E

BMP920024/2004055V
(Sheet 1 of 2)



Pellerin Milnor Corporation
P. O. Box 400, Kenner, LA 70063-0400

Litho in U.S.A.

FOR DOOR ASSEMBLY, SEE BMP920009.

FOR INTERLOCK ASSEMBLY, SEE BMP750046.

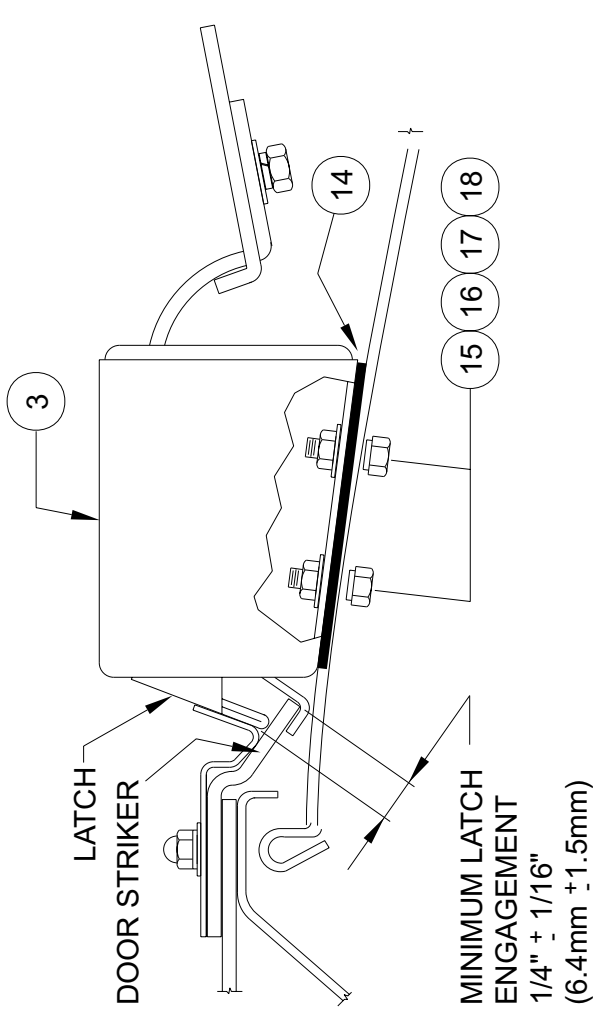
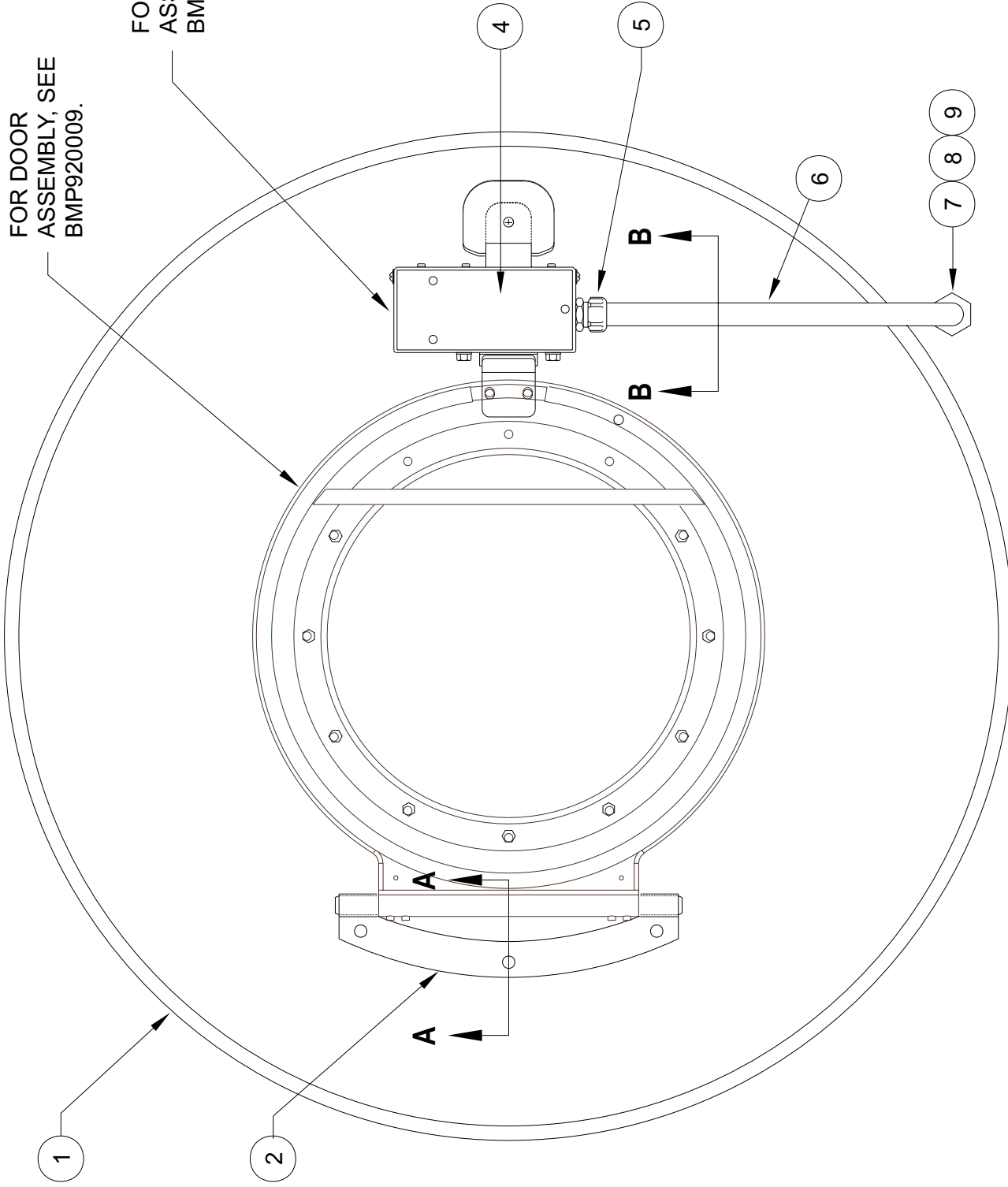

VIEW "B-B"

MINIMUM LATCH ENGAGEMENT
1/4" ± 1/16"
(6.4mm ± 1.5mm)

ADJUSTMENTS:

1. ADJUST DOOR STRIKER SO THAT IT TOUCHES THE LATCH SQUARELY AND EVENLY.
2. ADJUST THE LATCH SO THAT THE MINIMUM ENGAGEMENT WITH THE DOOR FULLY CLOSED EQUALS 1/4" ± 1/16" (6.4mm ± 1.5mm).

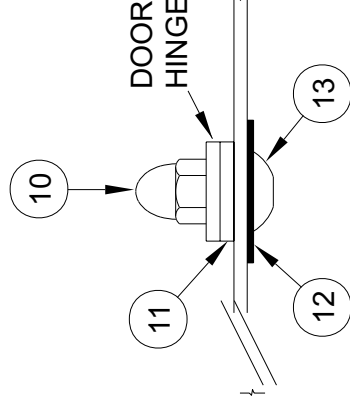

VIEW "A-A"



Pellerin Milnor Corporation
P. O. Box 400, Kenner, LA 70063-0400

Litho in U.S.A.

Used In		Item	Part Number	Description	Comments
<p>Parts List—Shellfront, Conduit & Interlock Find the correct assembly first, then find the needed components. The item letters (A, B, C, etc.) assigned to assemblies are referred to in the "Used In" column to identify which components belong to an assembly. The item numbers (1, 2, 3, etc.) assigned to components relate the parts list to the illustration.</p>					
-----ASSEMBLIES-----					
A		A33 10100C		*SHLASSY (IDNT) UNLOK N4P	3015M4G/J/P, M6J,D4A 3022M5G/J
B		A33 10100H		SHELL FRONT ASSY 3015/20M4A	3015M4A, C4T, M4T, M6A, M6T 3022M5T, 3022C4T
C		A33 10100M		SHLASSY N/LOCK 3015/22S#G/J	3022S4J, S4G, S5J 3015K4A, S4J, S5G, S5J
D		A33 10100N		SHLASSY N/LOCK 3015/22V/T	3010G5E, G5X 3015G5E, G5X, V7J, T5E, T5J, T5X 3022V6J, T5E, T5J, T5X
E		A33 10100F		*SHLASSY (IDNT) UNLOK C4A	3015C4A, 3022C4A
F		A33 10100G		SHLFR TASY N/O ILOK W/PROX	3010CGE, 3015CGE, 30015C4E 30022C4E
-----COMPONENTS-----					
ABCDE	1	X2 02361B		SHELLFRONT, 30" ELECTRIC LOCK	
F	1	X2 02361C		2002296D SHELLFR T=30" ILOC W/PROX	
A,C,D	2	A33 07100C		*DRASSY (INDNT) LK, LOGO N4, 5, 6P	
B	2	A33 07100H		95027 DOOR ASY 3015/3020M4A	
EF	2	A33 07100F		95027# DRASSY (INDNT) LK, LOGO C4A	
A,B	3	EDL00171		INTRLKHSG ASSY=N/UNLOCK 240V	
C	3	EDL00371		INTRLKHSG=N/LOCK+SWITCH240V	
D	3	EDL00271		INTRLKHSG ASSY=N/LOCK 220V	
F	3	EDL00171C		INTRLKHSG ASSY=N/O W/ PROX 240	
all	4	01 10422		NPLATE: DOOR ILOC->N4, 5, 6 P	
all	5	12K040		1/2" COND. EMT COND. PECO #260B	
All	6	03 01446		1/2 EMT CONDUIT 900D=DR INTR	
all	7	10Y71M4GEX		*M4G EXTERNAL CONNECTIONS	
all	8	12K040		1/2" COND. EMT COND. PECO #260B	
all	9	12P1ASSB		SNAPBUSH 7/8" MH X 11/16	
all	10	15G200C		HXCPNUT HI 3/8-16 BRASS NIK PL	
all	11	02 02819C		SPACER-SHELLFRONT/HINGE	
all	12	02 02293		DOOR HANDLE NUT GASKET	
all	13	15K084		TRUSS HXSOK 3/8-16 X 23/32SS	
ABCDE	14	02 03669		GASKET=INTRLK HOUSING	
F	14	02 03669C		GASKET=INTRLK HOUSING 8" LONG	
all	15	15N174		HXCAPSCR 1/4-20UNC2X5/8SS18-8	
all	16	15U180		LOCKWASHER MEDIUM 1/4 ZINCPL	
all	17	24G020N		ROLLED WASH. 252ID NYLTITE 25W	

Used In		Item	Part Number	Description	Comments
All		18	15G168	SQ NUT 1/4-20UNC2 SS18-8	

Door Assembly
3010 / 3015 G5E, G5X, CGE
30015 V7J, T5J, C4A, C4E & 30022 V6J, T5J, C4A, C4E

BMP020002/2004055V
 (Sheet 1 of 2)



Pellerin Milnor Corporation
 P. O. Box 400, Kenner, LA 70063-0400

Litho in U.S.A.

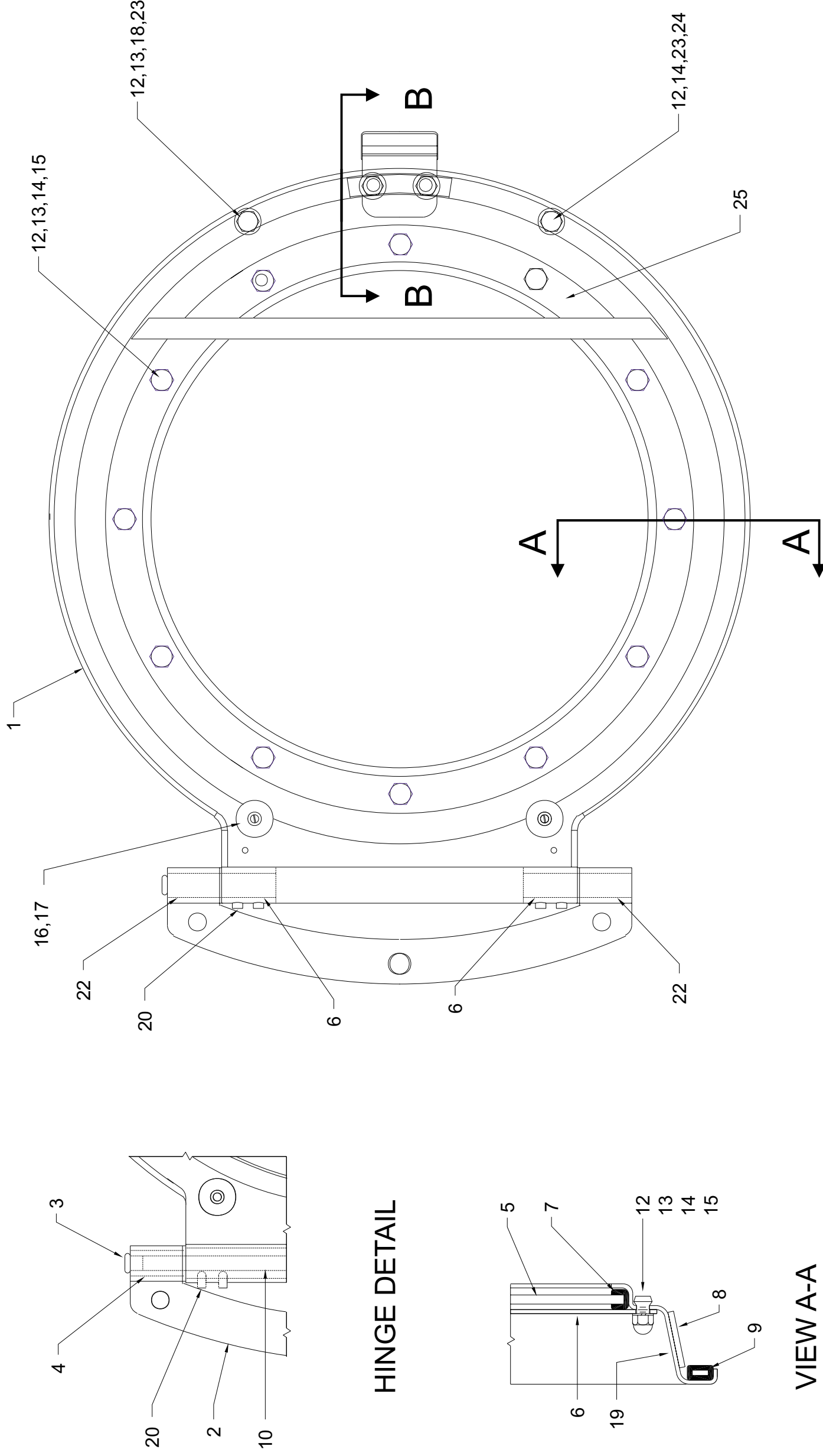

HINGE DETAIL

VIEW A-A

VIEW B-B



Pellerin Milnor Corporation
P. O. Box 400, Kenner, LA 70063-0400

Litho in U.S.A.

Parts List—Door Assembly

Find the correct assembly first, then find the needed components. The item letters (A, B, C, etc.) assigned to assemblies are referred to in the "Used In" column to identify which components belong to an assembly. The item numbers (1, 2, 3, etc.) assigned to components relate the parts list to the illustration.

Used In	Item	Part Number	Description	Comments
-----ASSEMBLIES-----				
	A	A33 07100C	*DRASSY(INDNT)LK,LOGO N4,5,6P	3010/3015 G5E,G5X 3015T5E,T5J,T5X,V7J 3022T5E,T5J,T5X,V6J
	B	A33 07100F	DRASSY (INDNT)LK,LOGO C4A	3010CGE,3015CGE 3015C4T,C4E 3022C4T,C4E
-----COMPONENTS-----				
all	1	X2 02814F	MACH=SHELLDOOR DRAWN, 30XX	
all	2	02 02819	HINGE=STAMPED DOOR 25#	
all	3	12P1AGHP1	HOLEPLUG 3/8"BLACK LPE	
all	4	02 02817	FLANGE BRG=DOOR HINGE-NYLON	
A	5	02 09215	DRGLASS 12 3/8DIA SS STAMPED	
B	5	02 09215D	DR GLASS=N4,5,6P W/MIL LOGO	
all	6	02 09021	RING=DOOR GLASS PRESSURE	
all	7	02 02366	GASKET DOORGLAS GTR52-5220-3	
all	8	02 10545	EXTR BAND-STAMPED SS CYLDOOR	
all	9	02 10342G	GASKET 15" DOOR-BLACK	
all	10	02 02764	HINGEPIN=SHELLDOOR L=10+5/8"	
all	11	03 01420A	DOOR STRIKER=ILOC	
all	12	15G140	HXCAPNT 1/4-20 #C250=20 NKLPLT	
all	13	15K031	BUTSOKCAPSCR 1/4-20X1/2 SS18-8	
all	14	15U181	LOCKWASHER MEDIUM 1/4 SS18-8	
all	15	24G020N	ROLLED WASH.252ID NYLTITE 25W	
all	16	60C080	RECESS BUMPER RUBBERLAVELLE #7	
all	17	15P103	TRDCUT-F RDHDSLOT 8-32UNCX1/2	
all	18	15N173A	FLTMACSCR 1/4-20 UNCX5/8 UCUTS	
all	19	20C018	ADHESIVE-3M #1357-QT CN	
all	20	15Q077	SOKSETSCR 1/4-20X1/4 ZINC ALLE	
all	21	03 01423C	LATCH GUARD ILOC 3015-20	
all	22	02 02815	PLAIN BRG=DOOR HINGE-NYLON	
all	23	15U188	FLTWASH 1/4 STD COMM SS18-8	
all	24	15N191	FLATMACHSCR 1/4-20X7/8 SS18-8	
all	24	15N176	FLATMACSCR 1/4-20NCX3/4SS18-8	
all	25	02 09263	SHIM=SHELLDOOR LATCH, 36XX	
all	26	02 11904K	SHIM=DOOR HANDLE=4226RWP	

**Interlock Assembly
30015, 30022, 3621 C4E**

BMP020058/2005086V
(Sheet 1 of 4)



Pellerin Milnor Corporation
P. O. Box 400, Kenner, LA 70063-0400

Litho in U.S.A.

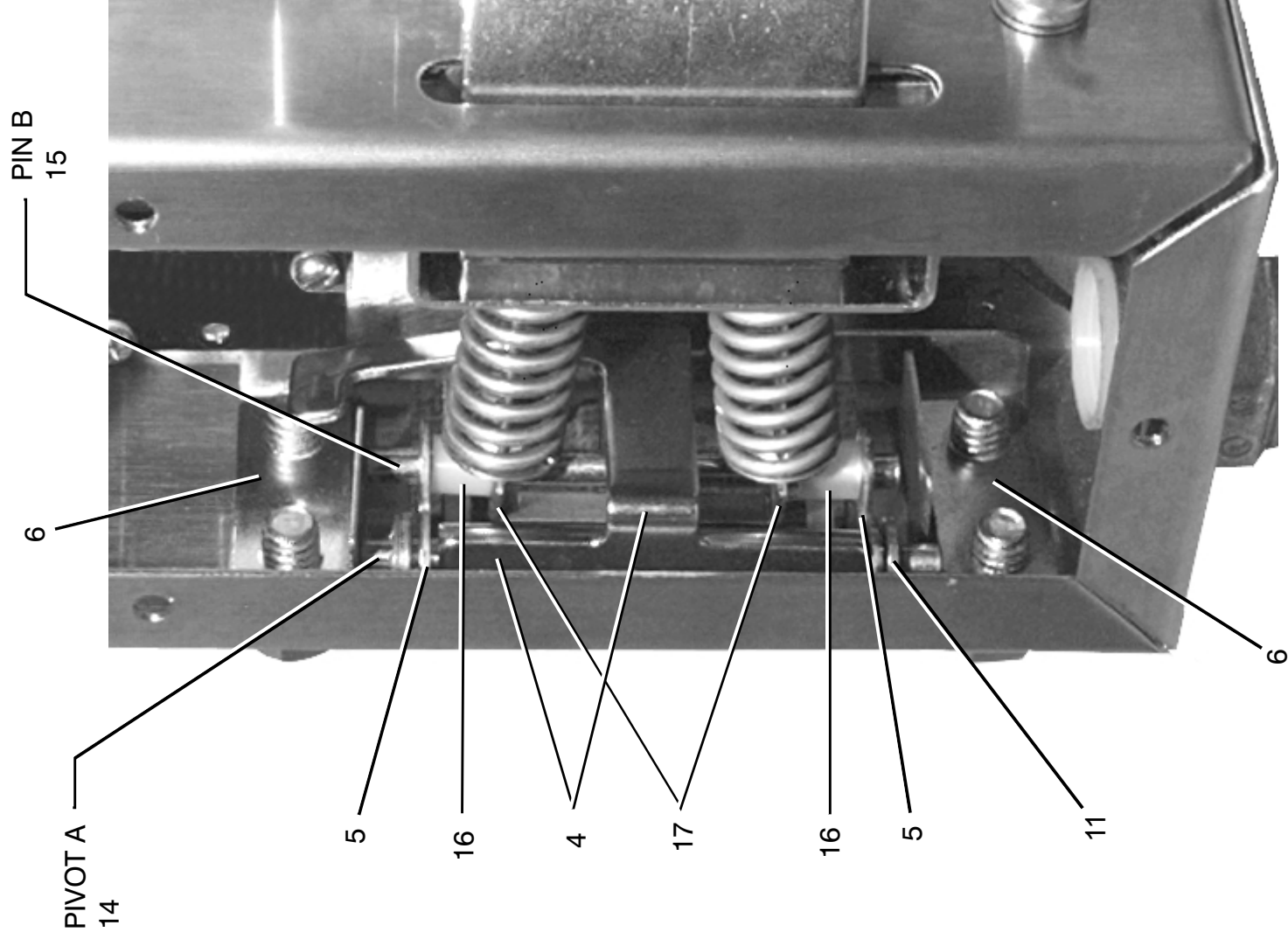
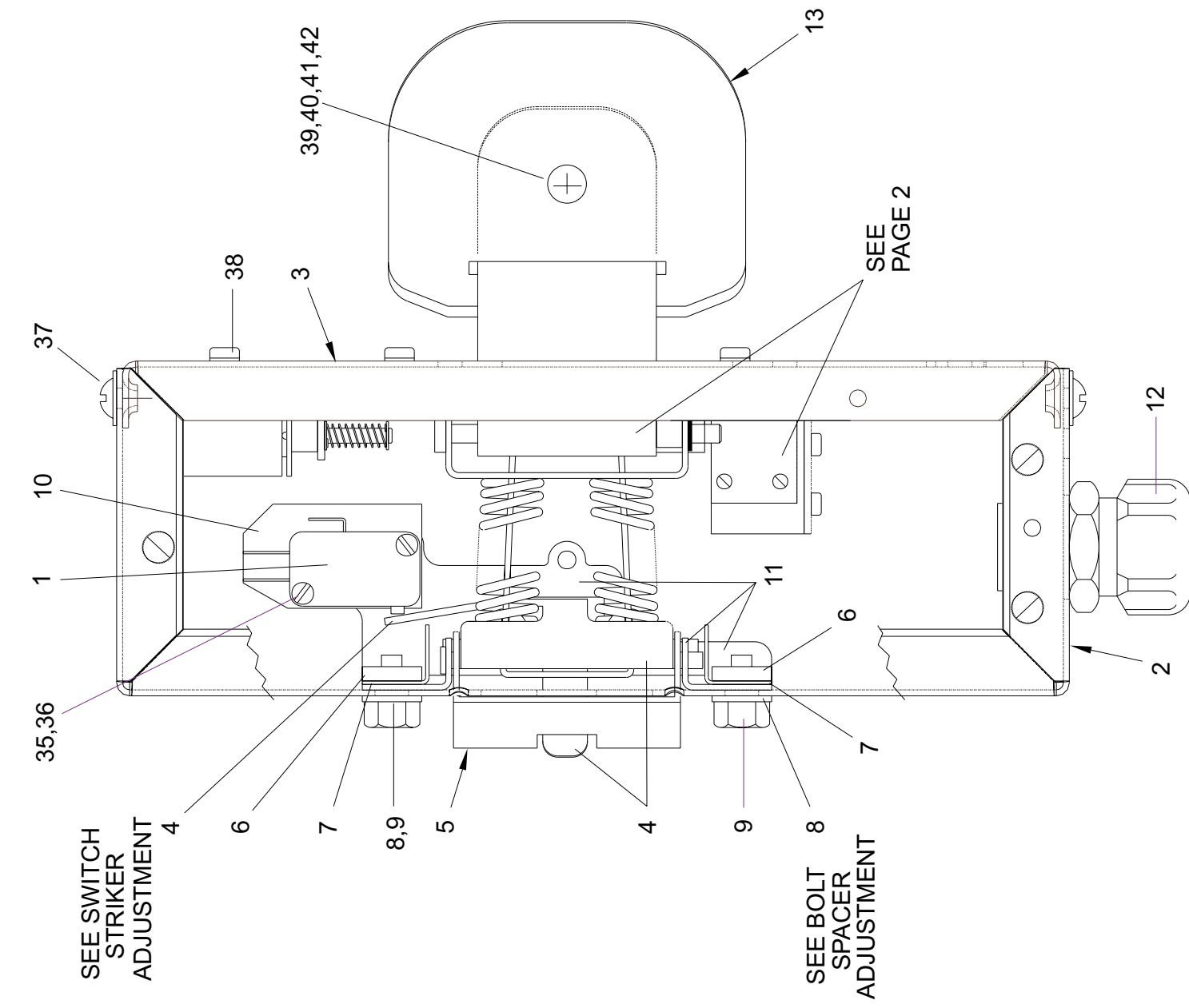

**Interlock Assembly
30015 & 30022 C4E**

BMP020058/2005086V
(Sheet 2 of 4)



Pellerin Milnor Corporation
P. O. Box 400, Kenner, LA 70063-0400

Litho in U.S.A.

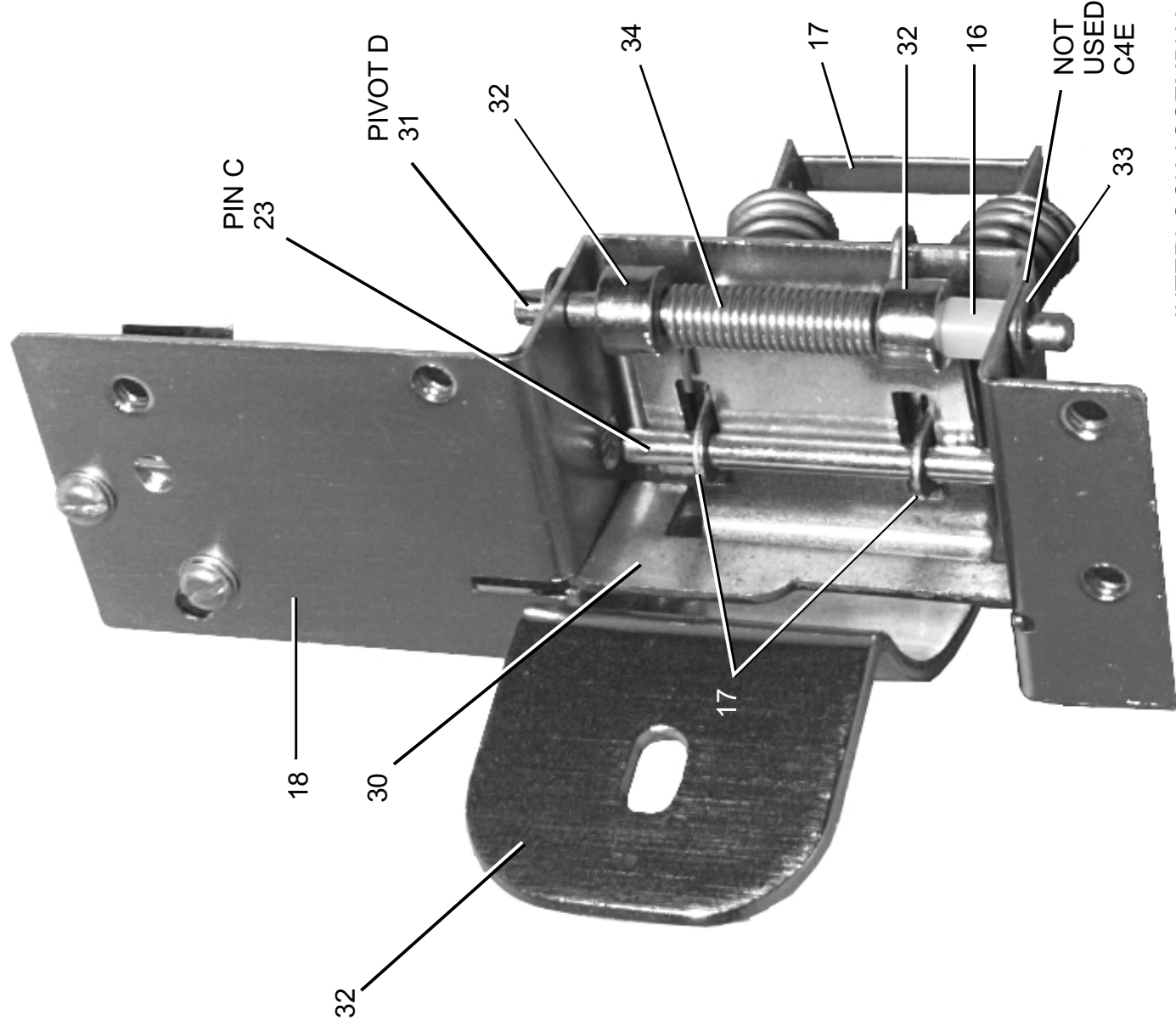

INTERLOCK ASSEMBLY
WITHOUT PROXIMITY
SWITCH SHOWN

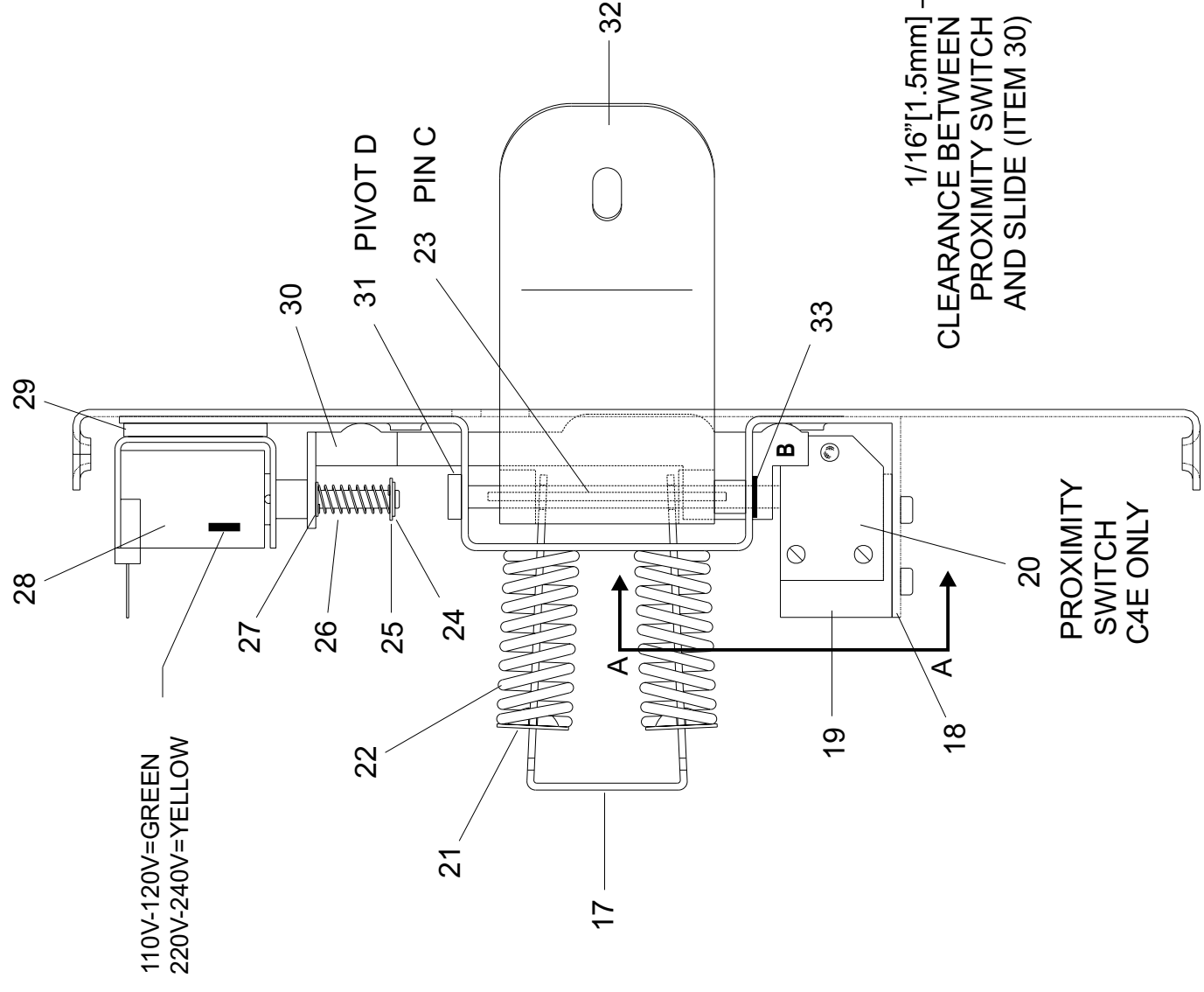

FRONT VIEW

PROXIMITY SWITCH
HAS TWO LED LAMPS:

GREEN = ON / ENERGIZED
ORANGE = CLOSED CIRCUIT

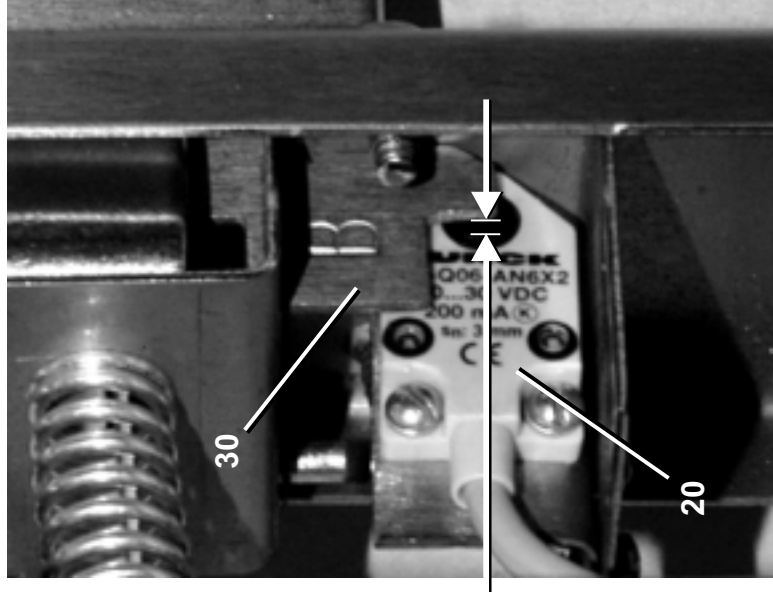

VIEW A-A

1/16" [1.5mm]
CLEARANCE BETWEEN
PROXIMITY SWITCH
AND SLIDE (ITEM 30)

PROXIMITY
SWITCH
C4E ONLY

Interlock Assembly 30015 & 30022 C4E



Pellerin Milnor Corporation
P. O. Box 400, Kenner, LA 70063-0400

BMP020058/2005086V
(Sheet 3 of 4)

Litho in U.S.A.

Parts List—Interlock Assembly
Find the correct assembly first, then find the needed components. The item letters (A, B, C, etc.) assigned to assemblies are referred to in the "Used In" column to identify which components belong to an assembly. The item numbers (1, 2, 3, etc.) assigned to components relate the parts list to the illustration.

Used In	Item	Part Number	Description	Comments
			ASSEMBLIES	
	A	EDL00171C	INTRKHSG ASSY=N/O W/ PROX 240	3015,3022C4E
	B	EDL00171B	ILOC PIVOT ASSY W/PROX 240V	PART OF A
	C	EDL00137C	INTRKHSG ASSY=N/O W/PROX 120V	3621C4E
	D	EDL00137B	I-LOC PIVOT ASSY=W/PROX 120V	PART OF C
			COMPONENTS	
all	1	09R014A	MINI-SW SPDT STAKON #V15G1C26K	
all	2	03 01426B	HOUSE=REAR ILOC W/PROX	
all	3	03 01427C	HOUSING=REAR ILOC W/PROX	
all	4	03 01424A	STRIKER=SWITCH=LONG TAB	
all	5	03 01423	LATCH = INTERLOCK	
all	6	03 01418B	KEEPER=LATCH PIN/NOTCH	
all	7	03 01418	TAP STRIP = ELEC INTER LOCK	
all	8	03 01417	PLATE=SPACER=ILOC	
all	9	15N158	HEXCAPSCR 1/4-20NCX1/2SS18-8	
all	10	03 01335	INSULATOR=AIROP AUTOSPOT+\$8S	
all	11	03 01429	PLATE=FNT PIVOT = ILOC	
all	12	12K040	1/2"COND.EMT COND. PECO #260B	
all	13	03 01425A	DOOR HANDLE EXTENSION	
all	14	03 01443	FLATHDRIVET 5/32X2+5/16 ZINC	
all	15	15H091	STRGHTPIN 5/32"X2.25 LG ZINC	
all	16	27B205080Z	SPCRROLL.177ID.218L.027T STLZC	
all	17	03 01422	KEEPER=SPRING=ILOC	
all	18	03 01428C	PLT=RR PIVOT ILOC+PROX 220V	
all	19	03 01428B	XROX BKT=REAR PIVOT ILOC N/O	
all	20	09RPS03RDS	3MM SENSING RECTANGULAR SHLD	
all	21	03 01444A	SPRING CUP = ILOC	
all	22	03 01444	SPRING .51/1.69/46+CADPL	
all	23	15H090I	STPIN 5/32 X DIA 1.75"LG ZN.	
all	24	17B171	EXTRETRING IND#6100-9-ST-ZD ZI	
all	25	15U063	FLATWASH STD #6 EXCEPT.010THK	
all	26	03 01445	SPRING .2/625/.319+CADPL	

SWITCH STRIKER ADJUSTMENT

Adjust the switch striker arm by bending as shown so that :

- 1) The switch is activated when the door is closed
- 2) The switch does not actuate when the unlatching lever is fully depressed with the door open
- 3) The arm does not over travel and hit the switch housing when the door is closed and the switch is actuated.

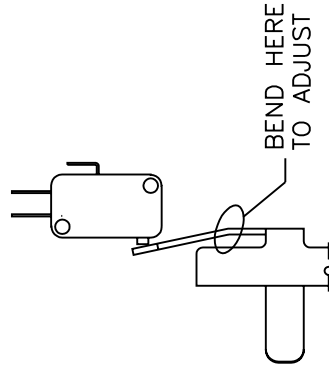

BOLT SPACER ADJUSTMENT

Bolt Spacer Adjustment

- 1) On a new machine the slots on the front housing should not show a gap past the bolt spacers.
- 2) The spacers should be installed with the long side toward the shellfront

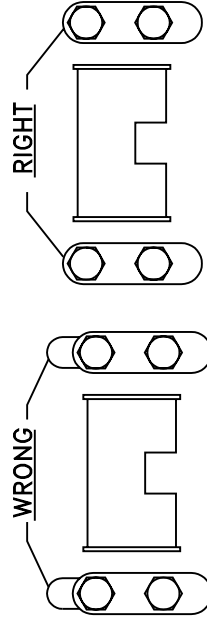



Pellerin Milnor Corporation
P. O. Box 400, Kenner, LA 70063-0400

Litho in U.S.A.

Parts List, cont.—Interlock Assembly

Used In	Item	Part Number	Description	Comments
all	27	15U060	FLAT WASHER#6 ANSI TYPEB BRASS	
B	28	09K062B71	SOLENOID 240/60--220/50 = ILOC	
D	28	09K062B37	SOLENOID(C-7)120/60--110/50	
all	29	03 S1X1	SHIM:DOOR INTLK SOLENOID N4P	
all	30	03 01421B	SLIDE=NORMALLY OPEN(C7 SOL)	
all	31	03 01443	FLATHDRIVET 5/32X2+5/16 ZINC	
all	32	03 01425	HANDLE=ILOC	
all	33	17B170	EXTRETRING IND#6100-15-ST-ZD Z	
all	34	03 01445B	TORQUE SPRING (.53 IN-#)	
all	35	15N019	RDMACSCR 4-40UNC2AX5/8 ZINC GR	
all	36	15U040	LOCKWASHER MEDIUM #4 ZINCPL	
all	37	15N080S	PANHDPHILMACSCRSEMS8-32X1/4SS	
all	38	15P010S	TRDCUTPNHD SEMS 10-24X1/2 SS41	
all	39	15G130	HEXMACHSCRNUT 10-24UNC2 SS18-8	
all	40	15N123C	FLATMACHSCR 10-24X7/16 U-CUT S	
all	41	15U160	LOCKWASHER MEDIUM #10 SS18-8	
all	42	15U135	FLATWASH#10 .4370DX.203IDX.04T	
all	43	03 01442	SOLENOID INSULATION=DR INTRK	

Section
Control and Sensing

5

Level Switches 3010 & 3015 G5E,G5X,CGE

BMP040013/2004055V
(Sheet 1 of 1)



Pellerin Milnor Corporation
P. O. Box 400, Kenner, LA 70063-0400

Litho in U.S.A.

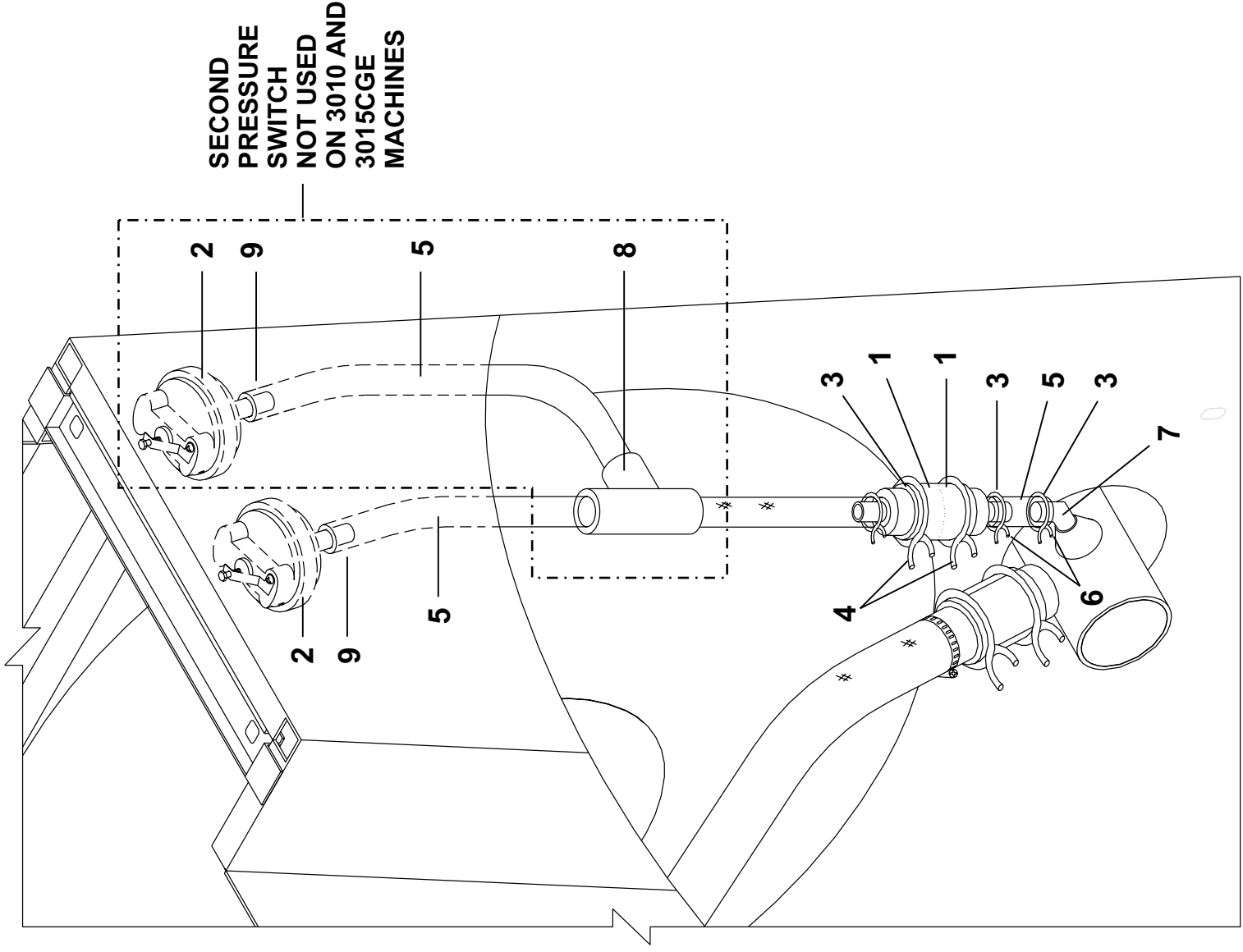

Parts List—Level Switches
Find the correct assembly first, then find the needed components. The item letters (A, B, C, etc.) assigned to assemblies are referred to in the "Used In" column to identify which components belong to an assembly. The item numbers (1, 2, 3, etc.) assigned to components relate the parts list to the illustration.

Used In	Item	Part Number	Description	Comments
			ASSEMBLIES	
A		GPS30001	PRESS SWITCH/CHAMBER INSTALL	G5X
B		GPS30002	C4 PRESSURE SWITCH/CHMBER INST	CGE
C		GPS30003	3010/15 PRESSURE CHAMBER INST	G5E
			COMPONENTS	
all	1	02 03332C	AIRCHAMBER=PRESSWITH-CWU	
all	2	09N086A	PRESS SW INVENSYS #738-761	
all	3	60E014A02A	HOSE 1.25IDX2"LG PVC	
all	4	27A052	HOSECLMP 1.5"DIA.SPRG#HC24STZD	
all	5	60E005P	PVC TUBING 1/2"ID X 5/8"OD	
all	5	60E006C	PVC TUBING NYL.REINF.5IDX.75OD	
all	6	27A043A	HOSECLAMP.562"DIA.SPRG#HC9STZD	
all	7	51E509P	1/2HX1/4NPT HOSE ADAPT 90ELB	
all	7	5SL0EP8K	NPT ELB 45DEGFXF 1/4" PVC S80	
all	8	5S0KQ8A	TEE 1/2"SOC CTS CPVC BEIGE	
all	8	51E509Y	Y-CONN1/2"HBARB PLAS.IND#64017	
all	9	27A044B	HOSECLMP.625"ID SPRNG#HC10ST-G	
all	9	27A045	HOSECLAMP .750"DIA SPRINGTYPE	

VIBRATION SAFETY SWITCH ADJUSTMENTS

B What the Vibration Safety Switch Does

The *vibration safety switch* pictured below is an important safety feature. If properly adjusted, the switch will momentarily actuate as a result of repeated machine movement caused by an out-of-balance condition. Table A below illustrates the effect of the *vibration safety switch* actuation.

Table A—Effect of Tripping Vibration Safety Switch

Machine Model	Function of Vibration Safety Switch
30015, 30020, and 30022	Disables high speed extract
All microprocessor-controlled washer-extractors not listed above, and all dye machines	De-energizes three-wire relay, effectively terminating machine operation

Adjustments

When the machine leaves Milnor[®], the actuator arm is tie-wrapped to prevent damage (except on 30015, 30020, and 30022 models). **This tie wrap must be removed after the machine is set into position but before the machine is operated.**

Adjustment of this switch from the factory setting is not recommended; however, it should be checked for proper functioning and adjusted if its proper setting is lost.

As shown at right in FIGURE 1, the unit consists of a *sensitive micro-switch* with an extended actuating arm supporting an eccentric weight. The weight may be adjusted by moving it up and down on the arm and by rotating it on the arm. In addition, the *micro-switch* itself may be tilted from side to side.

The sensitivity of the switch increases as the eccentricweight is raised on the actuating arm and decreases as the weight is lowered.

The unit should be adjusted so that the actuating arm will always reset by itself, this being accomplished by rotating either the switch or the weight to give just enough bias to cause the switch to reset. Check the adjustment by moving the arm to the left then slowly releasing it. Make sure the micro-switch clicks when the arm is **slowly** released, thus indicating

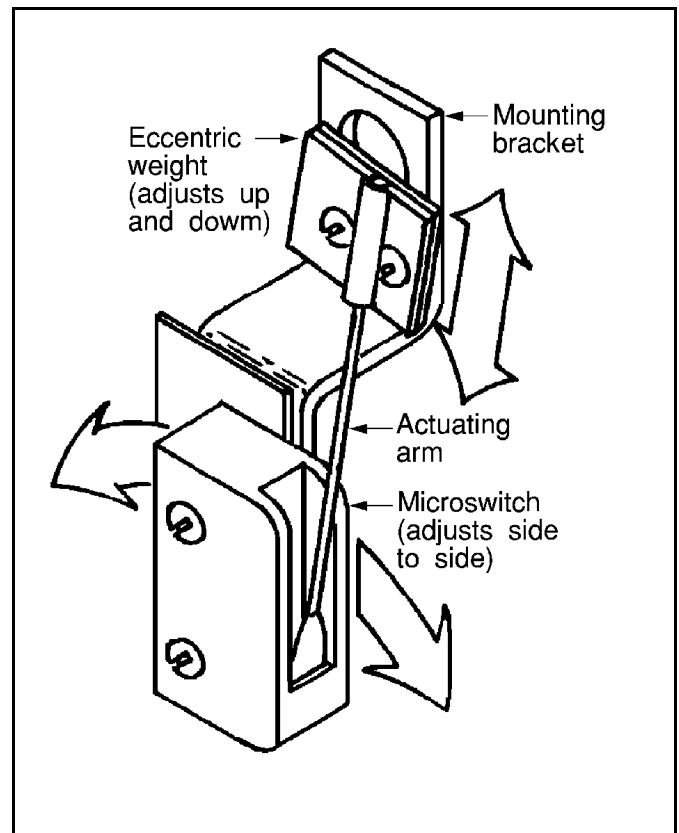

FIGURE 1 (MSSMA408BE)
Vibration Switch

that it has reset. In the released position the arm should rest **lightly** but definitely against the stop on the *micro-switch* case that prevents any further arm movement to the left.

For machines with rigid mounted shells, where the machine is bolted to a very substantial foundation, very little machine movement will occur for a given degree of out-of-balance. Under such conditions it may be better to adjust the switch to be very sensitive. With less substantial foundations (e.g., ones where the sub-soil is mushy or springy or otherwise not as desirable), considerably greater machine movement will occur for a given degree of out-of-balance, in which case a less sensitive *vibration switch* setting may be indicated.

Vibration Safety Switch

BMP040014/2004055V
(Sheet 1 of 1)



Pellerin Milnor Corporation
P. O. Box 400, Kenner, LA 70063-0400

Litho in U.S.A.

Parts List—Vibration Safety Switch

Find the correct assembly first, then find the needed components. The item letters (A, B, C, etc.) assigned to assemblies are referred to in the "Used In" column to identify which components belong to an assembly. The item numbers (1, 2, 3, etc.) assigned to components relate the parts list to the illustration.

Used In	Item	Part Number	Description	Comments
			-----ASSEMBLIES-----	
	A	SAE03 151C	* ASY-VIBRAT SWT=LG CNTR NC/NO	3010 & 3015G5E,G5X,CGE 3015 & 3022 C4E 3015 & 3022 T5E
			-----COMPONENTS-----	
all	1	02 02038	PLATE INSULATING SMALL9NOV51	
all	2	15P008	TRDCUT PANHD 6-32X1 NIKSTL +WA	
all	5	02 15119	BRACKET=VIBSW CAD	
all	6	09R020A	SW NO/NC VIBRA#BZ-2RW84429-P52	
all	7	03 01059	VIBSWITCH CLAMP CADSTL	
all	8	03 01058	VIBSWITCH WEIGHT-CADSTL	
all	9	15P100	#8 X 3/8 PHILPANHD TYPE B SMS	

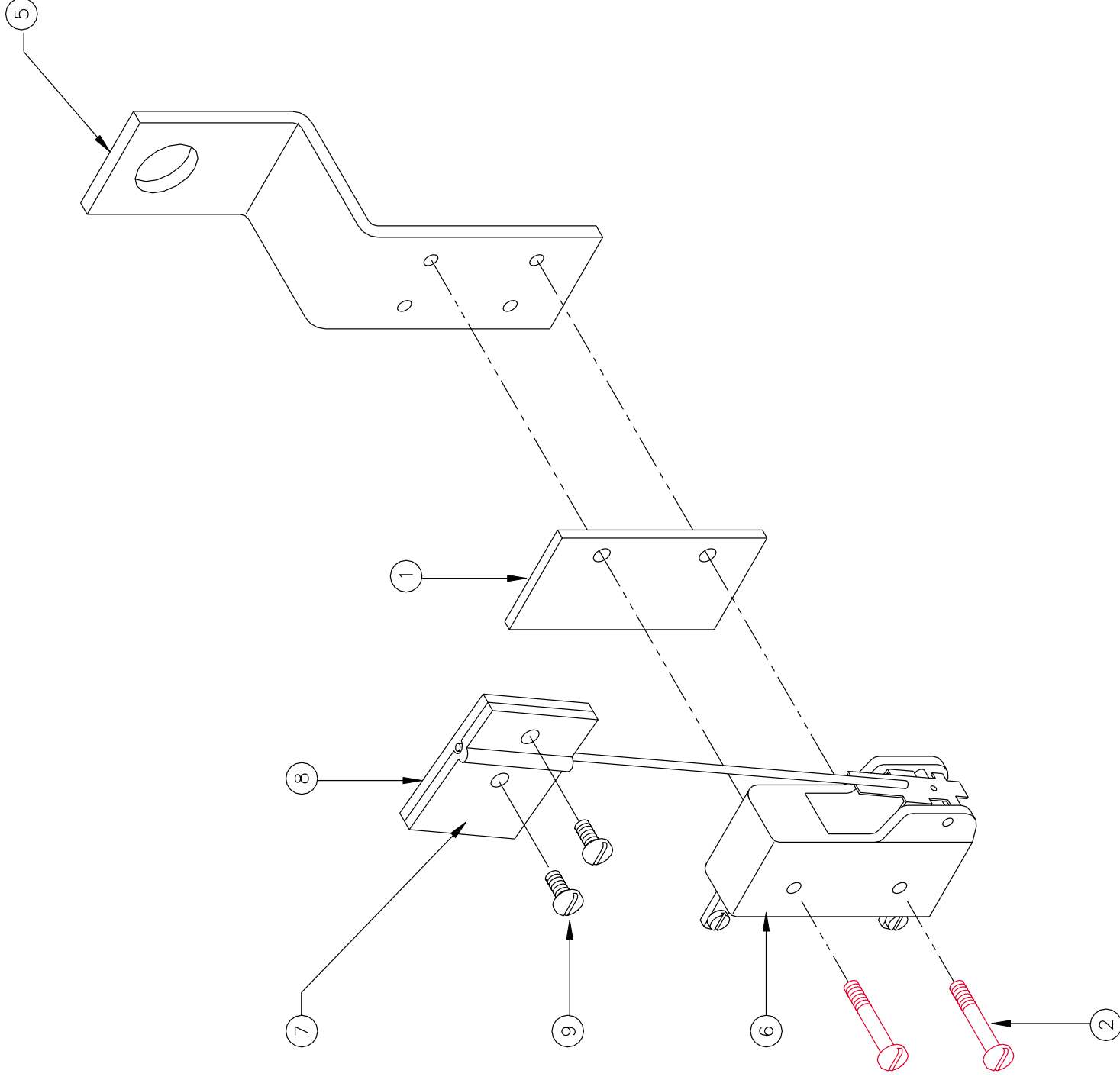

Section
Chemical Supply

6

Peristaltic Supply Box

3010 & 3015 G5E,G5X,CGE

30015V7J,T5J,T5E,T5X,C4A,C4T 30022V6J,T5J,T5E,T5X,C4A,C4T

BMP000046/2004055V
(Sheet 1 of 1)



Pellerin Milnor Corporation
P. O. Box 400, Kenner, LA 70063-0400

Litho in U.S.A.

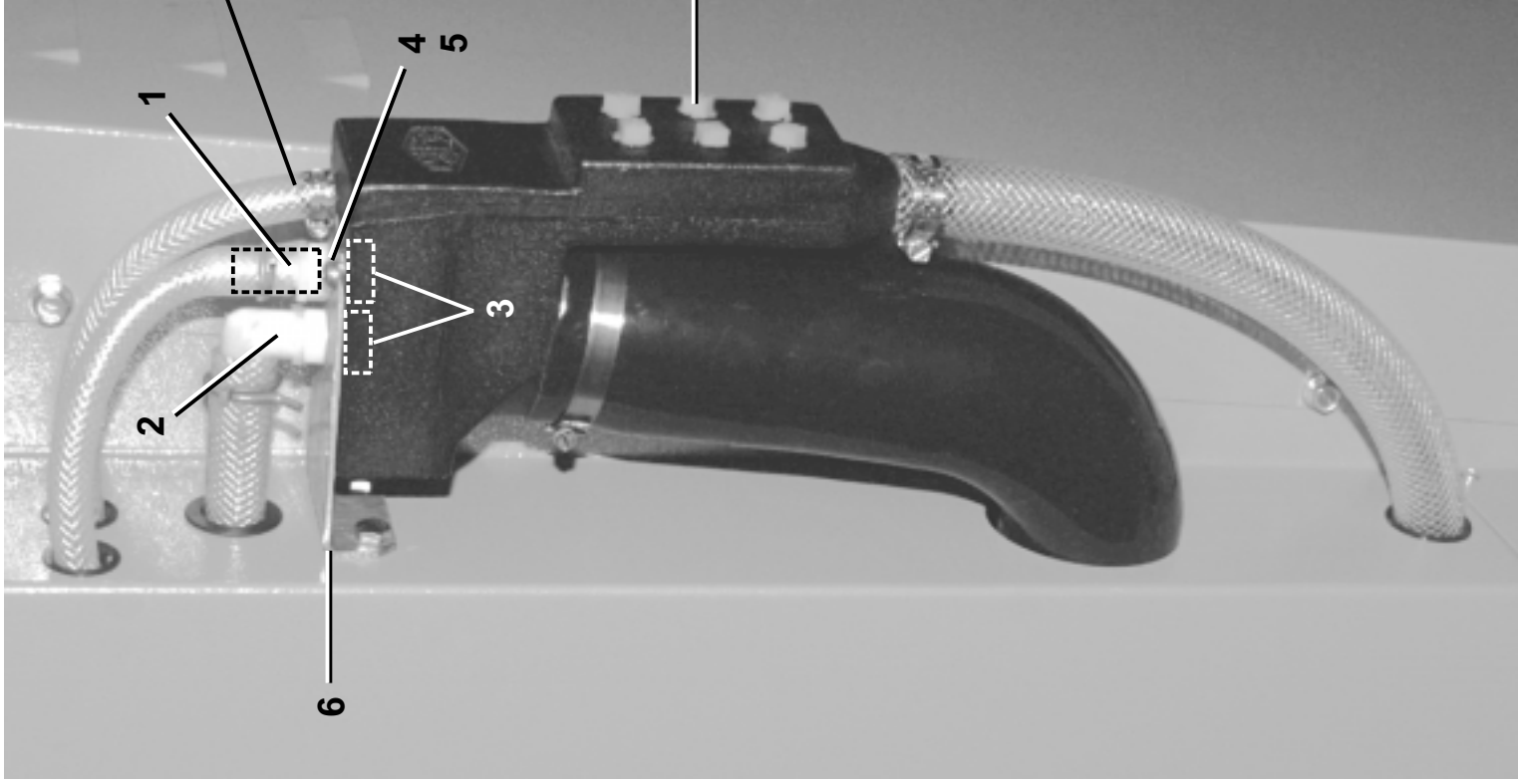

Parts List—Peristaltic Supply Box

Find the correct assembly first, then find the needed components. The item letters (A, B, C, etc.) assigned to assemblies are referred to in the "Used In" column to identify which components belong to an assembly. The item numbers (1, 2, 3, etc.) assigned to components relate the parts list to the illustration.

Used In	Item	Part Number	Description	Comments
			ASSEMBLIES	
A		SA 33 058P	ASSY=PLSTC PERSTL REAR INLET	
			COMPONENTS	
	1	51E513N	HOSEADPT3/4"HX11/16 W/NUT=NYL.	
	2	51E513EBN	3/4" 90DEG. ELBOW W/NUT	
	3	51E513NU	NUT 11/16 THRD.#64138 US PLAST	
	4	15K031	BUTSOKCAPSCR 1/4-20X1/2 SS18-8	
	5	15U181	LOCKWASHER MEDIUM 1/4 SS18-8	
	6	02 03588F	3015/20 PERST BOX TOP BRKT	
	7	02 03588E	PERISTALTIC/WATER INLET 30	
	8	51PB0GN	PLUG PIPE 3/8"NPT P-38 HD POLY	
	9	20C040	SIL SEAL RTV BLACK 85GR #59330	

Soap Chute Installation

3010 & 3015 G5E,G5X 3010 & 3015CGE
 30015V7J,T5J,T5E,C4A,C4T,C4E 30022V6J,T5J,T5E,C4A,C4T,C4E

BMP000040/2004055V
 (Sheet 1 of 1)



Pellerin Milnor Corporation
 P. O. Box 400, Kenner, LA 70063-0400

Litho in U.S.A.

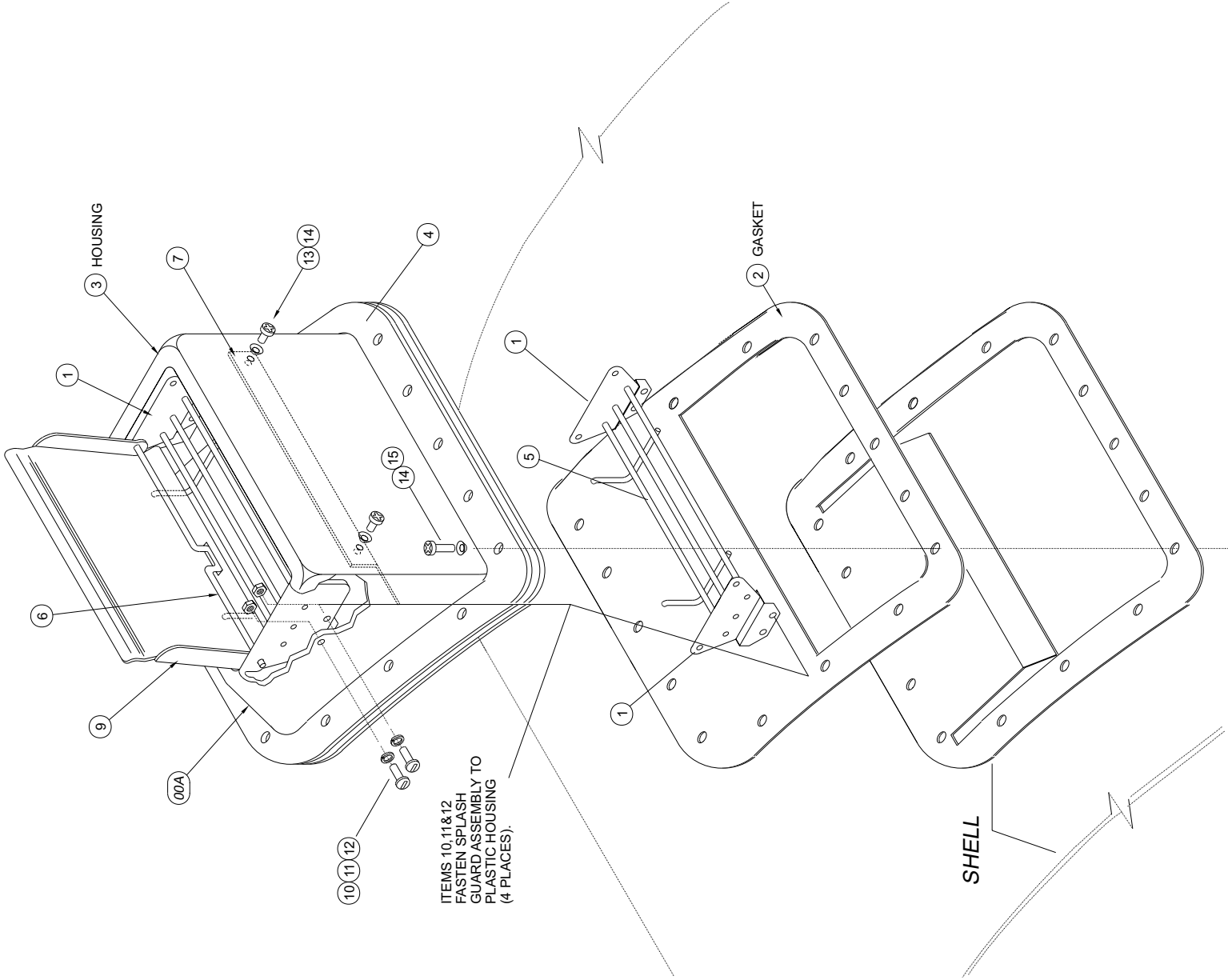

Parts List—Soap Chute Installation
 Find the correct assembly first, then find the needed components. The item letters (A, B, C, etc.) assigned to assemblies are referred to in the "Used In" column to identify which components belong to an assembly. The item numbers (1, 2, 3, etc.) assigned to components relate the parts list to the illustration.

Used In	Item	Part Number	Description	Comments
	A	SA-33-058M	94000Z ASSEMBLY=PLSTC SOAP INLET	
			ASSEMBLIES	
			COMPONENTS	
all	1	02 03130	BRACKET=PLASTIC SOAP INLET	
all	2	02 03304D	GASKET=SOAPCHUTE 1/8"EPDM BL	
all	3	02 03589I	PLASTIC SHELLSIDE SOAP INLET	
all	4	02 03589T	BACKING RING=PLSTC CHEM INLT	
all	5	02 03594	GUARD SOAP CHUTE=CWU	
all	6	02 03595	PIN SOAP CHUTE HINGE=CWU	
all	7	02 03630A	SPLASH GUARD= SOAP CHUTE	
All	9	02 03593	89432B LID-SOAPCHUTE CWE TY304 SS	
all	10	15N133	RDMACSCR 10-24UNCZA X5/8" SS18	
all	11	15U160	LOCKWASHER MEDIUM #10 SS18-8	
all	12	15G130	HEXMACHSCRNUT 10-24UNC2 SS18-8	
all	13	15P050	PHDCUT-F PANHD 10-32X3/4 SS410	
all	14	24G018N	ROLLED WASH.194ID NYLTITE 10W	
all	15	15P051	TRDFRM AB HOLTHD 10-16X3/4SS41	

Section
Water and Drain

7

Schematic Symbols Key

BMP920008/2000302V
(Sheet 1 of 1)



Pellerin Milnor Corporation
P. O. Box 400, Kenner, LA 70063-0400

Litho in U.S.A.

ISOMETRIC SYMBOLS

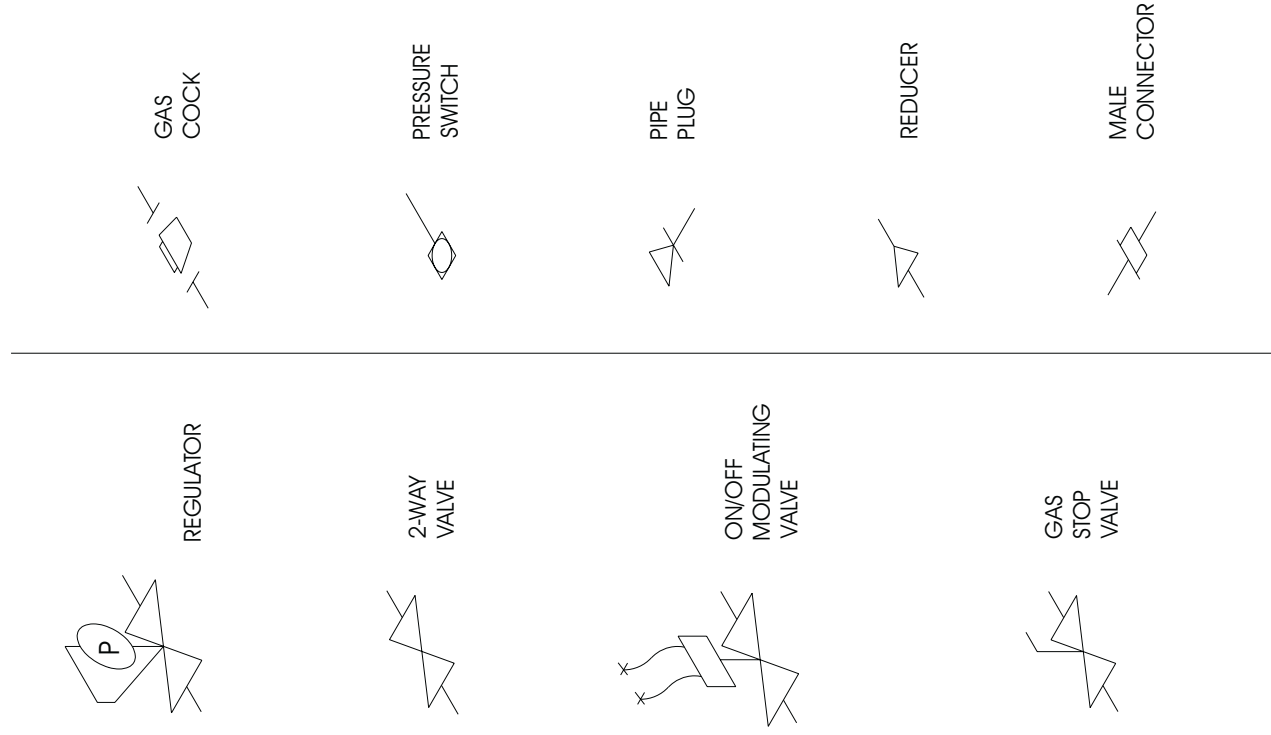

STANDARD SYMBOLS

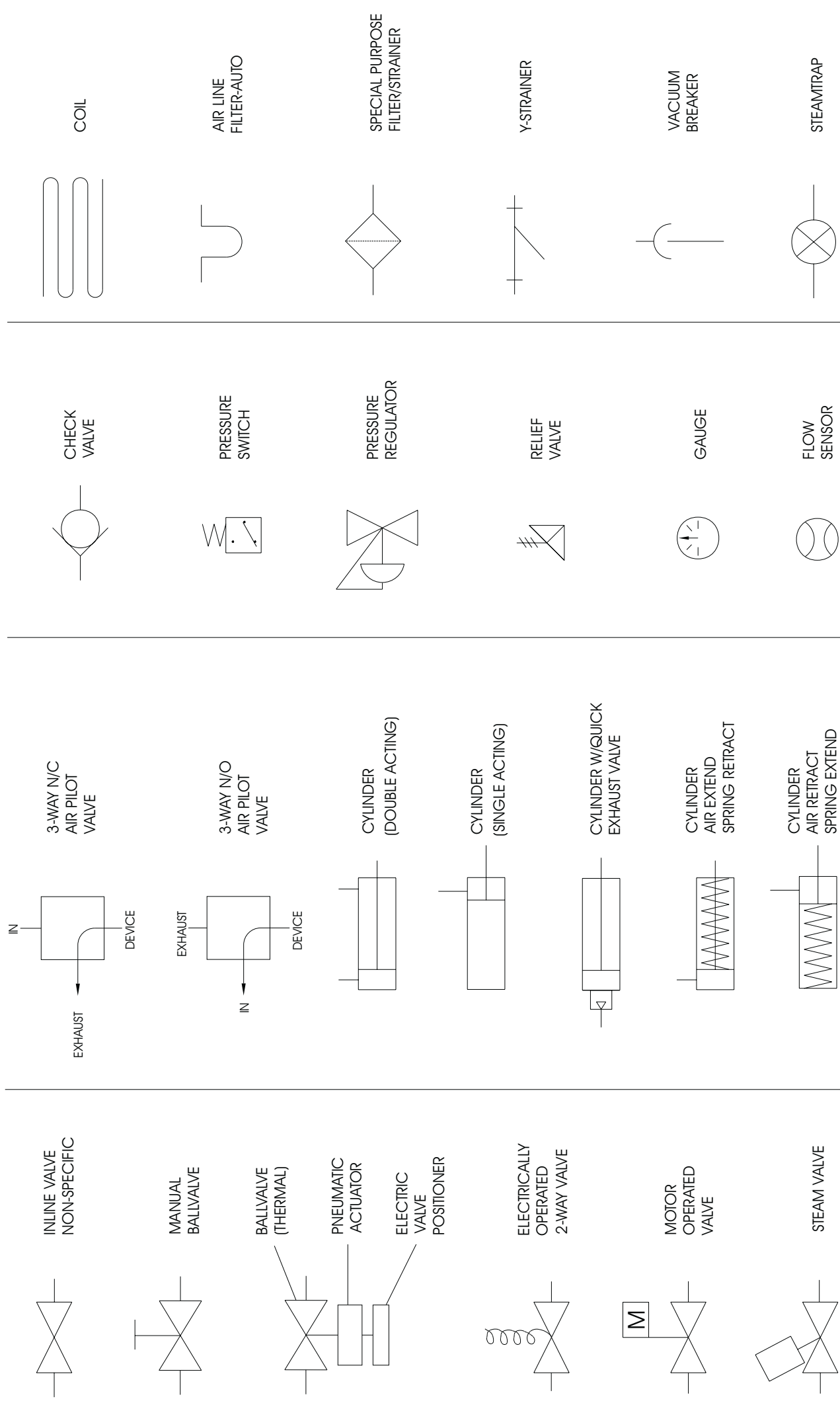

Water Schematics

3010 & 3015G5E,G5X,CGE

BMP040012/2004055V
(Sheet 1 of 1)



Pellerin Milnor Corporation
P. O. Box 400, Kenner, LA 70063-0400

Litho in U.S.A.

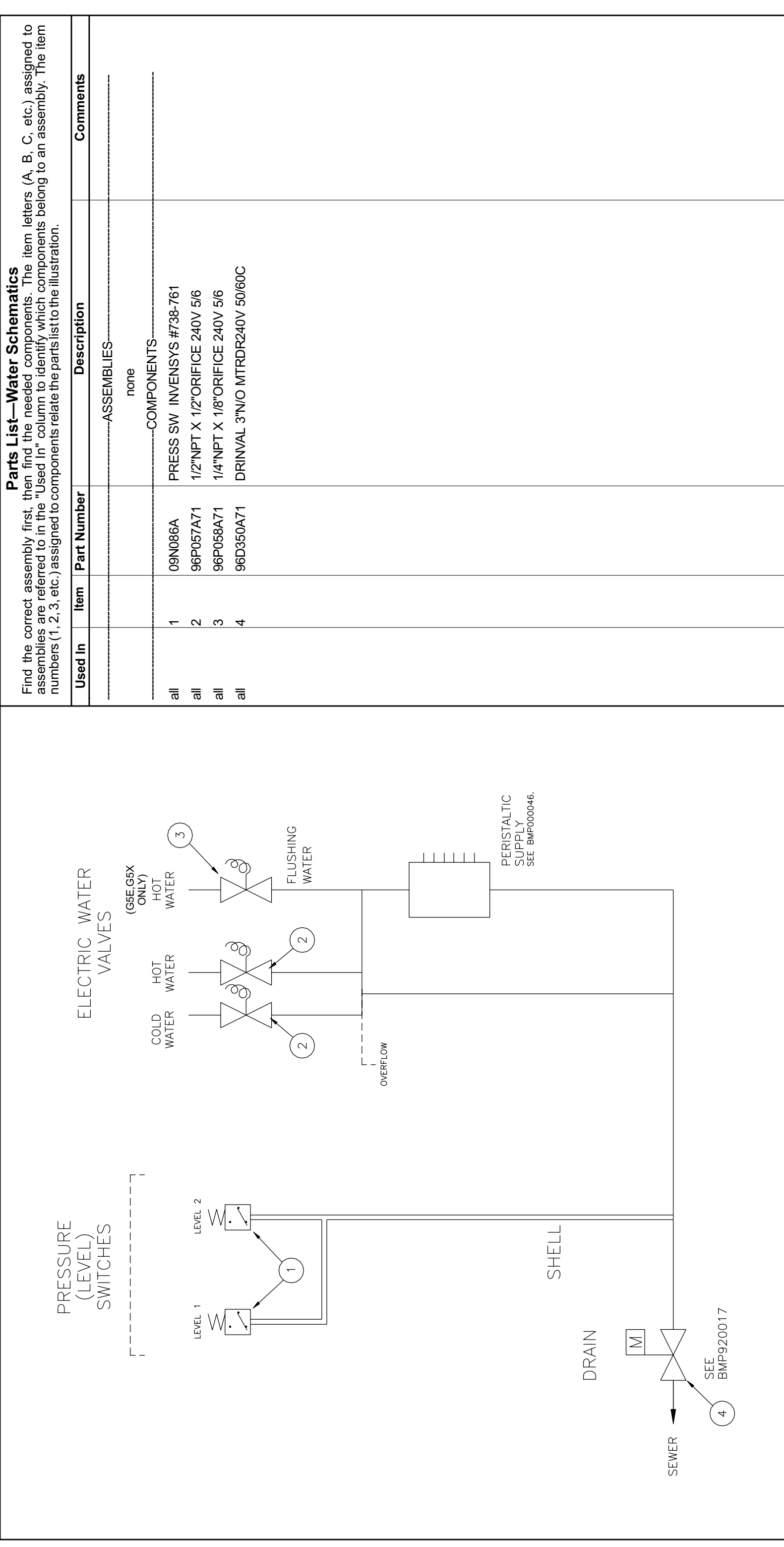

Parts List—Water Schematics
Find the correct assembly first, then find the needed components. The item letters (A, B, C, etc.) assigned to assemblies are referred to in the "Used In" column to identify which components belong to an assembly. The item numbers (1, 2, 3, etc.) assigned to components relate the parts list to the illustration.

Used In	Item	Part Number	Description	Comments
			ASSEMBLIES	
			none	
			COMPONENTS	
all	1	09N086A	PRESS SW INVENSYS #738-761	
all	2	96P057A71	1/2"NPT X 1/2"ORIFICE 240V 5/6	
all	3	96P058A71	1/4"NPT X 1/8"ORIFICE 240V 5/6	
all	4	96D350A71	DRINVAL 3"N/O MTRDR240V 50/60C	

Water Inlet Assemblies with Peristaltic Supply

3010 & 3015 G5E, G5X

BMP040009/2004055V
(Sheet 1 of 2)



Pellerin Milnor Corporation
P. O. Box 400, Kenner, LA 70063-0400

Litho in U.S.A.

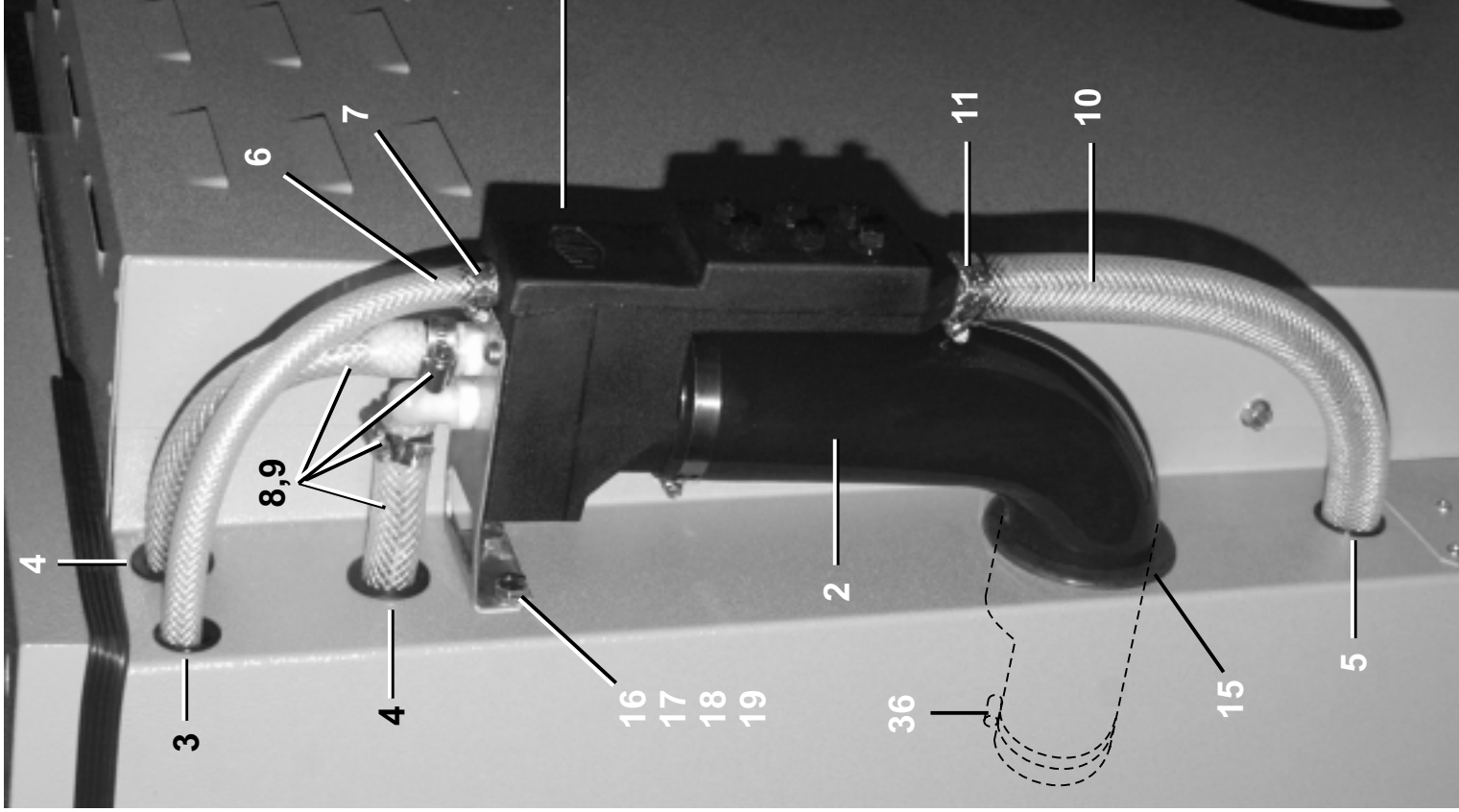

1 (SEE
BMP000046)

PERISTALTIC
SUPPLY

20
(6 PLACES)

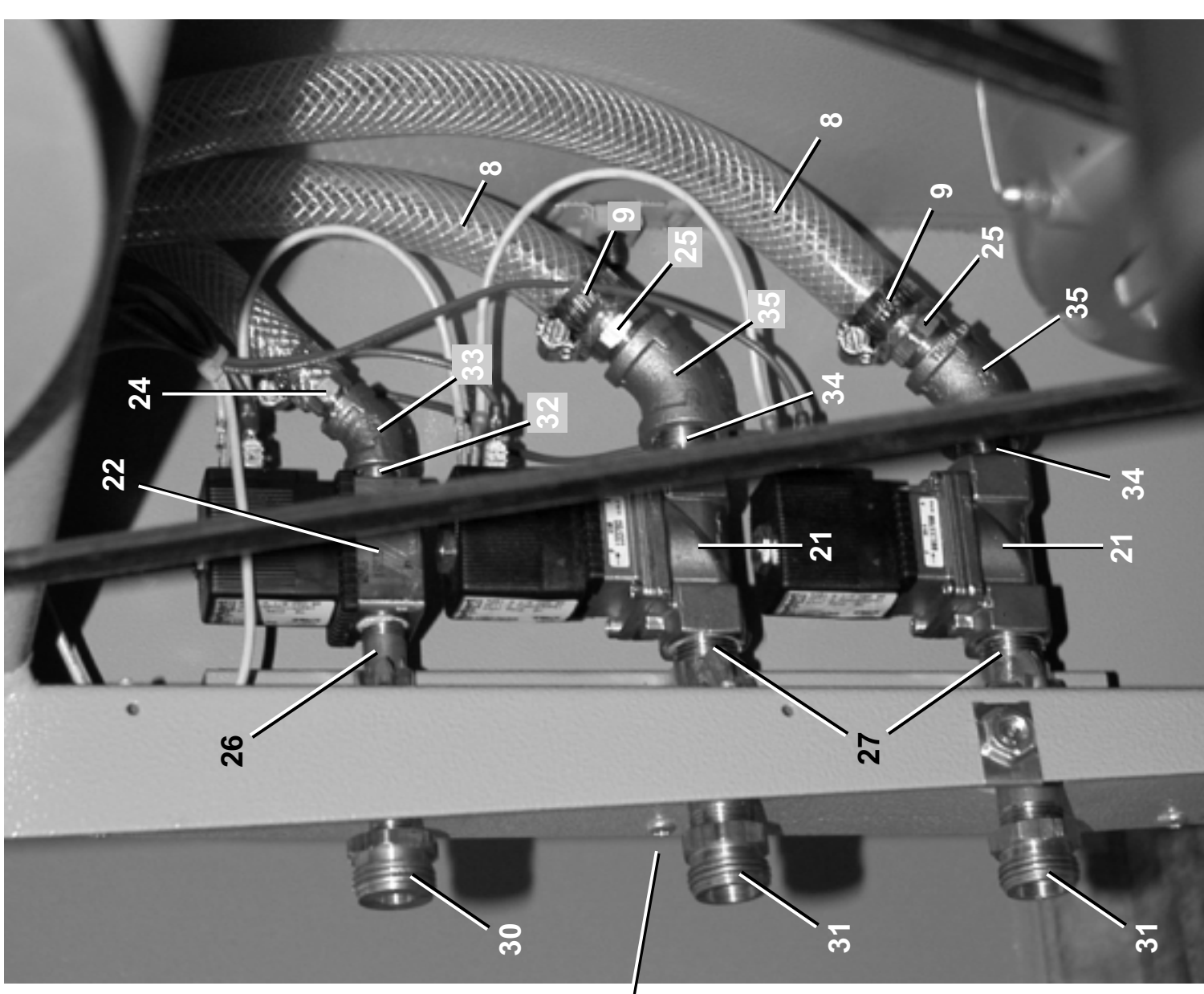
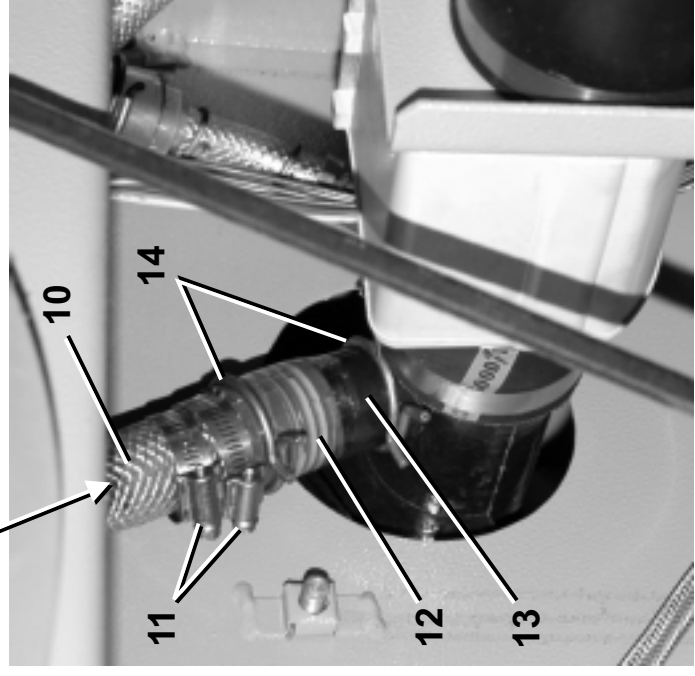

Water Inlet Assemblies with Peristaltic Supply

3010 & 3015 G5E, G5X

BMP040009/2004055V
(Sheet 2 of 2)



Pellerin Milnor Corporation
P. O. Box 400, Kenner, LA 70063-0400

Litho in U.S.A.

Parts List—Water Inlet Assemblies
Find the correct assembly first, then find the needed components. The item letters (A, B, C, etc.) assigned to assemblies are referred to in the "Used In" column to identify which components belong to an assembly. The item numbers (1, 2, 3, etc.) assigned to components relate the parts list to the illustration.

Used In	Item	Part Number	Description	Comments
			ASSEMBLIES	
	A	GA 33 058Y	INST=H2O+PERSTAL INLET 3010	
	B	SA 33 058T	3015/22 BRASS WATER VALVE ASSY	
			COMPONENTS	
all	1	SA 33 058P	ASSY=PLSTC PERSTL REAR INLET	
all	2	02 03588U	PERIS/WATER INLETHOSE 3010	
all	3	12P11CSB	SNAPBUSH 1.093"MH X .94"ID	
all	4	12P11KSB	SNAPBUSH 1.50" X 1.312	
All	5	12P11JSB	SNAPBUSH 1.50"MH X 1.312	
all	6	60E006C	PVC TUBING NYL.REINF.5IDX.75OD	
all	7	27A044	HOSECLAMP 5/8"ID BREEZE#6706SS	
all	8	60E008A	TUBINGNYLREINF.75"IDX1.025"OD	
all	9	27A044S	HOSECLAMP 11/16-1.25SSCR#64012	
all	10	60E010	TUBINGPOLYBRAID 1"X1.312	
All	11	27A090S	HOSECLAMP 13/16-1.5"SS#64016B	
all	12	51AB1EN1A	INSERT REDUCER PVC 1+1/4"X 1"	
all	13	60E014A02A	HOSE 1.25IDX2"LG PVC	
all	14	27A052	HOSECLAMP 1.5"DIA.SPRG#HC24STZD	
all	15	60C121	GROMMET-FILLTUBE3015/22	
all	16	15G205	HXNUT 3/8-16UNC2B ZINC GR2	
all	17	15U240	FLATWASHER(USS STD) 3/8" ZNC P	
all	18	15U255	LOCKWASHER MEDIUM 3/8 ZINCPL	
all	19	15K085	HEXCAPSCR 3/8-16UNC2AX3/4 GR5	
all	20	15P011	TRDCUT-F PANHD 10-24X1/2 NIKST	
all	21	96P057A71	1/2"NPT X 1/2"ORIFICE 240V 5/6	
all	22	96P058A71	1/4"NPT X 1/8"ORIFICE 240V 5/6	
all	23	W2 03588S	3015/22 BRASS H20 MNT WLMT	
all	24	51E507	HOSESTEM BRASS 1/4MPX1/2HOSEID	
all	25	51E510	HOSESTEM BRASS 1/2MPX3/4HOSEID	
all	26	5N0E03KBE2	NPT NIP 1/4X3.5 TBE BRASS STD	
all	27	5N0K03KB42	NPT NIP 1/2X3.5 TBE BRASS STD	
all	28	27A0650CLP	TUBING CLP 1/2"OD #PS1200-1/2	
all	29	27A0050	CLP-RGDSTL COND #PS1100-1/2	
all	30	51E513A	3/4"MHX1/4"FP PARKER#78GH-12-4	
All	31	51E513B	3/4"MHX1/2"FP PARKER#80GH-12-8	
all	32	5N0ECLSBE2	NPT NIP 1/4XCLS TBE BRASS 125#	
all	33	5SLOEBEK	NPT ELB 45DEG 1/4"BRASS 125#	
all	34	5N0KCLSBE2	NPT NIP 1/2XCLS TBE BRASS STD	
all	35	5SLOKBEK	NPT ELB 45DEG 1/2 BRASS 125#	
all	36	27A082S	HOSECLAMP 2+9/16-3.5SS305SCR	

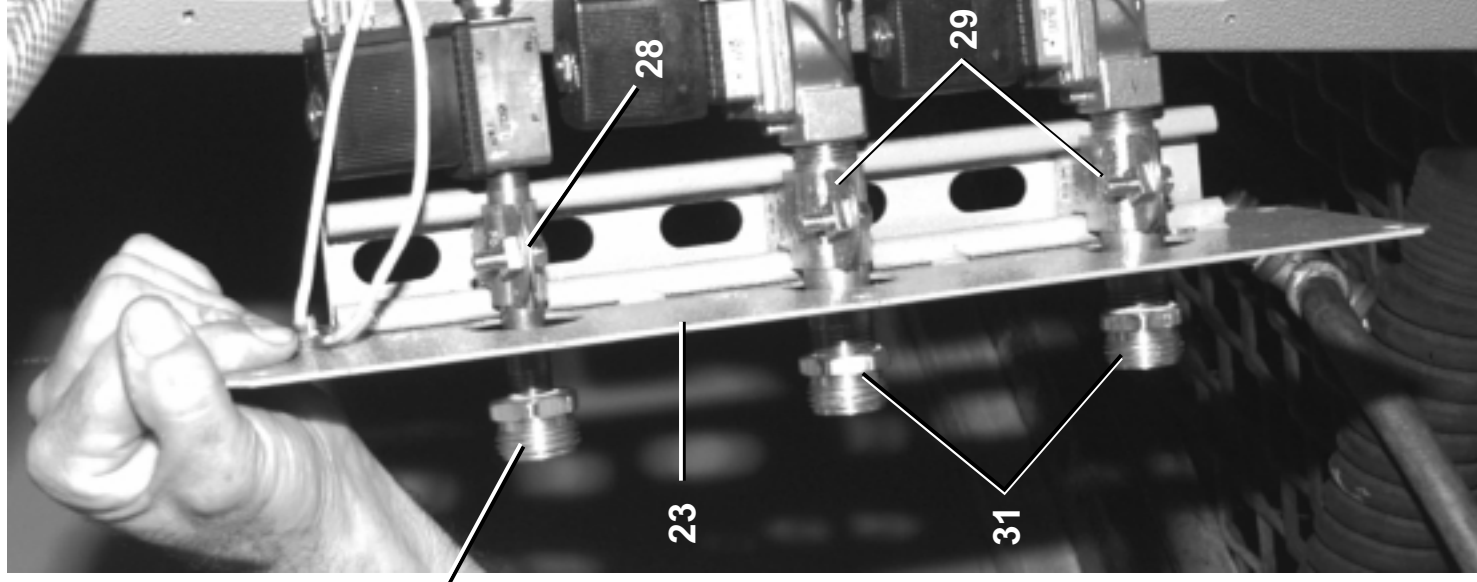

30

23

28

29

31

Drain Sump Installation
3010 G5E,G5X,CGE; 3015G5E,G5X,CGE
30015, 30022Vxx, Txx, C4A, C4T, C4E; 30015, 30020, 30022Qxx

BMP920014/2004055V
 (Sheet 1 of 1)



Pellerin Milnor Corporation
 P. O. Box 400, Kenner, LA 70063-0400

Litho in U.S.A.

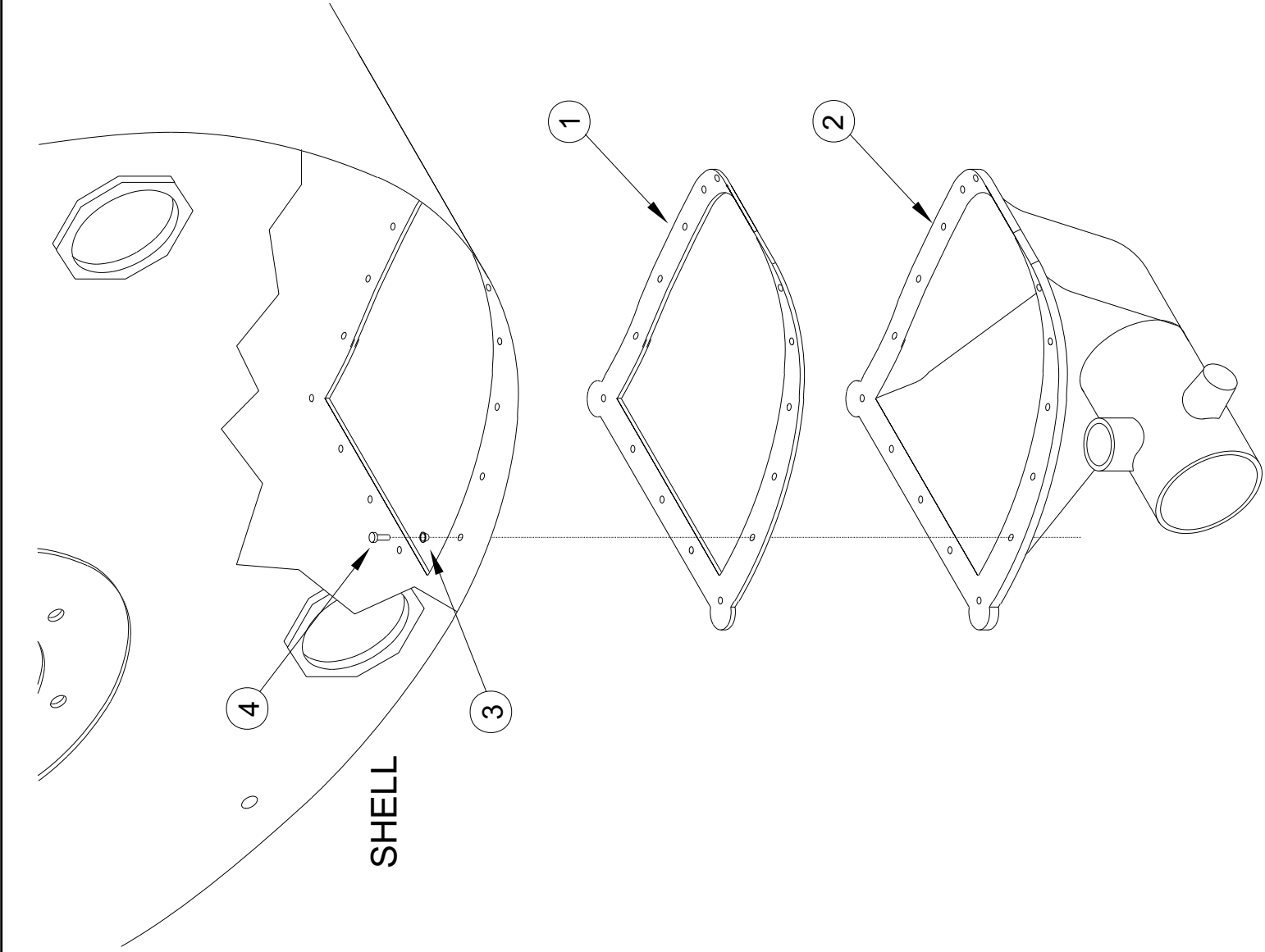

Parts List—Drain Sump Installation

Find the correct assembly first, then find the needed components. The item letters (A, B, C, etc.) assigned to assemblies are referred to in the "Used In" column to identify which components belong to an assembly. The item numbers (1, 2, 3, etc.) assigned to components relate the parts list to the illustration.

Used In	Item	Part Number	Description	Comments
			-----COMPONENTS-----	
all	1	02 03366A	DRAIN SUMP GASKET 1/8"EPDM	
all	2	02 03332A	BODY=SUMP-1608 GLASTIC	
all	3	24G018N	ROLLED WASH:194ID NYLTITE 10W	
all	4	15P050	PHDCUT-F PANHD 10-32X3/4 SS410	

Drain Valve Installation
3010 & 3015 G5E, G5X, CGE
30015 & 30022 C4E

BMP020057/2004055V
(Sheet 1 of 2)



Pellerin Milnor Corporation
P. O. Box 400, Kenner, LA 70063-0400

Litho in U.S.A.

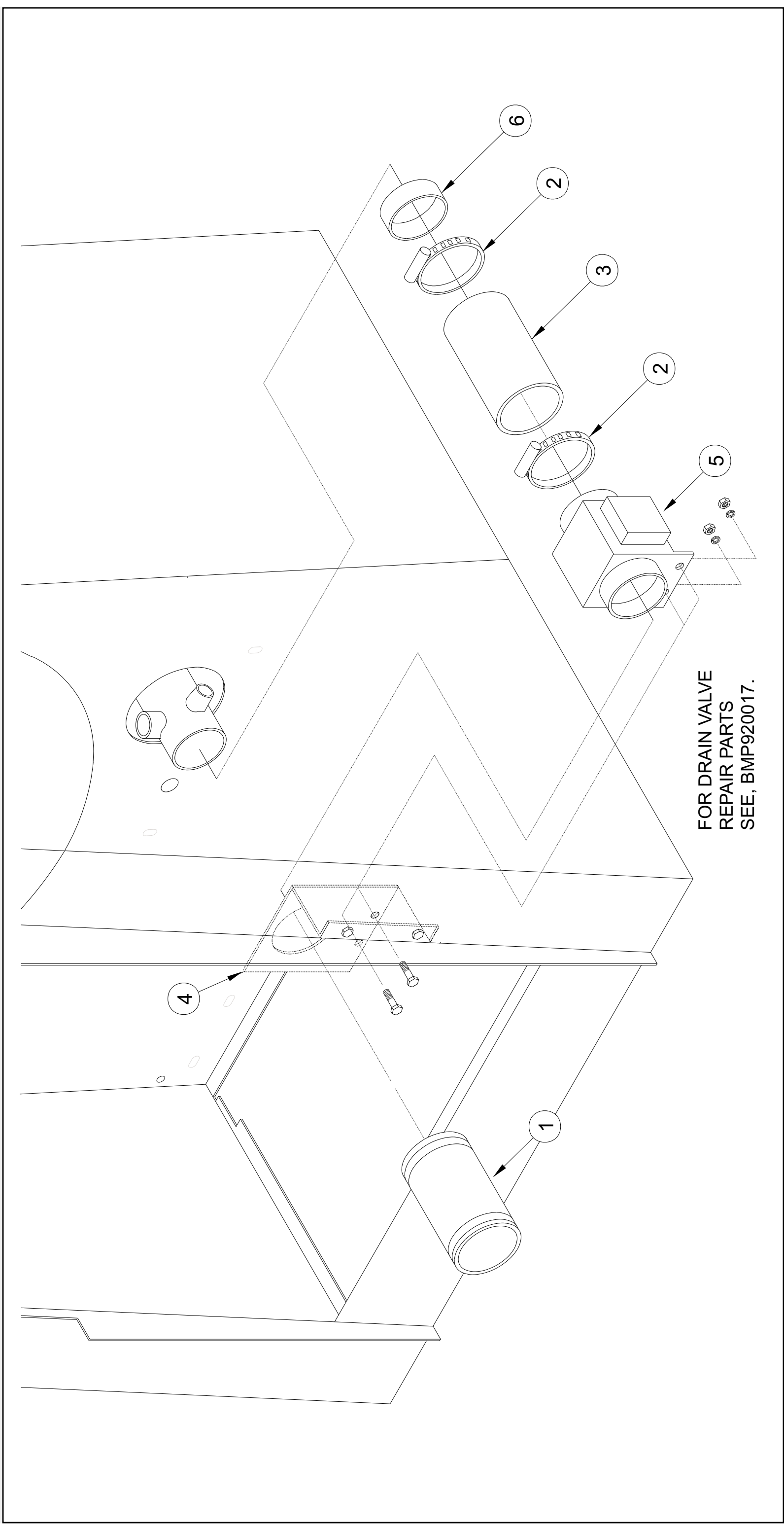



Pellerin Milnor Corporation
P. O. Box 400, Kenner, LA 70063-0400

Litho in U.S.A.

Parts List—Drain Valve Installation

Find the correct assembly first, then find the needed components. The item letters (A, B, C, etc.) assigned to assemblies are referred to in the "Used In" column to identify which components belong to an assembly. The item numbers (1, 2, 3, etc.) assigned to components relate the parts list to the illustration.

Used In	Item	Part Number	Description	Comments
-----ASSEMBLIES-----				
	A	GDV30001	30" DRAINVALVE INSTALL	3015,3022C4E
	B	GDV30003	3010 SINGLE DRAIN TO REAR INST	3010,3015G5E,G5X,CGE
-----COMPONENTS-----				
all	1	60B075	DFW56-33PMSP RUBB CONN.	
all	2	27A082	HOSECLAMP 2.5625-3.5CADSC#HS48	
all	3	60E303A07A	HOSE=3"ID X 7" LG.	
A	4	02 03412E	3015/22 DRAIN VALVE BRKT	
B	4	02 03412J	3010 DRAIN VALVE BRKT	
all	5	96D350A71	DRINVAL 3"N/O MTRDR240V 50/60C	
all	6	02 03412S	SLEEVE=DUMPVALVE HOSE	

3" Electric Drain Valve

BMP920017/2002044V
(Sheet 1 of 2)



Pellerin Milnor Corporation
P. O. Box 400, Kenner, LA 70063-0400

Litho in U.S.A.

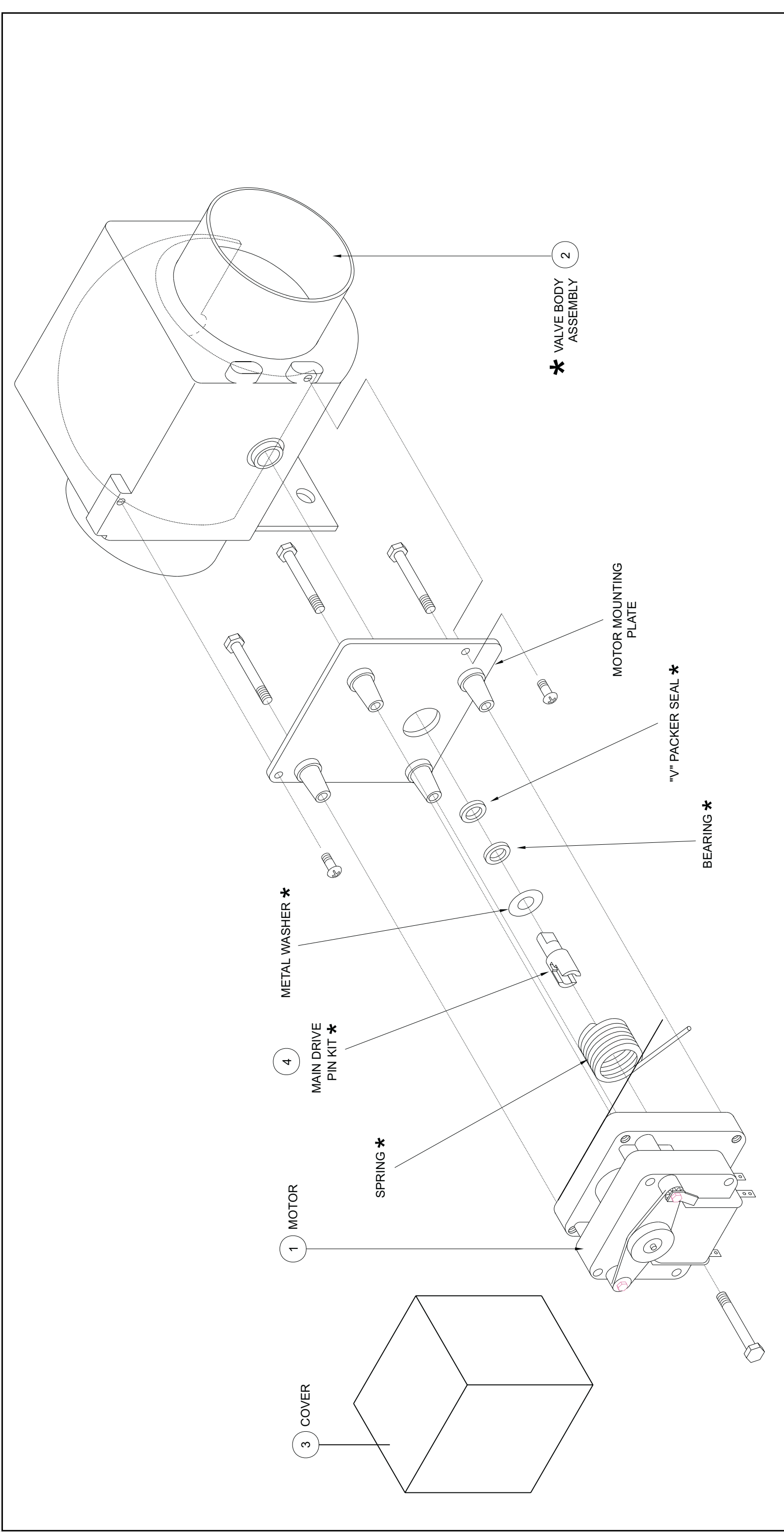



Pellerin Milnor Corporation
P. O. Box 400, Kenner, LA 70063-0400

Litho in U.S.A.

Parts List—3" Electric Drain Valve

Find the correct assembly first, then find the needed components. The item letters (A, B, C, etc.) assigned to assemblies are referred to in the "Used In" column to identify which components belong to an assembly. The item numbers (1, 2, 3, etc.) assigned to components relate the parts list to the illustration.

Used In	Item	Part Number	Description	Comments
-----ASSEMBLIES-----				
	A	96D350A37	DRINVAL 3"N/O MTRDR120V 50/60C	
	B	96D350A71	DRINVAL 3"N/O MTRDR240V 50/60C	
-----COMPONENTS-----				
A	1	96D35MTR37	120V 50/60CMTR FOR 3"DRAINVAL	
B	1	96D35MTR71	240V 50/60CMTR FOR 3"DRAINVAL	
all	2	96D35B0D	BODY & BALL FOR 3" DRAIN VALVE	
all	3	96D35C0V	MTRCOVER 2-PCFOR 3"DRAINVAL	
all	4	96D35PIN	DRIVE PIN KIT FOR 3" DRAIN VAL	

Section
Dimensional Drawings

8

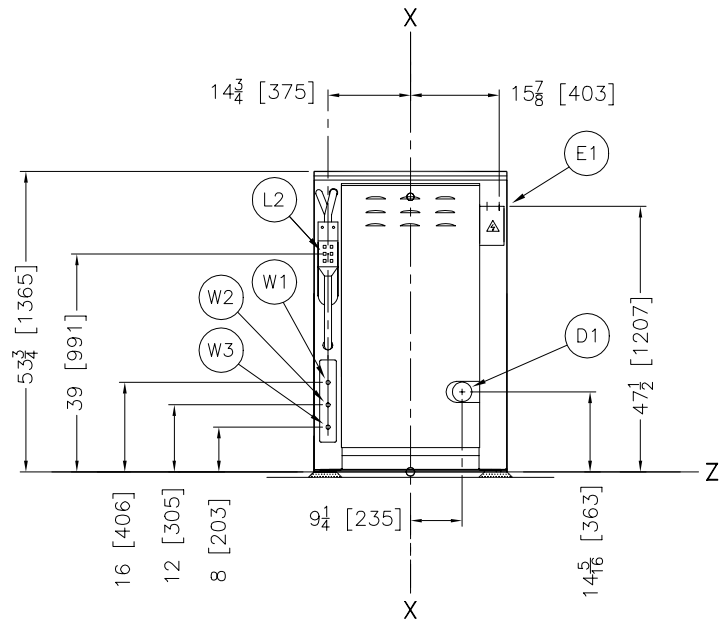
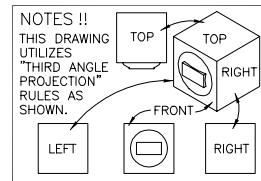
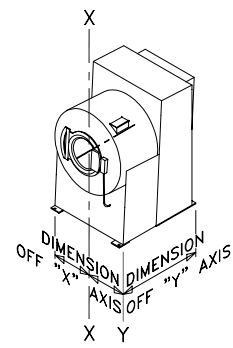

REAR VIEW

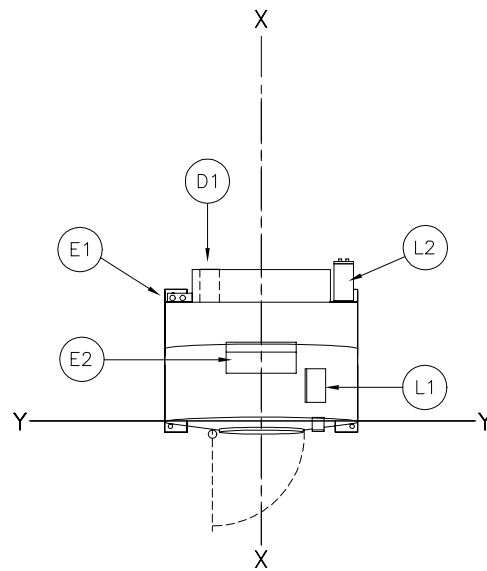

PLAN VIEW

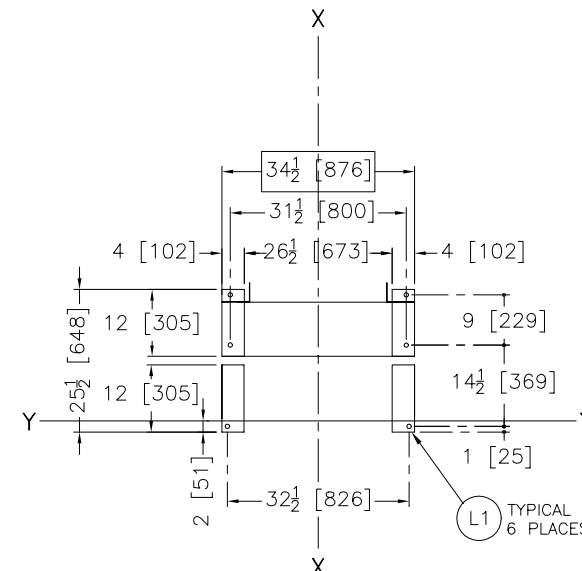

FOUNDATION VIEW

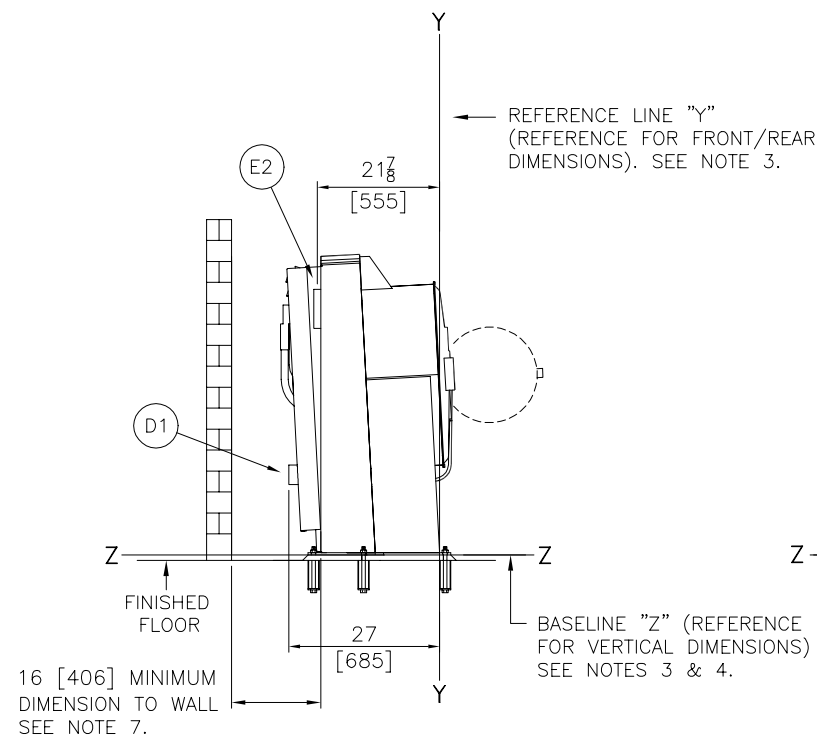

LEFT SIDE VIEW

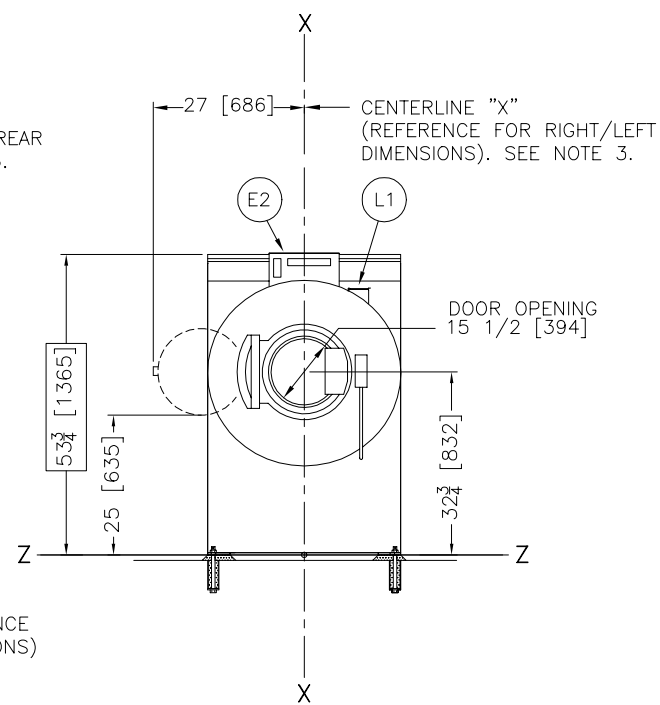

FRONT VIEW

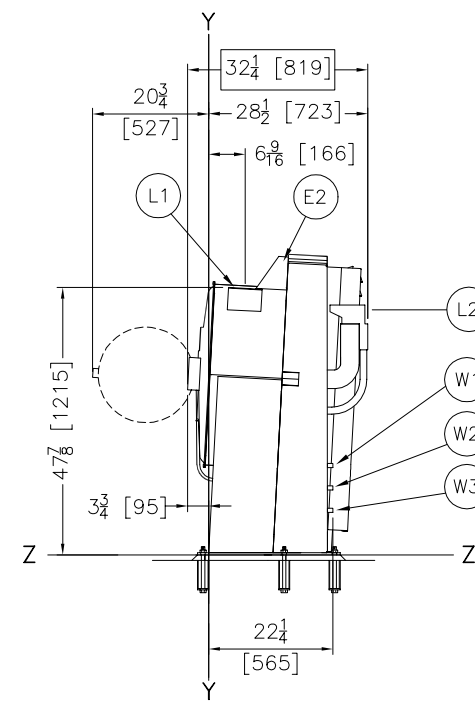

RIGHT SIDE VIEW

RECOMMENDED ANCHORING METHOD

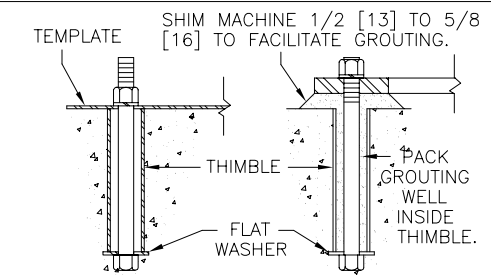

BOLTS AND THIMBLES ATTACHED TO TEMPLATE PRIOR TO POURING OF FOUNDATION.

... AFTER SETTING AND GROUTING

W3	COLD WATER INLET, 3/4" GARDEN HOSE, MALE THREAD.
W2	HOT WATER INLET, 3/4" GARDEN HOSE, MALE THREAD.
W1	HOT WATER (FLUSHING), 3/4" GARDEN HOSE, MALE THREAD.
L2	LIQUID SUPPLY INLETS, SEE NOTE 10.
L1	SOAP CHUTE
F1	ANCHOR BOLT HOLES, 13/16 [21] DIAMETER FOR 5/8" DIAMETER ANCHOR BOLTS. SEE NOTE 8.
E2	MICROPROCESSOR CONTROL PANEL
E1	ELECTRICAL CONNECTION
D1	DRAIN TO SEWER, 3" PIPE SOCKET JOINT.

ITEM LEGEND

- NOTES**
- LIQUID SUPPLY INLET STANDARD, WITH THREE SETS OF SIX FITTINGS, ONE SET OF 3/8" FITTINGS, ONE SET OF 1/2" FITTINGS, AND ONE SET OF PLUGS WHICH ARE SHIPPED ON MACHINE.
 - DO NOT PRE-PIPE ANY CLOSER THAN 60 [1524].
 - ANCHOR BOLTS ARE REQUIRED FOR ALL SIX (6) MOUNTING BOLT HOLES OR THE WARRANTY WILL BE DECLARED INVALID. ALL MOUNTING HOLES ARE 13/16 [21] DIA. AND USE 5/8 [16] DIA. BOLTS. GROUT UNDER ALL BASE PLATES.
 - ABSOLUTE MINIMUM DISTANCE TO WALL IS 16 [406], 24 [609] TO 36 [914] RECOMMENDED FOR SERVICING.
 - AS OF THIS WRITING, THE MINIMUM CLEARANCE REQUIRED BY U.S. NATIONAL ELECTRIC CODES, FROM ELECTRIC BOX TO ANY OBJECT IS:
 - 36 [914] IF OBJECT IS AN UNGROUNDED (INSULATED) WALL.
 - 42 [1067] IF OBJECT IS A GROUNDED WALL (ie. BARE CONCRETE, BRICK, ETC.)
 - 48 [1219] IF OBJECT IS ANY LIVE PART.
 CHECK LOCAL ELECTRIC CODES FOR FURTHER RESTRICTIONS.
 - CUSTOMER TO SUPPLY CIRCUIT BREAKER OR FUSED BRANCH CIRCUIT DISCONNECT (SAFETY) SWITCHES WITH LAG TYPE FUSES FROM POWER SOURCE TO MACHINE. A SEPARATE GROUND WIRE MUST BE CONNECTED FROM DISCONNECT TO EQUIPMENT.
 - BASELINE "Z" IS THE REFERENCE FOR ALL VERTICAL DIMENSIONS. ON MACHINES WITH FIXED BASE PADS, BASELINE "Z" CORRESPONDS TO THE BOTTOM OF THE BASE PAD. ON MACHINES WITH ADJUSTABLE FEET, BASELINE "Z" CORRESPONDS TO THE BOTTOM OF THE FEET WHEN ADJUSTED SO THAT THE MACHINE IS AT ITS MINIMUM ACCEPTABLE HEIGHT. ON TRAVELING SHUTTLES, BASELINE "Z" CORRESPONDS TO THE BOTTOM OF THE BOTTOM RAIL. THE DISTANCE BETWEEN BASELINE "Z" AND THE FINISHED FLOOR WILL VARY AS REQUIRED TO ENSURE BASELINE "Z" IS HORIZONTAL AND ANY INTERFACING MACHINES REQUIRING GROUT ARE SET ON A MINIMUM 1" [25] THICK GROUT BED.
 - USE REFERENCE LINES "X", "Y", AND "Z" TO LOCATE ALL SERVICE CONNECTIONS.
 - NUMBERS IN BRACKETS [] DENOTE DIMENSIONS IN MILLIMETERS.
 - ALL DIMENSIONS SHOWN ARE APPROXIMATE, SUBJECT TO NORMAL MANUFACTURING TOLERANCES, AND TO OCCASIONAL CHANGES WITHOUT NOTICE THROUGH REDESIGN AND/OR RELOCATION OF COMPONENTS, ETC. DO NOT USE FOR CONSTRUCTION UNLESS CERTIFIED, AND IN NO EVENT PRE-PIPE CLOSER THAN FIVE FEET FROM MACHINE. FACTORY MUST BE CONSULTED FOR DIMENSIONS IF MACHINE IS TO BE MOVED THROUGH NARROW OR LOW CORRIDORS OR OPENINGS.

ATTENTION

MOST REGULATORY AUTHORITIES (INCLUDING OSHA IN THE USA) HOLD THE OWNER/USER ULTIMATELY RESPONSIBLE TO MAINTAIN A SAFE WORKING ENVIRONMENT. ACCORDINGLY, THE OWNER/USER MUST RECOGNIZE ALL FORESEEABLE SAFETY HAZARDS, FURNISH SAFETY INSTRUCTIONS AND GUIDANCE TO ALL PERSONNEL WHO MAY COME IN CONTACT WITH THE INSTALLATION, AND PROVIDE ALL NECESSARY ADDITIONAL SAFETY GUARDS, FENCES, RESTRAINTS, DEVICES, ETC., NOT FURNISHED BY THE EQUIPMENT MANUFACTURER OR VENDOR.

ATTENTION

THE FLOOR AND/OR OTHER SUPPORT COMPONENTS MUST HAVE SUFFICIENT STRENGTH (AND RIGIDITY WITH DUE CONSIDERATION FOR NATURAL OR RESONANT FREQUENCY THEREOF) TO WITHSTAND THE FULLY LOADED WEIGHT OF THE MACHINE INCLUDING THE GOODS, THE WATER, AND ANY REPEATED SINUSOIDAL (ROTATING) FORCES GENERATED DURING ITS OPERATION. WRITE THE FACTORY FOR ADDITIONAL MACHINE DATA FOR USE BY A COMPETENT SOIL AND/OR STRUCTURAL ENGINEER.

3010G5E, G5X

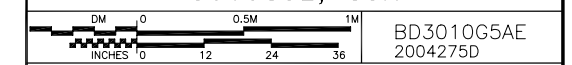

BD3010G5AE
2004275D

MILNOR PELLERIN MILNOR CORPORATION
P.O. Box 400 Kenner, LA 70063, USA, Phone 504/467-9591, FAX 504/469-1849, Telex IIT 460124/PELM UI, Cable PELMILNOR

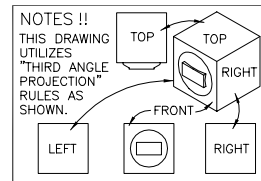
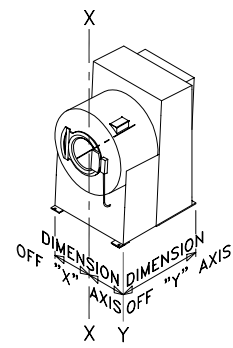

NOTES !!
THIS DRAWING UTILIZES "THIRD ANGLE PROJECTION" RULES AS SHOWN.

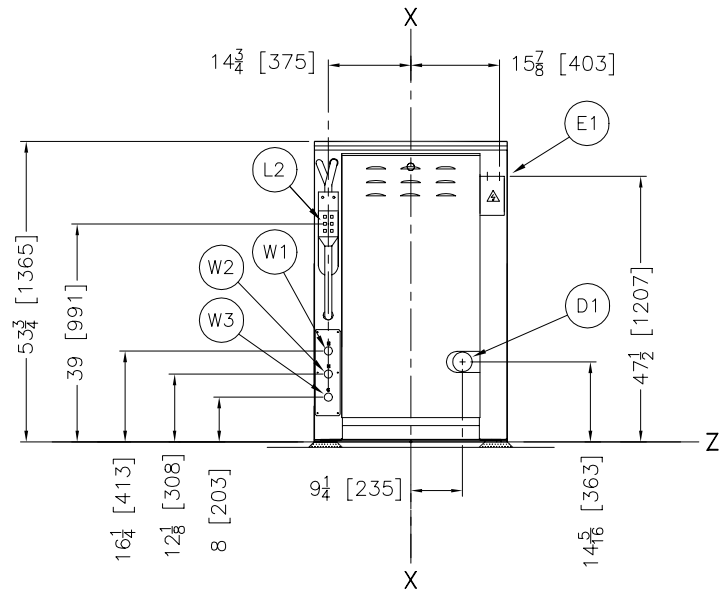

REAR VIEW

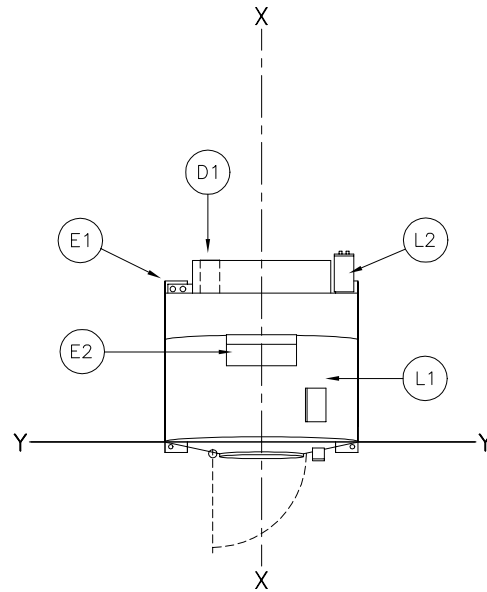

PLAN VIEW

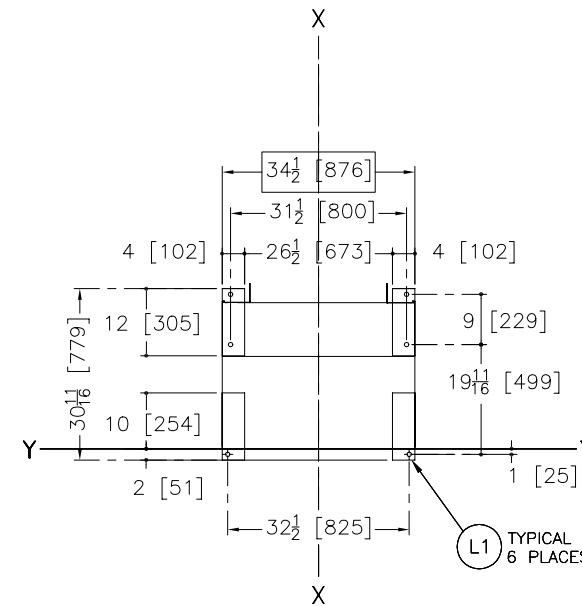

FOUNDATION VIEW

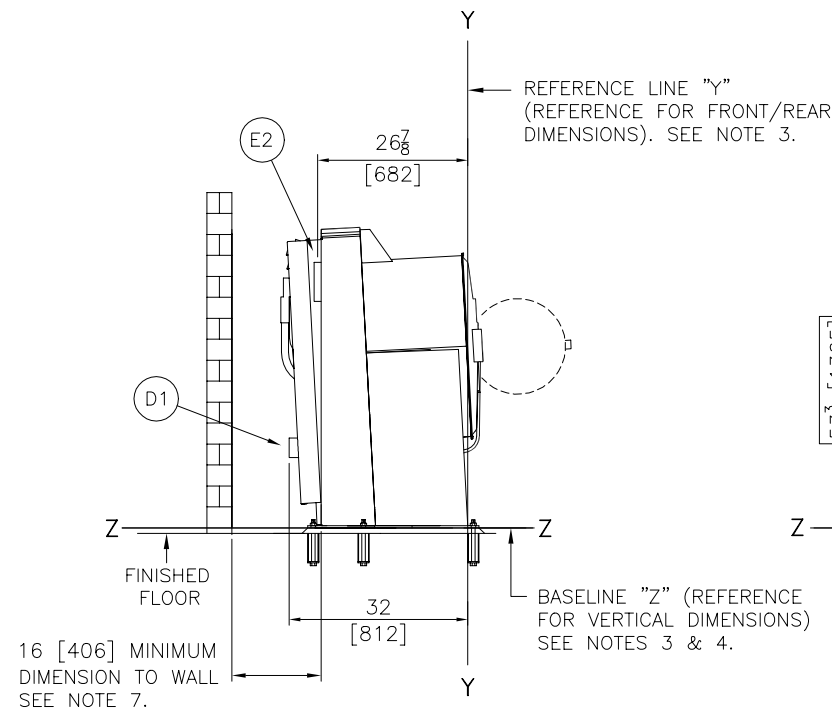

LEFT SIDE VIEW

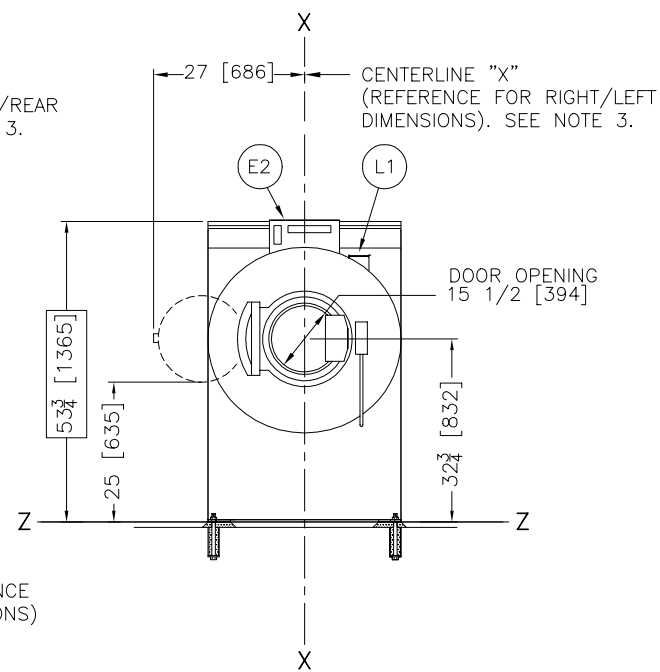

FRONT VIEW

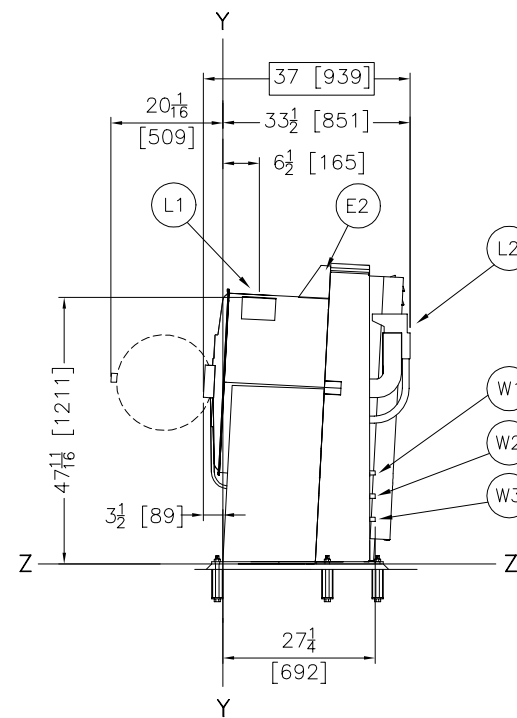

RIGHT SIDE VIEW

RECOMMENDED ANCHORING METHOD

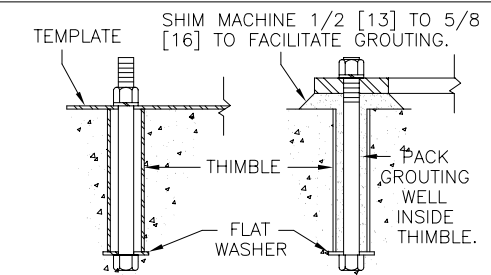

BOLTS AND THIMBLES ATTACHED TO TEMPLATE PRIOR TO POURING OF FOUNDATION. ... AFTER SETTING AND GROUTING

W3	COLD WATER INLET, 3/4" GARDEN HOSE, MALE THREAD.
W2	HOT WATER INLET, 3/4" GARDEN HOSE, MALE THREAD.
W1	HOT WATER (FLUSHING), 3/4" GARDEN HOSE, MALE THREAD.
L2	LIQUID SUPPLY INLETS, SEE NOTE 10.
L1	SOAP CHUTE
F1	ANCHOR BOLT HOLES, 13/16 [21] DIAMETER FOR 5/8" DIAMETER ANCHOR BOLTS. SEE NOTE 8.
E2	MICROPROCESSOR CONTROL PANEL
E1	ELECTRICAL CONNECTION
D1	DRAIN TO SEWER, 3" PIPE SOCKET JOINT.

ITEM	LEGEND
------	--------

- NOTES**
- LIQUID SUPPLY INLET STANDARD, WITH THREE SETS OF SIX FITTINGS, ONE SET OF 3/8" FITTINGS, ONE SET OF 1/2" FITTINGS, AND ONE SET OF PLUGS WHICH ARE SHIPPED ON MACHINE.
 - DO NOT PRE-PIPE ANY CLOSER THAN 60 [1524].
 - ANCHOR BOLTS ARE REQUIRED FOR ALL SIX (6) MOUNTING BOLT HOLES OR THE WARRANTY WILL BE DECLARED INVALID. ALL MOUNTING HOLES ARE 13/16 [21] DIA. AND USE 5/8 [16] DIA. BOLTS. GROUT UNDER ALL BASE PLATES.
 - ABSOLUTE MINIMUM DISTANCE TO WALL IS 16 [406], 24 [609] TO 36 [914] RECOMMENDED FOR SERVICING.
 - AS OF THIS WRITING, THE MINIMUM CLEARANCE REQUIRED BY U.S. NATIONAL ELECTRIC CODES, FROM ELECTRIC BOX TO ANY OBJECT IS:
 - 36 [914] IF OBJECT IS AN UNGROUNDED (INSULATED) WALL.
 - 42 [1067] IF OBJECT IS A GROUNDED WALL (ie. BARE CONCRETE, BRICK, ETC.)
 - 48 [1219] IF OBJECT IS ANY LIVE PART.
 CHECK LOCAL ELECTRIC CODES FOR FURTHER RESTRICTIONS.
 - CUSTOMER TO SUPPLY CIRCUIT BREAKER OR FUSED BRANCH CIRCUIT DISCONNECT (SAFETY) SWITCHES WITH LAG TYPE FUSES FROM POWER SOURCE TO MACHINE. A SEPARATE GROUND WIRE MUST BE CONNECTED FROM DISCONNECT TO EQUIPMENT.
 - BASELINE "Z" IS THE REFERENCE FOR ALL VERTICAL DIMENSIONS. ON MACHINES WITH FIXED BASE PADS, BASELINE "Z" CORRESPONDS TO THE BOTTOM OF THE BASE PAD. ON MACHINES WITH ADJUSTABLE FEET, BASELINE "Z" CORRESPONDS TO THE BOTTOM OF THE FEET WHEN ADJUSTED SO THAT THE MACHINE IS AT ITS MINIMUM ACCEPTABLE HEIGHT. ON TRAVELING SHUTTLES, BASELINE "Z" CORRESPONDS TO THE BOTTOM OF THE BOTTOM RAIL. THE DISTANCE BETWEEN BASELINE "Z" AND THE FINISHED FLOOR WILL VARY AS REQUIRED TO ENSURE BASELINE "Z" IS HORIZONTAL AND ANY INTERFACING MACHINES REQUIRING GROUT ARE SET ON A MINIMUM 1 [25] THICK GROUT BED.
 - USE REFERENCE LINES "X", "Y", AND "Z" TO LOCATE ALL SERVICE CONNECTIONS.
 - NUMBERS IN BRACKETS [] DENOTE DIMENSIONS IN MILLIMETERS.
 - ALL DIMENSIONS SHOWN ARE APPROXIMATE, SUBJECT TO NORMAL MANUFACTURING TOLERANCES, AND TO OCCASIONAL CHANGES WITHOUT NOTICE THROUGH REDESIGN AND/OR RELOCATION OF COMPONENTS, ETC. DO NOT USE FOR CONSTRUCTION UNLESS CERTIFIED, AND IN NO EVENT PRE-PIPE CLOSER THAN FIVE FEET FROM MACHINE. FACTORY MUST BE CONSULTED FOR DIMENSIONS IF MACHINE IS TO BE MOVED THROUGH NARROW OR LOW CORRIDORS OR OPENINGS.
- ATTENTION**
MOST REGULATORY AUTHORITIES (INCLUDING OSHA IN THE USA) HOLD THE OWNER/USER ULTIMATELY RESPONSIBLE TO MAINTAIN A SAFE WORKING ENVIRONMENT. ACCORDINGLY, THE OWNER/USER MUST RECOGNIZE ALL FORESEEABLE SAFETY HAZARDS, FURNISH SAFETY INSTRUCTIONS AND GUIDANCE TO ALL PERSONNEL WHO MAY COME IN CONTACT WITH THE INSTALLATION, AND PROVIDE ALL NECESSARY ADDITIONAL SAFETY GUARDS, FENCES, RESTRAINTS, DEVICES, ETC., NOT FURNISHED BY THE EQUIPMENT MANUFACTURER OR VENDOR.
- ATTENTION**
THE FLOOR AND/OR OTHER SUPPORT COMPONENTS MUST HAVE SUFFICIENT STRENGTH (AND RIGIDITY WITH DUE CONSIDERATION FOR NATURAL OR RESONANT FREQUENCY THEREOF) TO WITHSTAND THE FULLY LOADED WEIGHT OF THE MACHINE INCLUDING THE GOODS, THE WATER, AND ANY REPEATED SINUSOIDAL (ROTATING) FORCES GENERATED DURING ITS OPERATION. WRITE THE FACTORY FOR ADDITIONAL MACHINE DATA FOR USE BY A COMPETENT SOIL AND/OR STRUCTURAL ENGINEER.

3015G5E,G5X

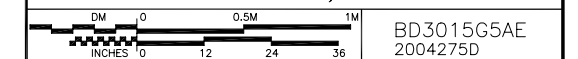

BD3015G5AE
2004275D
MILNOR PELLERIN MILNOR CORPORATION
P.O. Box 400 Kenner, LA 70063, USA, Phone 504/467-9591,
FAX 504/469-1849, Telex IIT 460124/PELM U, Cable PELMILNOR