

Manual Number: MCWMEA01  
Edition (ECN): 2024123A



# Installation, Parts, and Service

## MWF100J7, MWF100Z7





## Contents

1 General Service and Safety Related Components .....	6
Limited Standard Warranty .....	7
1.1 How to Get the Necessary Repair Components .....	8
1.2 Trademarks .....	8
1.3 Safety — Suspended Washer Extractors .....	9
1.3.1 Safety Alert Messages—Internal Electrical and Mechanical Hazards .....	9
1.3.2 Safety Alert Messages—Cylinder and Processing Hazards .....	9
1.3.3 Safety Alert Messages—Unsafe Conditions .....	11
1.3.3.1 Damage and Malfunction Hazards .....	11
1.3.3.1.1 Hazards Resulting from Inoperative Safety Devices .....	11
1.3.3.1.2 Hazards Resulting from Damaged Mechanical Devices .....	11
1.3.3.2 Careless Use Hazards .....	12
1.3.3.2.1 Careless Operation Hazards—Vital Information for Operator Personnel (see also operator hazards throughout manual) .....	12
1.3.3.2.2 Careless Servicing Hazards—Vital Information for Service Personnel (see also service hazards throughout manuals) .....	12
1.4 Installation Tag Guidelines .....	13
Safety Placards and Locations MWF100J7, MWF100Z7, MWF125J7, MWF125Z7 .....	18
Safety Placards and Locations—ISO MWF100J7, MWF100Z7, MWF125J7, MWF125Z7 .....	20
Guards & Covers MWF100J7, MWF100Z7, MWF125J7, MWF125Z7 .....	22
Shipping Brackets MWF100J7, MWF100Z7, MWF100C7, MWF100Y7, MWF125J7, MWF125Z7, MWF125C7, MWF125Y7 .....	24
1.5 Torque Requirements for Fasteners .....	26
1.5.1 Torque Values .....	26
1.5.1.1 Fasteners Made of Carbon Steel .....	26
1.5.1.1.1 Without a Threadlocker .....	26
1.5.1.1.2 With a Threadlocker .....	28
1.5.1.2 Stainless Steel Fasteners .....	30
1.5.2 Preparation .....	31
1.5.3 How to Apply a Threadlocker .....	32
1.5.3.1 Blind Holes .....	32
1.5.3.2 Through Holes .....	32
2 Important Installation Precautions .....	34
2.1 External Fuse/Breaker, Wiring, and Disconnect Requirements .....	34
2.1.1 Fuse or Circuit Breaker Size .....	34
• If a fuse is used .....	34
• If a standard circuit breaker is used .....	34
• If an inverse time circuit breaker is used .....	34
2.1.2 Wire Size .....	34
2.1.3 Ground .....	35
2.1.4 Disconnect Switch for Lockout/Tagout .....	35
2.1.5 Using GFCI (Ground Fault Circuit Interrupter) Device .....	35
2.2 Vital Information About the Forces Imparted to Supporting Structures by Launder- ing Machines .....	35
2.2.1 Disclaimer of Responsibility .....	36
2.2.2 Major Design Considerations .....	36

2.2.3 Primary Information Sources .....	37
2.3 Prevent Damage from Chemical Supplies and Chemical Systems .....	37
2.3.1 How Chemical Supplies Can Cause Damage.....	38
• Dangerous Chemical Supplies and Wash Formulas.....	38
• Incorrect Configuration or Connection of Equipment .....	38
2.3.2 Equipment and Procedures That Can Prevent Damage.....	40
• Use the chemical manifold supplied. ....	40
• Close the line.....	41
• Do not let a vacuum occur.....	41
• Flush the chemical tube with water.....	41
• Put the chemical tube fully below the inlet.....	41
• Prevent leaks. ....	41
3 Installation Procedures .....	42
3.1 Handling a Washer-extractor from Delivery to Final Location .....	42
3.1.1 Notices.....	42
• Qualified Personnel Only.....	42
• Disclaimer .....	42
• Other Tasks .....	42
3.1.2 Facility Prerequisites .....	43
3.1.3 Rigger Precautions.....	43
3.1.4 Technician Precautions.....	45
• Can the Door(s) Be Opened Before Utilities are Connected? .....	47
3.2 Connection Precautions for Washer-extractors .....	47
3.2.1 Notices.....	48
• Machine Must Be Anchored .....	48
3.2.2 Utility Requirements and Related Information .....	48
3.2.3 Plumber Precautions.....	49
3.2.4 Electrician Precautions .....	50
3.2.5 Chemical Supplier Precautions.....	51
4 Drive Assemblies.....	52
Drive Components MWF100J7, MWF100C7, MWF100Y7.....	53
Cylinder and Bearing Installation 4840F, MWF100, MWF125 .....	54
Bearing Assembly 4840F, MWF100, MWF125 .....	58
Air Injection Components .....	64
5 Suspension.....	66
Suspension MWF100J7, MWF100Z7, MWF100C7, MWF100Y7; MWF125J7, MWF125Z7, MWF125C7, MWF125Y7.....	68
6 Door Assemblies .....	70
Manual Door MWF100C7, MWF100Y7, MWF100J7, MWF100Z7; MWF125C7, MWF125Y7, MWF125J7, MWF125Z7.....	72
Door Latch .....	78
Door Latch .....	79
7 Chemical Supply .....	80
Soap Chute MWF100C7, MWF100Y7, MWF100J7, MWF100Z7; MWF125C7, MWF125Y7, MWF125J7, MWF125Z7.....	82
Peristaltic Chemical Inlets MWF100C7, MWF100Y7, MWF100J7, MWF100Z7; MWF125C7, MWF125Y7, MWF125J7, MWF125Z7 .....	84
8 Water and Drain.....	86



Water and Steam Schematic and Components MWF100J7, MWF100Z7, MWF100C7, MWF100Y7; MWF125J7, MWF125Z7, MWF125C7, MWF125Y7 .....	88
Water Inlet Components and Installation MWF100J7, MWF100Z7, MWF100C7, MWF100Y7; MWF125J7, MWF125Z7, MWF125C7, MWF125Y7 .....	90
Steam MWF100C7/Y7, MWF100 J7/Z7, MWF125C7/Y7, MWF125J/Z7 .....	92
Drain Valve to Rear MWF100J7,MWF100Z7; MWF125J7, MWF125Z7 .....	94
Drain Valve to Bottom MWF63C/Y, MWF77C/Y, MWF100C/Y, MWF125C/7- Standard; MWF63J/ Z, MWF77J/Z, MWF100J/Z, MWF125J/Z - Optional.....	96
9 Pneumatic Assemblies.....	98
Pneumatic Schematic MWF100J7, MWF100Z7 .....	99
10 Control and Sensing .....	102
Water Level & Temperature Sensor MWF45J8/Z8, MWF63J7/Z7, MWF77J7/Z7, MWF100J7/ Z7, MWF125J7/Z7; MWF45C8/Y8, MWF63C7/Y7, MWF77C7/Y7, MWF100C7/Y7, MWF125C7/Y7 .....	103
11 Dimensional Drawings .....	105
BDMWF100JZAE/2022276 — MWF100J7, MWF100Z7 .....	107
BDMWF100JZAB/2023404D — MWF100J7, MWF100Z7 (Options) .....	108

## Figures

Figure 1	Left Side View .....	24
Figure 2	The Bolts in Milnor® Equipment.....	26
Figure 3	Apply Threadlocker in a Blind Hole.....	32
Figure 4	Apply Threadlocker in a Through Hole.....	33
Figure 5	Use heat for disassembly of fasteners with threadlocker.....	33
Figure 6	How Rotating Forces Act On the Foundation .....	37
Figure 7	Incorrect Configurations That Let the Chemical Supply Go In the Ma- chine by a Siphon.....	39
Figure 8	Incorrect Configurations That Let the Chemical Supply Go In the Ma- chine by Gravity.....	40
Figure 9	Examples of Manifolds for Chemical Tubes. Your equipment can look different.....	40
Figure 10	A Configuration that Prevents Flow in the Machine When the Pump is Off (if the chemical tube and tank have no pressure) .....	41
Figure 11	Cross section view .....	54
Figure 12	Detailed views.....	55
Figure 13	Shell plugs.....	56
Figure 14	Air Flow in the Bearing Housing.....	65
Figure 15	Suspension Components .....	68
Figure 16	Installation, Manual Door .....	72
Figure 17	Adjust Door Position .....	73
Figure 18	Adjust Door Position .....	74
Figure 19	Door Components .....	75
Figure 20	Door Components, Detail Views .....	76
Figure 21	Door Latch .....	79
Figure 22	Soap Chute Components and Installation.....	82
Figure 23	Schematic Key .....	99
Figure 24	Enlarged View A.....	99

Figure 25 Enlarged View B.....100  
 Figure 26 Pneumatic Schematic Descriptions and Notes.....100

**Tables**

Table 1 Trademarks .....8  
 Table 2 Parts List—Safety Placards and Locations MWF100J7, MWF100Z7, MWF125J7, MWF125Z7.....19  
 Table 3 Parts List—Safety Placards and Locations—ISO MWF100J7, MWF100Z7, MWF125J7, MWF125Z7 .....20  
 Table 4 Parts List—Guards & Covers MWF100J7, MWF100Z7, MWF125J7, MWF125Z7 .....22  
 Table 5 Parts List—Shipping Brackets MWF100J7, MWF100Z7, MWF100C7, MWF100Y7, MWF125J7, MWF125Z7, MWF125C7, MWF125Y7 .....25  
 Table 6 Torque Values for Standard Fasteners with Maximum 5/16-inch Diameters and No Lubricant .....26  
 Table 7 Torque Values for Standard Fasteners Larger Than 5/16-inch Diameters and No Lubricant .....27  
 Table 8 Torque Values for Plated Fasteners with Maximum 5/16-inch Diameters and No Lubricant .....27  
 Table 9 Torque Values for Plated Fasteners Larger Than 5/16-inch Diameters and No Lubricant .....28  
 Table 10 Threadlocker by the Diameter of the Bolt (see below Note ) .....28  
 Table 11 Torque Values if You Apply LocTite 222 .....29  
 Table 12 Torque Values if You Apply LocTite 242 .....29  
 Table 13 Torque Values if You Apply LocTite 262 .....29  
 Table 14 Torque Values if You Apply LocTite 272 (High-Temperature) .....29  
 Table 15 Torque Values if You Apply LocTite 277 .....30  
 Table 16 Torque Values for Stainless Steel Fasteners 5/16-inch and Smaller .....30  
 Table 17 Torque Values for Stainless Steel Fasteners Larger Than 5/16-inch .....31  
 Table 18 Parts List—Drive Components MWF100J7, MWF100C7, MWF100Y7.....53  
 Table 19 Cylinder and Bearing Installation 4840F, MWF100, MWF125 .....56  
 Table 20 Bearing Assembly 4840F, MWF100, MWF125 .....61  
 Table 21 Parts List—Air Injection Components .....65  
 Table 22 Parts List—Suspension MWF100J7, MWF100Z7, MWF100C7, MWF100Y7; MWF125J7, MWF125Z7, MWF125C7, MWF125Y7 .....69  
 Table 23 Parts List—Manual Door MWF100C7, MWF100Y7, MWF100J7, MWF100Z7; MWF125C7, MWF125Y7, MWF125J7, MWF125Z7 .....77  
 Table 24 Parts List—Door Latch .....78  
 Table 25 Parts List—Door Latch .....79  
 Table 26 Parts List—Soap Chute MWF100C7, MWF100Y7, MWF100J7, MWF100Z7; MWF125C7, MWF125Y7, MWF125J7, MWF125Z7 .....83  
 Table 27 Parts List—Peristaltic Chemical Inlets MWF100C7, MWF100Y7, MWF100J7, MWF100Z7; MWF125C7, MWF125Y7, MWF125J7, MWF125Z7 .....85  
 Table 28 Parts List—Water and Steam Schematic and Components MWF100J7, MWF100Z7, MWF100C7, MWF100Y7; MWF125J7, MWF125Z7, MWF125C7, MWF125Y7 .....89  
 Table 29 Parts List—Water Inlet Components and Installation MWF100J7, MWF100Z7, MWF100C7, MWF100Y7; MWF125J7, MWF125Z7, MWF125C7, MWF125Y7.....91  
 Table 30 Parts List—Steam MWF100C7/Y7, MWF100 J7/Z7, MWF125C7/Y7, MWF125J/Z7.....92

Table 31	Parts List—Drain Valve to Rear MWF100J7,MWF100Z7; MWF125J7, MWF125Z7.....	94
Table 32	Parts List—Drain Valve to Bottom MWF63C/Y, MWF77C/Y, MWF100C/Y, MWF125C/7- Standard; MWF63J/Z, MWF77J/Z, MWF100J/Z, MWF125J/Z - Optional .....	97
Table 33	Parts List—Pneumatic Schematic MWF100J7, MWF100Z7 .....	101
Table 34	Parts List—Water Level & Temperature Sensor MWF45J8/Z8, MWF63J7/Z7, MWF77J7/Z7, MWF100J7/Z7, MWF125J7/Z7; MWF45C8/Y8, MWF63C7/Y7, MWF77C7/Y7, MWF100C7/Y7, MWF125C7/Y7 .....	103

# 1 General Service and Safety Related Components

BMP720097 / 19036

BRUUM01.1 0000229985 C.3 D.6 12/5/19, 11:43 AM Released

## **PELLERIN MILNOR CORPORATION LIMITED STANDARD WARRANTY**

We warrant to the original purchaser that MILNOR machines including electronic hardware/software (hereafter referred to as "equipment"), will be free from defects in material and workmanship for a period of one year from the date of shipment (unless the time period is specifically extended for certain parts pursuant to a specific MILNOR published extended warranty) from our factory with no operating hour limitation. This warranty is contingent upon the equipment being installed, operated and serviced as specified in the operating manual supplied with the equipment, and operated under normal conditions by competent operators.

Providing we receive written notification of a warranted defect within 30 days of its discovery, we will—at our option—repair or replace the defective part or parts, EX Factory (labor and freight specifically NOT included). We retain the right to require inspection of the parts claimed defective in our factory prior to repairing or replacing same. We will not be responsible, or in any way liable, for unauthorized repairs or service to our equipment, and this warranty shall be void if the equipment is tampered with, modified, or abused, used for purposes not intended in the design and construction of the machine, or is repaired or altered in any way without MILNOR's written consent.

Parts damaged by exposure to weather, to aggressive water, or to chemical attack are not covered by this warranty. For parts which require routine replacement due to normal wear—such as gaskets, contact points, brake and clutch linings, belts, hoses, and similar parts—the warranty time period is 90 days.

We reserve the right to make changes in the design and/or construction of our equipment (including purchased components) without obligation to change any equipment previously supplied.

ANY SALE OR FURNISHING OF ANY EQUIPMENT BY MILNOR IS MADE ONLY UPON THE EXPRESS UNDERSTANDING THAT MILNOR MAKES NO EXPRESSED OR IMPLIED WARRANTIES OF MERCHANTABILITY OR FITNESS FOR ANY PARTICULAR USE OR PURPOSE OR ANY OTHER WARRANTY IMPLIED BY LAW INCLUDING BUT NOT LIMITED TO REDHIBITION. MILNOR WILL NOT BE RESPONSIBLE FOR ANY COSTS OR DAMAGES ACTUALLY INCURRED OR REQUIRED AS A RESULT OF: THE FAILURE OF ANY OTHER PERSON OR ENTITY TO PERFORM ITS RESPONSIBILITIES, FIRE OR OTHER HAZARD, ACCIDENT, IMPROPER STORAGE, MIS-USE, NEGLIGENCE, POWER OR ENVIRONMENTAL CONTROL MALFUNCTIONS, DAMAGE FROM LIQUIDS, OR ANY OTHER CAUSE BEYOND THE NORMAL RANGE OF USE. REGARDLESS OF HOW CAUSED, IN NO EVENT SHALL MILNOR BE LIABLE FOR SPECIAL, INDIRECT, PUNITIVE, LIQUIDATED, OR CONSEQUENTIAL COSTS OR DAMAGES, OR ANY COSTS OR DAMAGES WHATSOEVER WHICH EXCEED THE PRICE PAID TO MILNOR FOR THE EQUIPMENT IT SELLS OR FURNISHES.

THE PROVISIONS ON THIS PAGE REPRESENT THE ONLY WARRANTY FROM MILNOR AND NO OTHER WARRANTY OR CONDITIONS, STATUTORY OR OTHERWISE, SHALL BE IMPLIED.

WE NEITHER ASSUME, NOR AUTHORIZE ANY EMPLOYEE OR OTHER PERSON TO ASSUME FOR US, ANY OTHER RESPONSIBILITY AND/OR LIABILITY IN CONNECTION WITH THE SALE OR FURNISHING OF OUR EQUIPMENT TO ANY BUYER.

BMP720097/19036

## 1.1 How to Get the Necessary Repair Components

BNUUUM01.C01 0000250120 A.3 B.3 C.3 1/2/20, 2:14 PM Released

You can get components to repair your machine from the approved supplier where you got this machine. Your supplier will usually have the necessary components in stock. You can also get components from the Milnor® factory.

Tell the supplier the machine model and serial number and this data for each necessary component:

- The component number from this manual
- The component name if known
- The necessary quantity
- The necessary transportation requirements
- If the component is an electrical component, give the schematic number if known.
- If the component is a motor or an electrical control, give the nameplate data from the used component.

To write to the Milnor® factory:

Pellerin Milnor Corporation  
 Post Office Box 400  
 Kenner, LA 70063-0400  
 UNITED STATES

Telephone: 504-712-7775

Fax: 504-469-9777

Email: parts@milnor.com

## 1.2 Trademarks

BNUUUU02.R01 0000158093 C.3 G.2 F.2 7/20/23, 10:57 AM Released

These words are trademarks of Pellerin Milnor® Corporation and other entities:

**Table 1. Trademarks**

AutoSpot™	GreenFlex™	MilMetrix®	PulseFlow®
CBW®	GearTrace™	MilTouch™	RAM Command™
Drynet™	GreenTurn™	MilTouch-EX™	RecircONE®
E-P Express®	Hydro-cushion™	MilRAIL®	RinSave®
E-P OneTouch®	Mentor®	Miltrac™	SmoothCoil™

**Table 1 Trademarks (cont'd.)**

E-P Plus®	Mildata®	MilVision™	Staph Guard®
Gear Guardian®	Milnor®	PBW™	

BNWSUS08 / 21224

BNWSUS08 0000348933 C.3 5/26/21, 12:00 PM Released

## 1.3 Safety — Suspended Washer Extractors

BNWSUS08.C01 0000348932 A.2 C.3 5/26/21, 11:48 AM Released

### 1.3.1 Safety Alert Messages—Internal Electrical and Mechanical Hazards

BNWSUS01.C03 0000234965 A.2 A.4 C.3 1/2/20, 2:19 PM Released

The following are instructions about hazards inside the machine and in electrical enclosures.



**WARNING: Electrocution and Electrical Burn Hazards** — Contact with electric power can kill or seriously injure you. Electric power is present inside the cabinetry unless the main machine power disconnect is off.

- ▶ Do not unlock or open electric box doors.
- ▶ Do not remove guards, covers, or panels.
- ▶ Do not reach into the machine housing or frame.
- ▶ Keep yourself and others off of machine.
- ▶ Know the location of the main machine disconnect and use it in an emergency to remove all electric power from the machine.



**WARNING: Entangle and Crush Hazards** — Contact with moving components normally isolated by guards, covers, and panels, can entangle and crush your limbs. These components move automatically.

- ▶ Do not remove guards, covers, or panels.
- ▶ Do not reach into the machine housing or frame.
- ▶ Keep yourself and others off of machine.
- ▶ Know the location of all emergency stop switches, pull cords, and/or kick plates and use them in an emergency to stop machine motion.

### 1.3.2 Safety Alert Messages—Cylinder and Processing Hazards

BNWSUS03.C03 0000234973 A.2 A.3 C.3 1/2/20, 2:19 PM Released

The following are instructions about hazards related to the cylinder and laundering process.



**DANGER: Entangle and Sever Hazards** — Contact with goods being processed can cause the goods to wrap around your body or limbs and dismember you. The goods are normally isolated by the locked cylinder door.

- ▶ Do not attempt to open the door or reach into the cylinder until the cylinder is stopped.
- ▶ Do not touch goods inside or hanging partially outside the turning cylinder.
- ▶ Do not operate the machine with a malfunctioning door interlock.
- ▶ Open pocket machines only—Do not jog the cylinder and pull the goods at the same time.
- ▶ Open pocket machines only—Keep yourself and others clear of cylinder and goods during jogging operation.
- ▶ Do not operate the machine with malfunctioning two-hand manual controls.
- ▶ Know the location of all emergency stop switches, pull cords, and/or kick plates and use them in an emergency to stop machine motion.
- ▶ Know the location of the main machine disconnect and use it in an emergency to remove all electric power from the machine.



**WARNING: Crush Hazards** — Contact with the turning cylinder can crush your limbs. The cylinder will repel any object you try to stop it with, possibly causing the object to strike or stab you. The turning cylinder is normally isolated by the locked cylinder door.

- ▶ Do not attempt to open the door or reach into the cylinder until the cylinder is stopped.
- ▶ Do not place any object in the turning cylinder.
- ▶ Do not operate the machine with a malfunctioning door interlock.
- ▶ Open pocket machines only—Keep yourself and others clear of cylinder and goods during jogging operation.
- ▶ Do not operate the machine with malfunctioning two-hand manual controls.



**WARNING: Confined Space Hazards** — Confinement in the cylinder can kill or injure you. Hazards include but are not limited to panic, burns, poisoning, suffocation, heat prostration, biological contamination, electrocution, and crushing.

- ▶ Do not attempt unauthorized servicing, repairs, or modification.



**WARNING: Explosion and Fire Hazards** — Flammable substances can explode or ignite in the cylinder, drain trough, or sewer. The machine is designed for washing with water, not any other solvent. Processing can cause solvent-containing goods to give off flammable vapors.



- ▶ Do not use flammable solvents in processing.
- ▶ Do not process goods containing flammable substances. Consult with your local fire department/public safety office and all insurance providers.

### 1.3.3 Safety Alert Messages—Unsafe Conditions

BNWSUS04.C01 0000235002 A.2 A.3 C.3 12/10/20, 4:36 PM Released

#### 1.3.3.1 Damage and Malfunction Hazards

BNWSUS04.C02 0000235001 A.2 A.3 C.3 12/10/20, 4:36 PM Released

##### 1.3.3.1.1 Hazards Resulting from Inoperative Safety Devices

BNWSUS04.C03 0000235000 A.2 A.6 C.3 12/10/20, 4:36 PM Released



**DANGER: Entangle and Sever Hazards** — Cylinder door interlock— Operating the machine with a malfunctioning door interlock can permit opening the door when the cylinder is turning and/or starting the cycle with the door open, exposing the turning cylinder.

- ▶ Do not operate the machine with any evidence of damage or malfunction.



**WARNING: Multiple Hazards** — Operating the machine with an inoperative safety device can kill or injure personnel, damage or destroy the machine, damage property, and/or void the warranty.

- ▶ Do not tamper with or disable any safety device or operate the machine with a malfunctioning safety device. Request authorized service.



**WARNING: Electrocution and Electrical Burn Hazards** — Electric box doors—Operating the machine with any electric box door unlocked can expose high voltage conductors inside the box.

- ▶ Do not unlock or open electric box doors.



**WARNING: Entangle and Crush Hazards** — Guards, covers, and panels—Operating the machine with any guard, cover, or panel removed exposes moving components.

- ▶ Do not remove guards, covers, or panels.

##### 1.3.3.1.2 Hazards Resulting from Damaged Mechanical Devices

BNWSUS04.C04 0000234999 A.2 A.4 C.3 12/10/20, 4:36 PM Released



**WARNING: Multiple Hazards** — Operating a damaged machine can kill or injure personnel, further damage or destroy the machine, damage property, and/or void the warranty.

- ▶ Do not operate a damaged or malfunctioning machine. Request authorized service.



**WARNING: Explosion Hazards** — Cylinder—A damaged cylinder can rip apart during extraction, puncturing the shell and discharging metal fragments at high speed.

- ▶ Do not operate the machine with any evidence of damage or malfunction.



**WARNING: Explosion Hazards** — Clutch and speed switch (multiple motor machines)—A damaged clutch or speed switch can permit the low speed motor to engage during extract. This will over-speed the motor and pulleys and can cause them to rip apart, discharging metal fragments at high speed.

- ▶ Stop the machine immediately if any of these conditions occur: • abnormal whining sound during extract • skidding sound as extract ends • clutches remain engaged or re-engage during extract

### 1.3.3.2 Careless Use Hazards

BNWSUS04.C05 0000234998 A.2 A.3 C.3 12/10/20, 4:36 PM Released

#### 1.3.3.2.1 Careless Operation Hazards—Vital Information for Operator Personnel (see also operator hazards throughout manual)

BNWSUS04.C06 0000234997 A.2 A.4 C.3 12/10/20, 4:36 PM Released



**WARNING: Multiple Hazards** — Careless operator actions can kill or injure personnel, damage or destroy the machine, damage property, and/or void the warranty.

- ▶ Do not tamper with or disable any safety device or operate the machine with a malfunctioning safety device. Request authorized service.
- ▶ Do not operate a damaged or malfunctioning machine. Request authorized service.
- ▶ Do not attempt unauthorized servicing, repairs, or modification.
- ▶ Do not use the machine in any manner contrary to the factory instructions.
- ▶ Use the machine only for its customary and intended purpose.
- ▶ Understand the consequences of operating manually.

#### 1.3.3.2.2 Careless Servicing Hazards—Vital Information for Service Personnel (see also service hazards throughout manuals)

BNWSUS04.C07 0000234996 A.2 A.4 C.3 12/10/20, 4:36 PM Released

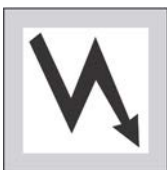

**WARNING: Electrocution and Electrical Burn Hazards** — Contact with electric power can kill or seriously injure you. Electric power is present inside the cabinetry unless the main machine power disconnect is off.

- ▶ Do not service the machine unless qualified and authorized. You must clearly understand the hazards and how to avoid them.

- ▶ Abide by the current OSHA lockout/tagout standard when lockout/tagout is called for in the service instructions. Outside the USA, abide by the OSHA standard in the absence of any other overriding standard.



**WARNING: Entangle and Crush Hazards** — Contact with moving components normally isolated by guards, covers, and panels, can entangle and crush your limbs. These components move automatically.

- ▶ Do not service the machine unless qualified and authorized. You must clearly understand the hazards and how to avoid them.
- ▶ Abide by the current OSHA lockout/tagout standard when lockout/tagout is called for in the service instructions. Outside the USA, abide by the OSHA standard in the absence of any other overriding standard.



**WARNING: Confined Space Hazards** — Confinement in the cylinder can kill or injure you. Hazards include but are not limited to panic, burns, poisoning, suffocation, heat prostration, biological contamination, electrocution, and crushing.

- ▶ Do not enter the cylinder until it has been thoroughly purged, flushed, drained, cooled, and immobilized.

BNWMAI01 / 2022363

BNWMAI01 0000204674 C.3 8/30/22, 3:24 PM Released

## 1.4 Installation Tag Guidelines

BNWMAI01.R01 0000204673 C.2 D.2 C.3 5/31/23, 9:24 AM Released

MWF27J8	MWF27Z8	MWF36J8	MWF36Z8
MWF45J8	MWF45Z8	MWF63C7	MWF63J7
MWF63Y7	MWF63Z7	MWF77C7	MWF77J7
MWF77Y7	MWF77Z7	MWF100C7	MWF100J7
MWF100Y7	MWF100Z7	MWF125C7	MWF125J7
MWF125Y7	MWF125Z7		



**NOTICE:** This information may apply to models in addition to those listed above. It applies to paper tags. It does not apply to the vinyl or metal safety placards, which must remain permanently affixed to the machine and replaced if no longer readable.

Paper tags on the machine provide installation guidelines and precautions. The tags can be tie-on or adhesive. You can remove tie-on tags and white, adhesive tags after installation. Yellow adhesive tags must remain on the machine.

The following entries explain the installation tags. Each entry includes: 1) the tag illustration, 2) the tag part number at the bottom of the tag, and 3) the meaning of the tag.

**Display or Action**

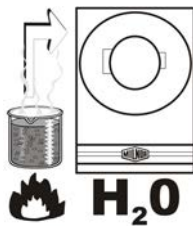
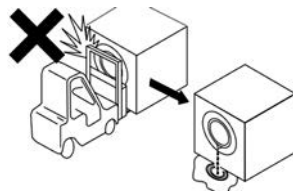

**Explanation**

Read the manuals before proceeding. This symbol appears on most tags. The machine ships with safety, operator, and routine maintenance guides for customer use. Milnor dealer manuals for installing, commissioning, and servicing the machine are also available from the Milnor Parts department.

B2TAG88005: This carefully built product was tested and inspected to meet Milnor performance and quality standards by (identification mark of tester).

B2TAG94078: Do not forklift here; do not jack here; do not step here—whichever applies.

B2TAG94081: Motor must rotate in this direction. On single motor washer-extractors and centrifugal extractors, the drive motor must turn in this direction during draining and extraction. This tag is usually wrapped around a motor housing. If the motor turns in the opposite direction when the machine is first tested, the electrical hookup is incorrect and must be reversed as explained in the schematic manual.

B2TAG94097: The cylinder must rotate **counterclockwise** during draining and extraction (spin) when viewed from here (rear of machine). Otherwise, reverse the electric power connections, as explained in the schematic manual.

B2TAG94099: Do not strike the shell door when fork-lifting. This can cause the door to leak.

B2T2001013: Hot water connection.



B2T2001014: Cold water connection.

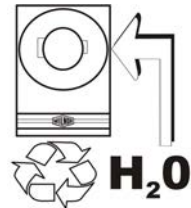

B2T2001015: Reuse (third) water connection.

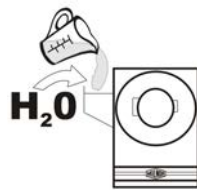

B2T2001016: Flushing water connection. This is the water that goes into the supply compartment or pumped chemical manifold to flush chemicals into the machine.

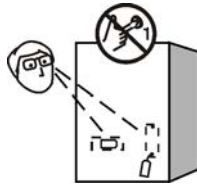

B2T2001028: Look for tags inside the machine. These tags may identify shipping restraints to be removed or components to be installed. Do not start the machine until these actions are completed.



B2T2002013: Do not start the machine until shipping restraints are removed. This tag will appear on the outside of the machine to alert you to the presence of internal shipping restraints. A tag will also appear on the restraint to help identify it. Most, but not all shipping restraints display the color red. Some shipping restraints are also safety stands. Do not discard these.

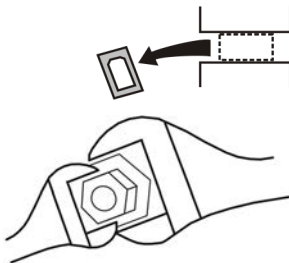

B2T2003001: Hold the side of the connection stationary with a wrench as you tighten the connection with another wrench. Otherwise, you may twist components, such as valves, damaging them.

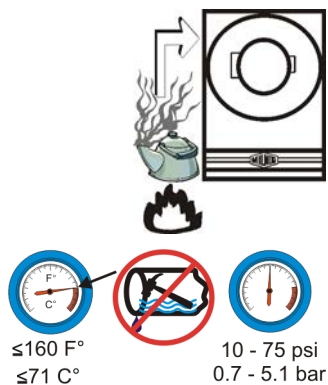

B2T2004027: Steam connection.

B2T2008007: Do not exceed 160° Fahrenheit (71° Celsius) water temperature. Excessive temperature can damage the water valves in this machine. Eliminate water hammer on the water lines to this machine. Water hammer can rupture the water inlet valves on this machine. Follow applicable codes when installing water hammer arresters. Maintain incoming water pressure between 10 and 75 psi (between 0.7 and 5.1 bar). Pressures outside this range can damage the water valves in this machine.

This page intentionally blank

## Safety Placards and Locations

2 Sheets

MWF100J7, MWF100Z7, MWF125J7, MWF125Z7



**NOTE:** Replace placard immediately, if removed or unreadable. Approximate locations of placards are shown. If aluminum placard, mounting holes are provided on machine. Use #8 self-tapping screws.

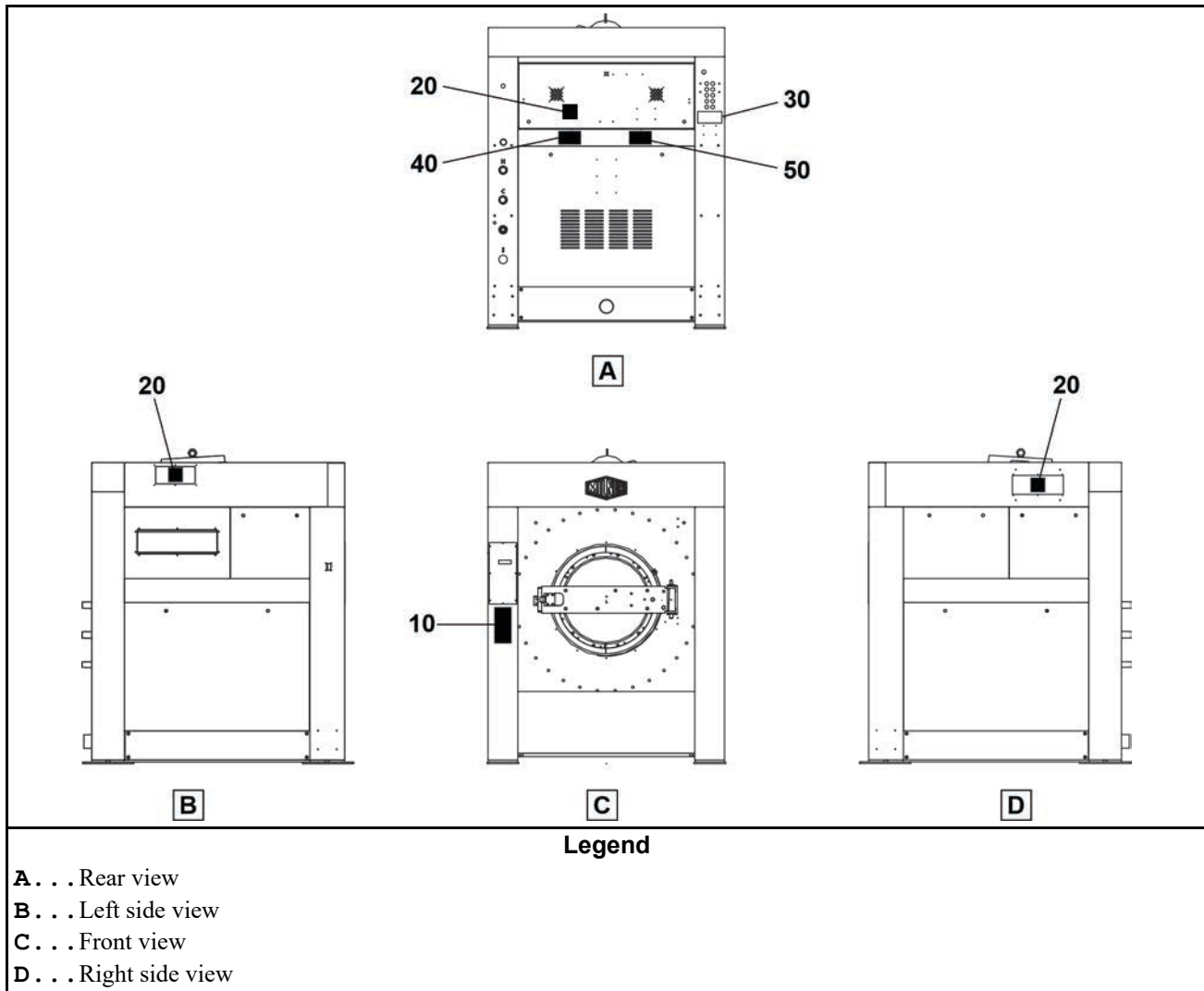



## Safety Placards and Locations

2 Sheets

MWF100J7, MWF100Z7, MWF125J7, MWF125Z7

**Table 2. Parts List—Safety Placards and Locations**

Find the assembly for your machine and the letter shown in the "Item" column. The components for your machine will show this letter or the word "all" in the "Used In" column. The numbers shown in the "Item" column are those shown in the illustrations.				
Used In	Item	Part Number	Description/Nomenclature	Comments
Components				
all	10	01 10631A	NPLT:SHELL FRT WARN NOTILT-TCA	
all	20	01 10377A	NPLT:ELEC HAZARD LG-TCATA	
all	30	01 10710A	NPLT:CAUTION CHEMICAL SYSTEM	
all	40	01 10699A	NPLT:SERV HZRD-PLYEST-TCATA	
all	50	01 10689A	NPLT:BELT HAZARD SM TCATA	

**Safety Placards and Locations—ISO**

MWF100J7, MWF100Z7, MWF125J7, MWF125Z7



**NOTE:** Replace placard immediately, if removed or unreadable. Approximate locations of placards are shown. If aluminum placard, mounting holes are provided on machine. Use #8 self-tapping screws.

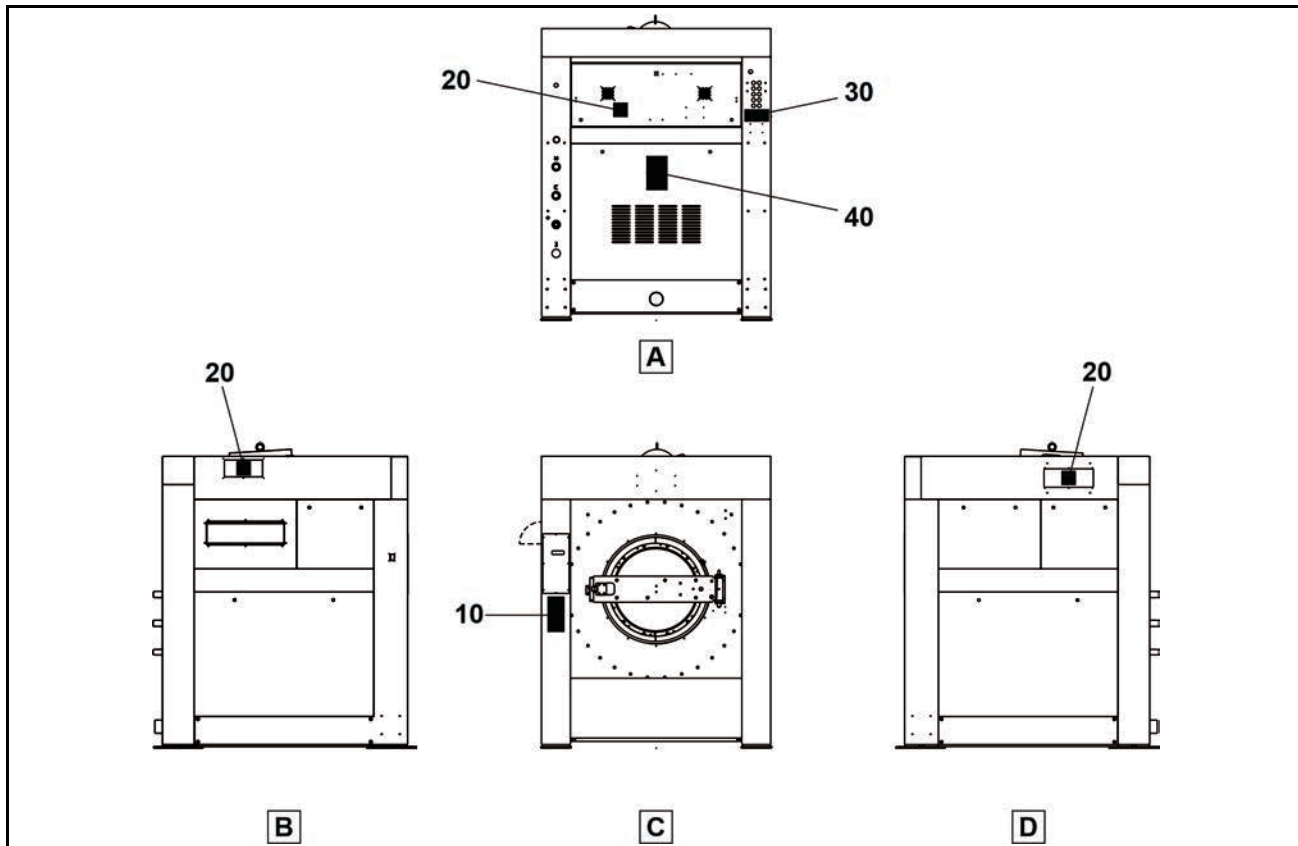

**Legend**

- A . . . Rear view
- B . . . Left side view
- C . . . Front view
- D . . . Right side view

**Table 3. Parts List—Safety Placards and Locations—ISO**

Find the assembly for your machine and the letter shown in the "Item" column. The components for your machine will show this letter or the word "all" in the "Used In" column. The numbers shown in the "Item" column are those shown in the illustrations.

Used In	Item	Part Number	Description/Nomenclature	Comments
Components				
all	10	01 10631Z	NPLT:SHELL MWF FRT WARN -ISO	
all	20	01 10377	NPLTE:"WARNING" 4X4	
all	30	01 10710A	NPLT:CAUTION CHEMICAL SYSTEM	
all	40	01 10628X	NPLT:NONTILT W/E WARNING SIDE	

This page intentionally blank

**Guards & Covers**

MWF100J7, MWF100Z7, MWF125J7, MWF125Z7

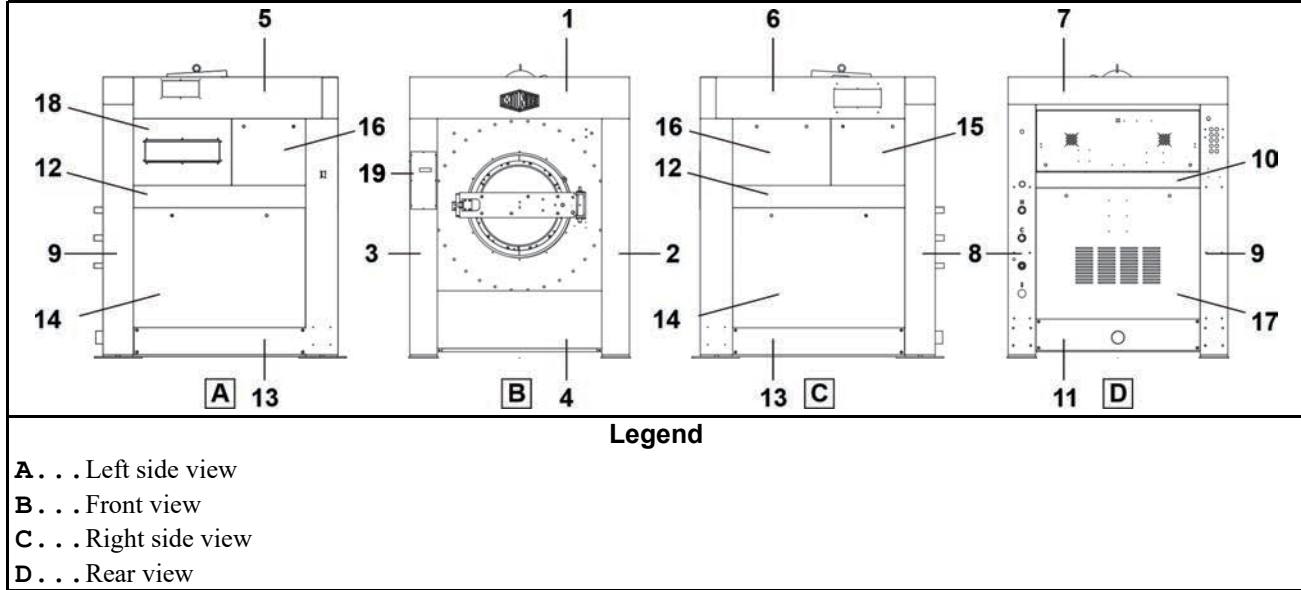

**Table 4. Parts List—Guards & Covers**

Find the assembly for your machine and the letter shown in the "Item" column. The components for your machine will show this letter or the word "all" in the "Used In" column. The numbers shown in the "Item" column are those shown in the illustrations.

Used In	Item	Part Number	Description/Nomenclature	Comments
Reference Assemblies				
A			REFERENCE	MWF100C7/Y7
B			REFERENCE	MWF125C7/Y7
Components				
all	1	98MW90801	FRONT UPPER PANEL, MWF100	
all	2	98MW90804A	FRONT RIGHT POST, MWF100	
all	3	98MW90804B	FRONT LEFT POST=EPPLUS, MWF100	
all	3	98MW90804C	FRONT LEFT POST=MILTOUCH, MWF100	
all	4	98MW90806	FRONT LOWER PANEL, MWF100	
all	5	98MW90802B	LEFT UPPER SUPPORT, MWF100	
all	5	98MW91802B	LEFT UPPER SUPPORT,MWF125	
all	6	98MW90802A	RIGHT UPPER SUPPORT, MWF100	
all	6	98MW91802A	RIGHT UPPER SUPPORT,MWF125	
all	7	98MW90808	REAR UPPER SUPPORT, MWF100	
all	8	98MW90805A	REAR RIGHT POST, MWF100	
all	9	98MW90805B	REAR LEFT POST, MWF100	
all	10	98MW90809	REAR MIDDLE SUPPORT, MWF100	
all	11	98MW90824	REAR LOWER SUPPORT, MWF100	
all	12	98MW90820B	SIDE MIDDLE SUPPORT, MWF100	

**Guards & Covers**

2 Sheets

MWF100J7, MWF100Z7, MWF125J7, MWF125Z7

**Table 4 Parts List—Guards & Covers (cont'd.)**

Find the assembly for your machine and the letter shown in the "Item" column. The components for your machine will show this letter or the word "all" in the "Used In" column. The numbers shown in the "Item" column are those shown in the illustrations.				
Used In	Item	Part Number	Description/Nomenclature	Comments
all	12	98MW91820	SIDE MIDDLE SUPPORT,MWF125	
all	13	98MW90807	SIDE LOWER SUPPORT, MWF100	
all	13	98MW91807	SIDE LOWER SUPPORT,MWF125	
all	14	98MW90810A	SIDE LOWER PANEL, MWF100	
all	15	98MW90821A	SIDE UPPER PANEL, MWF100	
all	16	98MW90823A	SIDE UPPER PANEL=REAR, MWF100	
all	16	98MW91823A	SIDE UPPER PANEL=REAR,MWF125	
all	17	98MW90825	REAR PANEL, MWF100	
all	18	98MW90821B	SIDE UPPER PANEL, 5-COMP. SUPPLY, MWF100	
all	18	98MW90821	SIDE UPPER PANEL, SOAP CHUTE, MWF100	
all	19	98MW2376B	LEFT PANEL=CONTROLLER MWF_Z	
all	19	98MW2376D	LEFT PANEL=CONTROLLER MWF_J	

BPWM3K01 / 2022052

BPWM3K01.1 0000406949 B.2 C.3 1/24/22, 12:42 PM Released

## Shipping Brackets

2 Sheets

MWF100J7, MWF100Z7, MWF100C7, MWF100Y7, MWF125J7, MWF125Z7, MWF125C7, MWF125Y7



**NOTE:** Before operating, remove the shipping brackets or bolts (painted red). The shipping brackets may be retained in the event the machine must be moved. See BNWUUI03.

Figure 1. Left Side View

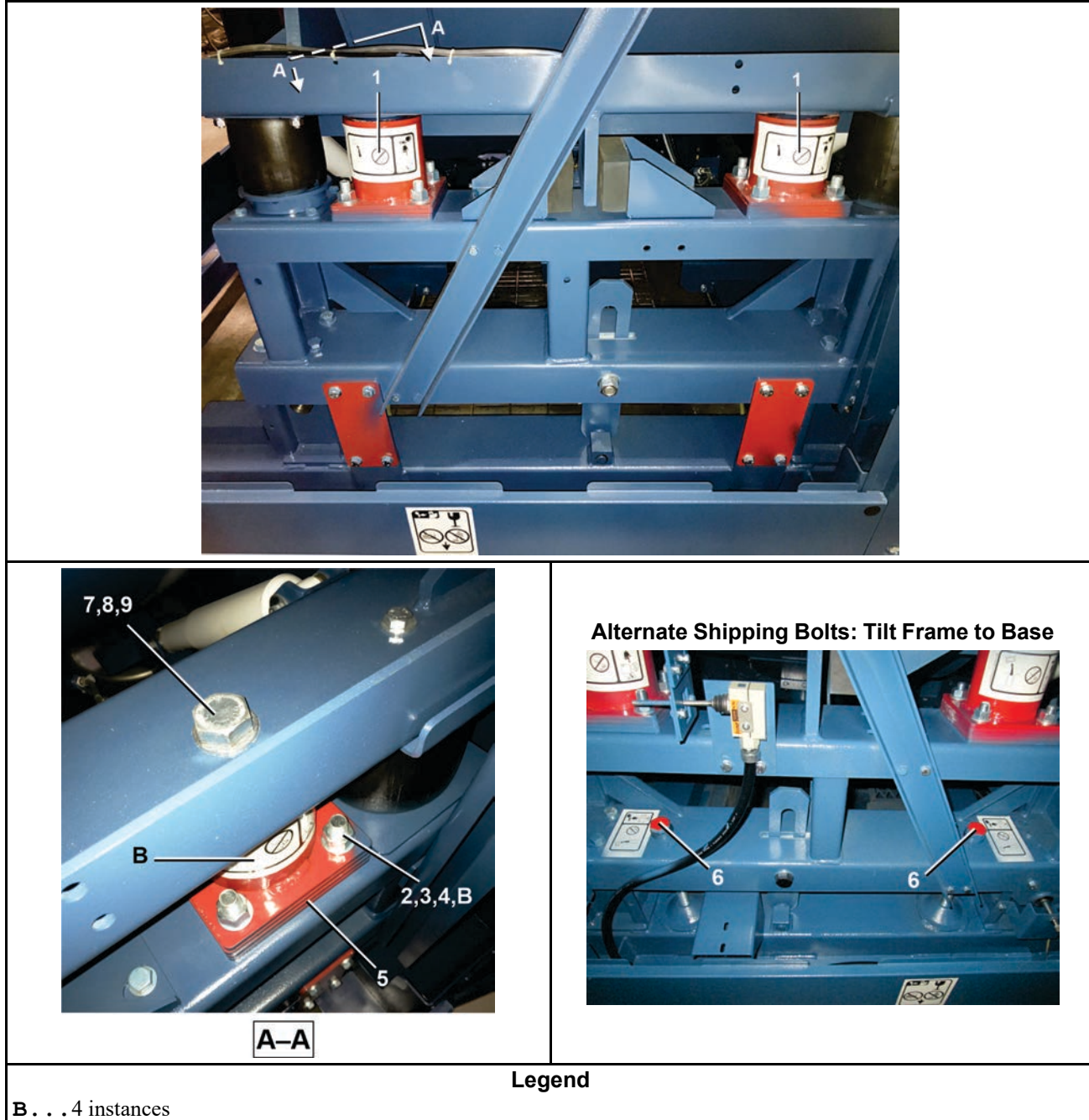

## Shipping Brackets

2 Sheets

MWF100J7, MWF100Z7, MWF100C7, MWF100Y7, MWF125J7, MWF125Z7, MWF125C7, MWF125Y7

**Table 5. Parts List—Shipping Brackets**

Find the assembly for your machine and the letter shown in the "Item" column. The components for your machine will show this letter or the word "all" in the "Used In" column. The numbers shown in the "Item" column are those shown in the illustrations.				
Used In	Item	Part Number	Description/Nomenclature	Comments
Components				
all	1	98MW25161A	HOLD DOWN WELDMENT, MWF77	
all	2	98CX770164	HEXCAPSCR M16X70, ZINC8.8	
all	3	98CX773515	FLATWASHER, D16 ZINC	
all	4	98CX773115	HEXNUT M16, ZINC	
all	5	98MW06406C	PLATE=SHIPPING BRACKST, MEF77	
all	6	15K253N	HEXCAPSCR M24-3.0X280 ZINC 8.8	
all	7	98CX770202	HEXCAPSCR M24X230, ZINC8.8	
all	8	15G250M	HEX NUT M24-3 ZINC	
all	9	98CX7735175	FLATWASHER, D24 ZINC	

## 1.5 Torque Requirements for Fasteners

BNUUUN02.C01 0000222451 A.3 B.3 C.3 1/2/20, 2:14 PM Released

The document about the assembly gives the torque requirements for other fasteners. **If fastener torque specifications or threadlocker requirements in an assembly document are different from this document, use the assembly document.**

**Figure 2. The Bolts in Milnor® Equipment**

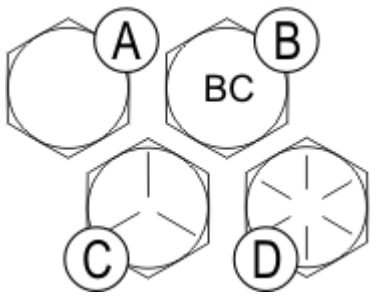
The Marks on Bolt Heads	Legend
	<p><b>A</b> . . . SAE Grades 1 and 2, ASTM A307, and stainless steel</p> <p><b>B</b> . . . Grade BC, ASTM A354</p> <p><b>C</b> . . . SAE Grade 5, ASTM A449</p> <p><b>D</b> . . . SAE Grade 8 and ASTM A354 BD</p>

### 1.5.1 Torque Values

BNUUUN02.C02 0000222449 A.3 B.3 C.3 1/2/20, 2:14 PM Released

These tables give the standard dimension, grade, threadlocker, and torque requirements for fasteners frequently used on Milnor® equipment.



**NOTE:** Data from the Pellerin Milnor® Corporation “Bolt Torque Specification” (bolt\_torque\_milnor.xls/2002096).

#### 1.5.1.1 Fasteners Made of Carbon Steel

BNUUUN02.C03 0000222448 A.3 B.3 C.3 1/2/20, 2:14 PM Released

##### 1.5.1.1.1 Without a Threadlocker

BNUUUN02.C04 0000222447 A.3 B.3 C.3 1/2/20, 2:14 PM Released

**Table 6. Torque Values for Standard Fasteners with Maximum 5/16-inch Diameters and No Lubricant**

Dimension	The Grade of the Bolt							
	Grade 2		Grade 5		Grade 8		Grade BC	
	Pound-Inches	N-m	Pound-Inches	N-m	Pound-Inches	N-m	Pound-Inches	N-m
1/4 x 20	66	7	101	11	143	16	126	14
1/4 x 28	76	9	116	13	163	18	–	–
5/16 x 18	136	15	209	24	295	33	258	29
5/16 x 24	150	17	232	26	325	37	–	–



**Table 7. Torque Values for Standard Fasteners Larger Than 5/16-inch Diameters and No Lubricant**

Dimension	The Grade of the Bolt							
	Grade 2		Grade 5		Grade 8		Grade BC	
	Pound-Feet	N-m	Pound-Feet	N-m	Pound-Feet	N-m	Pound-Feet	N-m
3/8 x 16	20	27	31	42	44	59	38	52
3/8 x 24	23	31	35	47	50	68	–	–
7/16 x 14	32	43	49	66	70	95	61	83
7/16 x 20	36	49	55	75	78	105	–	–
1/2 x 13	49	66	75	102	107	145	93	126
1/2 x 20	55	75	85	115	120	163	–	–
9/16 x 12	70	95	109	148	154	209	134	182
9/16 x 18	78	106	121	164	171	232	–	–
5/8 x 11	97	131	150	203	212	287	186	252
5/8 x 18	110	149	170	231	240	325	–	–
3/4 x 10	172	233	266	361	376	510	329	446
3/4 x 16	192	261	297	403	420	569	–	–
7/8 x 9	167	226	429	582	606	821	531	719
7/8 x 14	184	249	473	641	668	906	–	–
1 x 8	250	339	644	873	909	1232	796	1079
1 x 12	274	371	704	954	994	1348	–	–
1 x 14	281	381	723	980	1020	1383	–	–
1 1/8 x 7	354	480	794	1077	1287	1745	1126	1527
1 1/8 x 12	397	538	891	1208	1444	1958	–	–
1 1/4 x 7	500	678	1120	1519	1817	2464	1590	2155
1 1/4 x 12	553	750	1241	1682	2012	2728	–	–
1 3/8 x 6	655	888	1469	1992	2382	3230	2085	2827
1 3/8 x 12	746	1011	1672	2267	2712	3677	–	–
1 1/2 x 6	869	1178	1949	2642	3161	4286	2767	3751
1 1/2 x 12	979	1327	2194	2974	3557	4822	–	–

**Table 8. Torque Values for Plated Fasteners with Maximum 5/16-inch Diameters and No Lubricant**

Dimension	The Grade of the Bolt							
	Grade 2		Grade 5		Grade 8		Grade BC	
	Pound-Inches	N-m	Pound-Inches	N-m	Pound-Inches	N-m	Pound-Inches	N-m
1/4 x 20	49	6	76	9	107	12	95	11
1/4 x 28	56	6	88	10	122	14	–	–
5/16 x 18	102	12	156	18	222	25	193	22
5/16 x 24	113	13	174	20	245	28	–	–

**Table 9. Torque Values for Plated Fasteners Larger Than 5/16-inch Diameters and No Lubricant**

Dimension	The Grade of the Bolt							
	Grade 2		Grade 5		Grade 8		Grade BC	
	Pound-Feet	N-m	Pound-Feet	N-m	Pound-Feet	N-m	Pound-Feet	N-m
3/8 x 16	15	20	23	31	33	44	29	38
3/8 x 24	17	23	26	35	37	49	–	–
7/16 x 14	24	32	37	50	52	71	46	61
7/16 x 20	27	36	41	55	58	78	–	–
1/2 x 13	37	49	56	76	80	106	70	93
1/2 x 20	41	55	64	85	90	120	–	–
9/16 x 12	53	70	81	110	115	153	101	134
9/16 x 18	59	79	91	122	128	174	–	–
5/8 x 11	73	97	113	150	159	212	139	186
5/8 x 18	83	110	127	172	180	240	–	–
3/4 x 10	129	173	200	266	282	376	246	329
3/4 x 16	144	192	223	297	315	420	–	–
7/8 x 9	125	166	322	430	455	606	398	531
7/8 x 14	138	184	355	474	501	668	–	–
1 x 8	188	250	483	644	682	909	597	796
1 x 12	205	274	528	716	746	995	–	–
1 x 14	210	280	542	735	765	1037	–	–
1 1/8 x 7	266	354	595	807	966	1288	845	1126
1 1/8 x 12	298	404	668	890	1083	1444	–	–
1 1/4 x 7	375	500	840	1120	1363	1817	1192	1590
1 1/4 x 12	415	553	930	1261	1509	2013	–	–
1 3/8 x 6	491	655	1102	1470	1787	2382	1564	2085
1 3/8 x 12	559	758	1254	1672	2034	2712	–	–
1 1/2 x 6	652	870	1462	1982	2371	3161	2075	2767
1 1/2 x 12	733	994	1645	2194	2668	3557	–	–

**1.5.1.1.2 With a Threadlocker**

BNUUUN02.C05 0000222446 A.3 B.3 C.3 1/2/20, 2:14 PM Released

**Table 10. Threadlocker by the Diameter of the Bolt (see below Note )**

LocTite Product	Dimension			
	1/4-inch	1/4- to 5/8-inch	5/8- to 7/8-inch	1-inch +
LocTite 222	OK			
LocTite 242			OK	
LocTite 262				OK
LocTite 272				High temperature
LocTite 277				OK



**NOTE:** The acceptable bolt size ranges for various LocTite® threadlocking products is the LocTite manufacturer’s **general** recommendation. Specific applications sometime require that a LocTite product is applied to a bolt size outside the ranges shown here. For example, Milnor® specifies LocTite 242 for use on certain 1" bolt applications and has confirmed this usage with the LocTite manufacturer. You may see variances such as this in the documentation for specific machine assemblies.

**Table 11. Torque Values if You Apply LocTite 222**

Dimension	The Grade of the Bolt							
	Grade 2		Grade 5		Grade 8		Grade BC	
	Pound-Inches	N-m	Pound-Inches	N-m	Pound-Inches	N-m	Pound-Inches	N-m
1/4 x 20	60	7	96	11	132	15	108	12
1/4 x 28	72	8	108	12	144	16	–	–

**Table 12. Torque Values if You Apply LocTite 242**

Dimension	The Grade of the Bolt							
	Grade 2		Grade 5		Grade 8		Grade BC	
	Pound-Feet	N-m	Pound-Feet	N-m	Pound-Feet	N-m	Pound-Feet	N-m
5/16 x 18	11	15	17	23	25	34	22	30
5/16 x 24	13	18	19	26	27	37	27	37
3/8 x 16	20	27	31	42	44	60	38	52
3/8 x 24	23	31	35	47	50	68	–	–
7/16 x 14	32	43	49	66	70	95	61	83
7/16 x 20	36	49	55	75	78	106	–	–
1/2 x 13	49	66	75	102	107	145	93	126
1/2 x 20	55	75	85	115	120	163	–	–
9/16 x 12	70	95	109	148	154	209	134	182
9/16 x 18	78	106	121	164	171	232	–	–
5/8 x 11	97	132	150	203	212	287	186	252
5/8 x 18	110	149	170	230	240	325	–	–

**Table 13. Torque Values if You Apply LocTite 262**

Dimension	The Grade of the Bolt							
	Grade 2		Grade 5		Grade 8		Grade BC	
	Pound-Feet	N-m	Pound-Feet	N-m	Pound-Feet	N-m	Pound-Feet	N-m
3/4 x 10	155	210	240	325	338	458	296	401
3/4 x 16	173	235	267	362	378	512	–	–
7/8 x 9	150	203	386	523	546	740	477	647
7/8 x 14	165	224	426	578	601	815	–	–

**Table 14. Torque Values if You Apply LocTite 272 (High-Temperature)**

Dimension	The Grade of the Bolt							
	Grade 2		Grade 5		Grade 8		Grade BC	
	Pound-Feet	N-m	Pound-Feet	N-m	Pound-Feet	N-m	Pound-Feet	N-m
1 x 8	350	475	901	1222	1272	1725	1114	1510
1 x 12	383	519	986	1337	1392	1887	–	–

**Table 14 Torque Values if You Apply LocTite 272 (High-Temperature) (cont'd.)**

Dimension	The Grade of the Bolt							
	Grade 2		Grade 5		Grade 8		Grade BC	
	Pound-Feet	N-m	Pound-Feet	N-m	Pound-Feet	N-m	Pound-Feet	N-m
1 x 14	393	533	1012	1372	1428	1936	–	–
1-1/8 x 7	496	672	1111	1506	1802	2443	1577	2138
1-1/8 x 12	556	754	1247	1691	2022	2741	–	–
1-1/4 x 7	700	949	1568	2126	2544	3449	2226	3018
1-1/4 x 12	774	1049	1737	2355	2816	3818	–	–
1-3/8 x 6	917	1243	2056	2788	3335	4522	2919	3958
1-3/8 x 12	1044	1415	2341	3174	3797	5148	–	–
1-1/2 x 6	1217	1650	2729	3700	4426	6001	3873	5251
1-1/2 x 12	1369	1856	3071	4164	4980	6752	–	–

**Table 15. Torque Values if You Apply LocTite 277**

Dimension	The Grade of the Bolt							
	Grade 2		Grade 5		Grade 8		Grade BC	
	Pound-Feet	N-m	Pound-Feet	N-m	Pound-Feet	N-m	Pound-Feet	N-m
1 x 8	325	441	837	1135	1181	1601	1034	1402
1 x 12	356	483	916	1242	1293	1753	–	–
1 x 14	365	495	939	1273	1326	1798	–	–
1-1/8 x 7	461	625	1032	1399	1674	2270	1464	1985
1-1/8 x 12	516	700	1158	1570	1877	2545	–	–
1-1/4 x 7	650	881	1456	1974	2362	3202	2067	2802
1-1/4 x 12	719	975	1613	2187	2615	3545	–	–
1-3/8 x 6	851	1154	1909	2588	3097	4199	2710	3674
1-3/8 x 12	970	1315	2174	2948	3526	4781	–	–
1-1/2 x 6	1130	1532	2534	3436	4110	5572	3597	4877
1-1/2 x 12	1271	1723	2852	3867	4624	6269	–	–

**1.5.1.2 Stainless Steel Fasteners**

BNUUUN02.C06 0000222445 A.3 B.3 C.3 1/2/20, 2:14 PM Released

**Table 16. Torque Values for Stainless Steel Fasteners 5/16-inch and Smaller**

Dimension	316 Stainless		18-8 Stainless		18-8 Stainless with Loctite 767	
	Pound-Inches	N-m	Pound-Inches	N-m	Pound-Inches	N-m
1/4 x 20	79	9	76	9	45	5
1/4 x 28	100	11	94	11	56	6
5/16 x 18	138	16	132	15	79	9
5/16 x 24	148	17	142	16	85	10

**Table 17. Torque Values for Stainless Steel Fasteners Larger Than 5/16-inch**

Dimension	316 Stainless		18-8 Stainless		18-8 Stainless with Loctite 767	
	Pound-Feet	N-m	Pound-Feet	N-m	Pound-Feet	N-m
3/8 x 16	21	28	20	27	12	16
3/8 x 24	23	31	22	29	13	18
7/16 x 14	33	44	31	42	19	25
7/16 x 20	35	47	33	45	20	27
1/2 x 13	45	61	43	58	26	35
1/2 x 20	47	64	45	61	27	37
9/16 x 12	59	81	57	77	34	46
9/16 x 18	66	89	63	85	38	51
5/8 x 11	97	131	93	125	56	75
5/8 x 18	108	150	104	141	62	84
3/4 x 10	132	179	128	173	77	104
3/4 x 16	130	176	124	168	75	101
7/8 x 9	203	275	194	263	116	158
7/8 x 14	202	273	193	262	116	157
1 x 8	300	406	287	389	172	233
1 x 14	271	367	259	351	156	211
1-1/8 x 7	432	586	413	560	248	336
1-1/8 x 12	408	553	390	529	234	317
1-1/4 x 7	546	740	523	709	314	425
1-1/4 x 12	504	683	480	651	288	390
1-1/2 x 6	930	1261	888	1204	533	722
1-1/2 x 12	732	992	703	953	422	572

## 1.5.2 Preparation

BNUUUN02.T01 0000222511 B.2 B.3 C.3 4/20/23, 9:05 AM Released



**WARNING: Fire Hazard** — Some solvents and primers are flammable.

- ▶ Use threadlocker and primers with sufficient airflow.
- ▶ Do not use flammable material near ignition sources.

1. Clean all threads with a wire brush or a different tool.
2. Remove the grease from the fasteners and the mating threads with solvent. Make the parts dry.



**NOTE:** LocTite 7649 Primer™ or standard solvents will remove grease from parts.

3. Apply a spray of LocTite 7649 Primer™ or equal on the fasteners and the mating threads. Let the primer dry for one minute minimum.

### 1.5.3 How to Apply a Threadlocker

BNUUUN02.T02 0000222508 B.2 B.3 C.3 4/20/23, 9:09 AM Released

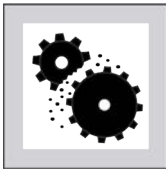

**CAUTION: Malfunction Hazard** — Heat, vibration, or mechanical shocks can let the fasteners loosen if you do not apply the threadlocker correctly. Loose fasteners can cause malfunctions of the equipment.

- ▶ Read the threadlocker manufacturer's instructions and warnings. Obey these instructions.

Apply the threadlocker only to the areas where the fastener threads and the mating threads engage.

**Figure 3. Apply Threadlocker in a Blind Hole**

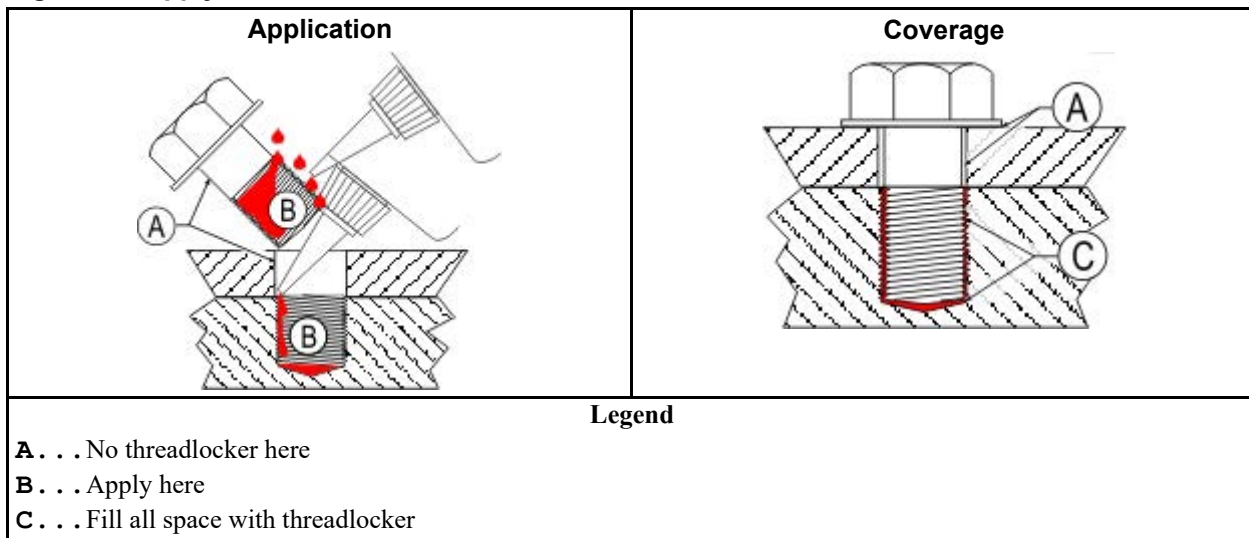

#### 1.5.3.1 Blind Holes

BNUUUN02.T03 0000222507 A.3 B.3 C.3 1/2/20, 2:14 PM Released

1. Apply the threadlocker down the threads to the bottom of the hole.
2. Apply the threadlocker to the bolt.
3. Tighten the bolt to the value shown in the correct table ([Table 10: Threadlocker by the Diameter of the Bolt \(see below Note \), page 28](#) to [Table 16: Torque Values for Stainless Steel Fasteners 5/16-inch and Smaller, page 30](#) ).

#### 1.5.3.2 Through Holes

BNUUUN02.T04 0000222506 A.3 B.3 C.3 11/26/19, 2:51 PM Released

1. Put the bolt through the assembly.
2. Apply the threadlocker only to the bolt thread area that will engage the nut.
3. Tighten the bolt to the value shown in the correct table ([Table 10: Threadlocker by the Diameter of the Bolt \(see below Note \), page 28](#) to [Table 16: Torque Values for Stainless Steel Fasteners 5/16-inch and Smaller, page 30](#) ).

**Figure 4. Apply Threadlocker in a Through Hole**

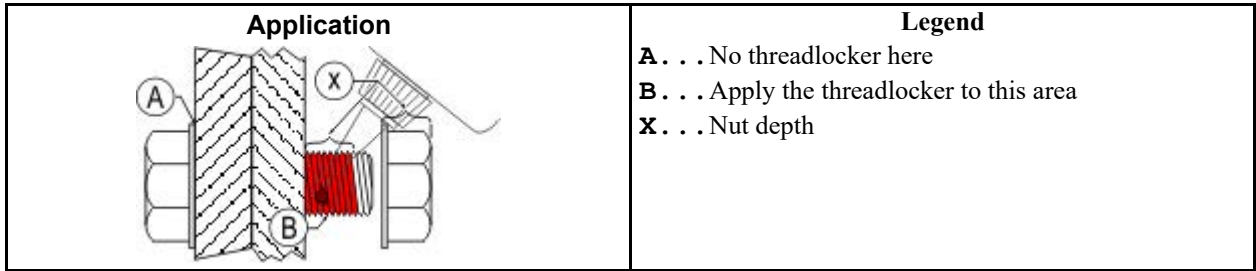

### 1.5.3.3 Disassembly

BNUUUN02.C07 0000222444 A.3 B.3 C.3 11/26/19, 2:59 PM Released

For high-strength threadlocker, apply heat for five minutes. Disassemble with hand tools while the parts are hot.

For low-strength and moderate-strength threadlocker, disassemble with hand tools.

**Figure 5. Use heat for disassembly of fasteners with threadlocker.**

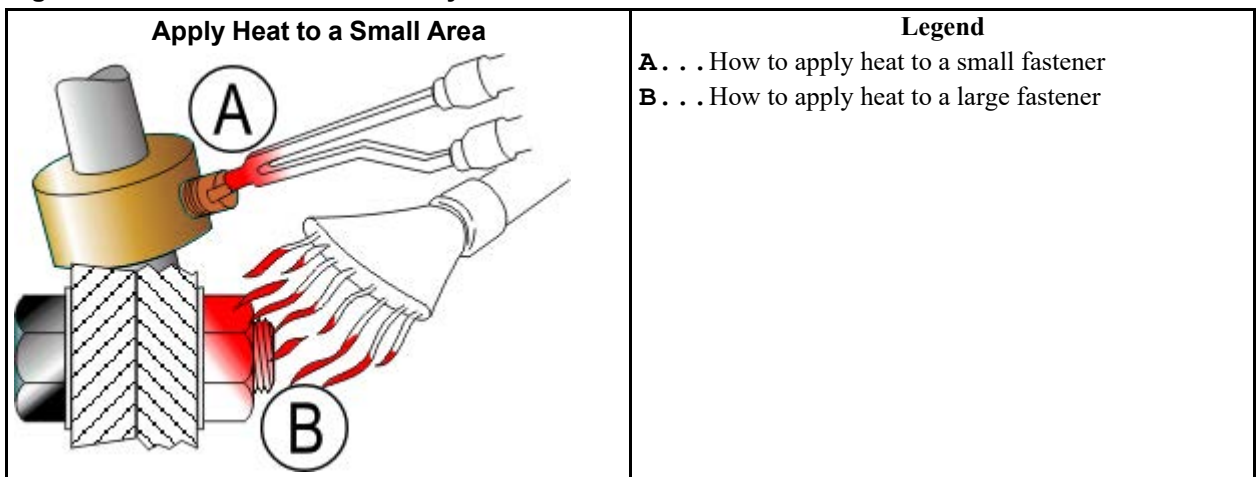

# 2 Important Installation Precautions

BFUUUF01 / 2023174

BNUUUF01 0000109243 C.3 4/26/23, 10:44 AM Released

## 2.1 External Fuse/Breaker, Wiring, and Disconnect Requirements

BNUUUF01.C01 0000109242 A.4 D.2 C.3 1/2/20, 2:14 PM Released

An external fuse **or** circuit breaker and a disconnect switch must be provided in the facility for (and dedicated to) the machine. These may be in the same or separate, **permanently mounted** electric boxes. Electric power and ground connections will be made between the incoming power junction box on the machine and this external box (or one of the boxes).

### 2.1.1 Fuse or Circuit Breaker Size

BNUUUF01.R01 0000109241 A.4 D.2 C.3 1/2/20, 2:14 PM Released

Refer to the “External Fuse and Wire Sizes...” document for your machine model. This document will be found in the machine's installation manual, available from the parts department. Choose the fuse or circuit breaker from the appropriate column of the table provided, as follows:

**If a fuse is used** — Match the fuse listed in the “Fuse” column for your machine's voltage. The specified fuse sizes are consistent with the USA National Electric Code (NEC), section 430-52, exception No. 2, Part B, which states: “The rating of a time-delay (dual-element) fuse shall be permitted to be increased, but shall in no case exceed 225 percent of the full-load current.”

**If a standard circuit breaker is used** — Match the amperage rating listed in the “Breaker” column for your machine's voltage.

**If an inverse time circuit breaker is used** — Match the characteristics (amperage rating) of the fuse listed in the “Fuse” column for your machine's voltage. When applied to an inverse time circuit breaker, the specified fuse sizes are consistent with the USA National Electric Code (NEC), section 430-52, exception No. 2, Part C, which states: “The rating of an inverse time circuit breaker shall be permitted to be increased, but shall in no case exceed 400 percent for full-load currents of 100 amperes or less.”

### 2.1.2 Wire Size

BNUUUF01.R02 0000109240 A.4 D.2 C.3 1/2/20, 2:14 PM Released

Use wiring no smaller than that listed for your machine's voltage in the “Wire size...” column in the “External Fuse and Wire Sizes...” document. The table value applies to runs up to 50 feet (15 meters). Use the next larger size for runs 50 to 100 feet (15 to 30 meters). Use wire two sizes larger for runs greater than 100 feet (30 meters). If an inverse time circuit breaker is used and local codes require a larger wire size than that specified by Milnor, abide by the local code.





**NOTICE:** The specified wire size may appear too small for the fuse or circuit breaker shown. However, it is consistent with both the load imposed and with the USA National Electric Code.

### 2.1.3 Ground

BNUUUF01.R03 0000109239 A.4 D.2 C.3 1/2/20, 2:14 PM Released

The ground wire and connections must ensure a reliable earth ground (zero potential). Use wiring of at least as large a gauge as that required for incoming power. Do not rely on conduit, machine anchorage, etc. Use the ground lug provided in the incoming power junction box on the machine.

### 2.1.4 Disconnect Switch for Lockout/Tagout

BNUUUF01.R04 0000109238 A.5 D.2 C.3 1/2/20, 2:14 PM Released

The disconnect switch must permit personnel to disconnect and lockout/tagout electric power from the machine. In the USA, refer to OSHA standard 1910.147 “The control of hazardous energy (lockout/tagout)”. Refer to the USA National Electric Code for requirements on locating the switch. In other locales, abide by these standards if no other local codes apply.

### 2.1.5 Using GFCI (Ground Fault Circuit Interrupter) Device

BNUUUF01.R05 0000571262 A.2 D.2 C.3 4/26/23, 10:44 AM Released

The AC Drive will most likely cause the GFCI protection device to trip. The reason the AC Drive will cause this tripping of the GFCI is the Common Mode Current or Common Mode Noise (CM Noise) that the VFD is producing.

Use a GFCI with a higher trip level.



**NOTE:** Choose a GFCI designed specifically for an AC drive. The operation time should be at least 0.1 s with sensitivity amperage of at least 200 mA per drive. The output waveform of the drive may cause an increase in leakage current. This may in turn cause the leakage breaker to malfunction. Increase the sensitivity amperage or lower the carrier frequency to correct the problem.

Use a type B GFCI according to IEC/EN 60755.

BNUUUI01 / 2019392

BNUUUI01 0000189337

1/2/20, 2:14 PM Released

## 2.2 Vital Information About the Forces Imparted to Supporting Structures by Laundering Machines

BNUUUI01.C01 0000189336 A.5 C.3 1/2/20, 2:14 PM Released

This document replaces Milnor® document BIWUUI02.

All laundering machines impart static and dynamic forces to the supporting structures (foundation and soil, floor, and building). Static forces include the machine weight plus the weight of the goods and water. Dynamic forces are those imparted by various machine movements as explained in [Section 2.2.2 : Major Design Considerations, page 36](#). The dynamic forces imparted to supporting structures can cause vibration and noise outside of the laundry room if supporting structures are inadequate.

## 2.2.1 Disclaimer of Responsibility

BNUUUI01.C02 0000189359 B.3 C.3 1/2/20, 2:14 PM Released

Pellerin Milnor Corporation accepts no responsibility for damage or loss as a result of:

- inadequate supporting structures
- interference with the use of the facility caused by machine operation

The facility owner/operator is solely responsible to ensure that:

- supporting structures are strong enough, with a reasonable safety factor, to safely support the operating machine or group of machines
- supporting structures are rigid enough to isolate vibrations and noise to the laundry room

If the owner/operator does not possess the necessary expertise to ensure that the facility can safely and functionally accommodate the equipment, it will be necessary to consult the appropriate expert(s), such as a structural engineer, soils engineer, and/or architect.

## 2.2.2 Major Design Considerations

BNUUUI01.C03 0000189358 A.5 C.3 1/2/20, 2:14 PM Released

- Vibration and/or noise can be felt or heard outside of the laundry room as a result of the following, if supporting structures are not sufficiently rigid:
  - Extraction (the spinning cylinder) in washer-extractors and centrifugal extractors, imparts sinusoidal forces to supporting structures as shown in [Figure 6: How Rotating Forces Act On the Foundation, page 37](#) . In rigid washer-extractors, these forces are up to 30 times that of suspended washer-extractors of the same capacity.
  - Extraction forces can be magnified many times if the rotation frequency matches the resonant frequency of supporting structures. To avoid this, supporting structures must have a natural resonant frequency many times greater than any possible rotation speed of the machine or combination of rotation speeds of all machines.
  - Each time goods fall in the rotating cylinder of a washer, washer-extractor, centrifugal extractor, or dryer, this can impart a force to the supporting structures.
  - The intermittent start and stop actions of large components inside the machine, particularly in a tilting washer-extractor, press-extractor, or centrifugal extractor, can impart intermittent forces to the supporting structures.
- The possibility of adverse consequences is significantly greater for upper floor installations than for installations at grade. Always consult a structural engineer for such an installation.
- The possibility of adverse consequences is significantly greater for installations at grade if subsidence causes a void between the foundation and the soil or if the soil itself does not provide adequate strength and rigidity. Some possible remedies are the addition of pilings or a deeper foundation, installed as to be monolithic with the existing foundation.
- Machine forces can cause damage to the machine or the floor without the correct anchorage.
- Applicable building codes, even when met, do not guarantee sufficient structural support and isolation of machine forces to the laundry room.

**Figure 6. How Rotating Forces Act On the Foundation**

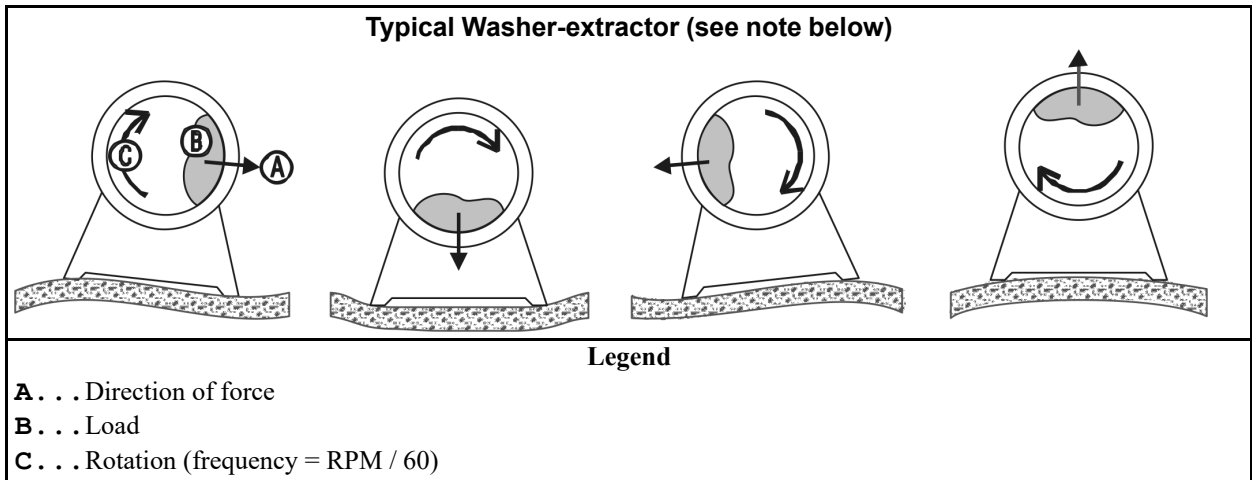

**NOTE:** This figure applies to both rigid and suspended washer-extractors and to both at-grade and upper floor installations.

### 2.2.3 Primary Information Sources

BNUUUI01.C04 0000189357 A.5 C.3 1/2/20, 2:14 PM Released

Milnor® provides, or can provide the following information of use to engineers and architects, for the given machine model:

- The machine dimensional drawing, found in the installation manual, specifies the machine’s required anchorage.
- The Milnor® Service Department can provide static and dynamic load values and frequency (extract speed) values on request.



**NOTICE:** All data is subject to change without notice and may have changed since last printed. It is the responsibility of the potential owner/operator to obtain written confirmation that any data furnished by Milnor® applies for the model number(s) and serial number(s) of the purchased machine(s).

BIWUUI03 / 2019296

BNUUUR02 0000160550 E.3 1/2/20, 2:14 PM Released

## 2.3 Prevent Damage from Chemical Supplies and Chemical Systems

BNUUUR02.C01 0000160549 B.3 C.3 E.3 1/2/20, 2:14 PM Released

All Milnor® washer-extractors and CBW® tunnel washers use stainless steel with the ANSI 304 specification. This material gives good performance when chemical supplies are correctly applied. If chemical supplies are incorrectly applied, this material can be damaged. The damage can be very bad and it can occur quickly.

Chemical supply companies usually:

- supply chemical pump systems that put the supplies in the machine,

- connect the chemical pump system to the machine,
- write wash formulas that control the chemical concentrations.

The company that does these procedures must make sure that these procedures do not cause damage. **Pellerin Milnor Corporation accepts no responsibility for chemical damage to the machines it makes or to the goods in a machine.**

### 2.3.1 How Chemical Supplies Can Cause Damage

BNUUUR02.R01 0000160548 B.5 C.3 E.3 10/1/21, 11:24 AM Released

**Dangerous Chemical Supplies and Wash Formulas** — Some examples that can cause damage are:

- a very high concentration of chlorine bleach,
- a mixture of acid sour and hypo chlorite,
- chemical supplies (examples: chlorine bleach, hydrofluosilicic acid) that stay on the stainless steel because they are not quickly flushed with water.

The book “Textile Laundering Technology” by Charles L. Riggs gives data about correct chemical supplies and formulas.

**Incorrect Configuration or Connection of Equipment** — Many chemical systems:

- do not prevent a vacuum in the chemical tube (for example, with a vacuum breaker) when the pump is off,
- do not prevent flow (for example, with a valve) where the chemical tube goes in the machine.

Damage will occur if a chemical supply can go in the machine when the chemical system is off. Some configurations of components can let the chemical supplies go in the machine by a siphon ([Figure 7, page 39](#)). Some can let chemical supplies go in the machine by gravity ([Figure 8, page 40](#)).

Figure 7. Incorrect Configurations That Let the Chemical Supply Go In the Machine by a Siphon

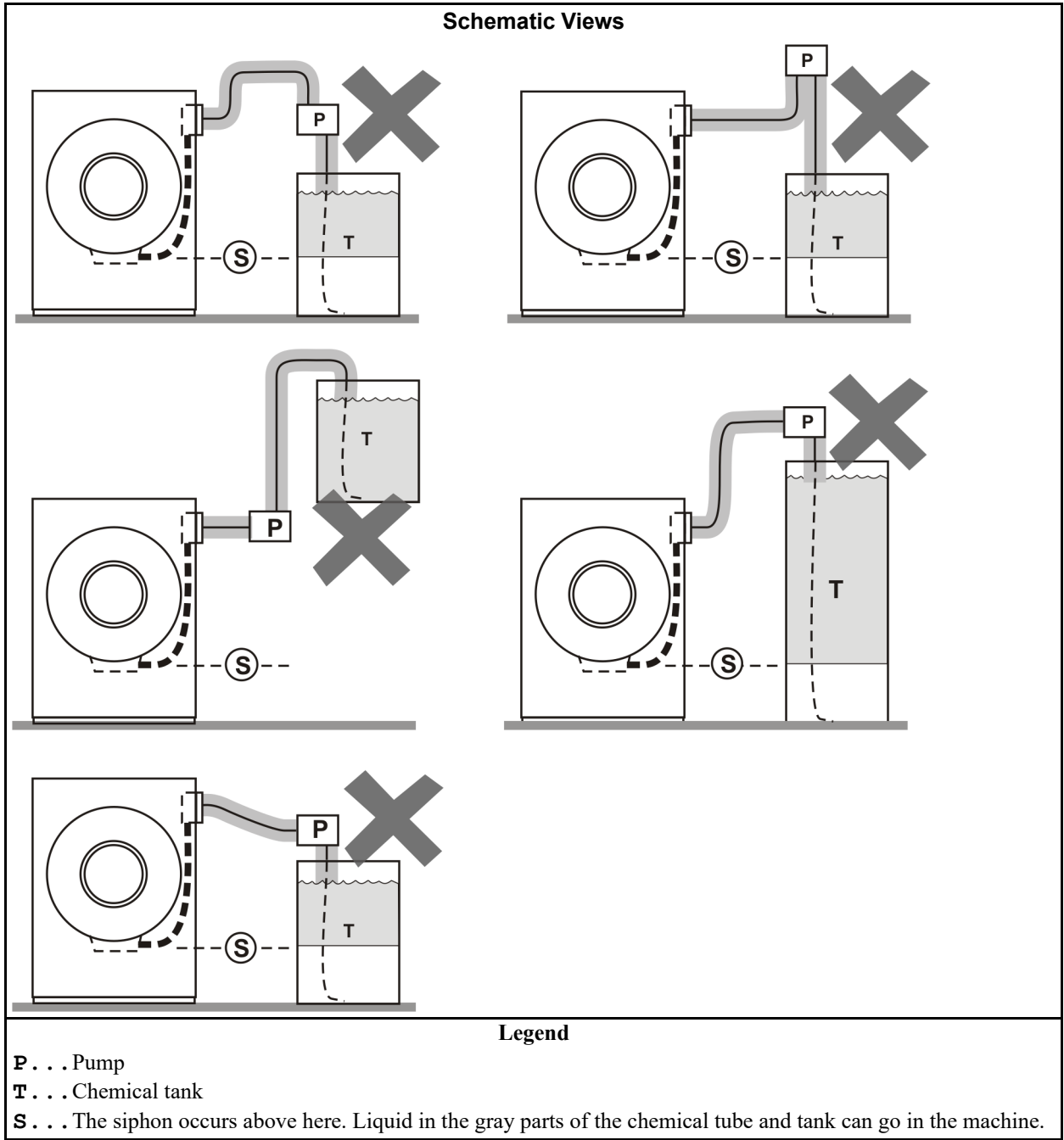

**Figure 8. Incorrect Configurations That Let the Chemical Supply Go In the Machine by Gravity**

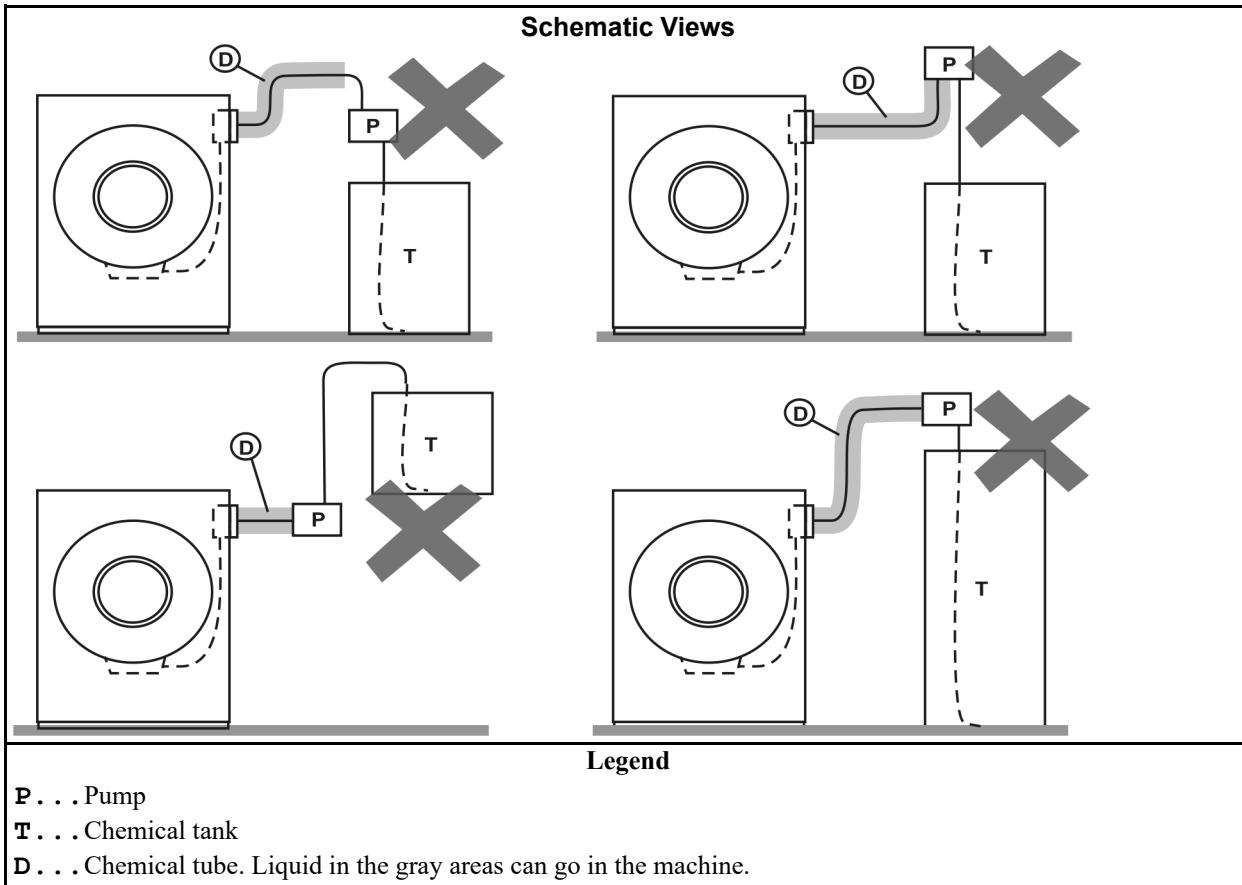

### 2.3.2 Equipment and Procedures That Can Prevent Damage

BNUUUR02.R02 0000160545 B.3 C.3 E.3 1/2/20, 2:14 PM Released

**Use the chemical manifold supplied.** — There is a manifold on the machine to attach chemical tubes from a chemical pump system. The manifold has a source of water to flush the chemical supplies with water.

**Figure 9. Examples of Manifolds for Chemical Tubes. Your equipment can look different.**

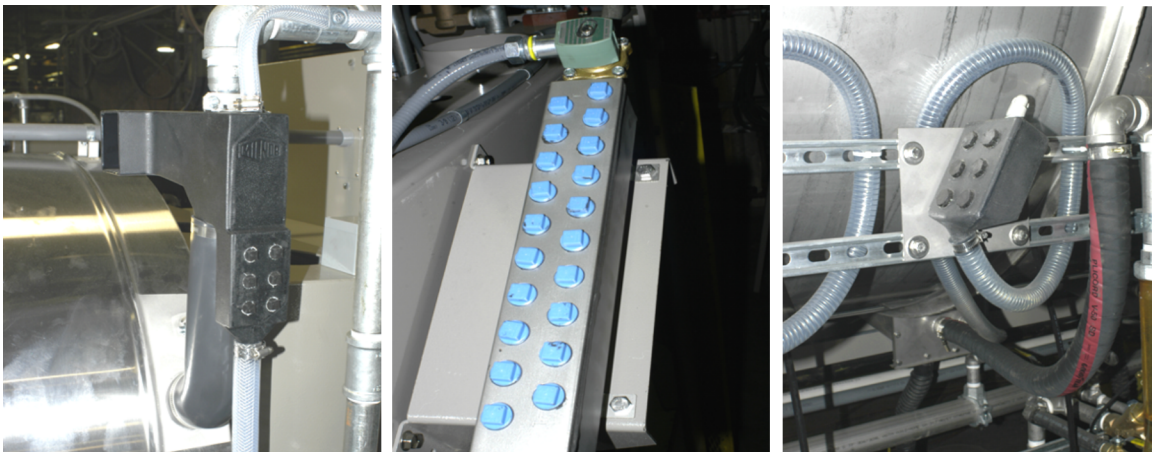

**Close the line.** — If the pump does not always close the line when it is off, use a shutoff valve to do this.

**Do not let a vacuum occur.** — Supply a vacuum breaker in the chemical line that is higher than the full level of the tank.

**Flush the chemical tube with water.** — If the liquid that stays in the tube between the pump and the machine can flow in the machine, flush the tube with water after the pump stops.

**Put the chemical tube fully below the inlet.** — It is also necessary that there is no pressure in the chemical tube or tank when the system is off.

**Figure 10. A Configuration that Prevents Flow in the Machine When the Pump is Off (if the chemical tube and tank have no pressure)**

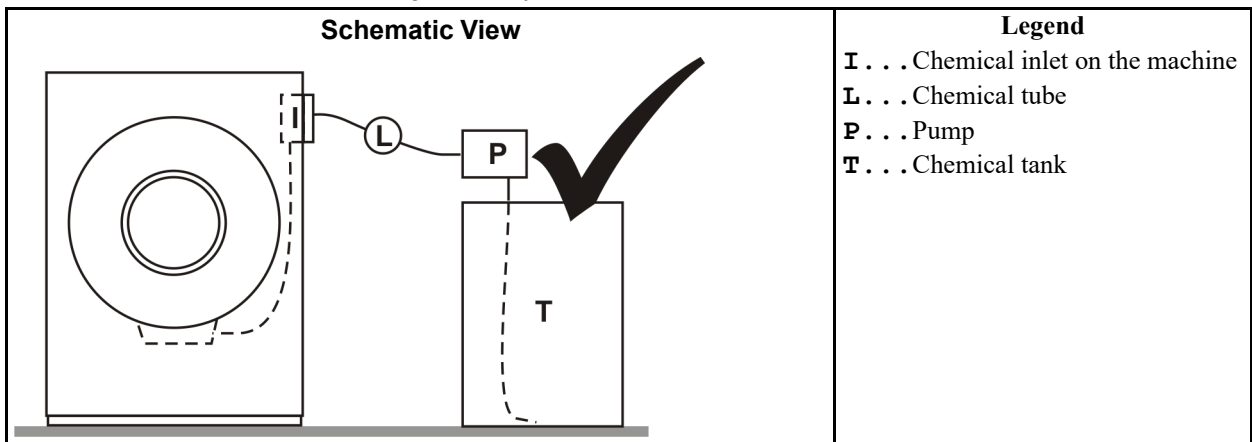

**Prevent leaks.** — When you do maintenance on the chemical pump system:

- Use the correct components.
- Make sure that all connections are the correct fit.
- Make sure that all connections are tight.

# 3 Installation Procedures

BNWUUI03 / 2019426

BNWUUI03 0000254788 B.7 1/2/20, 2:19 PM Released

## 3.1 Handling a Washer-extractor from Delivery to Final Location

BNWUUI03.C01 0000254787 C.3 C.5 B.7 1/2/20, 2:19 PM Released

This document supersedes documents BIIFLI01, BIRUUI01, MSIN0206AE, and MSIN0301AE as of October 1, 2019. It applies to all Milnor® washer-extractor models in production as of October 1, 2019.

**owner/management** the purchaser of the machine or their representative. Usually the consignee.

**transportation company** the person(s) or contractor(s) who transports the machine to the facility where it will be installed. The carrier.

**rigger** the person(s) or contractor(s) responsible to off-load the machine from the delivery vehicle, move it to its final location, and anchor it to the foundation. This can be the dealer but is often another company hired by the dealer.

**technician** a person trained in servicing Milnor® products and responsible to remove shipping restraints. This is usually a dealer employee.

### 3.1.1 Notices

BNWUUI03.R04 0000257899 A.4 C.3 B.7 1/2/20, 2:19 PM Released

**Qualified Personnel Only** — Do not attempt to move, anchor, or remove restraints from the machine unless you are a rigger or technician, as defined above.

**Disclaimer** — Pellerin Milnor Corporation is not responsible for damage to the machine after it leaves the factory. Pellerin Milnor Corporation strongly recommends that the consignee (usually the owner/management) carefully inspect the machine in its protective wrapping before off-loading and inspect the uncovered machine after off-loading. If damage occurred in transit, ensure that the transportation company acknowledges the damage in writing. Submit a damage claim as soon as possible.

**Other Tasks** — This document addresses common tasks that the rigger and technician will perform. Other tasks, not explained here, can be needed. Information about other tasks is usually provided by the dealer, the Milnor® Applications Engineering department, or the Milnor® Service department. Examples are:

- Placement of the machine on a platform, such as for laundry cart clearance or to accommodate unusual drain conditions.
- Partial disassembly and reassembly, possible on some models, for movement through small spaces.



### 3.1.2 Facility Prerequisites

BNWUUI03.R01 0000254786 B.4 C.3 B.7 1/2/20, 2:19 PM Released

Required Condition	Supporting Information
structural support	See document BNUUUI01 “Vital Information About the Forces Imparted to Supporting Structures by Laundering Machines” which can be found in the installation manual and also at <a href="https://milnor.sharefile.com/d-s8408ba617d244d98">https://milnor.sharefile.com/d-s8408ba617d244d98</a> .
protected storage	If the machine must be stored temporarily, it must be protected from dampness and excessive temperatures.
access to the final location	See the machine dimensional drawing, which can be found at the end of the installation manual, for overall dimensions. Partial disassembly is sometimes possible. Contact the Milnor® Service department.
clearances for machine movement and maintenance	See the dimensional drawing.
operational clearances	Adequate clearance around controls and for movement of laundry equipment such as carts. See the dimensional drawing.
available utilities	See the dimensional drawing and the external fuse and wire document.
available drain(s)	See the dimensional drawing. The drain valve(s) must have unrestricted access to a drain trough of sufficient capacity in the foundation.
laundry room ventilation	The machine will contribute heat and vapors to the laundry room, which must provide adequate ventilation.

### 3.1.3 Rigger Precautions

BNWUUI03.R02 0000254785 C.3 B.6 B.7 1/2/20, 2:19 PM Released



**CAUTION: Incorrect rigging** — can cause mishaps and costly machine damage.

- ▶ Know and accommodate the machine shipping weight.
- ▶ Use only lifting eyes for crane lifting.
- ▶ Use long cables or a spreader bar for crane lifting.
- ▶ Leave the machine skidded as long as possible.
- ▶ Protect fragile or sensitive machine components.
- ▶ Prepare the foundation and install anchor bolts correctly.
- ▶ Set the machine at the correct height and level.
- ▶ Apply machinery grout evenly so that support is distributed.
- ▶ Tighten anchors alternately so that the hold-down force is distributed.

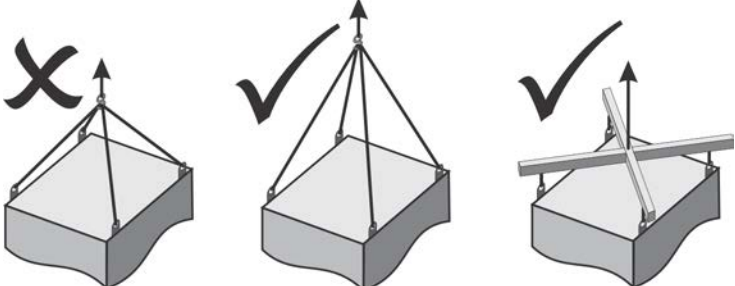
Precaution	Explanation
Know and accommodate the machine shipping weight.	Use lifting and moving equipment appropriate for the machine shipping weight, as shown on the Bill of Lading. To obtain the shipping weight in advance, contact the Milnor® Transportation department.
Use only lifting eyes for crane lifting.	Machines designed for crane lifting are provided with lifting eyes either on the structural frame or on the shell, hidden behind cosmetic panels.
Use long cables or a spreader bar for crane lifting.	
Leave the machine skidded as long as possible.	If the machine is skidded, leave the machine on the skids until the machine is as close as possible to its final location. Use care to avoid contact between the fork lift forks and fragile machine components on the un-skidded machine.
Protect fragile or sensitive machine components.	After the machine is uncovered, carefully find and read all tags on the outside of the machine. White and manila paper tags are installation precautions. See the Installation Tag Guidelines in the installation manual for additional information.
Prepare the foundation and install anchor bolts correctly.	Anchor bolt sizes and locations are shown on the dimensional drawing in the back of the installation manual. However, Milnor® recommends to use the actual machine as a template to accurately locate where the anchor bolts are to be installed in the foundation. See the anchor bolt detail on the dimensional drawing. It is not permissible to omit anchor bolts.

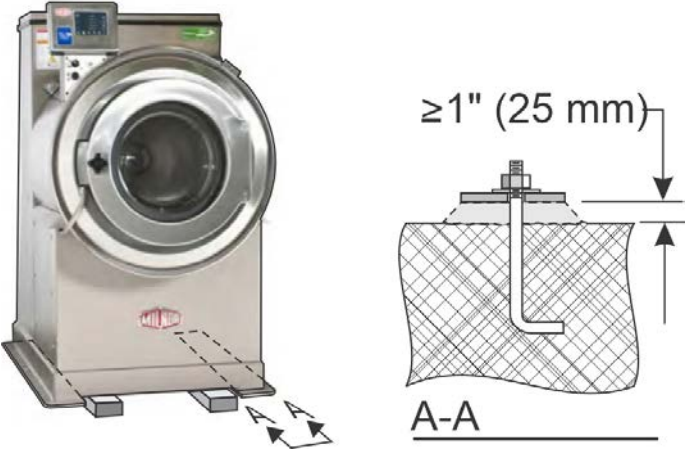
Precaution	Explanation
<p>Set the machine at the correct height and level.</p>	<p>Use blocking to get the machine base level and the base pads a minimum of 1" (25 mm) above the floor. Example:</p> 
<p>Apply machinery grout evenly so that support is distributed.</p>	<p>Fill all voids between the foundation and each base pad with industrial strength, non-shrinking grout. Allow the grout to fully cure per the grout instructions.</p>
<p>Tighten anchors alternately so that the hold-down force is distributed.</p>	<p>Raise the machine slightly and remove the wood blocking. Install a flat washer and nut on each anchor bolt and tighten incrementally in an alternating pattern. After tightening, check each anchor at least twice.</p>

### 3.1.4 Technician Precautions

BNWUUI03.R03 0000257735 A.5 C.3 B.7 1/2/20, 2:19 PM Released



**CAUTION: Overlooked or mishandled shipping restraints** — can cause costly machine damage.

- ▶ Leave all internal shipping restraints in place until the machine is anchored.
- ▶ Check for and remove shipping tie wraps.
- ▶ Check for and remove suspension hold-down hardware, if applicable.
- ▶ Check for and remove red shipping brackets, if applicable.
- ▶ See the “Cylinder inspection” warning and inspect the cylinder for smoothness.

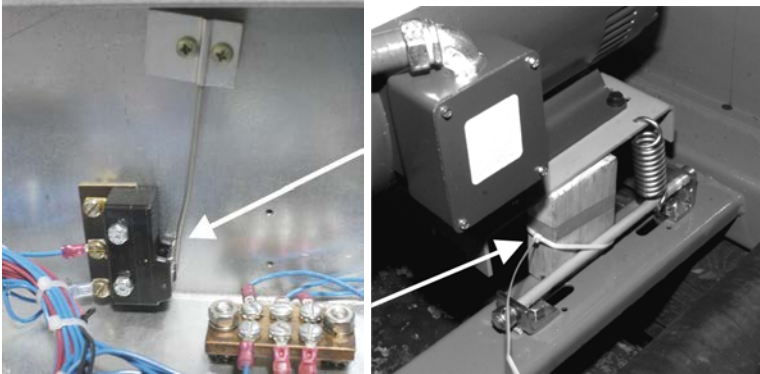
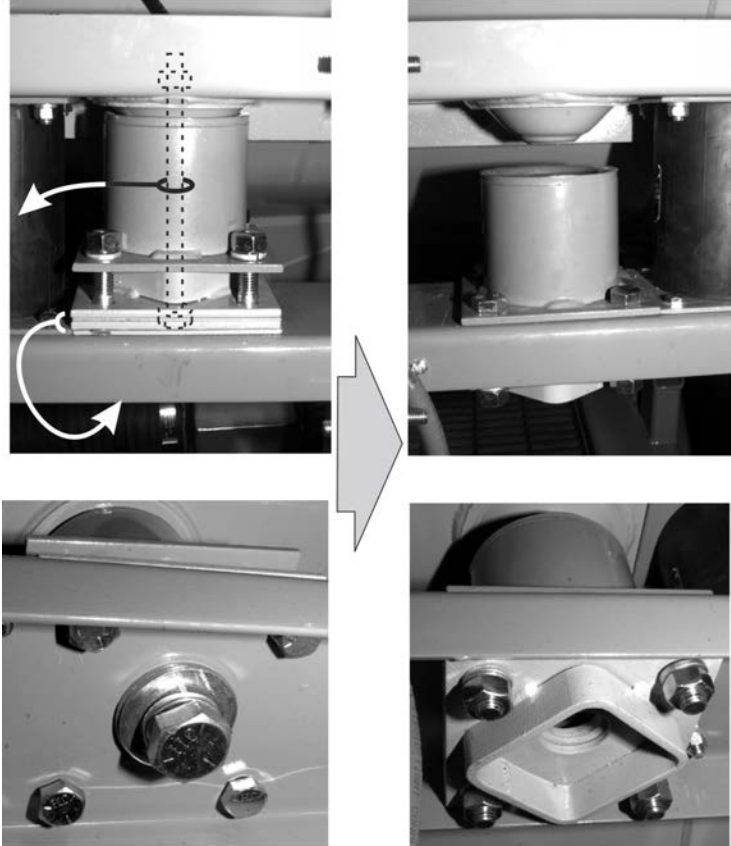
Precaution	Explanation
<p>Leave all internal shipping restraints in place until the machine is anchored.</p>	<p>The machine can have one or more internal shipping restraints to help protect components from damage until the machine is anchored. These are located inside the housing or inside electric cabinets.</p>
<p>Check for and remove shipping tie wraps.</p>	<p>Examples (varies with machine model):</p> 
<p>Check for and remove suspension hold-down hardware, if applicable.</p>	<p>See also the service manual. Example:</p> 
<p>Check for and remove red shipping brackets, if applicable.</p>	<p>Shipping brackets are painted red. See the shipping brackets parts document in the service manual.</p>



Precaution	Explanation
See the “Cylinder inspection” warning and inspect the cylinder for smoothness.	Inspect the cylinder and perforations for smoothness. <b>Pellerin Milnor Corporation cannot accept cylinder finish damage claims after the machine has been placed in service.</b> Machines are shipped with the shell door(s) closed. See the section below for information on how to open the shell door(s).



**WARNING: Cylinder inspection** — can trap you in the cylinder or seriously injure you.

- ▶ Never enter, or place body parts in the cylinder when power is supplied to the machine.
- ▶ If the machine is connected to power, lockout/tag-out power at the external disconnect switch.
- ▶ mechanically restrain the cylinder from turning.
- ▶ Have an assistant present in case of emergency.

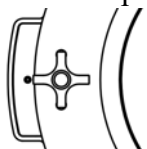
**Can the Door(s) Be Opened Before Utilities are Connected?** — The shell doors on all Milnor® washer-extractors in current production, except for the side-loading, barrier models, have one of two types of door latch: electric-operated or air operated.

Door Type	How To Open
Electric-operated: 	The machine leaves the factory with the door latched closed but not locked. Turn the door knob to open the door even when the machine does not have power. If the door will not open, the door lock mechanism moved to the locked position due to shaking in transit. In this event, wait until the machine is connected to electric power and use the controls to open the door.
Air-operated: 	The machine leaves the factory with the door(s) closed and locked (with the door plunger extended). It is possible to temporarily replace the air line that retracts the door plunger with a source of compressed air to open the door when no other utilities are connected. Otherwise, wait until utilities are connected to the machine and use the controls to open the door.

BNWUUI04 / 2021322

BNUUUF01 0000255072 C.3 8/2/21, 10:05 AM Released

### 3.2 Connection Precautions for Washer-extractors

BNWUUI04.C01 0000255071 B.2 C.2 C.3 8/2/21, 10:05 AM Released

This document supersedes documents BNWBUI01, BNWBUI02, BNWBUI03, BNWBUI04, BIRQVI01, BIMUUI02, and BIIFUI01. It applies to all Milnor® washer-extractor models in production as of October 1, 2019.

**plumber** the person(s) or contractor licensed or otherwise accepted by the local jurisdiction to perform the plumbing work described herein, and qualified to do so.

**electrician** the person(s) or contractor licensed or otherwise accepted by the local jurisdiction to perform the electrical work described herein, and qualified to do so.

**chemical supplier** the person(s) or contractor with detailed knowledge of 1) the machine controller configuration and operation, and 2) the pumped chemical delivery system, if such a system is to be used.

### 3.2.1 Notices

BNWUUI04.R03 0000255231 C.2 C.3 A.7 1/2/20, 2:19 PM Released

**Qualified Personnel Only** — Do not attempt to connect utilities to the machine unless you are a plumber, electrician, or chemical supplier, as defined above.

**Machine Must Be Anchored** — Utility connections are to be made only after the machine has been anchored. See BNWUUI03 “Handling a Washer-extractor from Delivery to Final Location.”

**Other Tasks** — This document and the documents it references address common tasks that the plumber, electrician, and chemical supplier will perform. Other tasks, not explained here, can be needed. Information about these tasks is usually provided by the dealer, the Milnor® Applications Engineering department, or the Milnor® Service department. An example is electrical interfacing with a remote Mildata® data collection system.

### 3.2.2 Utility Requirements and Related Information

BNWUUI04.R05 0000255583 A.12 C.2 C.3 1/2/20, 2:19 PM Released

Type of Information	Value or Where to Find
equipment list showing model and options purchased	For the dealer, see the order acknowledgement.
plumbing connection fitting types, sizes, and locations	See the standard and options dimensional drawings for your model located at the back of the installation manual.
water pressure range	10 – 75 psi (69 – 531 kPa) required
Cv value	See the specification sheet for your model available online at: <a href="https://www.milnor.com/specification-sheets/">https://www.milnor.com/specification-sheets/</a> . The Cv value assists the piping designer in determining flow rates and pressures.
steam pressure range	30 – 115 psi (207 – 793 kPa) required, if applicable
compressed air pressure range	85 – 110 psi (586 – 758 kPa) required, if applicable
specified voltage	See the machine nameplate or the order acknowledgement.

Type of Information	Value or Where to Find
available voltages for this model	See the specification sheet for your model available online at: <a href="https://www.milnor.com/specification-sheets/">https://www.milnor.com/specification-sheets/</a> .
multi-machine conditions that can interrupt utility service to a given machine	See dealer publication B22SL94011 “Sizing and Planning a Laundry” found online at: <a href="https://www.milnor.com/wp-content/uploads/2016/01/Sizing-and-Planning-a-Laundry_18323.pdf">https://www.milnor.com/wp-content/uploads/2016/01/Sizing-and-Planning-a-Laundry_18323.pdf</a>
approved plumbing materials	Plumbing materials must comply with applicable codes. The Milnor® factory makes no recommendations for inlet connection materials due to the many variables such as water conditions, materials cost and availability, and ongoing advances in materials technology. When drains must be piped, as apposed to a simple air drop to a sump, rubber hose and PVC are often used.

### 3.2.3 Plumber Precautions

BNWUUI04.R01 0000255070 C.2 C.3 A.9 1/2/20, 2:19 PM Released



**CAUTION: Machine damage and code violations** — can occur as a result of incorrect plumbing.

- ▶ Confirm the reliability of the piped utilities.
- ▶ Maintain connection point diameter.
- ▶ Flush fluid lines.
- ▶ Do not twist valve bodies.
- ▶ Never interchange water valve electrical connections.
- ▶ Install any vacuum breaker(s) provided or required.
- ▶ Install any water strainer(s) provided or required.
- ▶ Install a union and a shutoff valve at each hard piped connection.
- ▶ Connect a dry supply injector flush inlet to hot water and regulate it.

Precaution	Explanation
Confirm the reliability of the piped utilities.	Water and any other piped fluids (steam, compressed air) needed by the machine must be within the specified pressure range and not prone to frequent interruptions when the machine operates. See <a href="#">Section 3.2.2 : Utility Requirements and Related Information, page 48</a> .
Maintain connection point diameter.	The piping between the utility tap and the fitting on the machine must be as large or larger than the fitting. Drain piping or tubing, if any, must provide an unrestricted flow to the sump.
Flush fluid lines.	Foreign material such as debris in air lines, trapped air in water lines, and condensate in steam lines can damage machine components.
Do not twist valve bodies.	Hold a wrench on the valve side of a pipe connection to prevent the valve from twisting when you tighten the connection.



Precaution	Explanation
Never interchange water valve electrical connections.	On machines with air-operated water valves, it is permissible to exchange the pneumatic control lines, if the cold and hot connections were accidentally plumbed in reverse.
Install any vacuum breaker(s) provided or required.	If vacuum (siphon) breaker(s) are provided for fresh water connection (s), but not already installed, install them as shown on the options dimensional drawing. If vacuum breakers are required by code, but not provided, obtain and install the required hardware.
Install any water strainers provided or required.	If water strainer(s) are provided for fresh water connections, install them between the machine and incoming water. For machines with garden hose type water inlets, use 40-mesh strainers.
Install a union and a shutoff valve at each hard-piped connection.	Obtain and install the necessary hardware to permit hard-piped connections to be shut off and disconnected at the machine for maintenance. For the valve, use a ball valve, not, for example, a globe valve.
Connect a dry supply injector flush inlet to hot water and regulate it.	If the machine has a dry supply injector with an external flush water connection and hot water is available, provide hot water to this inlet. The machine will be supplied with a pressure regulator. Install this hardware at the flush water connection and confirm that the regulator is set to 28 psi (193 kPa). Steam in the hot water line will cause the supply injector to malfunction.

### 3.2.4 Electrician Precautions

BNWUUI04.R02 0000255232 C.2 C.3 A.7 1/2/20, 2:19 PM Released



**CAUTION: Machine damage, machine malfunctions, and code violations** — can occur as a result of incorrect electrical connections.

- ▶ Know the machine electrical specifications.
- ▶ Comply with the published external fuse and wire requirements.
- ▶ Confirm the reliability of the electric service.
- ▶ Confirm the machine is phased in correctly.
- ▶ Confirm the correct line voltage setting on a selectable 240/208 volt machine.
- ▶ Attach the stinger leg, if any, only to L3.



Precaution	Explanation
Know the machine electrical specifications.	Refer to the nameplate affixed to the machine.
Comply with the published external fuse and wire requirements.	These requirements are given in document BGUUUF01 “External Fuse/Breaker, Wiring, and Disconnect Requirements” and the external fuse and wire document for your machine. These documents are found at the back of the installation manual. BGUUUF01 is also available at: <a href="https://milnor.sharefile.com/d-s5e1bad2885a447e8">https://milnor.sharefile.com/d-s5e1bad2885a447e8</a>
Confirm the reliability of the electric service.	Voltage fluctuations of more than 10% above or below the specified voltage can damage electrical components, especially motors. The Milnor® factory strongly recommends that unreliable electric service is improved before the machine is put in use.
Confirm the machine is phased in correctly.	An installation tag on the machine shows the correct cylinder rotation at distribution (drain) or extract speed. If the cylinder turns in the wrong direction, reverse the wires connected to L1 and L2. Never move L3. Individual motors were phased in at the factory. Never reconnect individual motors or motor control devices.
Confirm the correct line voltage setting on a selectable 240/208 volt machine.	This precaution applies only if the nameplate voltage says 208/240V. It does not, for example, apply if the nameplate says 208V <b>or</b> 240V. The switch is near the incoming power transformer and must be in the position that matches the service voltage: 240 VAC or 208 VAC.
Attach the stinger leg, if any, only to terminal L3.	Never attach a stinger leg to terminal L1 or terminal L2.

### 3.2.5 Chemical Supplier Precautions

BNWUUI04.R04 0000255482 C.2 A.5 C.3 1/2/20, 2:19 PM Released

**Injury and severe machine damage** can occur as a result of incorrect chemical system installation.

- ▶ Understand and comply with the published connection precautions.
- ▶ Understand the machine controller.

Precaution	Explanation
Understand and comply with the published connection precautions.	The connection precautions are given in document BIWUUI03 “Prevent Damage from Chemical Supplies and Chemical Systems” in the installation manual. BIWUUI03 is also available at: <a href="https://milnor.sharefile.com/d-s79f12e8f11f42a9b">https://milnor.sharefile.com/d-s79f12e8f11f42a9b</a>
Understand the machine controller.	The machine controller is explained in detail in the reference manual for your machine, which is available from the Milnor® Parts department.

# 4 Drive Assemblies

BPWMEI01 / 2022055

BPWMEI01.1 0000406984 A.4 C.3 1/27/22, 3:10 PM Released

## Drive Components

1 Sheet

MWF100J7, MWF100C7, MWF100Y7



**NOTE:** See “How to Examine Belts and Pulleys” found in Supplement 1 of the Maintenance Guide.

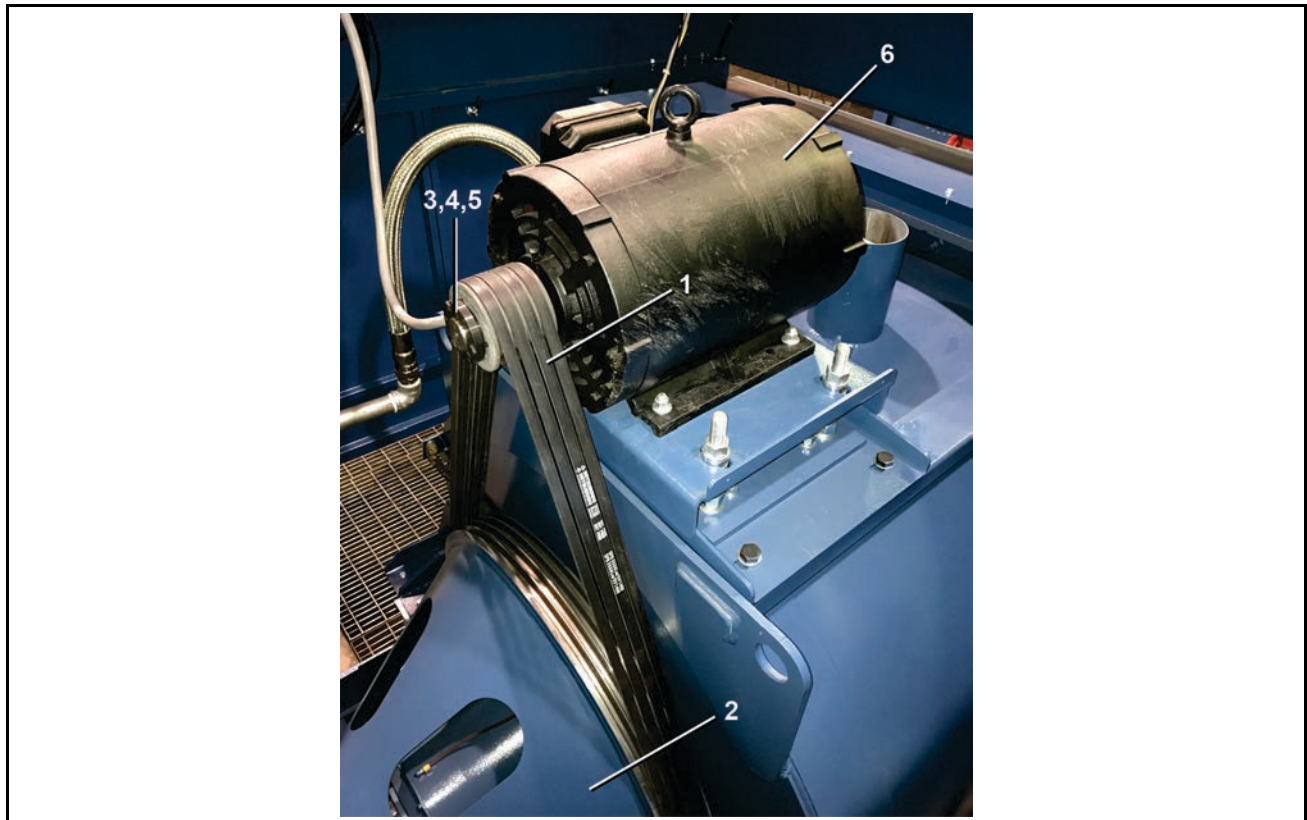
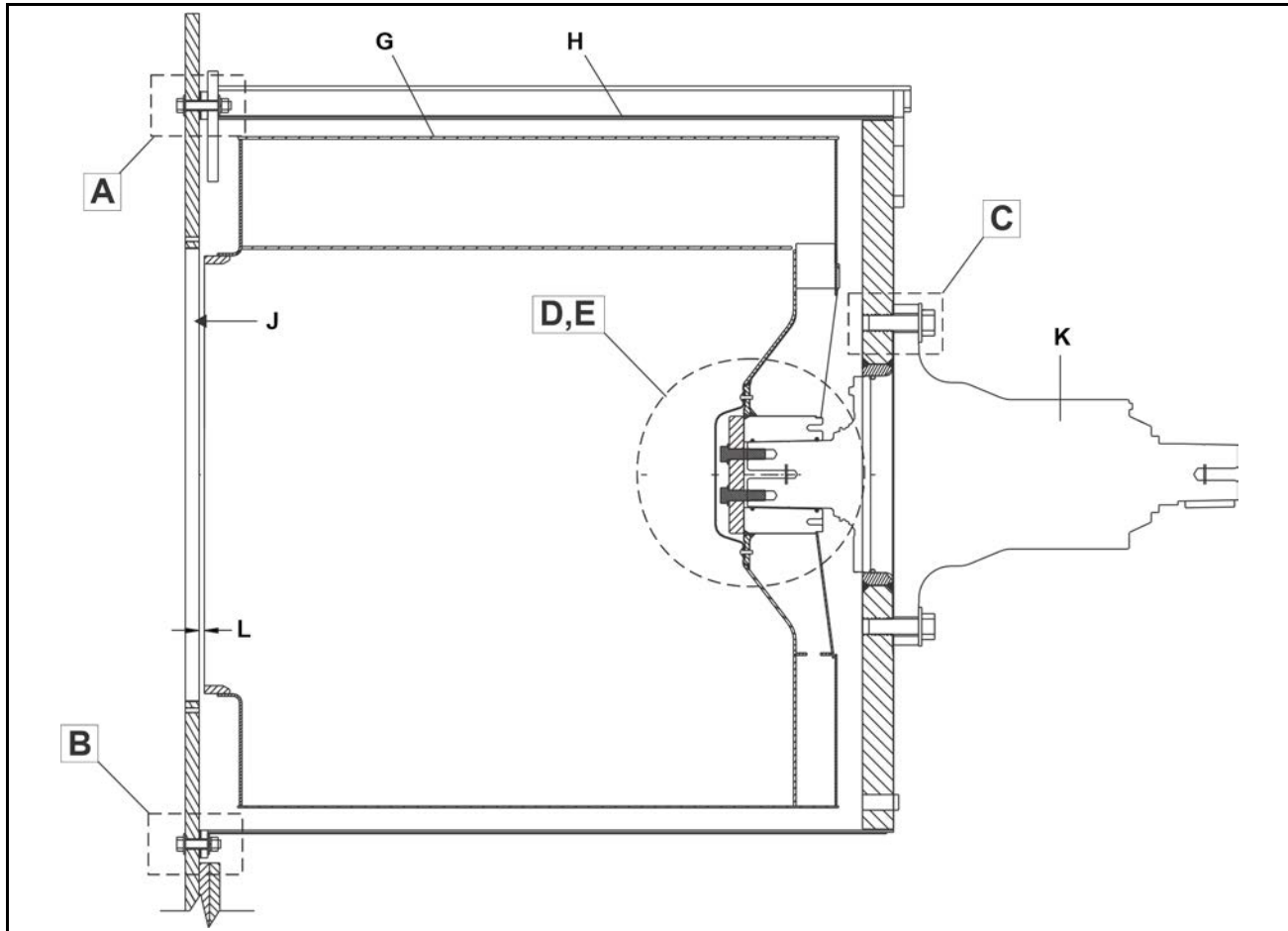

**Table 18. Parts List—Drive Components**

Find the assembly for your machine and the letter shown in the "Item" column. The components for your machine will show this letter or the word "all" in the "Used In" column. The numbers shown in the "Item" column are those shown in the illustrations.				
Used In	Item	Part Number	Description/Nomenclature	Comments
Components				
all	1	98MW850795	VBELT,SPB3550=1EA,MWF100	
all	2	98MW290700	MAIN PULLEY, MWF100	
all	3	98MW856029	MOTOR PULLEY MWF100	
all	4	98MW856024	TAPER LOCK, MWF100	
all	5	98CXE230CM	STRMACHKEY 3/8SQX2+1/2	
all	6	98CMCR0406	20HP 4P 220/380/440V/50HZ MWF100 CASTIC	

Cylinder and Bearing Installation

Figure 11. Cross section view



**Legend**

- A. Detailed view — Top connection between the shell front and the shell side sheet
- B. Detailed view — Bottom connection between the shell front and the shell side sheet
- C. Detailed view — Connection between the shell rear and the bearing housing
- D. Detailed view — Connection between the Pull-up plate and the Hub (outer bolts)
- E. Detailed view — Connection between the Pull-up plate and the Shaft (inner bolts)
- G. Cylinder
- H. Shell
- J. Shell front
- K. Bearing housing
- L. This dimension must be in this range: 0.3125 inches [8mm] — 0.375 [9.5mm].

# Cylinder and Bearing Installation

4 Sheet

4840F, MWF100, MWF125

Figure 12. Detailed views

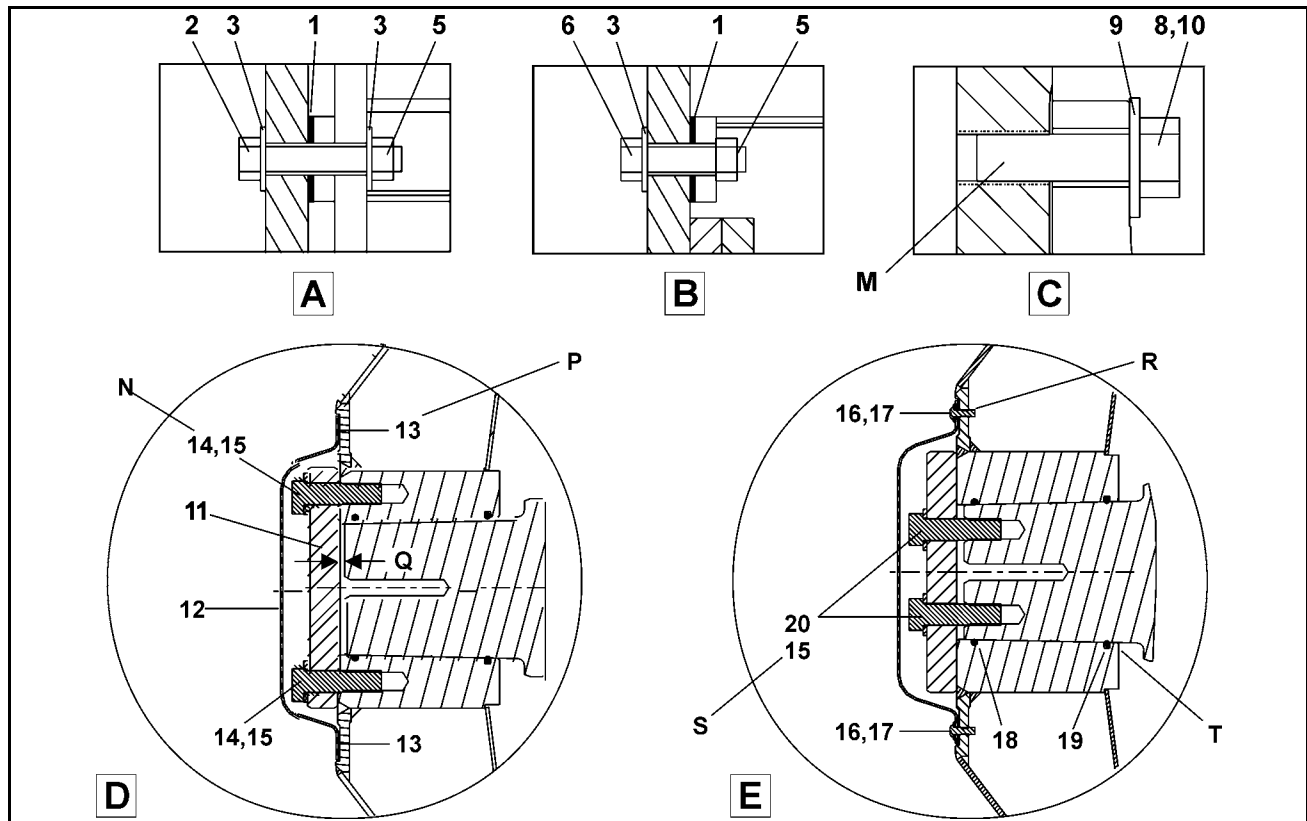

### Legend

- A. Top connection between the shell front and the shell side sheet
- B. Bottom connection between the shell front and the shell side sheet
- C. Connection between the shell rear and the bearing housing
- D. Connection between the Pull-up plate and the Hub (outer bolts)
- E. Connection between the Pull-up plate and the Shaft (inner bolts)
- M. Use thread lock compound Locktite 242. Tighten to 1475 FT. LBS.
- N. Use thread lock compound Locktite 242. Tighten items 14 and 15 to 413 FT. LBS. (4 instances).
- P. Apply silicone to the hub side of the gasket.
- Q. 0.25 inches [6.3mm].
- R. Use thread lock compound Locktite 242. Tighten items 16 and 17 to 36 IN. LBS. (18 instances).
- S. Use thread lock compound Locktite 242. Tighten items 20 and 15 to 413 FT. LBS. (4 instances).
- T. Apply oil to the o-rings before you assemble.

# Cylinder and Bearing Installation

4840F, MWF100, MWF125

**Figure 13. Shell plugs**

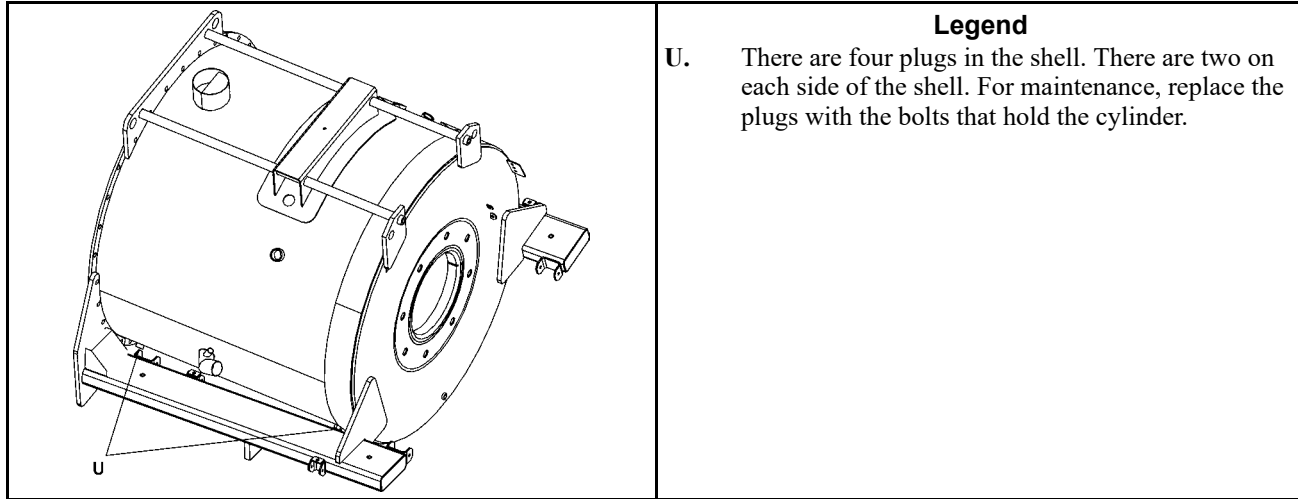

**Table 19. Cylinder and Bearing Installation**

Find the assembly for your machine and the letter shown in the "Item" column. The components for your machine will show this letter or the word "All" in the "Used In" column. The numbers shown in the "Item" column are those shown in the illustrations.				
Used In	Item	Part Number	Description/Nomenclature	Comments
<b>Assemblies</b>				
	A		REFERENCE	MWF100
	B		REFERENCE	4840F, MWF125
<b>Components</b>				
All	1	03 48053B	GSKT=53+1/2BC 4840F 1/8 THK	
A	2A	15B206	HEXCAPSCR M20-2.5X100, 8.8 ZINC	
B	2B	15K226FM	HEXCAPSCR M16X80, ZINC 8.8	
A	3A	15U283A	M20 FLATWASHER HARD	
B	3B	15U316M	FLTWASH D16 HARD HV200 D16 Z	
A	5A	15G240M	HEX NUT M20-2.5 ZINC	
B	5B	98CX773115	HEXNUT M16, ZINC	
A	6A	15B203	HEXCAPSCR M20-2.5X70 ZINC 8.8	
B	6B	98CX770164	HEXCAPSCR M16X70, ZINC8.8	
All	8	15K310M	HEXCAPSCR M30X100 CLS 10.9 Z	
All	9	15U600	FLTWASH 1+1/4 HARD ASTM F436	
All	10	20C007G	THDLOCKSEAL LCT24231 RMUBL50CC	
A	11	X2 21916	CYL PULL-UP PLATE, 4840F7	
B	11	98MW90720	CYL PULL-UP PLATE, MWF100	
All	12	X2 21917	COVER=CYL HUB, 4840F7 MACH	
All	13	02 21918	GASKET= CYL HUB COVER, 4840F7	
All	14	15B201B	M30-3.5X100 CLS10.9 HEX HD CAP SCREW ZINC	

**Cylinder and Bearing Installation**

4 Sheet

4840F, MWF100, MWF125

**Table 19 Cylinder and Bearing Installation (cont'd.)**

Find the assembly for your machine and the letter shown in the "Item" column. The components for your machine will show this letter or the word "All" in the "Used In" column. The numbers shown in the "Item" column are those shown in the illustrations.				
Used In	Item	Part Number	Description/Nomenclature	Comments
All	16	15U137	FLTWSHR M6-1 18-8 SS	
All	17	15K032MS	BUTSOKCAP SCR M6*20 SS	
All	18	60C155V	ORING 4.75ID3/16CS VITON75#351	
All	19	60C157V	ORING 4+7/8ID 3/16CS VITON-352	
All	20	15B201A	M20-2.5X60 CLS10.9 HEX HD CAP SCREW ZINC	

**Bearing Assembly 4840F, MWF100, MWF125**

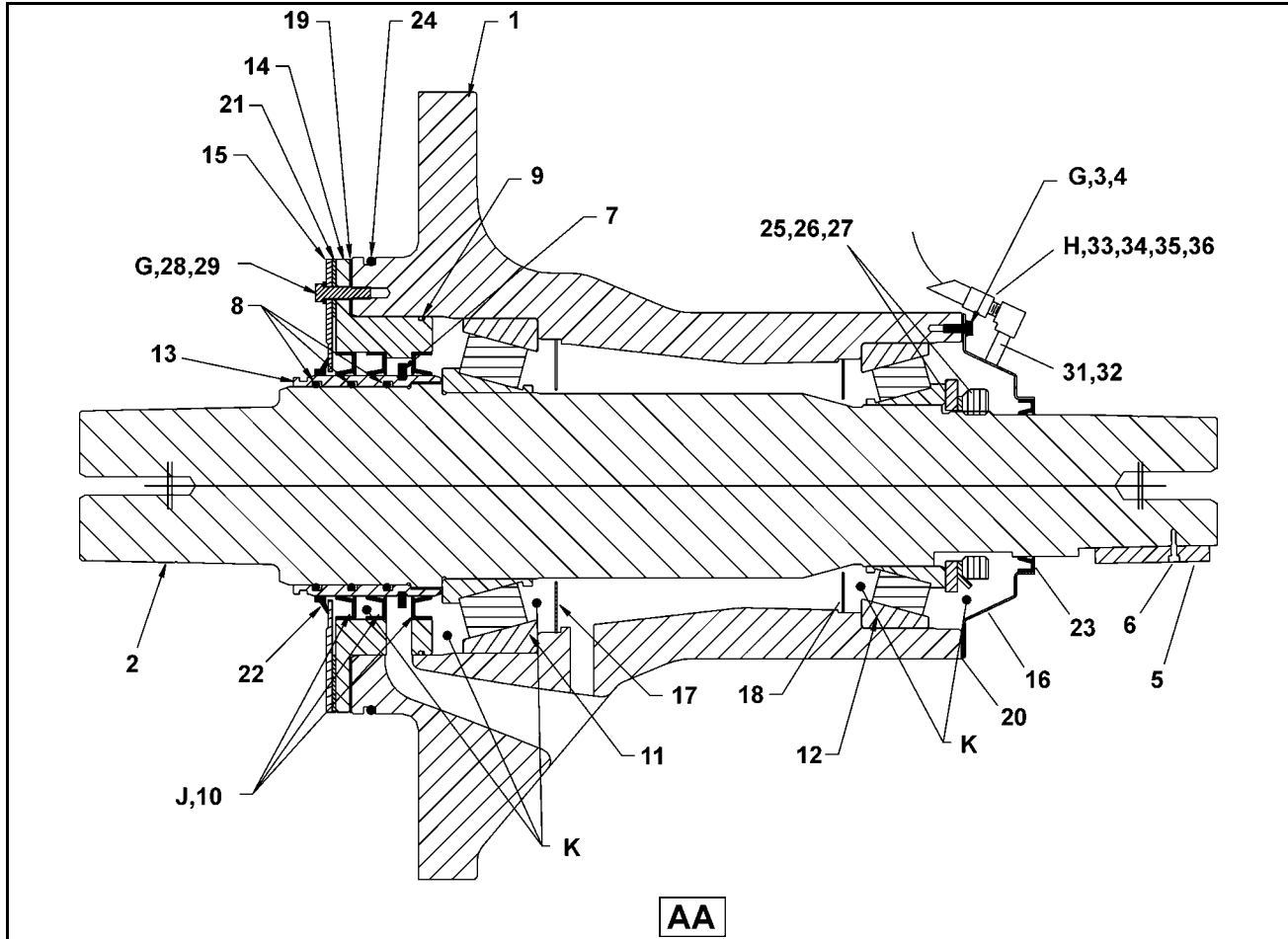

- G. Use Loctite 242 torque to 34 FT. LBS.
- H. Grease inlet for the rear bearing
- J. When you install new seals, make sure that they point in the direction shown. The installation sequence: Install one seal into the rear of the seal holder. Install the seal holder. Install the two remaining seals.
- K. Fill this space with grease.



**Bearing Assembly 4840F, MWF100, MWF125**

6 Sheet

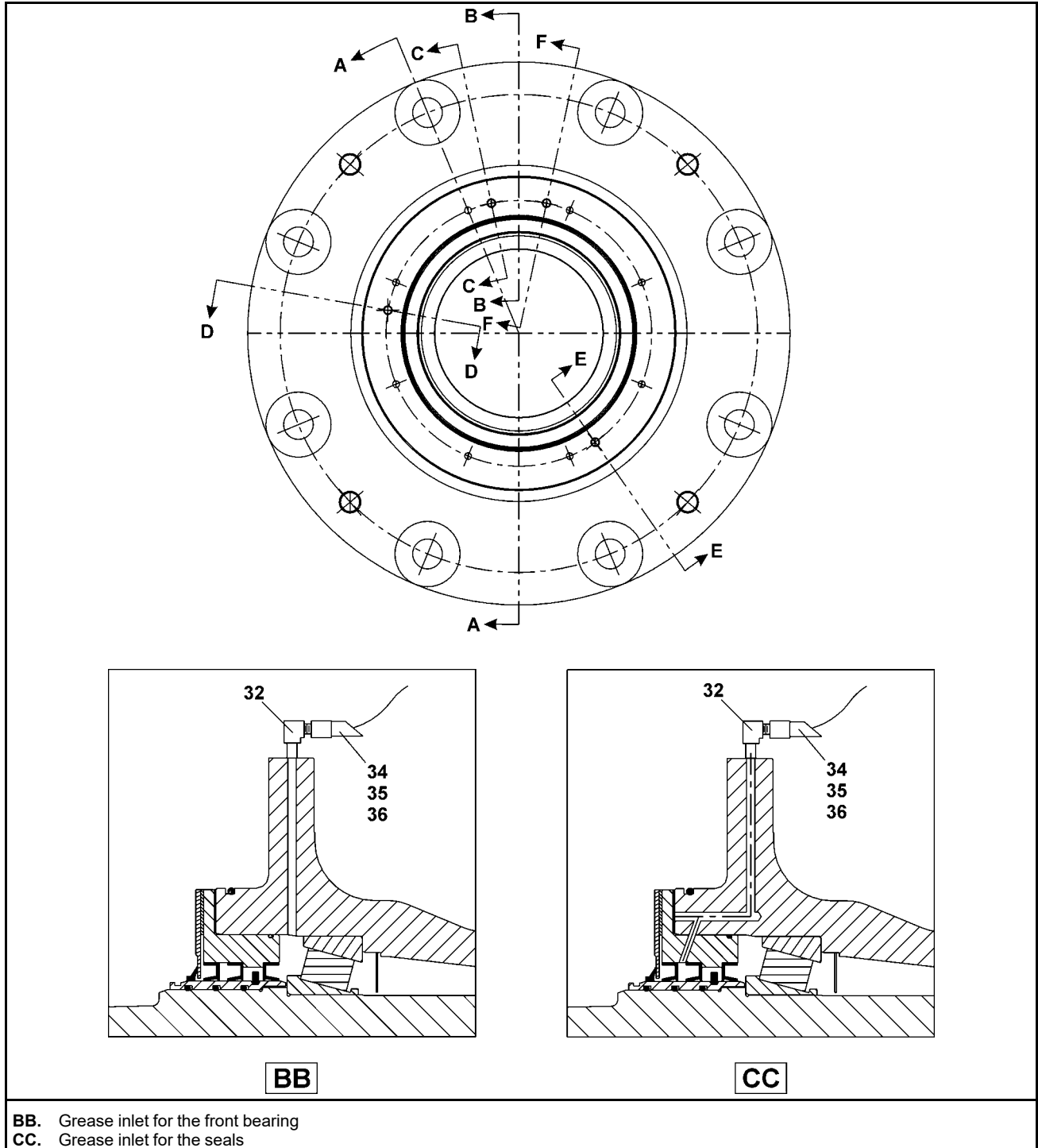

Bearing Assembly 4840F, MWF100, MWF125

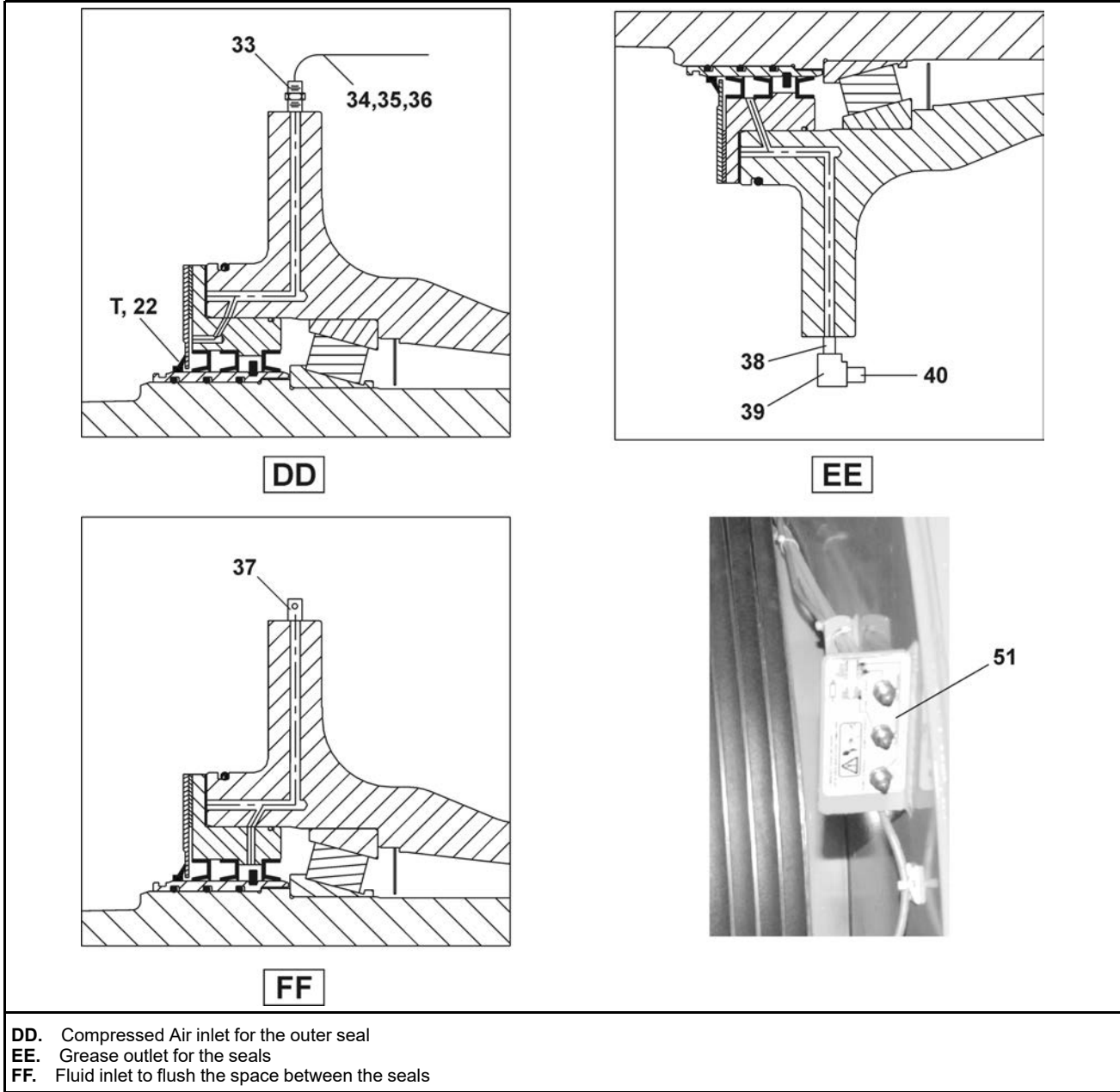

**Bearing Assembly 4840F, MWF100, MWF125**

6 Sheet

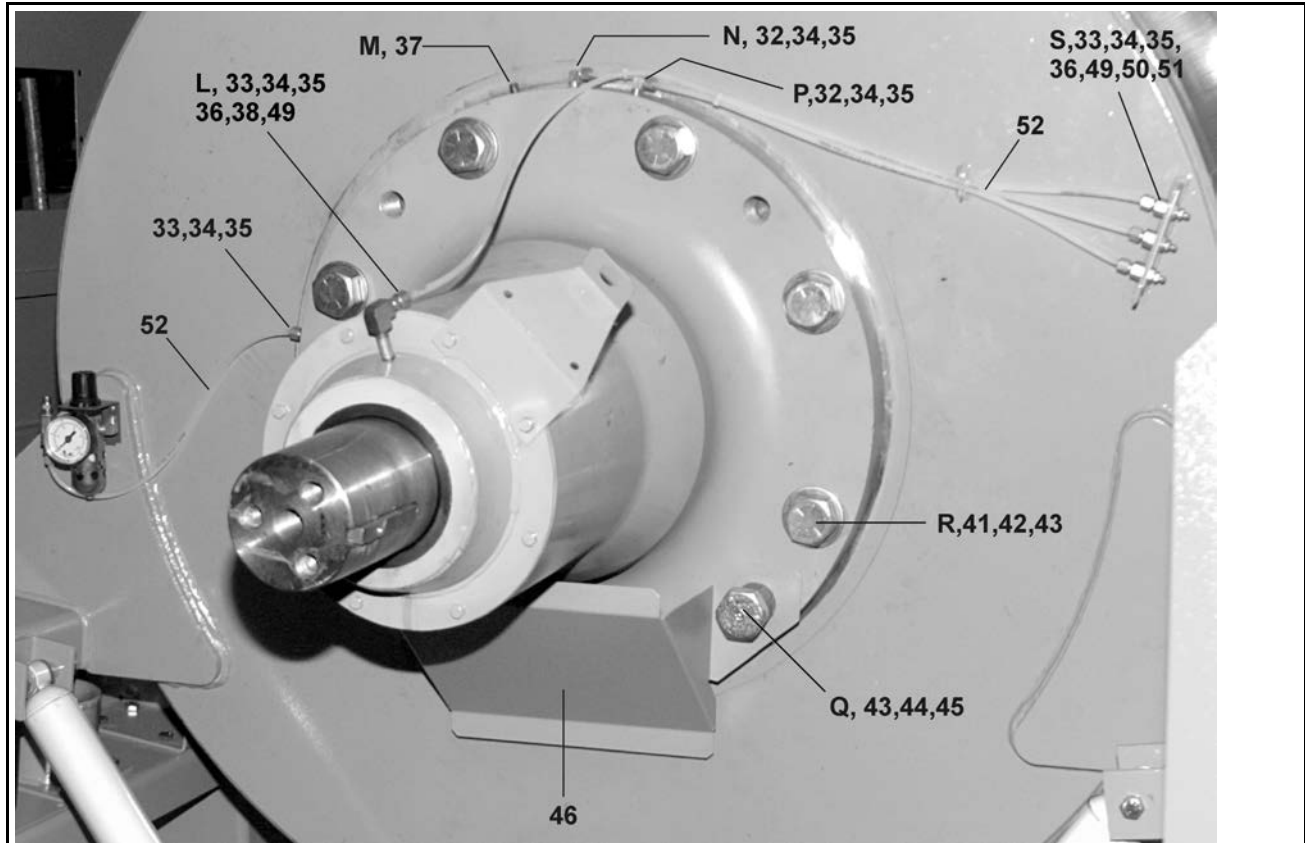

- L. Grease inlet for the rear bearing
- M. Fluid inlet to flush the space between the seals
- N. Grease inlet for the front bearing
- P. Grease inlet for seals
- Q. 2 instances
- R. 8 instances
- S. 3 instances
- T. Outer seal

**Table 20. Bearing Assembly 4840F, MWF100, MWF125**

Used In	Item	Part Number	Description/Nomenclature	Comments
<b>Assemblies</b>				
	A	98CMCR4811	BEARING ASSEMBLY — REFERENCE	4840, MWF125
	B	98MW4801	BEARING ASSEMBLY — REFERENCE	MWF100
<b>Components</b>				
A	1	98CMCR4830	4840F BEARING HOUSING, METRIC	
B	1	98MW4810	MWF100 BEARING HOUSING	
A	2	98CMCR4831	4840F MAIN SHAFT, METRIC	
B	2	98MW4811	MWF100 MAIN SHAFT	
	3	15K032MS	BUTSOKCAP SCR M6*20 SS	

## Bearing Assembly 4840F, MWF100, MWF125

6 Sheet

Table 20 Bearing Assembly 4840F, MWF100, MWF125 (cont'd.)

Used In	Item	Part Number	Description/Nomenclature	Comments
	4	15U137	FLTWSHR M6-1 18-8 SS	
	5	153E232	SQMACHKEY 3/8X3/8X3+3/4	
	6	15N102MS	FLATMACSCR M5X10 SS	
	7	02 21817	SLINGER=BRG FRNT SEAL,4840F	
A	8	60C160DB	ORING 6.25ID3/16CS BUNA70 -362	
A	8	60C160DV	ORING 6.25ID3/16CS VITON70#362	VITON
A	9	60C275	ORING 10.5ID 1/8CS BUN70-275	
A	9	60C275V	ORING 10.5ID 1/8CS VITON-#275	VITON
B	9	60C173A	ORING 8.484ID .139CS BUN70	
A	10	24S148	SEAL 7.0X8.5X.625#07009304LUPN	
A	10	24S148V	SEAL 7.0X8.5X.625#07009304LUPV	VITON
B	10	24S140	SEAL 5.75"x7.0"x.625"LUP	
A	11A	54A986	TAPEROLBRG SKF#32230J2 SET	
B	11B	98CX830136	TAPEROLBRG NTN 4T- HH224346/HH224310	
A	12A	54A987	TAPEROLBRG SKF#32226J2 SET	
B	12B	54AT101190	TIMK HH221449/HH221410=4"BORE	
A	13A	X2 21802	SHAFT SEAL SLEEVE, 4840F7	
B	13B	98MW90405	SHAFT SEAL SLEEVE, MWF100	
A	14A	X2 21803	MACH=FRONT SEAL HLDR, 4840F7	
B	14B	98MW90403	MACH=FRONT SEAL HLDR, MWF100	
A	15A	X2 21804	PLATE=EXCLUDER SEAL, 4840F7	
B	15B	98MW90409	PLATE=EXCLUDER SEAL, MWF100	
A	16A	02 21805	REAR SEAL HOLDER, 4840F7	
B	16B	98MW90404	REAR SEAL HOLDER, MWF100	
A	17A	02 21806	FRONT GREASE SHIELD, 4840F7	
B	17B	98MW90407	FRONT GREASE SHIELD, MWF100	
A	18A	02 21807	REAR GREASE SHIELD, 4840F7	
B	18B	98MW90408	REAR GREASE SHIELD, MWF100	
A	19A	02 21810	GASKET=FRNT SEAL HLDR,4840F7	
B	19B	98MW90406	GASKET=FRNT SEAL HLDR, MWF100	
A	20A	02 21811	GASKET=REAR SEAL HLDR,4840F7	
B	20B	98MW90411	GASKET=REAR SEAL HLDR, MWF100	
A	21	02 21812	GASKET=EXCLUDER SEAL, 4840F7	
B	21	98MW90406	GASKET=FRNT SEAL HLDR, MWF100	
A	22	24S146	SEAL 7.0X8.0X.437 TYPE SSW NIT	
A	22	24S146V	SEAL 7.0X8.0X.437 TYPE SSW VIT	VITON

## Bearing Assembly 4840F, MWF100, MWF125

6 Sheet

Table 20 Bearing Assembly 4840F, MWF100, MWF125 (cont'd.)

Used In	Item	Part Number	Description/Nomenclature	Comments
B	22	24S141	SEAL EXCLUDER 10817 H1L5 SSW STYLE 5.75" X 7.875" X .625"	
A	23A	24S114	SEAL 4.5X5.5X.50 JM# 9170 LUP	VITON
A	23C	24S114V	SEAL 4.5X5.5X.50 JM#9170LUP-V	
B	23B	98CX850453	SEAL WA95 125 12	
A	24A	60C190	ORING 14.0ID 1/4CS BUNA70-457	
A	24B	60C190D	ORING 14.0ID 1/4CS VITON -457	VITON
B	24C	60C177	ORING 10.975 ID .275 CS BUNA 70	
A	25A	56AHN24	AN24 BEARING LOCKNUT	
B	25B	98MW90412	BEARING LOCKNUT, MWF100	
A	26A	56AHW124	TW124 BEARING LOCKWASHER	
B	26B	98CX773812	BEARING LOCKWASHER, MWF100	
A	27A	56ATW24	TONGUE WASH TM K91524 FOR AN24	
B	27B	98MW90420	TONGUE WASH, MWF100	
B	28B	15K117MS	HXCAPSCR M10X35 SS 8.8	
A	29A	15U260	LOCKWAASHER MEDIUM 3/8 SS18-8	
B	29B	15U276S	FLTWSHR.475ID.656OD 22GA 18-8S	
All	30	20C003A	ADHESIVE BLK MAX 1OZ LOC#38050	
All	32	98CX932503	PIPE FITTING, 90 DEGREE, .25X1/8 BSP	
All	33	98CX932801	PIPE FITTING, 6.5X1/4 BSP	
All	34	98CX961460A	SLEEVE DELRIN 6MM	
All	35	98CX961460	TUBE INSERT 4MM	
All	36	98CX931701	HEXBUSH, 1/4X1/8 BRASS BSP	
All	37	5SP0CFESSV	NPTPLUG1/8SQLDBLKSTL LVENT125	
All	38	5SCC0ESFH	NPT HALFCOUP 1/4 304SS 150#	
All	40	54M029	RELIEFFIT 1/8STR ALEMITE 47200	
All	41	15K310M	HEXCAPSCR M30X100 CLS 10.9 Z	
All	42	15U600	FLTWASH 1+1/4 HARD ASTM F436	
All	43	20C007G	THDLOCKSEAL LCT24231 RMUBL50CC	
All	44	15K253H	HEXCAPSCR M24-3.0X40, 8.8 ZINC	
All	45	15U393	FLTWASH 1" HARD ASTM F436	
All	46	02 21818	BEARING DRIP SHIELD, 4840F	
All	49	15U281A	WASHER=CLIPPED 1/2 ID .06THK	
All	50	98CX961708	GREASE FITTING, 1/8BSP ZINC	
All	51	01 10025Y	NPLT:BEARING&SEAL LUB-48"MACH	
All	52	98CX910823	FLEXIBLE TUBING, 4X6MM OD	

**Air Injection Components**

**Detailed Views**

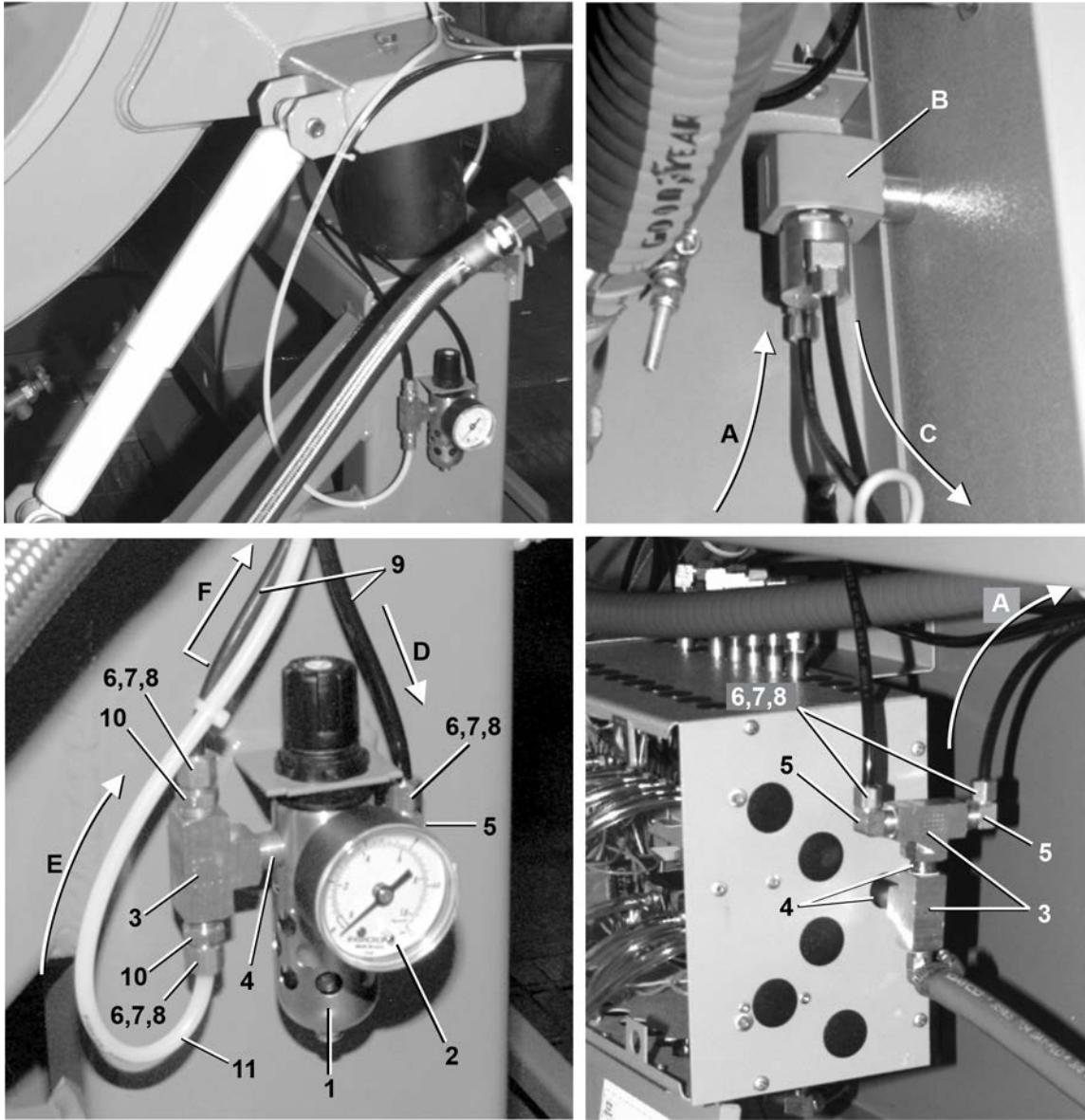

**Legend**

- A** . . . Compressed air to the bearing seal coil
- B** . . . Bearing seal coil
- C** . . . Compressed air to the pressure regulator
- D** . . . Compressed air from the bearing seal coil
- E** . . . Compressed air to the bearing
- F** . . . Compressed air to the bearing pressure switch

# Air Injection Components

2 Sheets

**Figure 14. Air Flow in the Bearing Housing**

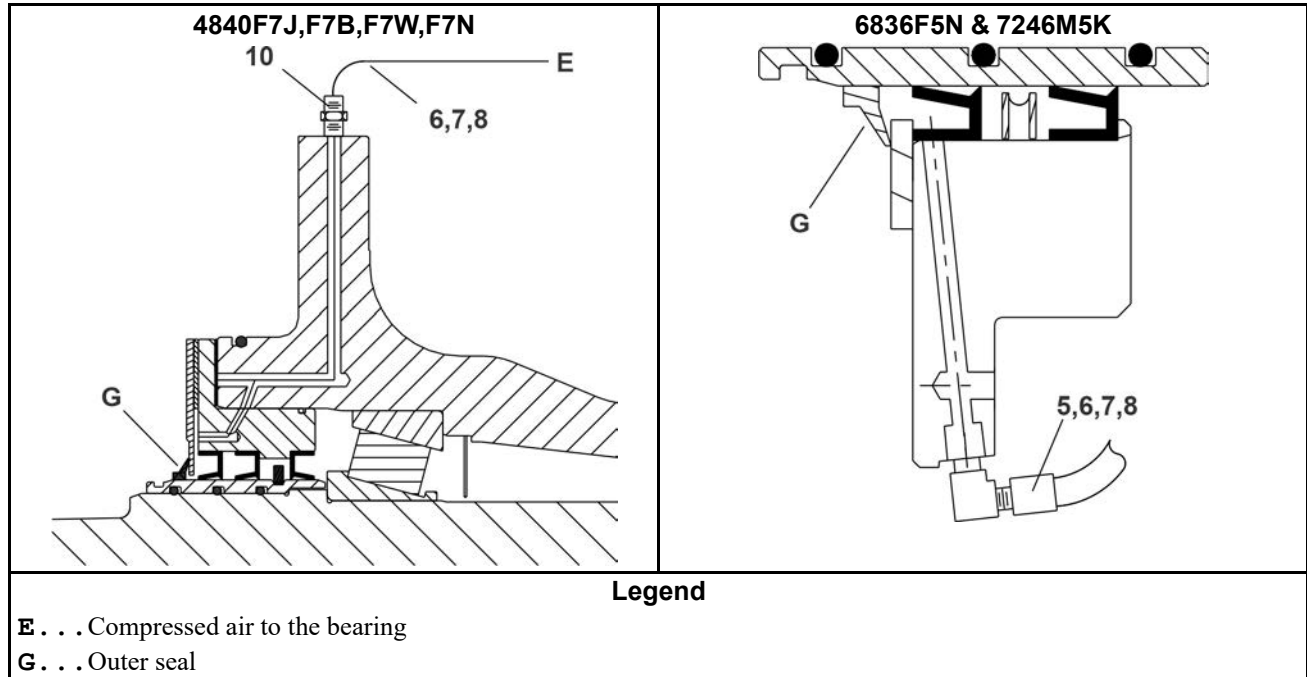

**Table 21. Parts List—Air Injection Components**

Find the assembly for your machine and the letter shown in the "Item" column. The components for your machine will show this letter or the word "all" in the "Used In" column. The numbers shown in the "Item" column are those shown in the illustrations.				
Used In	Item	Part Number	Description/Nomenclature	Comments
Reference Assemblies				
	A	AIR58003	AIR INJECT ASSY=BNG HOUSE	
Components				
all	1	96J019G	1/4"FILTERREG 0-60PSI	
all	2	30N095	PRESSGAUGE 1/8"BACKCN.0-15PSI WIKA 50104951 SERIES 111.12 2"	
all	3	51V015	TEE 1/4 FGDBRASS 101T7-444	
all	4	5N0ECLSBE2	NPT NIP 1/4XCLS TBE BRASS 125#	
all	5	53A031B	BODY-EL90MALE.25X1/8 #269C-42B	
all	6	53A059A	NUT 1/4"BR.HOLYOKE AND #61A-4	
all	7	53A500	SLEEVE DELRIN 1/4"OD#60PT-4	
all	8	53A501	TUBE INSERT .163"OD #63PT-4-40	
all	9	60E004TE	1/4"OD X .170"ID NYL(BLK)TUBING	
all	10	53A005B	BODYMALCON1/4X1/8COMP #B68A-4A	
all	11	60E004TC	TUBING NYL(NAT)1/4"ODX.17ID	

# 5 Suspension



This page intentionally blank

# Suspension

2 Sheets

MWF100J7, MWF100Z7, MWF100C7, MWF100Y7; MWF125J7, MWF125Z7, MWF125C7, MWF125Y7

Figure 15. Suspension Components

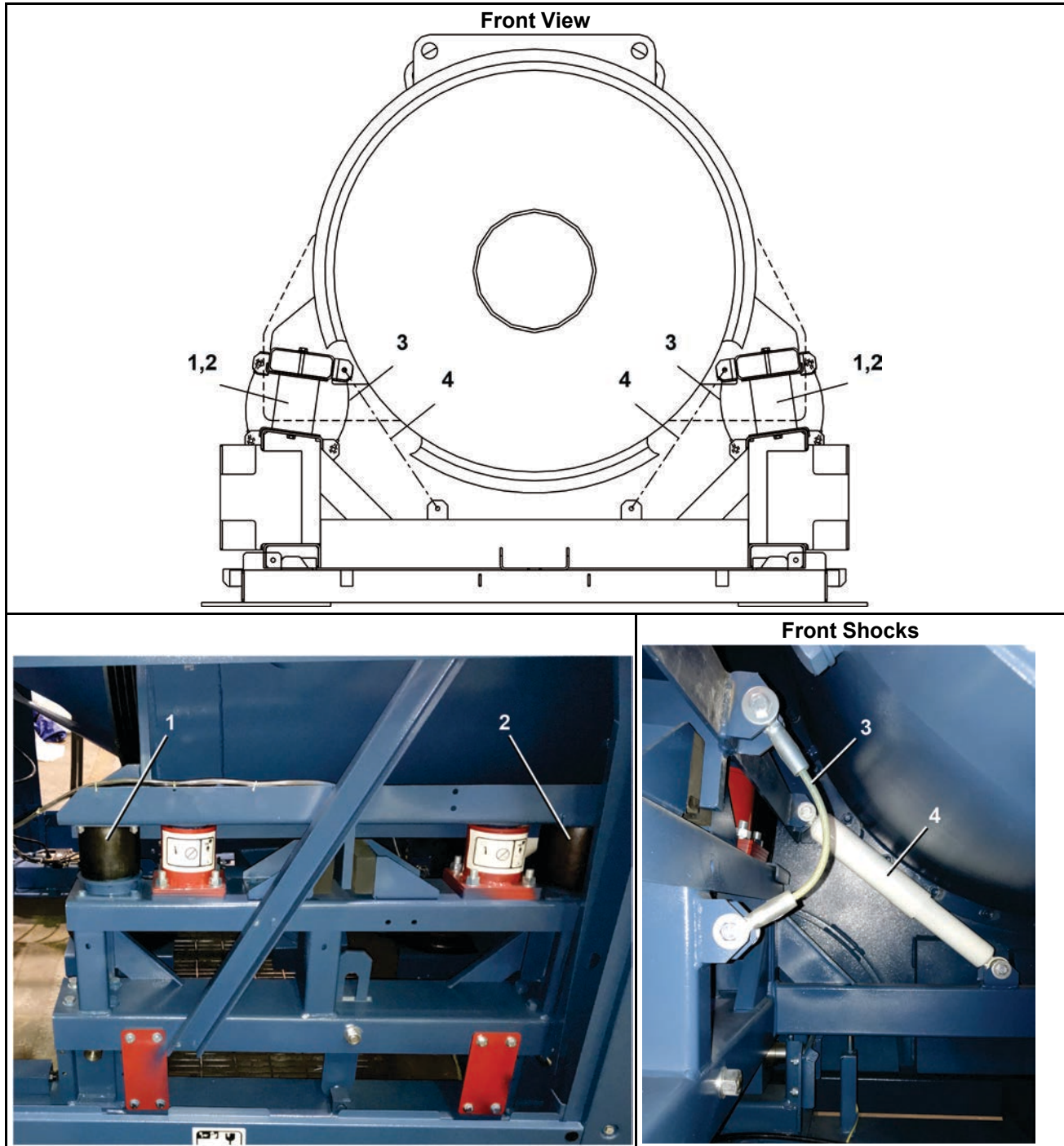

# Suspension

2 Sheets

MWF100J7, MWF100Z7, MWF100C7, MWF100Y7; MWF125J7, MWF125Z7, MWF125C7, MWF125Y7

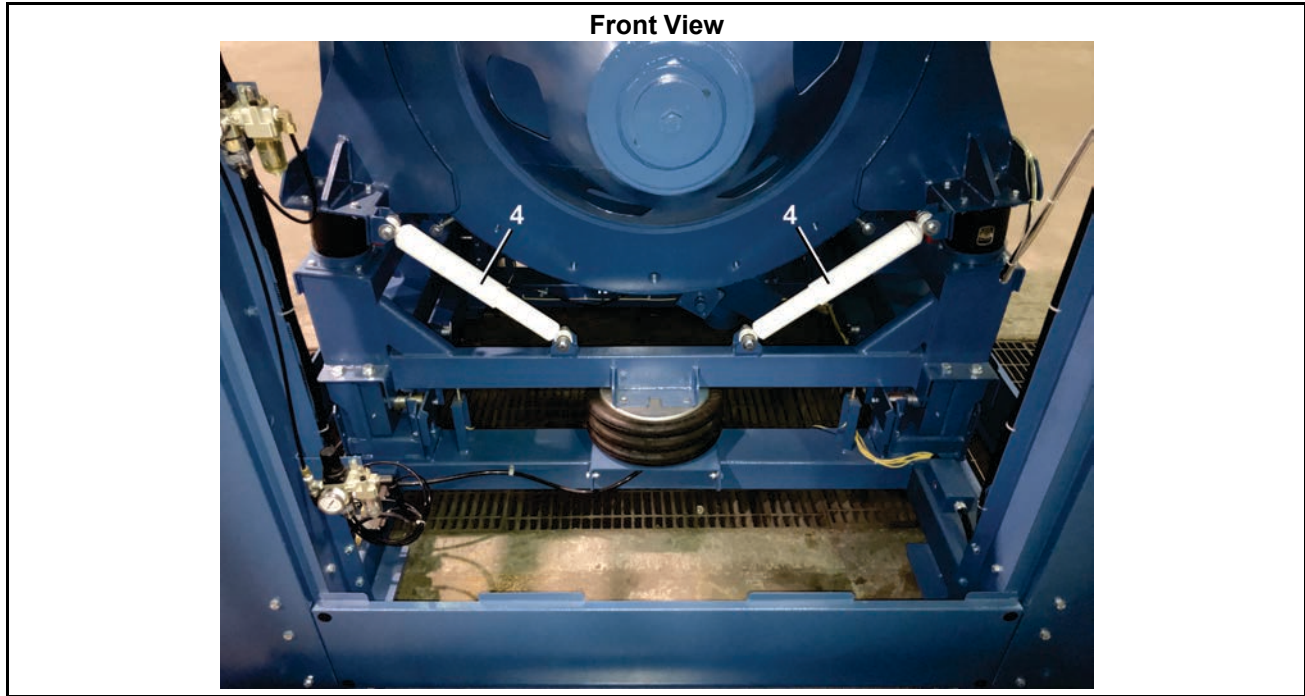

**Table 22. Parts List—Suspension**

Find the assembly for your machine and the letter shown in the "Item" column. The components for your machine will show this letter or the word "all" in the "Used In" column. The numbers shown in the "Item" column are those shown in the illustrations.				
Used In	Item	Part Number	Description/Nomenclature	Comments
Reference Assemblies				
	A			MWF100
	B			MWF125
Components				
A	1	60B136	MM SPRG 4.5X2X6 F#W223580178	
B	1	60B134	MM SPRG 4.5X1X7 FIRESTONE#W223580091	
all	2	60B133	MM SPRG 5X1X7 FIRESTONE#W223580064	
all	3	27A969	CABLE ASSY SAVA#205801	
all	4	60BS6832	SHOCK ABSORBR GABRIEL #65488440X	

# 6 Door Assemblies

This page intentionally blank

**Manual Door**

6 Sheets

MWF100C7, MWF100Y7, MWF100J7, MWF100Z7; MWF125C7, MWF125Y7, MWF125J7, MWF125Z7

**Figure 16. Installation, Manual Door**

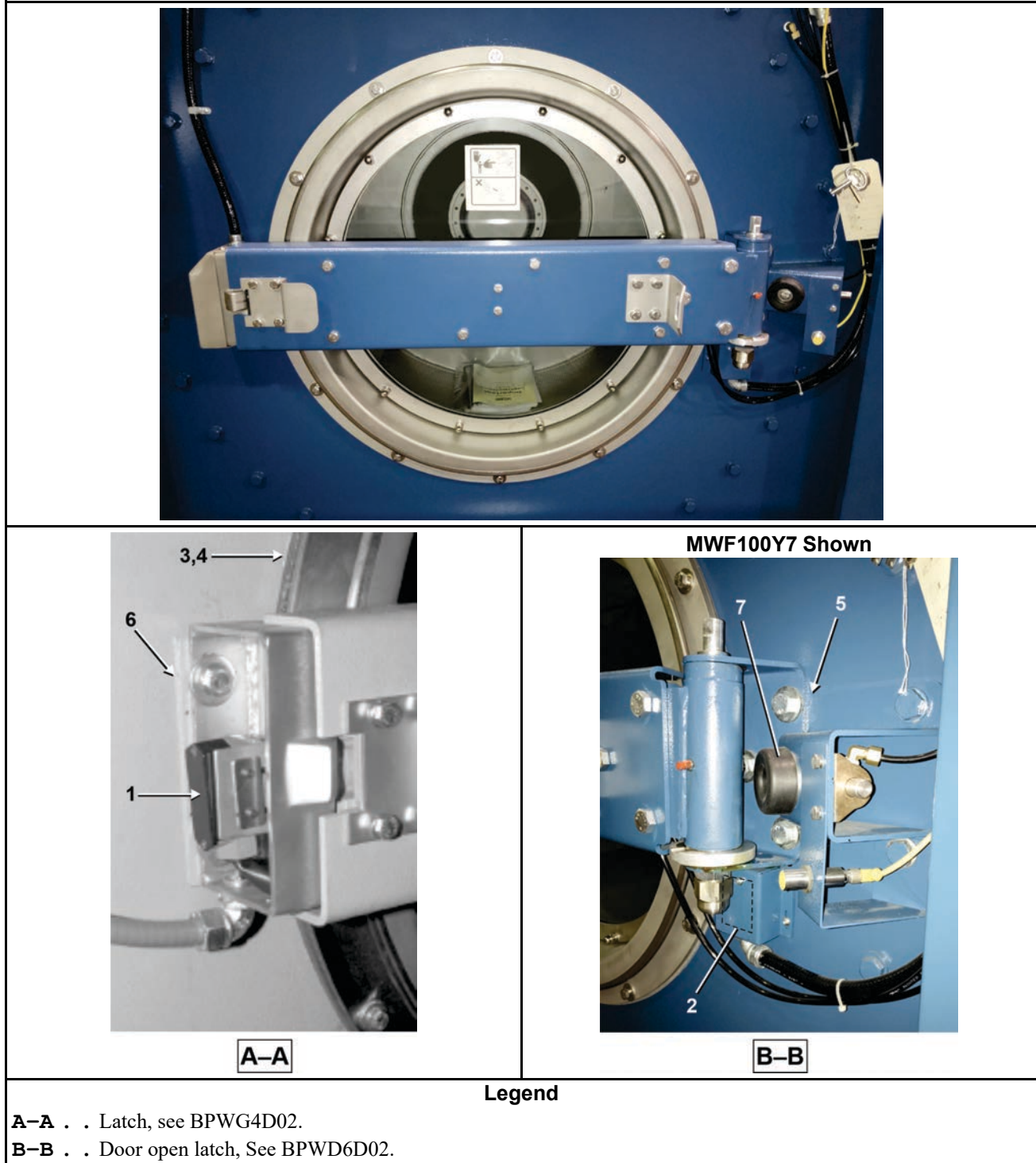



## Manual Door

6 Sheets

MWF100C7, MWF100Y7, MWF100J7, MWF100Z7; MWF125C7, MWF125Y7, MWF125J7, MWF125Z7

Figure 17. Adjust Door Position

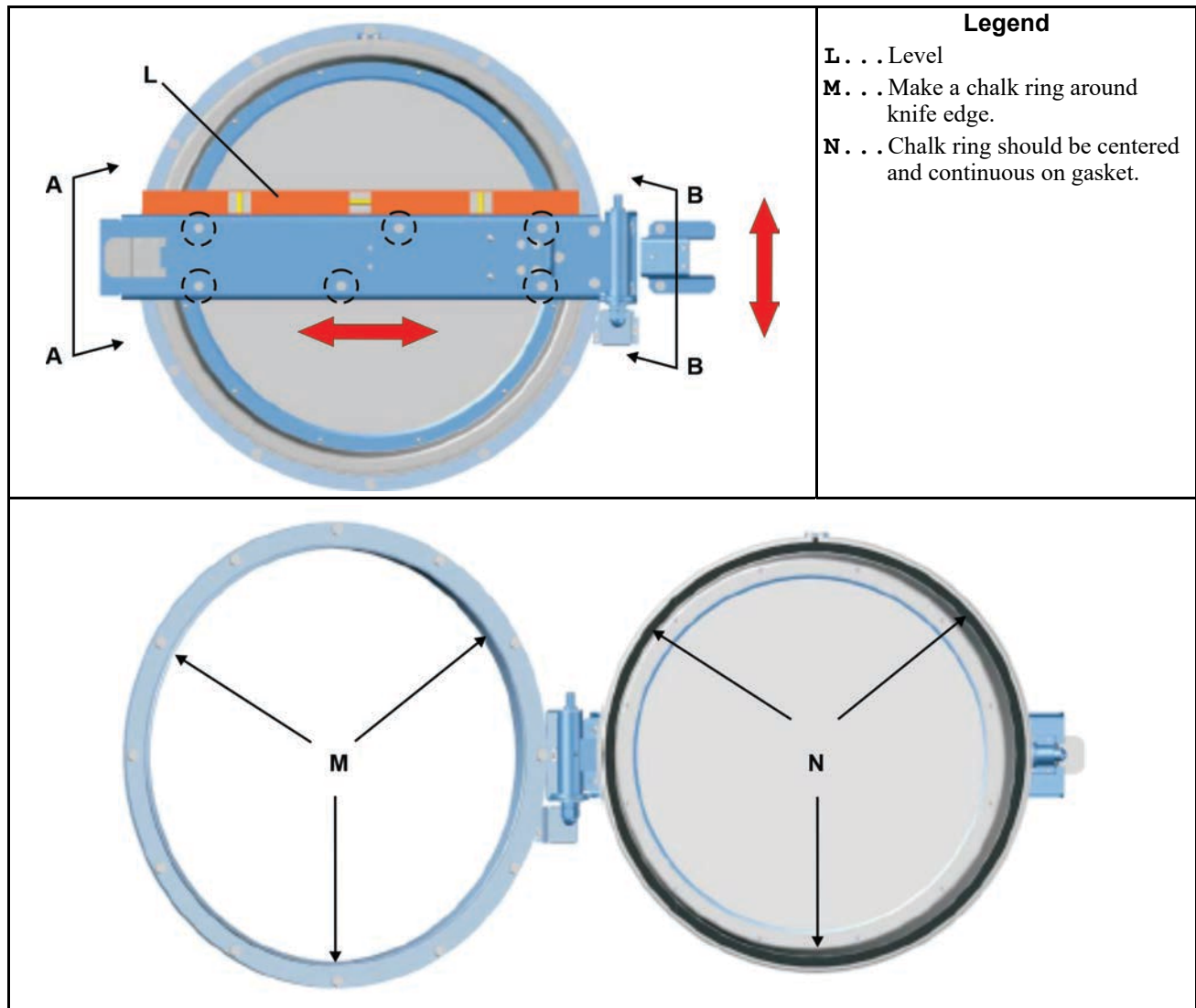

### Adjust Door Position

Install door with all shims and hardware. Do not tighten bolts.

1. Make sure the door channel is level.
2. Test that the door is centered to the door opening.
3. Check door position. Apply chalk around the knife edge ring. Close the door and activate the door seal. Open the door and check the impression on the door gasket. The chalk impression should be centered on the door gasket and a continuous circle.

**Manual Door**

6 Sheets

MWF100C7, MWF100Y7, MWF100J7, MWF100Z7; MWF125C7, MWF125Y7, MWF125J7, MWF125Z7

4. Adjust the position of the whole door. For left/right adjustments, slightly loosen the bolts shown circled in [Figure 17, page 73](#) and adjust door with a rubber or leather mallet. For vertical adjustment, slightly loosen hinge bolts and adjust door.
5. Recheck door position.
6. When the door is centered, adjust the door striker to match the door. It should have the same gap top and bottom.
7. Tighten door bolts.

**Figure 18. Adjust Door Position**

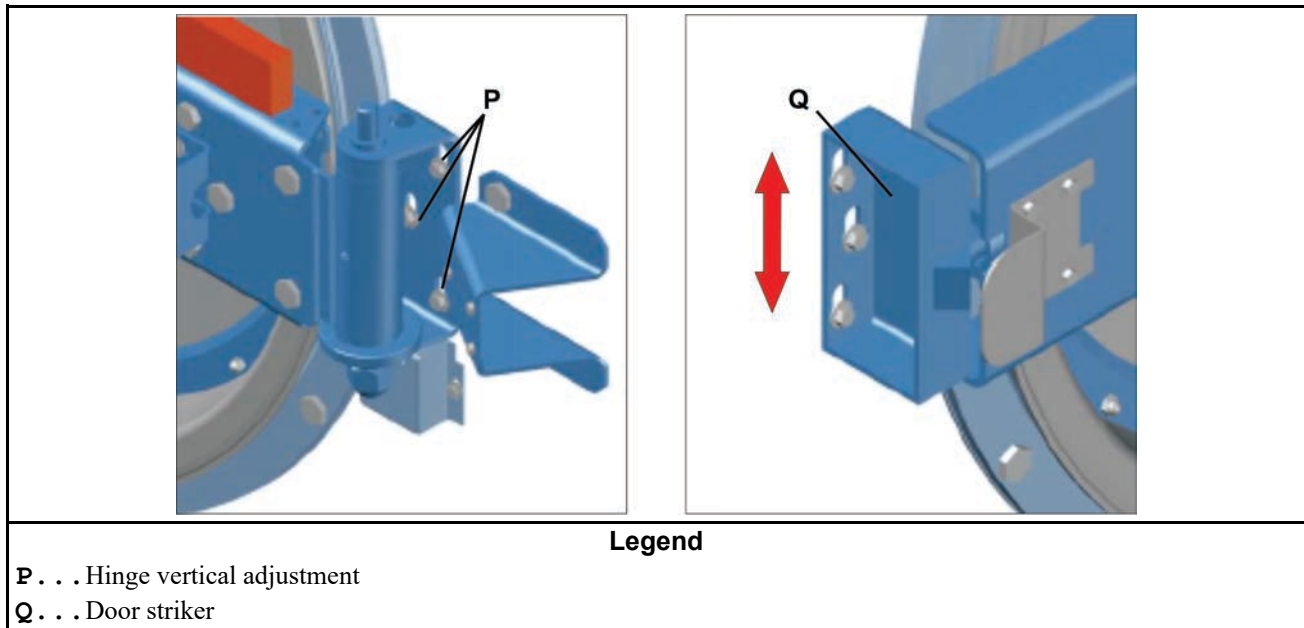



# Manual Door

6 Sheets

MWF100C7, MWF100Y7, MWF100J7, MWF100Z7; MWF125C7, MWF125Y7, MWF125J7, MWF125Z7

Figure 19. Door Components

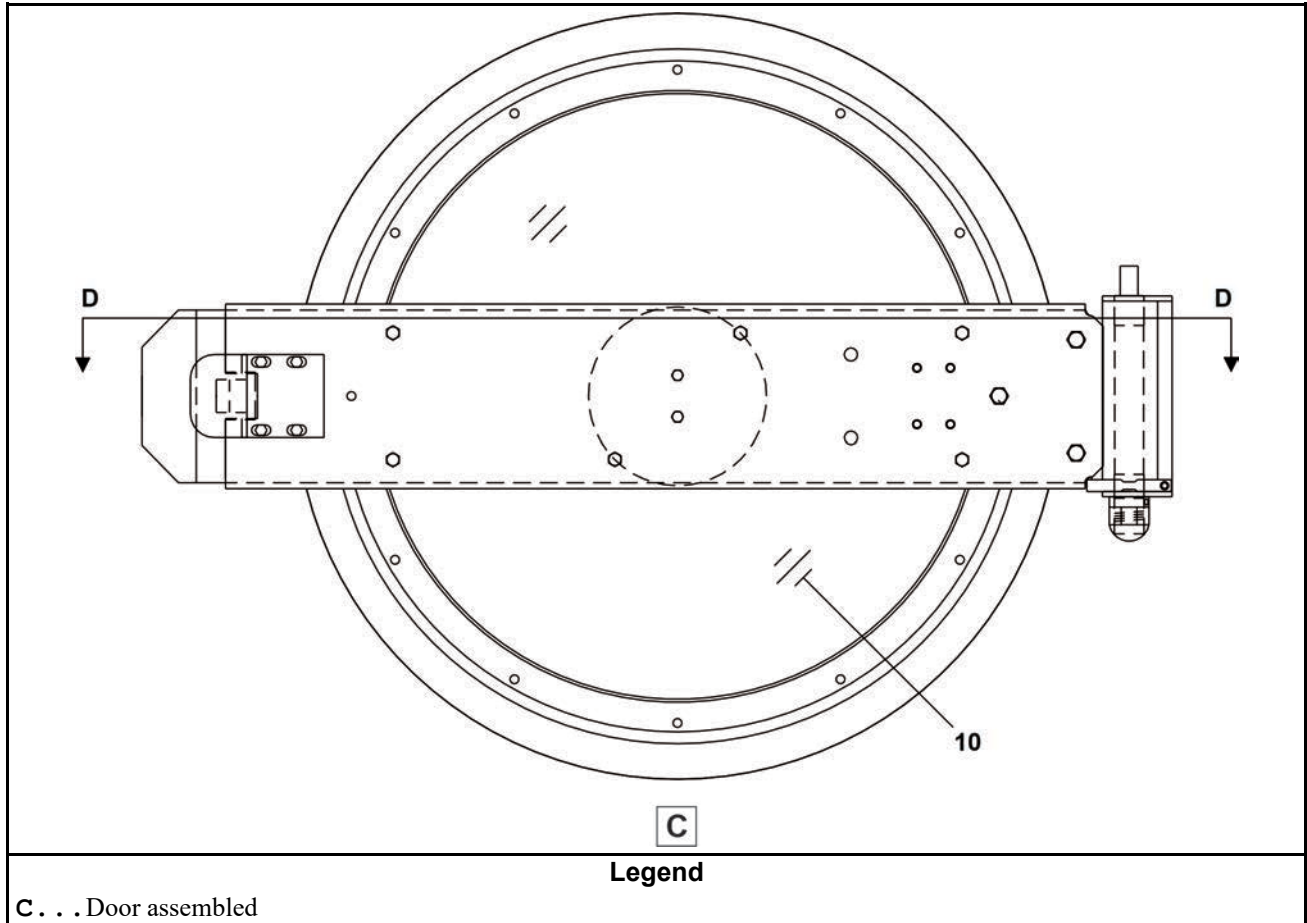

**Manual Door**

6 Sheets

MWF100C7, MWF100Y7, MWF100J7, MWF100Z7; MWF125C7, MWF125Y7, MWF125J7, MWF125Z7

**Figure 20. Door Components, Detail Views**

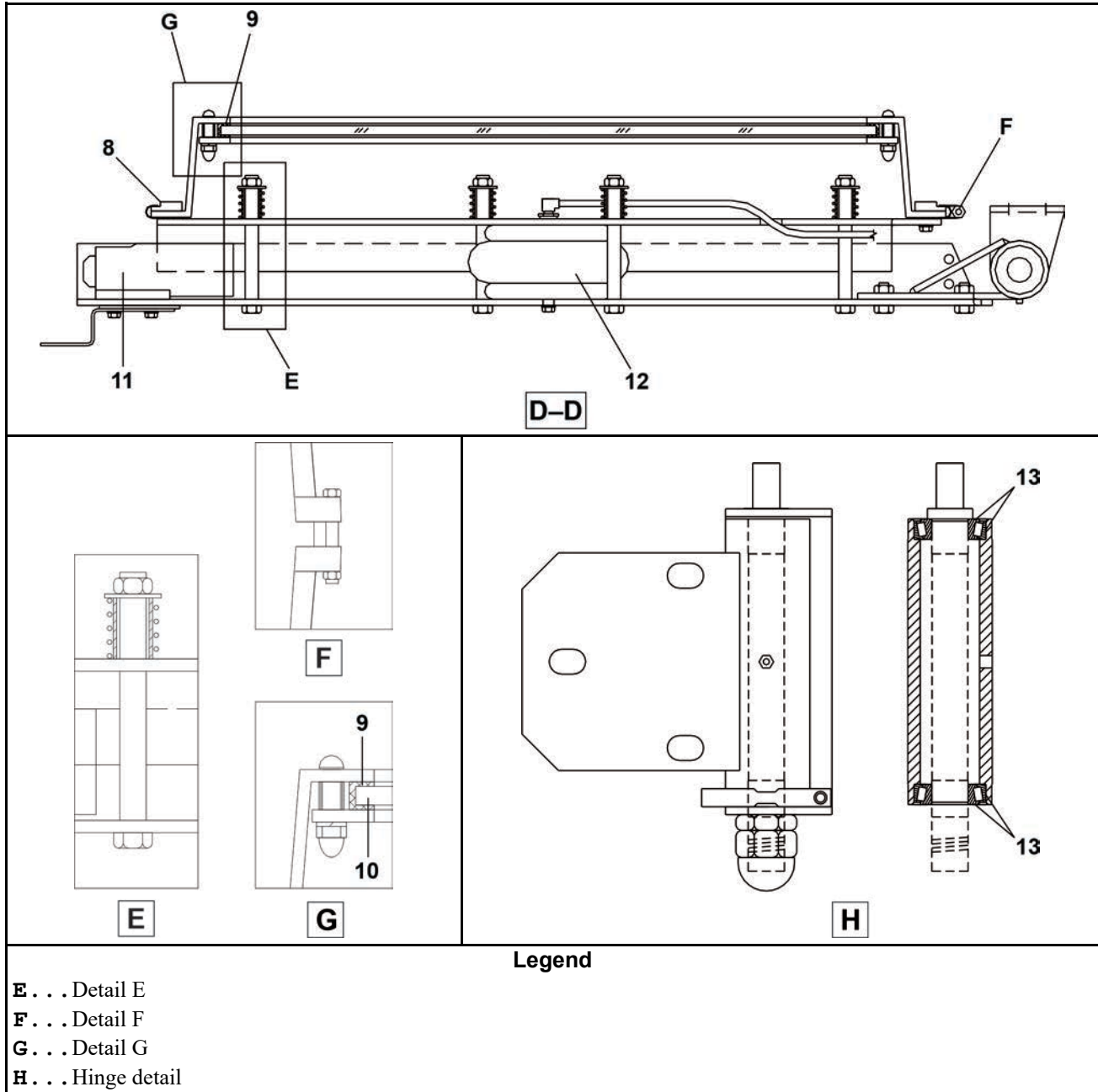

**Manual Door**

6 Sheets

MWF100C7, MWF100Y7, MWF100J7, MWF100Z7; MWF125C7, MWF125Y7, MWF125J7, MWF125Z7

**Table 23. Parts List—Manual Door**

Find the assembly for your machine and the letter shown in the "Item" column. The components for your machine will show this letter or the word "all" in the "Used In" column. The numbers shown in the "Item" column are those shown in the illustrations.				
Used In	Item	Part Number	Description/Nomenclature	Comments
Components				
all	1	98CMCR4819	DOOR LOCK SWITCH ASSY, 4840F CSM	
all	2	09RM01212S	CAPSW 12' 180DEG ROLLER SILVER	
all	4	98CF25026E	DOOR MTG RING GASKET=1/8", 4840F CSM	
all	5	98CF25170A	SHIM=HINGE BKT BOLT, 4840F CSM	
all	6	98CF25159W	SHIM=DOOR LATCH STRIKER, 4840F CSM	
all	7	98CX489258	RUBBER BUMPER, FOOT GUARD, 4840F CSM	
all	8	98CF25085A	DOOR GASKET, 4840F CSM	
all	9	98CF25083	DOOR GLASS GASKET, 4840F CSM	
all	10	98CF25013A	DOOR GLASS, 4840F CSM	
all	11	98CX15028	DOOR LATCH ASSY-DIVCYLS	
all	12	60B090	AIRMT S-131 1CONV.F#W013587731	
all	13	98CMCR4820	DOOR HINGE BEARING, 4840F CSM	

Door Latch

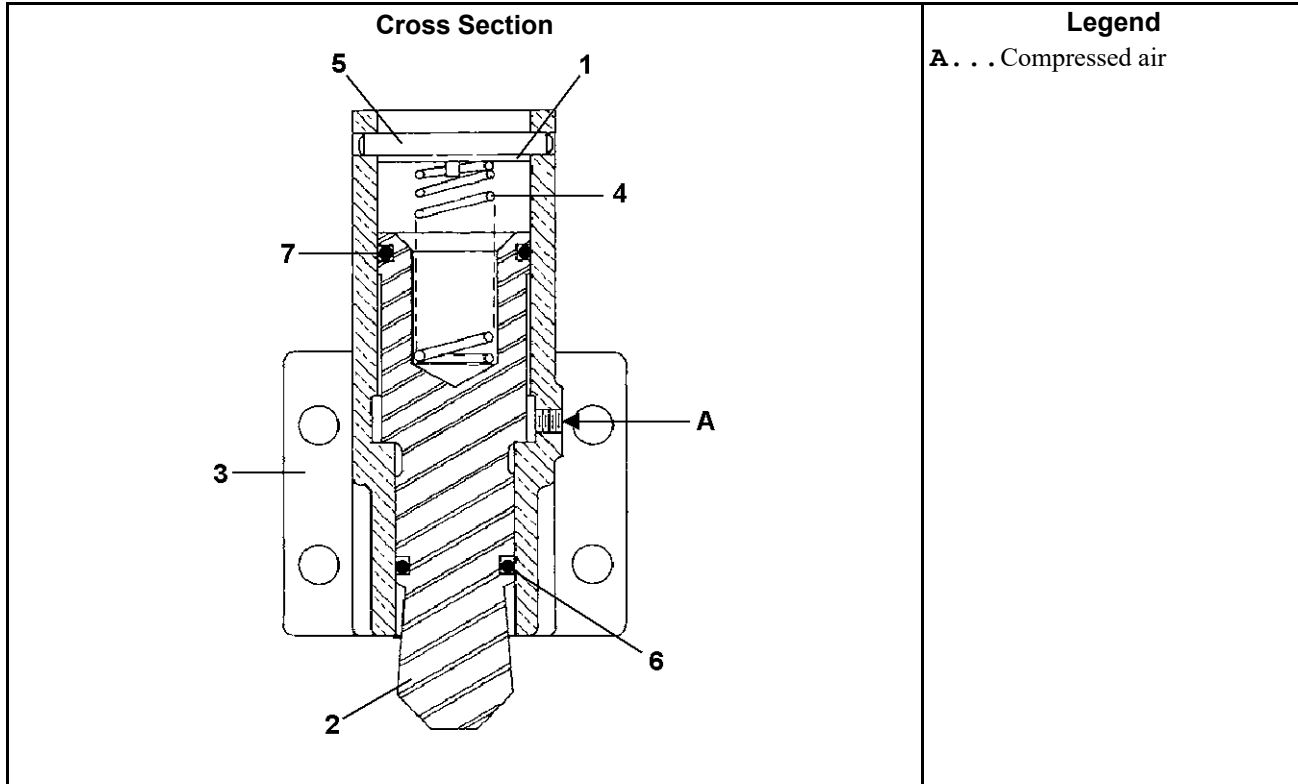

Table 24. Parts List—Door Latch

Find the assembly for your machine and the letter shown in the "Item" column. The components for your machine will show this letter or the word "all" in the "Used In" column. The numbers shown in the "Item" column are those shown in the illustrations.				
Used In	Item	Part Number	Description/Nomenclature	Comments
Reference Assemblies				
	A	SA 15 028	Assembly, Door latch	
Components				
all	1	02 15105	RETAINER RING	
all	2	02 15297	STRIKER	
all	3	02 15298	CYLINDER	
all	4	02 15836	SPRING	
all	5	15H090	PIN	
all	6	60C122	O-RING, 1"X1/8	
all	7	60C128	O-RING, 1+3/8X1/8	

BPWD6D02 / 2020356

BPWD6D02.1 0000305578 A.3 C.3 8/28/20, 4:54 PM Released

Door Latch

1 Sheet

Figure 21. Door Latch

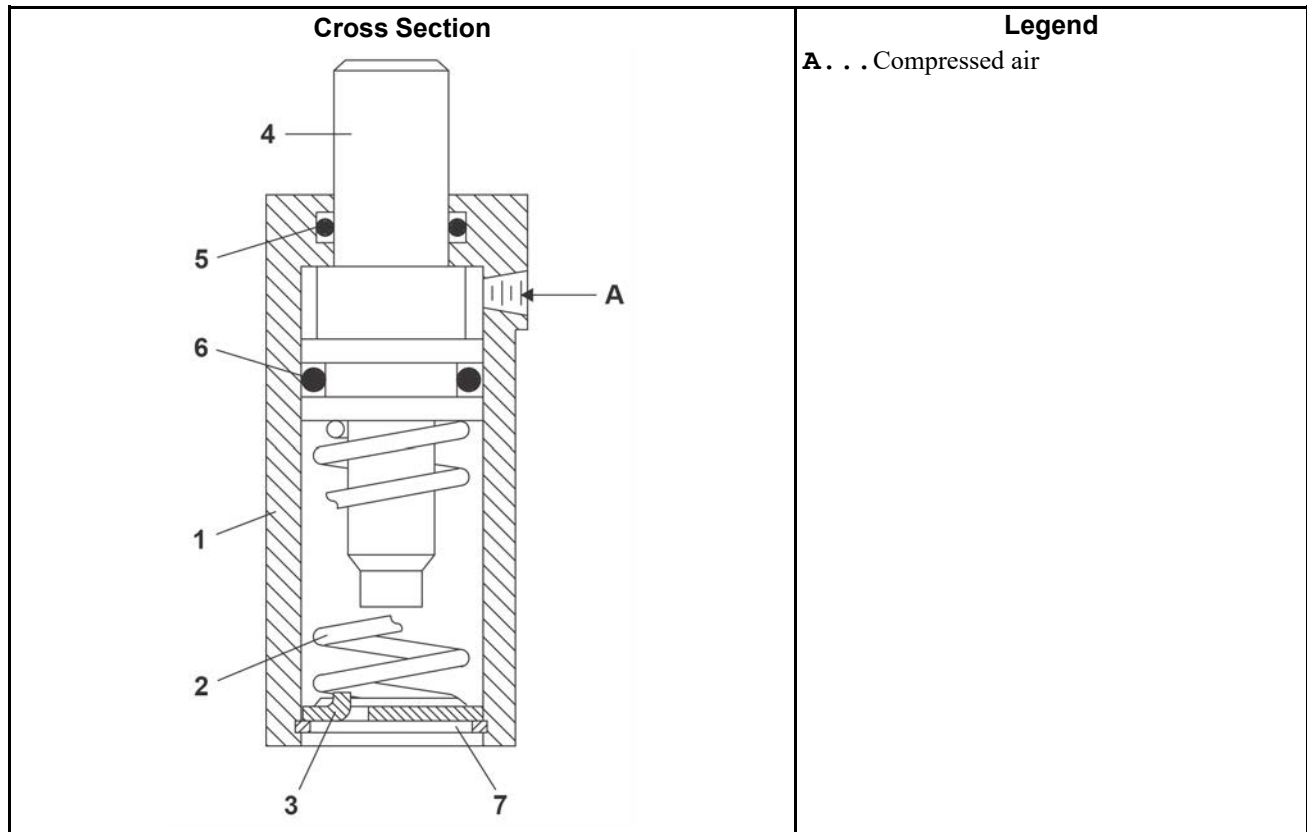

Table 25. Parts List—Door Latch

Find the assembly for your machine and the letter shown in the "Item" column. The components for your machine will show this letter or the word "all" in the "Used In" column. The numbers shown in the "Item" column are those shown in the illustrations.

Used In	Item	Part Number	Description/Nomenclature	Comments
Reference Assemblies				
	A	SA 10 020	* DOORLATCH ASSY-SMALL	
Components				
all	1	02 10188	CYLINDER=DOORLATCH OUR MATL	
all	2	02 10222	SPRING=DOOR LATCH=BALCOM	
all	3	02 10221	RETAINER=DOORLATCH SPRING	
all	4	Y2 10314	* PLUNGER=DOOR INTERLOCK	
all	5	60C112	ORING 5/8IDX3/32CS BUNA70 #114	
all	6	60C115	ORING 3/4IDX1/8CS BUNA70 #210	
all	7	17B014	INTRETRING IND#3000-X100-ST-ZD	

# 7 Chemical Supply

This page intentionally blank

# Soap Chute

2 Sheets

MWF100C7, MWF100Y7, MWF100J7, MWF100Z7; MWF125C7, MWF125Y7, MWF125J7, MWF125Z7

Figure 22. Soap Chute Components and Installation





**Soap Chute**

2 Sheets

MWF100C7, MWF100Y7, MWF100J7, MWF100Z7; MWF125C7, MWF125Y7, MWF125J7, MWF125Z7

**Table 26. Parts List—Soap Chute**

Find the assembly for your machine and the letter shown in the "Item" column. The components for your machine will show this letter or the word "all" in the "Used In" column. The numbers shown in the "Item" column are those shown in the illustrations.				
Used In	Item	Part Number	Description/Nomenclature	Comments
Components				
all	1	96TDC2AA71	1/2"N/C2WY240V50/60C VLV(DRYVC)	
all	2	98CX851324	HOSE CLAMP D13, CSM	
all	3	98CX873160	FLEXIBLE HOSE ID13XOD20X44M	
all	4	AWS30211A	PLASTIC SOAP ASSY	
all	5	98CX851341	HOSE CLAMP 2+1/4", CSM	
all	6	02 03870	FLEXTUBE=SOAPCHUTE 2"IDX24LG	

BPWM3C02 / 2022062

BPWM3C02.1 0000407389 A.3 C.3 1/31/22, 1:35 PM Released

### Peristaltic Chemical Inlets

2 Sheets

MWF100C7, MWF100Y7, MWF100J7, MWF100Z7; MWF125C7, MWF125Y7, MWF125J7, MWF125Z7



**Peristaltic Chemical Inlets**

2 Sheets

MWF100C7, MWF100Y7, MWF100J7, MWF100Z7; MWF125C7, MWF125Y7, MWF125J7, MWF125Z7

**Table 27. Parts List—Peristaltic Chemical Inlets**

Find the assembly for your machine and the letter shown in the "Item" column. The components for your machine will show this letter or the word "all" in the "Used In" column. The numbers shown in the "Item" column are those shown in the illustrations.				
Used In	Item	Part Number	Description/Nomenclature	Comments
Components				
all	1	96TDC2AA71	1/2"N/C2WY240V50/60C VLV	
all	2	98CX851324	HOSE CLAMP D13, CSM	
all	3	98CX873160	FLEXIBLE HOSE ID13XOD20X44M	
all	4	02 035890	MOLDED LIQ SUPPLY MANFOLD=10	
all	5	98CX851341	HOSE CLAMP 2+1/4", CSM	
all	6	98CX910816	FLEXIBLE HOSE ID25XOD34X44M	

# 8 Water and Drain

This page intentionally blank

**Water and Steam Schematic and Components**

2 Sheets

MWF100J7, MWF100Z7, MWF100C7, MWF100Y7; MWF125J7, MWF125Z7, MWF125C7, MWF125Y7

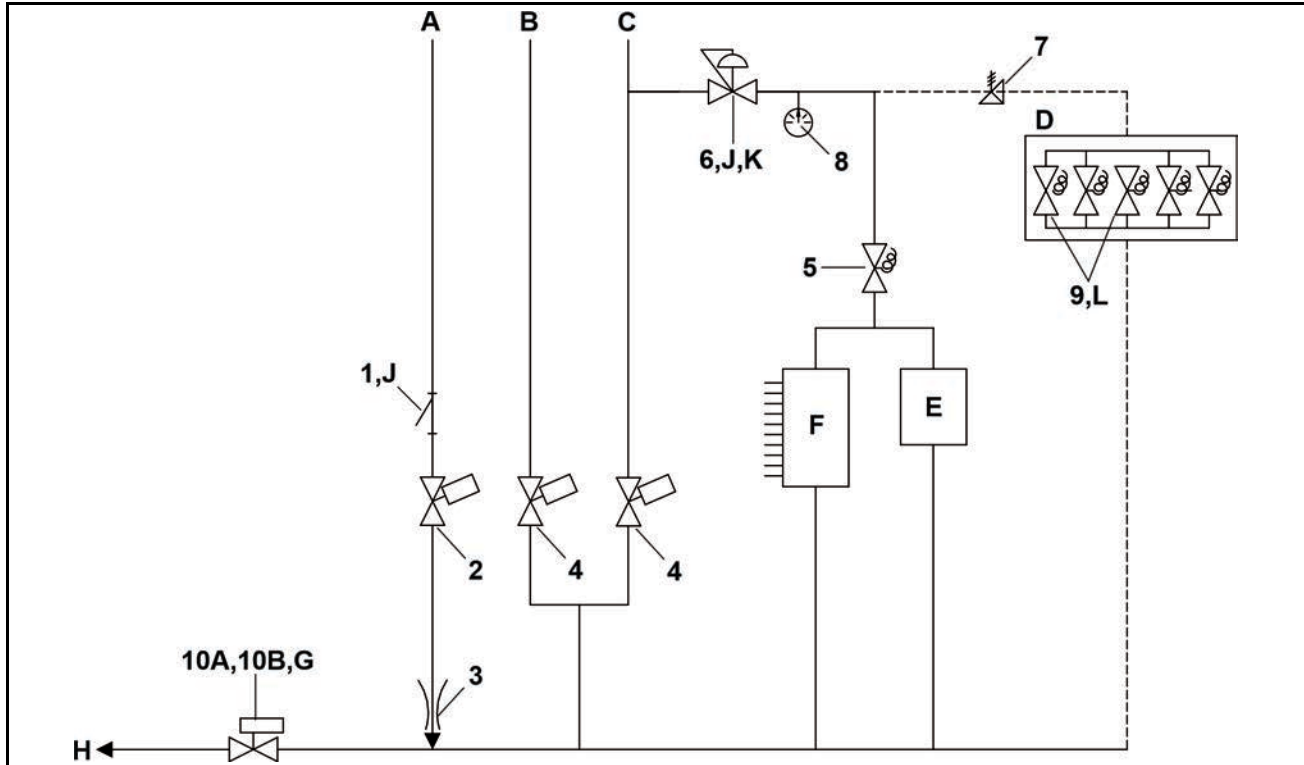

**Legend**

- A** . . . Steam inlet (optional)
- B** . . . Cold water inlet
- C** . . . Hot water inlet
- D** . . . Five compartments to flush in chemical supplies (optional)
- E** . . . Soap chute
- F** . . . 10 port/8 signal inlet for peristaltic liquid chemical systems
- G** . . . Drain valve body with one valve
- H** . . . Dirty water outlet to sewer
- J** . . . Keep this component clean. Refer to the related section in the Maintenance Guide.
- K** . . . Keep this component set to the correct pressure. Refer to the related section in the Maintenance Guide.
- L** . . . Five instances

**Water and Steam Schematic and Components**

2 Sheets

MWF100J7, MWF100Z7, MWF100C7, MWF100Y7; MWF125J7, MWF125Z7, MWF125C7, MWF125Y7

**Table 28. Parts List—Water and Steam Schematic and Components**

Find the assembly for your machine and the letter shown in the "Item" column. The components for your machine will show this letter or the word "all" in the "Used In" column. The numbers shown in the "Item" column are those shown in the illustrations.				
Used In	Item	Part Number	Description/Nomenclature	Comments
Reference Assemblies				
	A		REFERENCE	MWF100C7/Y7, MWF125C7/Y7
	B		REFERENCE	MWF100J7/Z7, MWF125C7/Y7
Components				
all	1	98CX820631	STEAM STRAINER 1+1/4", CSM	
all	2	96D0011E	1.25"NPTBRZ N/C STEAMVALANGBD	
all	3	X6 20247A	3/4" NPT .5" SPARGER MACH.	
all	4	96D087WE	ANGBODVLV 1.5"N/C H2O BURK BRZ	
all	5	96TDC2AA71	1/2"N/C2WY240V50/60C VLV(DRYVC)	
all	6	98CX820820	PRESSURE REGULATOR, 3/4 28PSI	
all	7	96M001	1/2X3/8" RELIEF VALVE SET31#	
all	8	98CX902450	PRESSGAUGE R1/4",0-28PSI	
all	9	96TCC2AA71	3/8" N/C 2WAY 240V50/60C VALVE	
A	10A	98CF06500B	DUMP VALVE ASSY, 4840F CSM	DRAIN DOWN
B	10B	98MW3604	PNEUMATIC DRAIN VALVE WMF	DRAIN TO REAR

## Water Inlet Components and Installation

2 Sheets

MWF100J7, MWF100Z7, MWF100C7, MWF100Y7; MWF125J7, MWF125Z7, MWF125C7, MWF125Y7

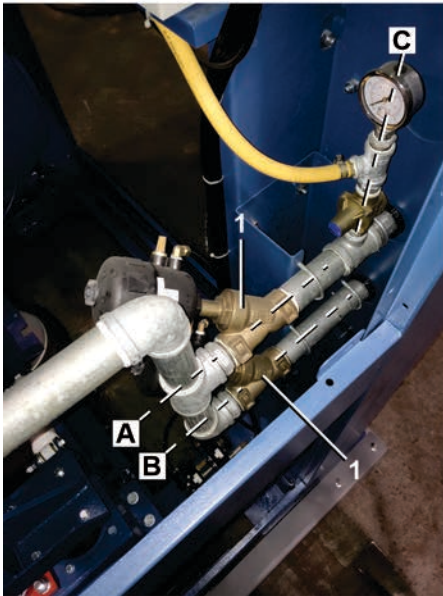
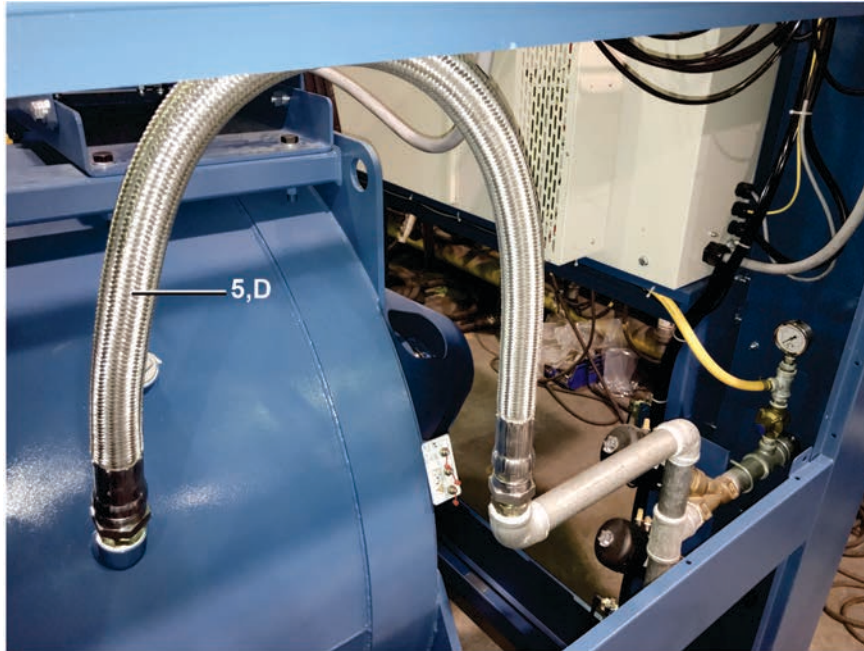

### Legend

- A . . . Hot water line
- B . . . Cold water line
- C . . . Hot water line for the chemical supply
- D . . . Hose is braided for tilt models and corrugated for non-tilt models, see parts list.



# Water Inlet Components and Installation

2 Sheets

MWF100J7, MWF100Z7, MWF100C7, MWF100Y7; MWF125J7, MWF125Z7, MWF125C7, MWF125Y7

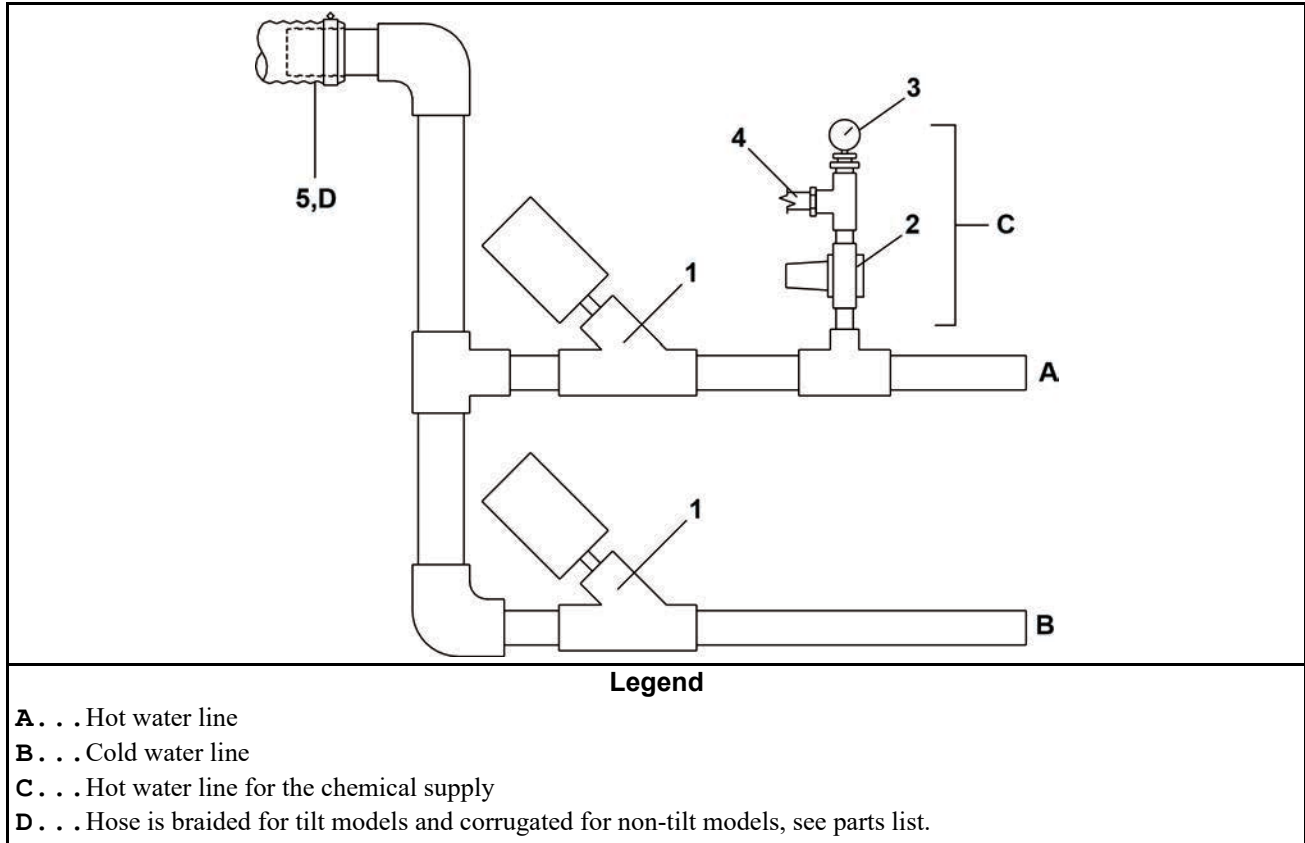

**Table 29. Parts List—Water Inlet Components and Installation**

Find the assembly for your machine and the letter shown in the "Item" column. The components for your machine will show this letter or the word "all" in the "Used In" column. The numbers shown in the "Item" column are those shown in the illustrations.				
Used In	Item	Part Number	Description/Nomenclature	Comments
Reference Assemblies				
	A		REFERENCE	MWF100J7, MWF100Z7, MWF125J7, MWF125Z7
	B		REFERENCE	MWF100C7, MWF100Y7, MWF125C7, MWF125Y7
Components				
all	1	96D087WE	ANGBODVLV 1.5"N/C H2O BURK BRZ	
all	2	98CX820820	PRESSURE REGULATOR, 3/4 28PSI	
all	3	98CX902450	PRESSGAUGE R1/4",0-28PSI	
all	4	98CX873160	FLEXIBLE HOSE ID13XOD20X44M	
A	5	98CF873138	FILL HOSE 2", 4840F CSM	
B	5	98CF489218	WATER HOSE 2" BRAIDED, 4840F TILT CSM	

BPWM4W01 / 2022082A

BPWM4W01.1 0000407313 B.3 C.3 2/14/22, 1:32 PM Released

**Steam**

2 Sheet

MWF100C7/Y7, MWF100 J7/Z7, MWF125C7/Y7, MWF125J/Z7

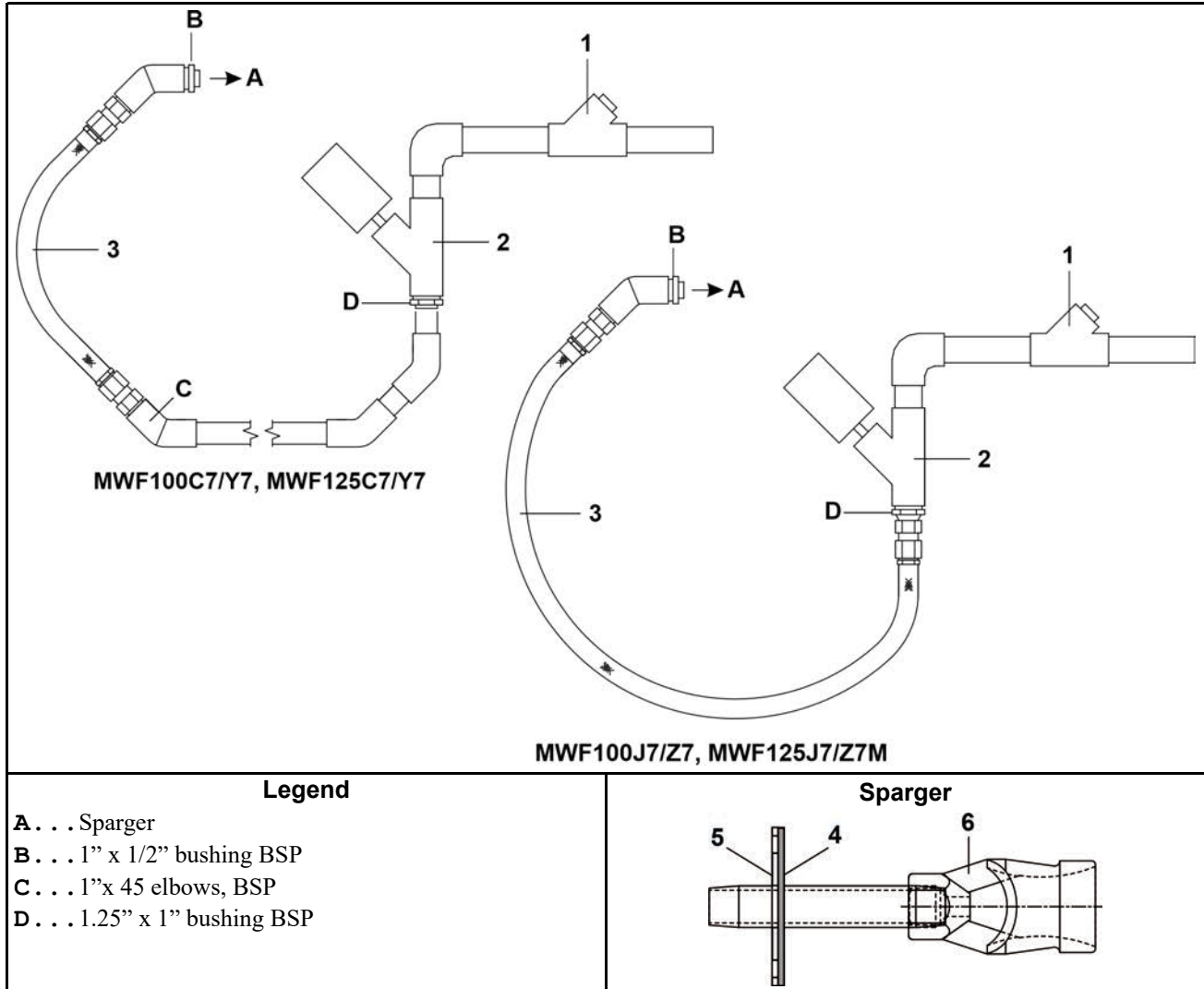

**Table 30. Parts List—Steam**

Find the assembly for your machine and the letter shown in the "Item" column. The components for your machine will show this letter or the word "all" in the "Used In" column. The numbers shown in the "Item" column are those shown in the illustrations.				
Used In	Item	Part Number	Description/Nomenclature	Comments
Reference Assemblies				
	A		REFERENCE	MWF100C7,Y7
	B		REFERENCE	MWF100J7,Z7
	C		REFERENCE	MWF125C7,Y7
	D		REFERENCE	MWF125J7,Z7
Components				
all	1	98CX820631	STEAM STRAINER 1+1/4", CSM	

**Steam**

2 Sheet

MWF100C7/Y7, MWF100 J7/Z7, MWF125C7/Y7, MWF125J/Z7

**Table 30 Parts List—Steam (cont'd.)**

Find the assembly for your machine and the letter shown in the "Item" column. The components for your machine will show this letter or the word "all" in the "Used In" column. The numbers shown in the "Item" column are those shown in the illustrations.				
Used In	Item	Part Number	Description/Nomenclature	Comments
all	2	96D0011E	1.25"NPTBRZ N/C STEAMVALANGBD	
all	3	98MW800419	STEAM HOSE BRAIDED,MWF100	
all	4	02 11369D	GASKET STEAM FLANGE MTG DYE	
all	5	W2 11365	*STEAM PIPE+FLANGE WLMT	
all	6	X6 20247A	3/4" NPT .5" SPARGER MACH.	

**Drain Valve to Rear**

MWF100J7,MWF100Z7; MWF125J7, MWF125Z7

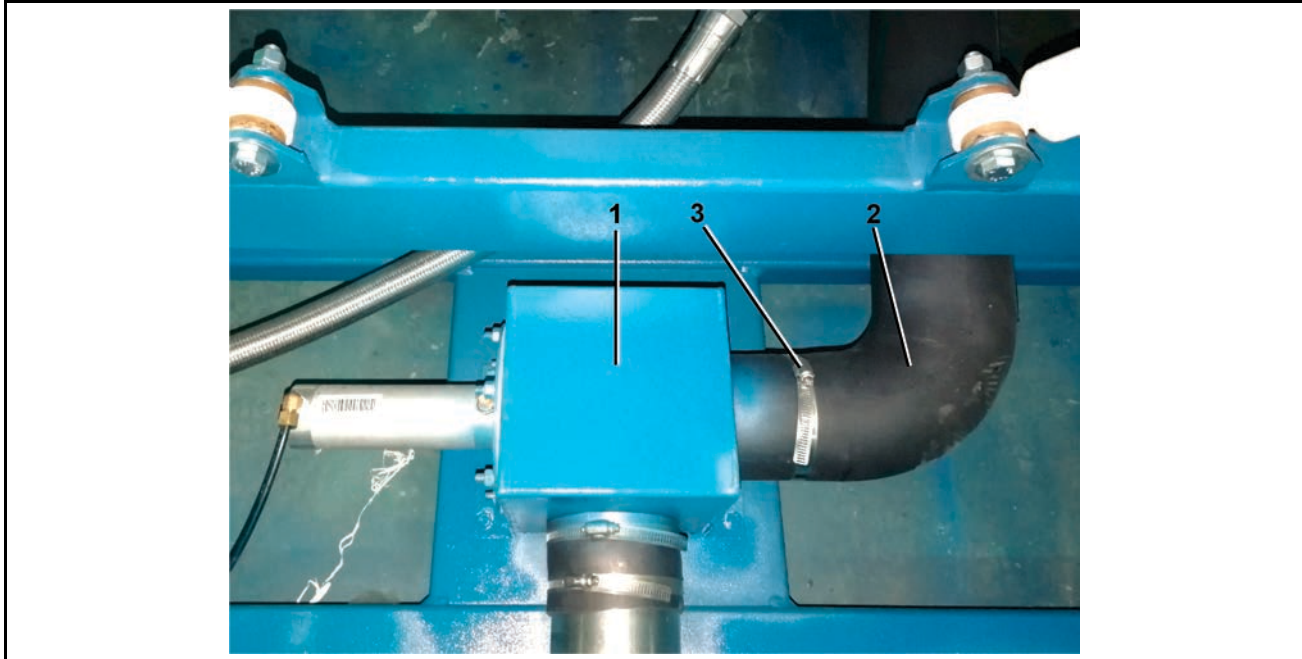

**Table 31. Parts List—Drain Valve to Rear**

Find the assembly for your machine and the letter shown in the "Item" column. The components for your machine will show this letter or the word "all" in the "Used In" column. The numbers shown in the "Item" column are those shown in the illustrations.				
Used In	Item	Part Number	Description/Nomenclature	Comments
Components				
all	1	98MW4805	PNEUMATIC DRAIN VALVE,MWF100	
all	2	98MW90615	DRAIN HOSE,MWF100	
all	3	27A088S	HOSECLAMP 3+1/16-4"SSSCR#HSS56	

This page intentionally blank

BPWMFW01 / 2022063

BPWMFW01.1 0000407395 B.2 C.3 2/1/22, 11:53 AM Released

### Drain Valve to Bottom

2 Sheets

MWF63C/Y, MWF77C/Y, MWF100C/Y, MWF125C/7- Standard; MWF63J/Z, MWF77J/Z, MWF100J/Z, MWF125J/Z - Optional

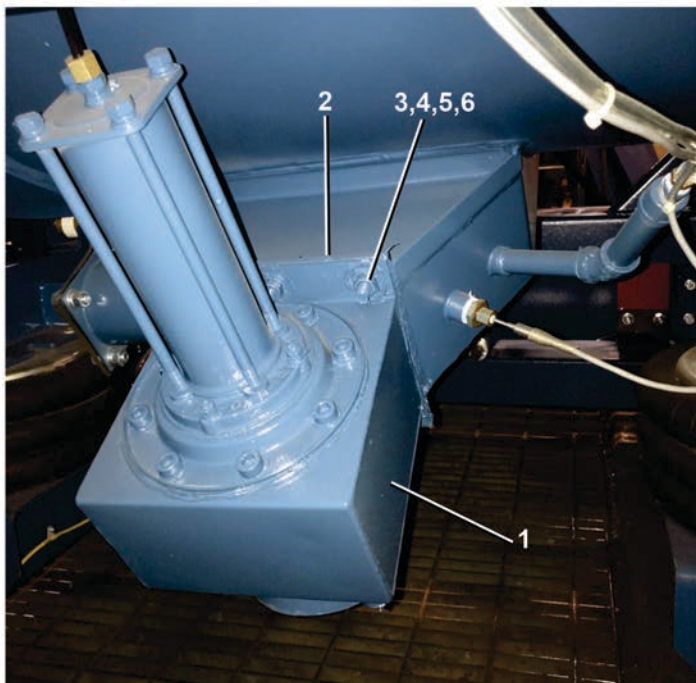
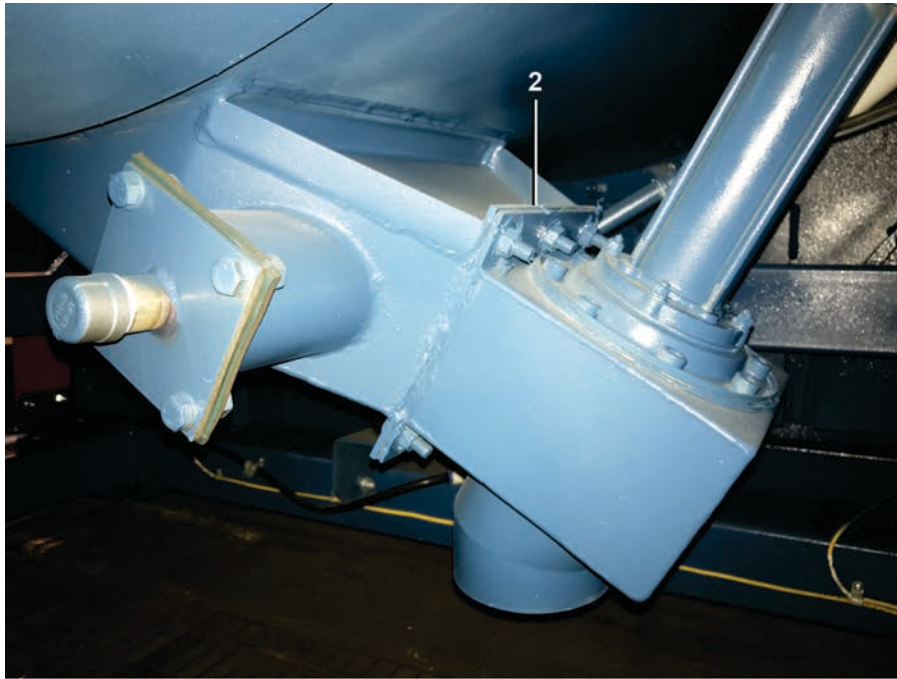

**Drain Valve to Bottom**

2 Sheets

MWF63C/Y, MWF77C/Y, MWF100C/Y, MWF125C/7- Standard; MWF63J/Z, MWF77J/Z, MWF100J/Z,  
MWF125J/Z - Optional

**Table 32. Parts List—Drain Valve to Bottom**

Find the assembly for your machine and the letter shown in the "Item" column. The components for your machine will show this letter or the word "all" in the "Used In" column. The numbers shown in the "Item" column are those shown in the illustrations.				
Used In	Item	Part Number	Description/Nomenclature	Comments
Components				
all	1	A14 06500	*DUMP VALVE ASSY=4"NPT SS	
all	2	02 15026	GASKET-7"SQ=4"FLGDUMP VALVE	
all	3	15K100MS	HEXSCR M10X30 FULLTHREAD SS	
all	4	15U275MS	LOCKWASH D10 SS	
all	5	24G030N	ROLLED WASH.379ID NYLTITE 37W	
all	6	15G206MS	HEXNUT, M10 SS	

# 9 Pneumatic Assemblies



BPWMEP01 / 2022075

BPWMEP01.1 0000407542 A.5 C.3 2/10/22, 11:52 AM Released

# Pneumatic Schematic

3 Sheets

MWF100J7, MWF100Z7

Figure 23. Schematic Key

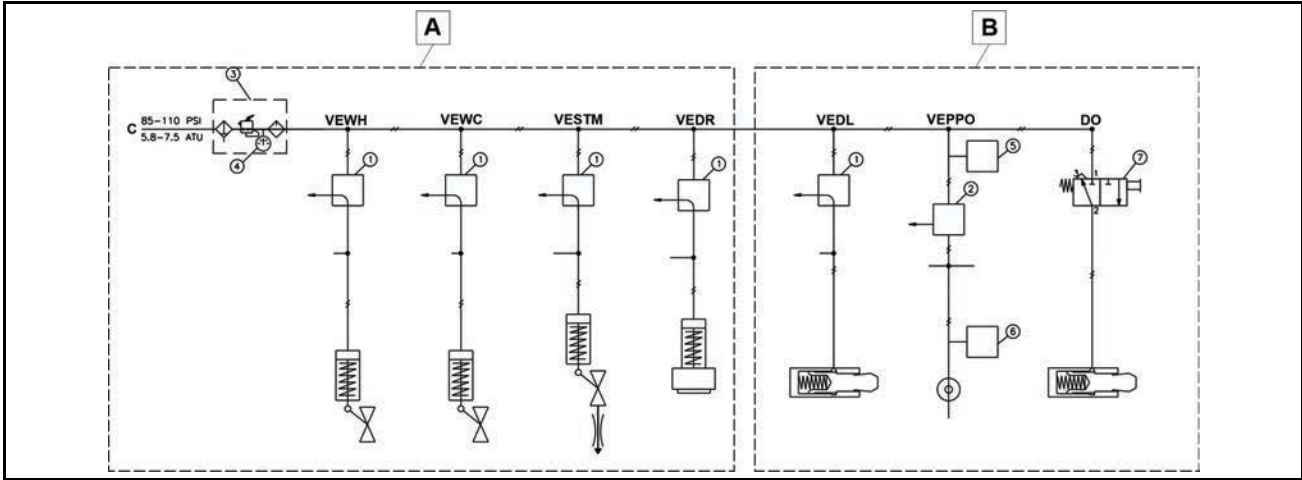

**NOTE:** All pilot valves shown de-energized

Figure 24. Enlarged View A

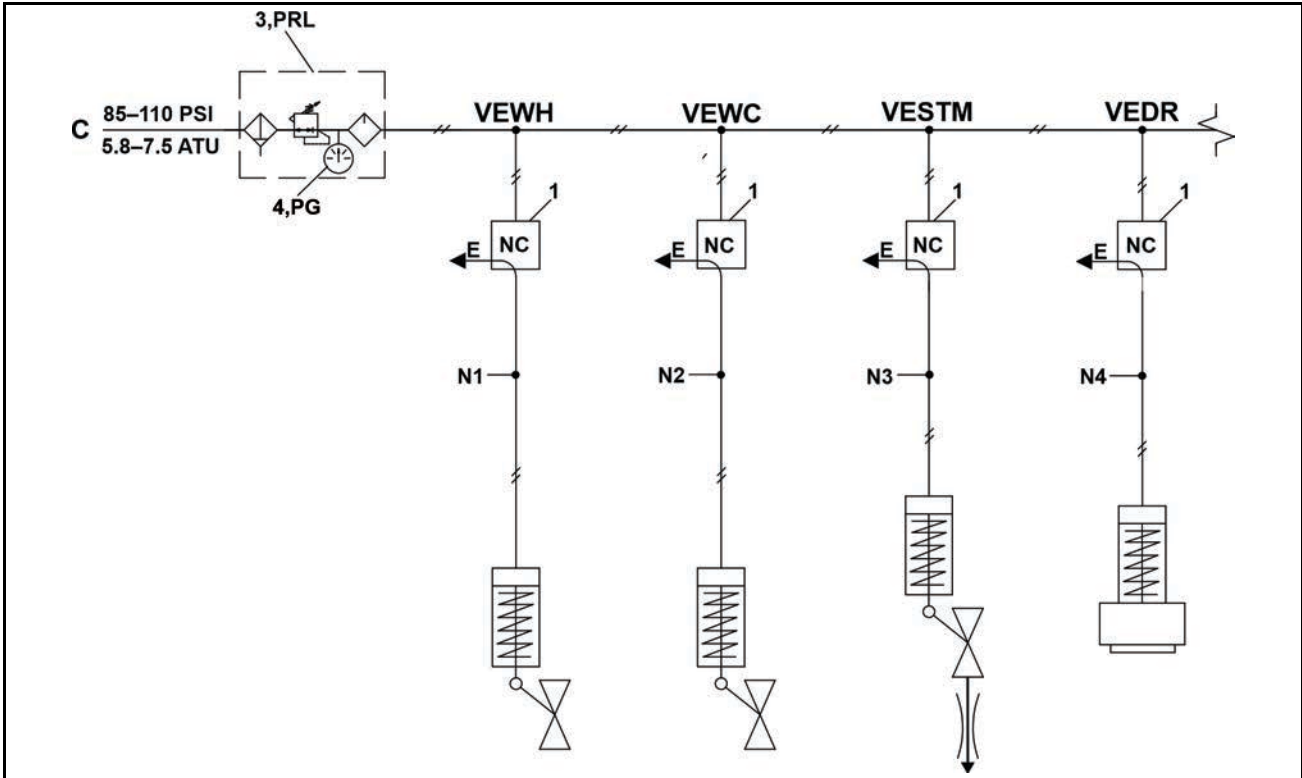

Figure 26: Pneumatic Schematic Descriptions and Notes, page 100

# Pneumatic Schematic

MWF100J7, MWF100Z7

3 Sheets

Figure 25. Enlarged View B

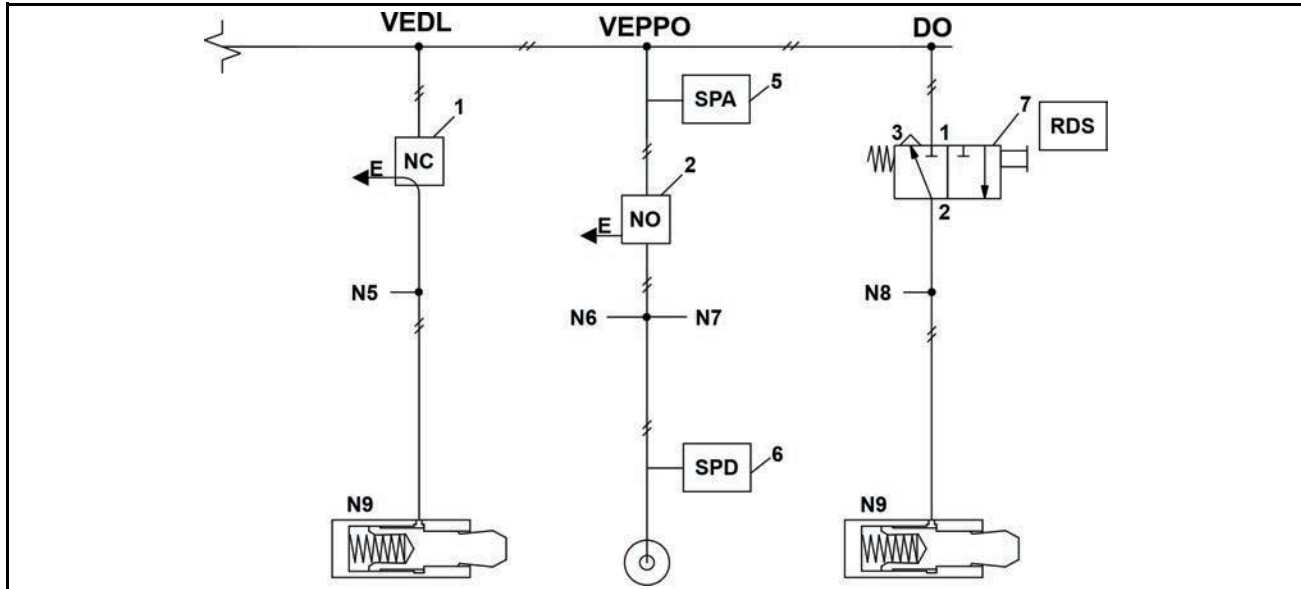

Figure 26: Pneumatic Schematic Descriptions and Notes, page 100

Figure 26. Pneumatic Schematic Descriptions and Notes

Legend	Legend
<b>C</b> . . . Air	<b>N8</b> . . Press door release switch to send air to retract plunger and release door open lock
<b>DO</b> . . Door open latch	<b>N9</b> . . Spring lock air open
<b>E</b> . . . Exhaust	<b>NC</b> . . Normally closed
<b>N1</b> . . Pressure is applied to actuator to open hot water valve when pilot valve is energized	<b>NO</b> . . Normally open
<b>N2</b> . . Pressure is applied to actuator to open cold water valve when pilot valve is energized	<b>PG</b> . . Pressure gage maxium 150PSI
<b>N3</b> . . Pressure is applied to actuator to open steam valve when pilot valve is energized	<b>PRL</b> . . Pressure regulator lubricator
<b>N4</b> . . Pressure is applied to actuator to open drain valve when pilot valve is energized	<b>RDS</b> . . Release door switch, push button 3-way valve normally exhausting
<b>N5</b> . . Pressure is applied to latch to retract and open latch when pilot valve is energized	<b>SPA</b> . . Air available pressure switch
<b>N6</b> . . Pressure is applied to seals to inflate seals when pilot is de-energized	<b>SPD</b> . . Door seal pressure switch
<b>N7</b> . . When pilot is energized, pressure exhausts from the seals to deflate. When air pressure is less than 9lbs, the door latch pilot is energized.	<b>VEDL</b> . . Door latch
	<b>VEDR</b> . . Drain
	<b>VEPP0</b> . . Door seals
	<b>VESTM</b> . . Steam
	<b>VEWC</b> . . Cold
	<b>VEWH</b> . . Hot

**Pneumatic Schematic**

3 Sheets

MWF100J7, MWF100Z7

**Table 33. Parts List—Pneumatic Schematic**

Find the assembly for your machine and the letter shown in the "Item" column. The components for your machine will show this letter or the word "all" in the "Used In" column. The numbers shown in the "Item" column are those shown in the illustrations.				
Used In	Item	Part Number	Description/Nomenclature	Comments
Components				
all	1	96R301B71	1/8" AIRPILOT 3W NC 240V50/60	
all	2	96R302B71	1/8" AIRPILOT 3W NO 240V50/60	
all	3	98CX880511	CSM AIR REGULATOR G1/4 W/O GAGE	
all	4	98CX880511B	PRESS GAGE 0-150PSI, 1/8BSP,CSM	
all	5	09N082A	PRESSW NASON CLOSE @ 62 LB.	
all	6	09N082B10	PRESSW NASON CLOSE FALLING AT 9PSI	
all	7	96N005	3WAY AIROP CONT.VLV.CLIPP#MJV3	

# 10 Control and Sensing

BPWMBZ01 / 2022062

BPWMBZ01.1 0000407434 A.3 C.3 1/31/22, 1:43 PM Released

# Water Level & Temperature Sensor

1 Sheet

MWF45J8/Z8, MWF63J7/Z7, MWF77J7/Z7, MWF100J7/Z7, MWF125J7/Z7; MWF45C8/Y8, MWF63C7/Y7, MWF77C7/Y7, MWF100C7/Y7, MWF125C7/Y7

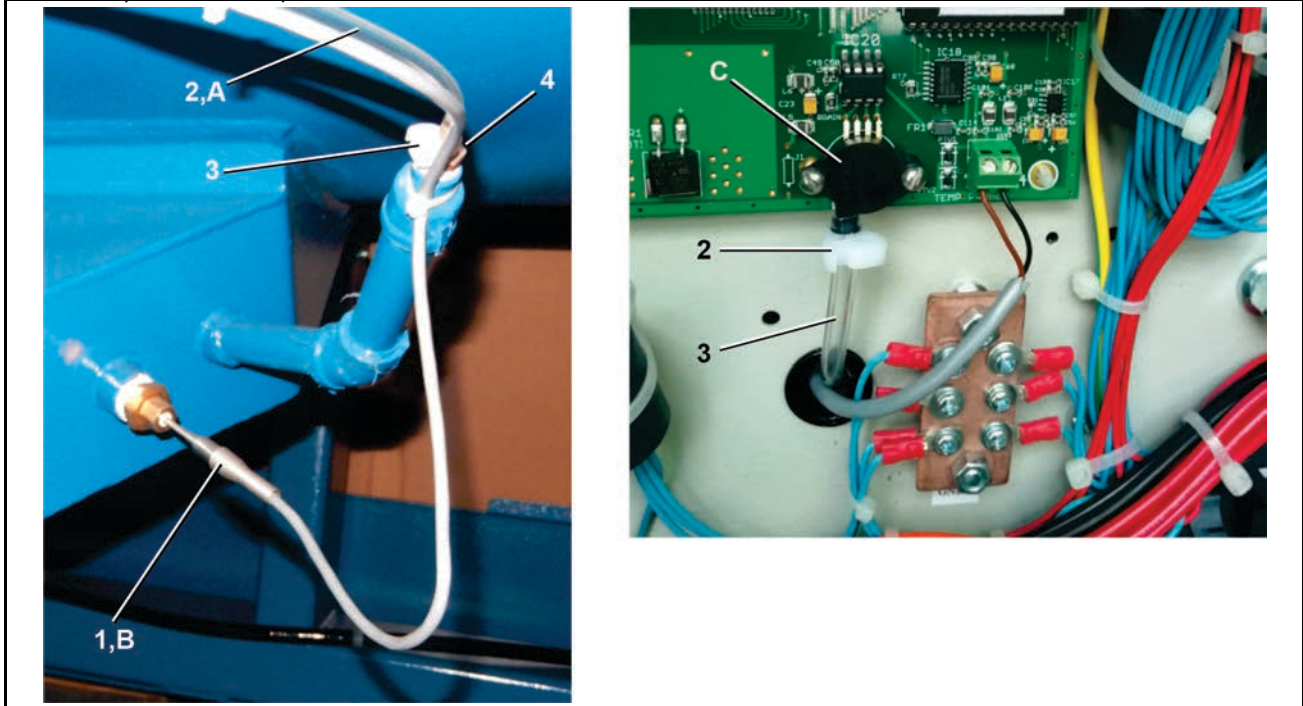

### Legend

- A . . . To transducer
- B . . . Temperature probe
- C . . . Transducer

**Table 34. Parts List—Water Level & Temperature Sensor**

Find the assembly for your machine and the letter shown in the "Item" column. The components for your machine will show this letter or the word "all" in the "Used In" column. The numbers shown in the "Item" column are those shown in the illustrations.				
Used In	Item	Part Number	Description/Nomenclature	Comments
Reference Assemblies				
	A		REFERENCE	E-P Plus® MODELS, MWF45J8/C8, MWF63J7/C7, MWF77J7/C7, MWF100J7/C7, MWF125J7/C7
	B		REFERENCE	MilTouch™ MODELS, MWF45Z8/Y8, MWF63Z7/Y7, MWF77Z7/Y7, MWF100Z7/Y7, MWF125Z7/Y7
Components				
all	1	30R0043PB	TEMPERATURE PROBE ASSY=BRASS	
A	2	60E004NT	TUBING (NYL.)CLR.1/4"ODX1/8"	
B	2	60E004NA	TUBING CLEAR PVC 3/16"IDX5/16"OD	
A	3	27A047	HOSECLMP 1/8HOSEID CLIP#5000-2	
B	3	27A047A	HOSE CLAMP 5/16" NOMINIAL MIN .256", MFG#5700149	

**Water Level & Temperature Sensor**

1 Sheet

MWF45J8/Z8, MWF63J7/Z7, MWF77J7/Z7, MWF100J7/Z7, MWF125J7/Z7; MWF45C8/Y8, MWF63C7/Y7,  
MWF77C7/Y7, MWF100C7/Y7, MWF125C7/Y7

**Table 34 Parts List—Water Level & Temperature Sensor (cont'd.)**

Find the assembly for your machine and the letter shown in the "Item" column. The components for your machine will show this letter or the word "all" in the "Used In" column. The numbers shown in the "Item" column are those shown in the illustrations.				
Used In	Item	Part Number	Description/Nomenclature	Comments
A	4	98CX932420	HOSESTEM BRASS 1/4"BSP X 1/8"HOSE ID	
B	4	98CX932420A	HOSESTEM BRASS 1/4"BSP X 3/16"HOSE ID	

# 11 Dimensional Drawings

This page intentionally blank



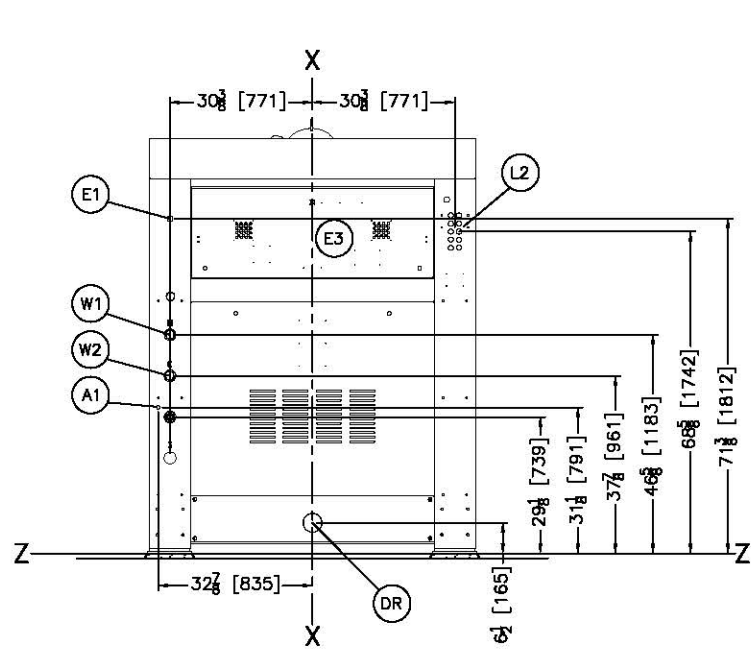
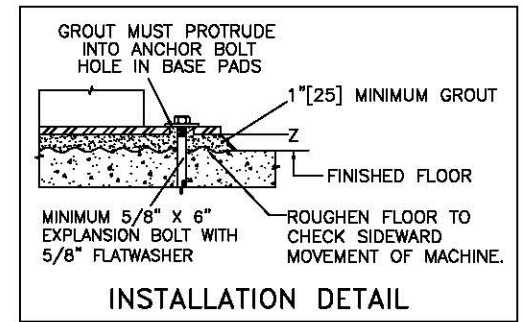

REAR VIEW

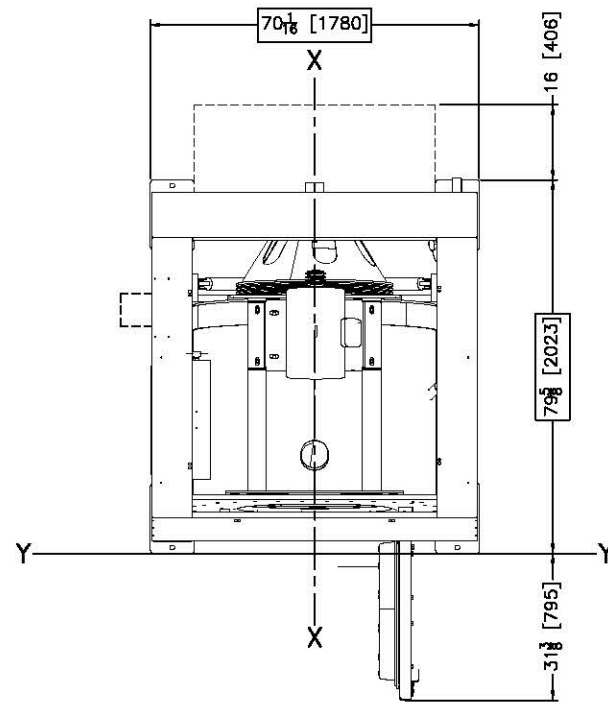

PLAN VIEW

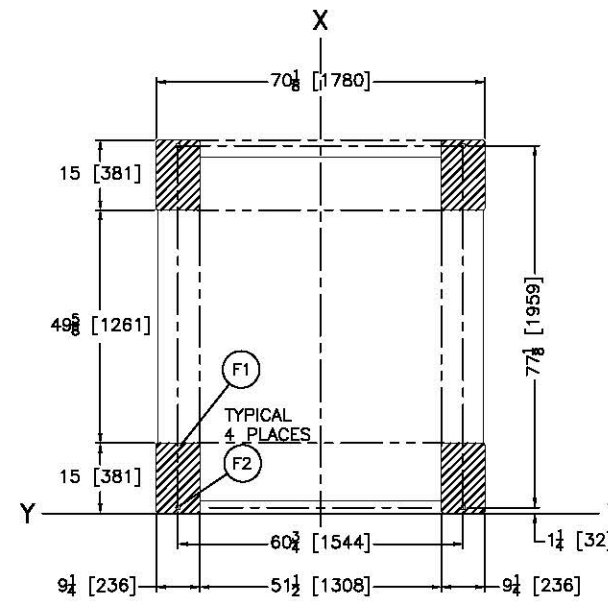

FOUNDATION PLAN

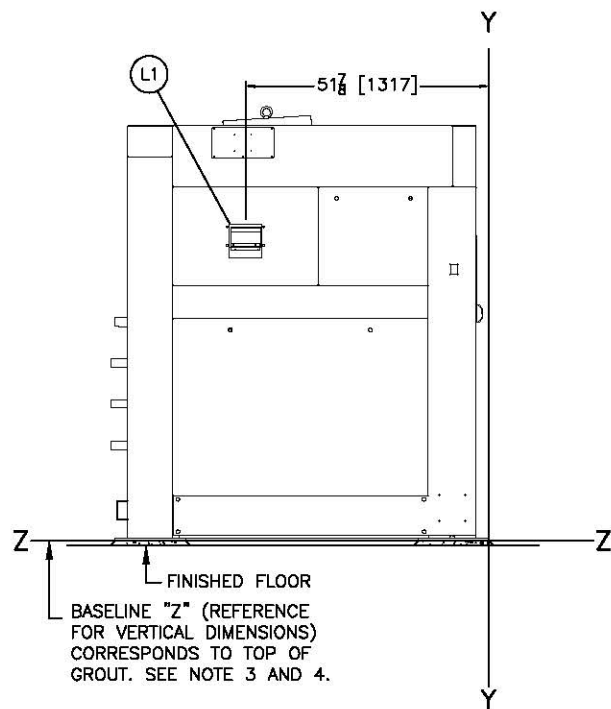

LEFT VIEW

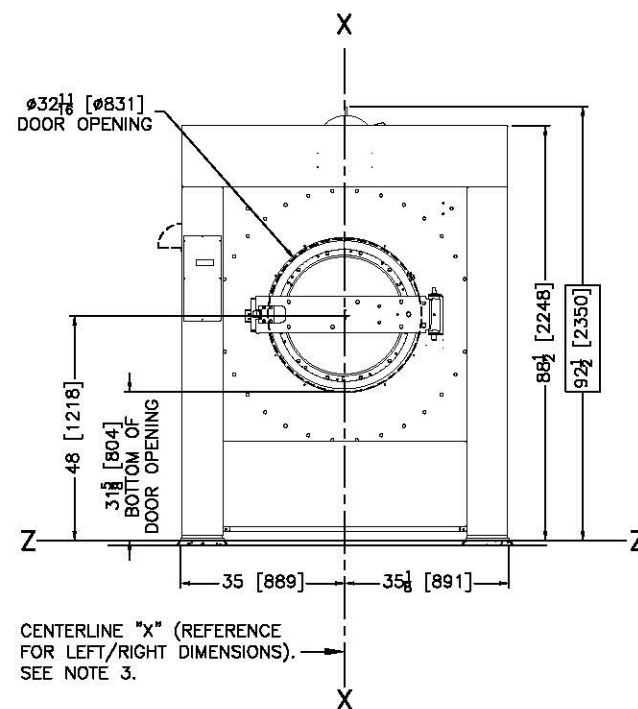

FRONT VIEW

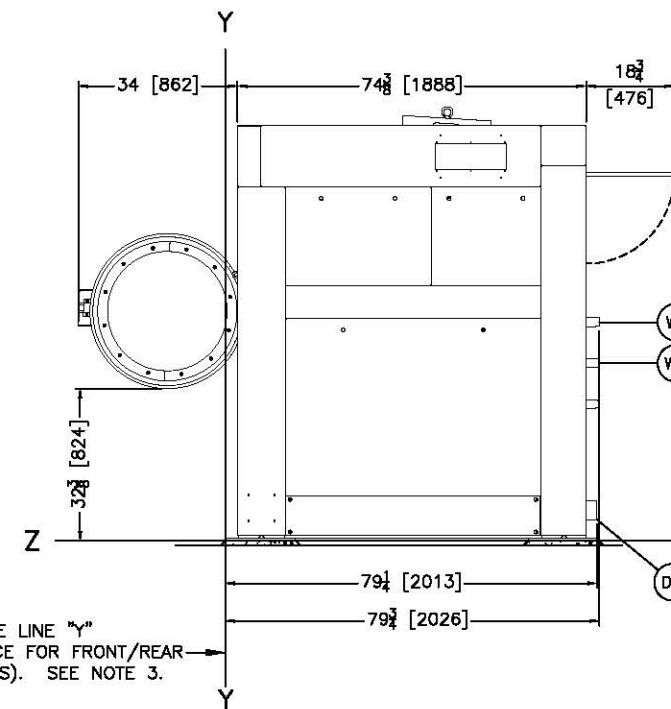

RIGHT VIEW

ITEM	LEGEND
W2	COLD WATER INLET, 1-1/2" NPT CONNECTION, AIR-OPERATED.
W1	HOT WATER INLET, 1-1/2" NPT CONNECTION, AIR-OPERATED.
L2	FLUSHING LIQUID CHEMICAL PORTS, SEE NOTE 10.
L1	STANDARD SOAP CHUTE
F4	DRAIN HOLES
F3	GROUT HOLES
F2	(4) 1-1/16" DIAMETER ANCHOR BOLT HOLES, USE 5/8" X 6" BOLTS MINIMUM.
F1	BASEPADS, 6 PLACES, SEE NOTE 8.
E3	MICROPROCESSOR CONTROL BOX
E2	E-P Plus® Controller - MWF77J7 MODELS, MiiTouch™ Controller - MWF77Z7 MODELS
E1	MAIN ELECTRICAL CONNECTION
DR	DRAIN TO REAR, AIR OPERATED, 4"(102) DIAMETER PIPE SOCKET JOINT
A1	MAIN AIR, 1/4" NPT CONNECTION, CUSTOMER MUST SUPPLY AIR STRAINER

- NOTES**
- 11 12" [305] MINIMUM CLEARANCE IS RECOMMENDED FOR SERVICE TO MACHINE ON SIDES NOT REQUIRING OPERATOR ACCESS. 16" [406] MINIMUM IS RECOMMENDED FOR OPERATOR ACCESS TO SOAP SUPPLY. SEE LOCAL ELECTRIC CODES FOR REQUIRED CLEARANCES.
  - 10 SIX (6) PORTS WITH FIVE (5) CHEMICAL SIGNALS ON MWF100J7. SIX (6) PORTS WITH EIGHT (8) CHEMICAL SIGNALS ON MWF100Z7.
  - 9 SHIM TO LEVEL THE MACHINE AND ALLOW FOR 1" [25] MINIMUM GROUT. ANCHOR ALL LABELED ANCHOR BOLT HOLES. USE 5/8" X 6" BOLTS, MINIMUM. SEE INSTALLATION MAINTENANCE MANUAL FOR FURTHER INSTRUCTIONS.
  - 8 SHADED AREA DENOTES BASE PADS WHICH MUST BE CONTINUOUSLY SUPPORT.
  - 7 DO NOT PRE-PIPE ANY CLOSER THAN 60 [1524].
  - 6 AS OF THIS WRITING, THE MINIMUM CLEARANCE REQUIRED BY U.S. NATIONAL ELECTRIC CODES, FROM ELECTRIC BOX TO ANY OBJECT IS:  
36 [914] IF OBJECT IS AN UNGROUNDED (INSULATED) WALL.  
42 [1067] IF OBJECT IS A GROUNDED WALL (e.g. BARE CONCRETE, BRICK, ETC.)  
48 [1219] IF OBJECT IS ANY LIVE PART.  
CHECK LOCAL ELECTRIC CODES FOR FURTHER RESTRICTIONS.
  - 5 CUSTOMER TO SUPPLY CIRCUIT BREAKER OR FUSED BRANCH CIRCUIT DISCONNECT (SAFETY) SWITCHES WITH LAG TYPE FUSES FROM POWER SOURCE TO MACHINE. A SEPARATE GROUND WIRE MUST BE CONNECTED FROM DISCONNECT TO EQUIPMENT.
  - 4 BASELINE "Z" IS THE SAME FOR ALL MILNOR MACHINES AND IS SHOWN ON ALL DIMENSIONAL DRAWINGS. THE DISTANCE BETWEEN BASELINE "Z" AND THE FINISHED FLOOR MAY VARY (WITH CHANGES IN FLOOR HEIGHT) AS REQUIRED TO INSURE THAT BASELINE "Z" IS HORIZONTAL AND ALL COMPONENTS REQUIRING GROUT ARE SET ON A MINIMUM 1" [25] THICK GROUT BED.
  - 3 USE REFERENCE LINES "X", "Y", AND "Z" TO LOCATE ALL SERVICE CONNECTIONS.
  - 2 NUMBERS IN BRACKETS [ ] DENOTE DIMENSIONS IN MILLIMETERS.
  - 1 ALL DIMENSIONS SHOWN ARE APPROXIMATE, SUBJECT TO NORMAL MANUFACTURING TOLERANCES, AND TO OCCASIONAL CHANGES WITHOUT NOTICE THROUGH REDESIGN AND/OR RELOCATION OF COMPONENTS, ETC. DO NOT USE FOR CONSTRUCTION UNLESS CERTIFIED, AND IN NO EVENT PRE-PIPE CLOSER THAN FIVE FEET FROM MACHINE. FACTORY MUST BE CONSULTED FOR DIMENSIONS IF MACHINE IS TO BE MOVED THROUGH NARROW OR LOW CORRIDORS OR OPENINGS.

**ATTENTION**  
MOST REGULATORY AUTHORITIES (INCLUDING OSHA IN THE USA) HOLD THE OWNER/USER ULTIMATELY RESPONSIBLE TO MAINTAIN A SAFE WORKING ENVIRONMENT. ACCORDINGLY, THE OWNER/USER MUST RECOGNIZE ALL FORESEEABLE SAFETY HAZARDS, FURNISH SAFETY INSTRUCTIONS AND GUIDANCE TO ALL PERSONNEL WHO MAY COME IN CONTACT WITH THE INSTALLATION, AND PROVIDE ALL NECESSARY ADDITIONAL SAFETY GUARDS, FENCES, RESTRAINTS, DEVICES, ETC., NOT FURNISHED BY THE EQUIPMENT MANUFACTURER OR VENDOR.

**ATTENTION**  
THE FLOOR AND/OR OTHER SUPPORT COMPONENTS MUST HAVE SUFFICIENT STRENGTH (AND RIGIDITY WITH DUE CONSIDERATION FOR NATURAL OR RESONANT FREQUENCY THEREOF) TO WITHSTAND THE FULLY LOADED WEIGHT OF THE MACHINE INCLUDING THE GOODS, THE WATER, AND ANY REPEATED SINUSOIDAL (ROTATING) FORCES GENERATED DURING ITS OPERATION. WRITE THE FACTORY FOR ADDITIONAL MACHINE DATA FOR USE BY A COMPETENT SOIL AND/OR STRUCTURAL ENGINEER.

MWF100J7, MWF100Z7

BDMWF100JZAE  
2022276D

**MILNOR** PELLERIN MILNOR CORPORATION  
P.O. Box 400 Kenner, LA 70063, USA, Phone 504/467-8581,  
FAX 504/468-3084, Email: milnoinfo@milnor.com

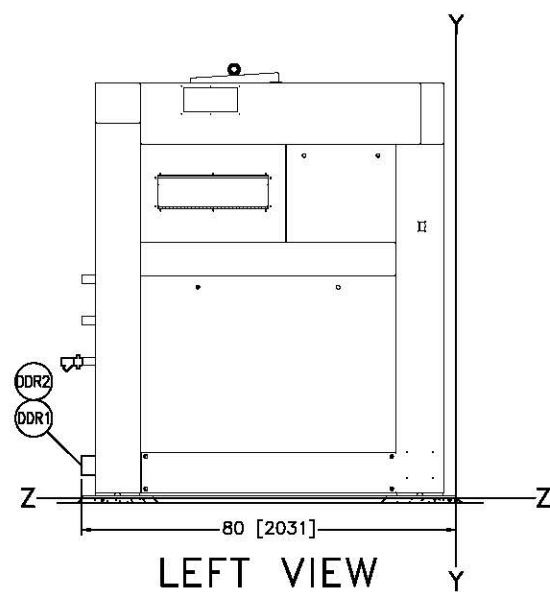

LEFT VIEW

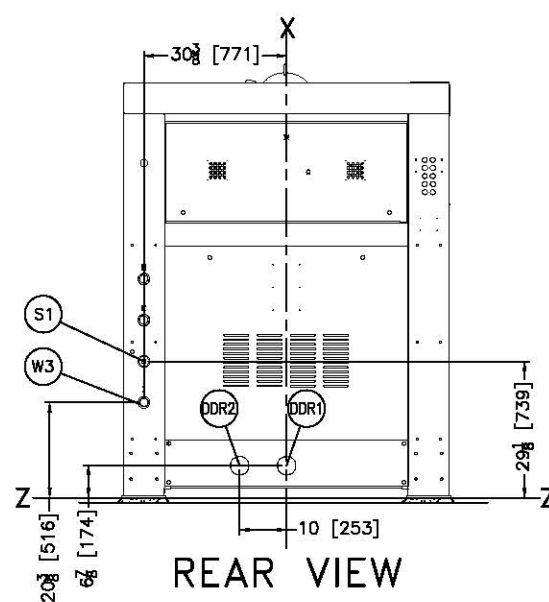

REAR VIEW

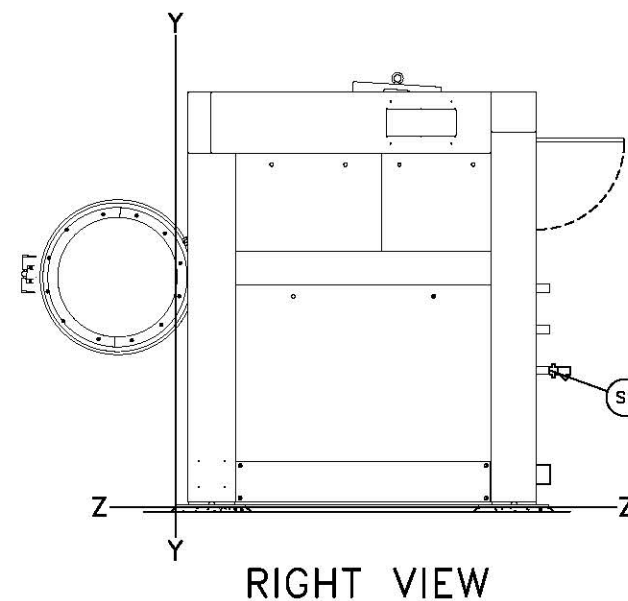

RIGHT VIEW

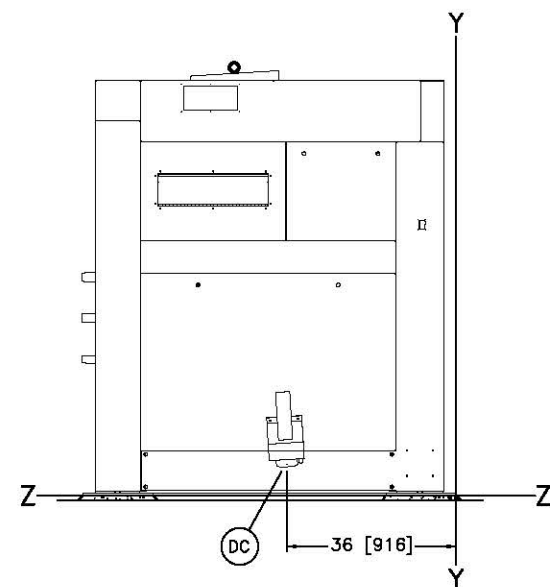

LEFT VIEW

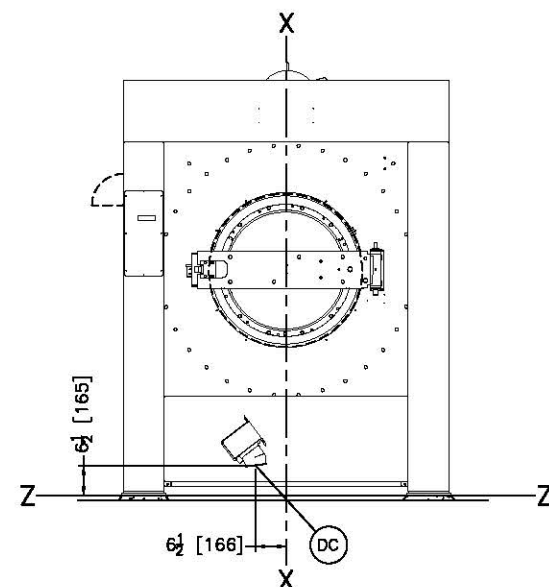

FRONT VIEW

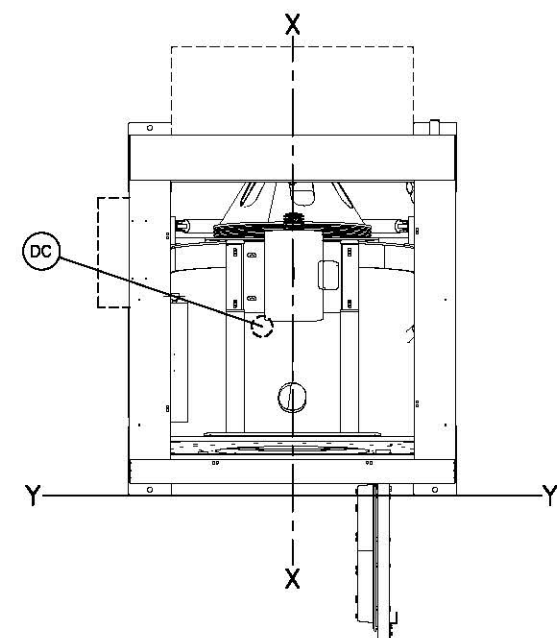

PLAN VIEW

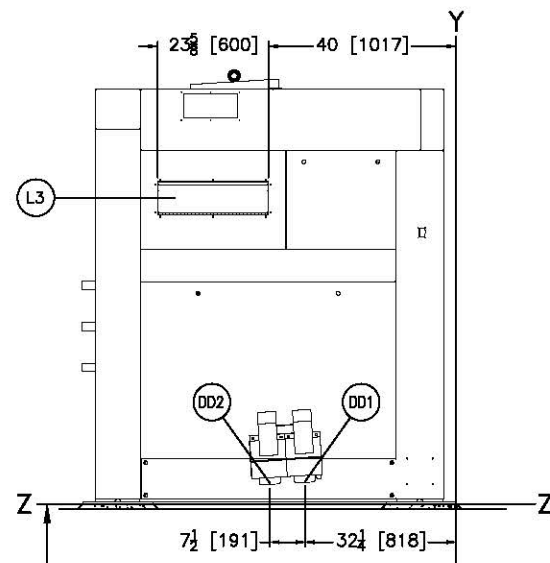

LEFT VIEW

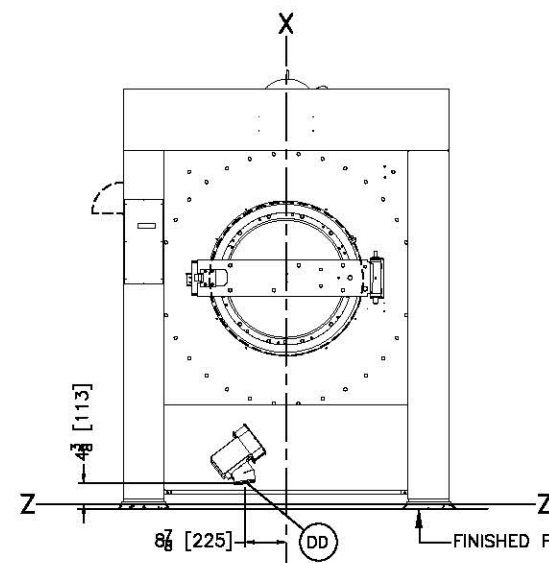

FRONT VIEW

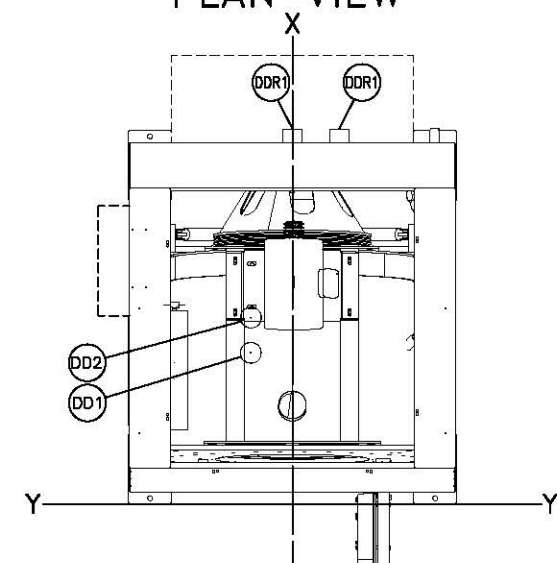

PLAN VIEW

BASELINE "Z" (REFERENCE FOR VERTICAL DIMENSIONS) CORRESPONDS TO TOP OF GROUT. SEE NOTE 3 AND 4.

REFERENCE LINE "Y" (REFERENCE FOR FRONT/REAR DIMENSIONS). SEE NOTE 3.

CENTERLINE "X" (REFERENCE FOR LEFT/RIGHT DIMENSIONS). SEE NOTE 3.

ITEM	LEGEND
W3	OPTIONAL THIRD (REUSE) WATER INLET, 1-1/2" NPT CONNECTION
S1	OPTIONAL AIR-OPERATED STEAM 1-1/4" NPT
L3	OPTIONAL 5 COMPARTMENT SUPPLY MANIFOLD
DDR2	DUAL DRAIN REAR TO REUSE 4" [102] HOSE CONNECTION
DDR1	DUAL DRAIN REAR TO SEWER 4" [102] HOSE CONNECTION
DD2	DUAL DRAIN CENTER TO REUSE 4" [102] HOSE CONNECTION
DD1	DUAL DRAIN CENTER TO SEWER 4" [102] HOSE CONNECTION
DD	DUAL DRAIN CENTER, VALVE
DC	CENTER DRAIN 4" [102] HOSE CONNECTION

- NOTES**
- AS OF THIS WRITING, THE MINIMUM CLEARANCE REQUIRED BY U.S. NATIONAL ELECTRIC CODES, FROM ELECTRIC BOX TO ANY OBJECT IS:  
 36 [914] IF OBJECT IS AN UNGROUNDED (INSULATED) WALL.  
 42 [1067] IF OBJECT IS A GROUNDED WALL (e.g. BARE CONCRETE, BRICK, ETC.)  
 48 [1219] IF OBJECT IS ANY LIVE PART.  
 CHECK LOCAL ELECTRIC CODES FOR FURTHER RESTRICTIONS.
  - CUSTOMER TO SUPPLY CIRCUIT BREAKER OR FUSED BRANCH CIRCUIT DISCONNECT (SAFETY) SWITCHES WITH LAG TYPE FUSES FROM POWER SOURCE TO MACHINE. A SEPARATE GROUND WIRE MUST BE CONNECTED FROM DISCONNECT TO EQUIPMENT.
  - BASELINE "Z" IS THE SAME FOR ALL MILNOR MACHINES AND IS SHOWN ON ALL DIMENSIONAL DRAWINGS. THE DISTANCE BETWEEN BASELINE "Z" AND THE FINISHED FLOOR MAY VARY (WITH CHANGES IN FLOOR HEIGHT) AS REQUIRED TO INSURE THAT BASELINE "Z" IS HORIZONTAL AND ALL COMPONENTS REQUIRING GROUT ARE SET ON A MINIMUM 1" [25] THICK GROUT BED.
  - USE REFERENCE LINES "X", "Y", AND "Z" TO LOCATE ALL SERVICE CONNECTIONS.
  - NUMBERS IN BRACKETS [ ] DENOTE DIMENSIONS IN MILLIMETERS.
  - ALL DIMENSIONS SHOWN ARE APPROXIMATE, SUBJECT TO NORMAL MANUFACTURING TOLERANCES, AND TO OCCASIONAL CHANGES WITHOUT NOTICE THROUGH REDESIGN AND/OR RELOCATION OF COMPONENTS, ETC. DO NOT USE FOR CONSTRUCTION UNLESS CERTIFIED, AND IN NO EVENT PRE-PIPE CLOSER THAN FIVE FEET FROM MACHINE. FACTORY MUST BE CONSULTED FOR DIMENSIONS IF MACHINE IS TO BE MOVED THROUGH NARROW OR LOW CORRIDORS OR OPENINGS.
- ATTENTION**  
 MOST REGULATORY AUTHORITIES (INCLUDING OSHA IN THE USA) HOLD THE OWNER/USER ULTIMATELY RESPONSIBLE TO MAINTAIN A SAFE WORKING ENVIRONMENT. ACCORDINGLY, THE OWNER/USER MUST RECOGNIZE ALL FORESEEABLE SAFETY HAZARDS, FURNISH SAFETY INSTRUCTIONS AND GUIDANCE TO ALL PERSONNEL WHO MAY COME IN CONTACT WITH THE INSTALLATION, AND PROVIDE ALL NECESSARY ADDITIONAL SAFETY GUARDS, FENCES, RESTRAINTS, DEVICES, ETC., NOT FURNISHED BY THE EQUIPMENT MANUFACTURER OR VENDOR.
- ATTENTION**  
 THE FLOOR AND/OR OTHER SUPPORT COMPONENTS MUST HAVE SUFFICIENT STRENGTH (AND RIGIDITY WITH DUE CONSIDERATION FOR NATURAL OR RESONANT FREQUENCY THEREOF) TO WITHSTAND THE FULLY LOADED WEIGHT OF THE MACHINE INCLUDING THE GOODS, THE WATER, AND ANY REPEATED SINUSOIDAL (ROTATING) FORCES GENERATED DURING ITS OPERATION. WRITE THE FACTORY FOR ADDITIONAL MACHINE DATA FOR USE BY A COMPETENT SOIL AND/OR STRUCTURAL ENGINEER.

MWF100J7, MWF100Z7 Options

BDMWF100JZAB  
2023404D

**MILNOR** PELLERIN MILNOR CORPORATION  
 P.O. Box 400 Kenner, LA 70063, USA, Phone 504/467-8581,  
 FAX 504/468-3084, Email: milnorinfo@milnor.com