

Published Manual Number/ECN: MAPMPX56AE/2023393A

- Publishing System: TPAS2
- Access date: 09/26/2023
- Document ECNs: NOT latest



Mechanical Parts

MP1640, MP1556, MP1656

MP1A50 CL, CR, L, R

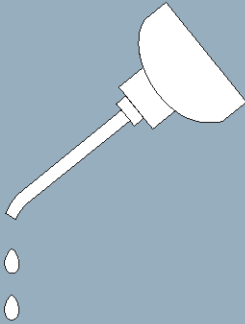

**Read the
separate
safety
manual
before
installing,
operating,
or servicing**



Table of Contents

MAPMPX56AE/23393A

Page	Description	Document
1	Limited Standard Warranty	BMP720097/2019036
2	How to Get the Necessary Repair Components	BIUUUD19/20081231
3	Tag Guidelines	BIUUUI02PP/20170824
9	Safety Placard Use and Placement - MP15xx, MPL5xx, MP16xx, MPL6xx, MP1Axx	BMP040036/2020275B
11	Safety Placard Use and Placement ISO - MP15xx, MPL5xx, MP16xx, MPL6xx, MP1Axx	BMP040037/2020275B
13	Torque Requirements for Fasteners	BIUUUM04/20180109
21	1. Housing Assemblies	
22	Guards, Covers, & Cosmetics	BMP110001/2021055B
25	Guards, Covers & Cosmetics - MP1A50	BMP110002/2012055B
28	Can Safety Stands and Diaphragm Bar	BMP110003/2020275A
31	Ship With	BMP110004/2020275B
33	Safety Unload Door	BMP110005/2020275A
36	Frame Assembly	BMP110006/2020275B
38	Foot Assembly	BMP110007/2020275B
39	Reuse Tank	BMP110008/2020275B
41	2. Hydraulic Piping and Assemblies	
42	Hydraulic Schematic MP1556, MP1640, MP1656, MP1A50	BMP110021/2023153B
44	Hydraulic Hoses - MP1556, MP1640 & MP1656	BMP110036/2012055B
51	Hydraulic Hoses MP1A50	BMP110045/2014533B
58	Hydraulic Tank - MP1540, MP1556, MP1640, MP1656	BMP110023/2014373A
64	Hydraulic Tank - MP1A50	BMP110044/2012052A
70	Hydraulic Main Pump: MP1A50 (Current), MP1540(before 08/2020), MP1640/1650/1556/1656(before 11/2019)	BMP110022/2020393A
75	Booster Pump	BMP110031/2015404A
78	Main Press Manifold	BMP110024/2014373A
82	Main Press Manifold - MP1A50	BMP110078/2012055A
86	Manifolds and Valves used with Booster Pump	BMP110030/2023393A
92	Pre-fill Pipe and Valve	BMP110025/2017222A
95	Oil Cooler - Air Cooled	BMP110033/2021055A
97	Oil Cooler - Water Cooled	BMP110032/2021055A
101	Hydraulic Schematic - Ram Command™ (Delicate Goods) Option	BMP140002/2022142A
104	RAM Command™ Option Adjustment	BMP1UA01/2022132
111	Delicate Goods Option	BMP170006/2017222A
114	Hydraulic Gages - MP1540, MP1556, MP1640, MP1650, MP1656, MP1A50	BMP110026/2012055A
116	Hydraulic Ram and Diaphragm	BMP110038/2021055A

Table of Contents, continued
MAPMPX56AE/23393A

Page	Description	Document
124	Ratchet Mechanism to Turn the Diaphragm - Components and Adjustment	BIPPM22/20130604
130	Load Chute Scupper with Adjustable Seal	BMP160024/2020275A
135	Receiving Chute and Can	BMP110040/2020275A
142	Counterbalance Valves and Tubing	BMP110041/2020275A
147	3. Pneumatic Piping and Assemblies	
148	Pneumatic Schematic	BMP110042/2020275B
151	4. Conveyor Assemblies	
152	Conveyor Bed	BMP110018/2020275B
154	Conveyor Unload End Assemblies	BMP110010/2020275B
162	Load End Rollers & Belt Tracking	BMP110011/2020275B

PELLERIN MILNOR CORPORATION

LIMITED STANDARD WARRANTY

We warrant to the original purchaser that MILNOR machines including electronic hardware/software (hereafter referred to as "equipment"), will be free from defects in material and workmanship for a period of one year from the date of shipment (unless the time period is specifically extended for certain parts pursuant to a specific MILNOR published extended warranty) from our factory with no operating hour limitation. This warranty is contingent upon the equipment being installed, operated and serviced as specified in the operating manual supplied with the equipment, and operated under normal conditions by competent operators.

Providing we receive written notification of a warranted defect within 30 days of its discovery, we will—at our option—repair or replace the defective part or parts, EX Factory (labor and freight specifically NOT included). We retain the right to require inspection of the parts claimed defective in our factory prior to repairing or replacing same. We will not be responsible, or in any way liable, for unauthorized repairs or service to our equipment, and this warranty shall be void if the equipment is tampered with, modified, or abused, used for purposes not intended in the design and construction of the machine, or is repaired or altered in any way without MILNOR's written consent.

Parts damaged by exposure to weather, to aggressive water, or to chemical attack are not covered by this warranty. For parts which require routine replacement due to normal wear—such as gaskets, contact points, brake and clutch linings, belts, hoses, and similar parts—the warranty time period is 90 days.

We reserve the right to make changes in the design and/or construction of our equipment (including purchased components) without obligation to change any equipment previously supplied.

ANY SALE OR FURNISHING OF ANY EQUIPMENT BY MILNOR IS MADE ONLY UPON THE EXPRESS UNDERSTANDING THAT MILNOR MAKES NO EXPRESSED OR IMPLIED WARRANTIES OF MERCHANTABILITY OR FITNESS FOR ANY PARTICULAR USE OR PURPOSE OR ANY OTHER WARRANTY IMPLIED BY LAW INCLUDING BUT NOT LIMITED TO REDHIBITION. MILNOR WILL NOT BE RESPONSIBLE FOR ANY COSTS OR DAMAGES ACTUALLY INCURRED OR REQUIRED AS A RESULT OF: THE FAILURE OF ANY OTHER PERSON OR ENTITY TO PERFORM ITS RESPONSIBILITIES, FIRE OR OTHER HAZARD, ACCIDENT, IMPROPER STORAGE, MIS-USE, NEGLIGENCE, POWER OR ENVIRONMENTAL CONTROL MALFUNCTIONS, DAMAGE FROM LIQUIDS, OR ANY OTHER CAUSE BEYOND THE NORMAL RANGE OF USE. REGARDLESS OF HOW CAUSED, IN NO EVENT SHALL MILNOR BE LIABLE FOR SPECIAL, INDIRECT, PUNITIVE, LIQUIDATED, OR CONSEQUENTIAL COSTS OR DAMAGES, OR ANY COSTS OR DAMAGES WHATSOEVER WHICH EXCEED THE PRICE PAID TO MILNOR FOR THE EQUIPMENT IT SELLS OR FURNISHES.

THE PROVISIONS ON THIS PAGE REPRESENT THE ONLY WARRANTY FROM MILNOR AND NO OTHER WARRANTY OR CONDITIONS, STATUTORY OR OTHERWISE, SHALL BE IMPLIED.

WE NEITHER ASSUME, NOR AUTHORIZE ANY EMPLOYEE OR OTHER PERSON TO ASSUME FOR US, ANY OTHER RESPONSIBILITY AND/OR LIABILITY IN CONNECTION WITH THE SALE OR FURNISHING OF OUR EQUIPMENT TO ANY BUYER.

BMP720097/19036

How to Get the Necessary Repair Components



This document uses Simplified Technical English.
Learn more at <http://www.asd-ste100.org>.

You can get components to repair your machine from the approved supplier where you got this machine. Your supplier will usually have the necessary components in stock. You can also get components from the Milnor® factory.

Tell the supplier the machine model and serial number and this data for each necessary component:

- The component number from this manual
- The component name if known
- The necessary quantity
- The necessary transportation requirements
- If the component is an electrical component, give the schematic number if known.
- If the component is a motor or an electrical control, give the nameplate data from the used component.

To write to the Milnor factory:

Pellerin Milnor Corporation
Post Office Box 400
Kenner, LA 70063-0400
UNITED STATES

Telephone: 504-467-2787
Fax: 504-469-9777
Email: parts@milnor.com

— End of BIUUUD19 —

Tag Guidelines for the Models Listed Below

MP1540CL	MP1540CR	MP1540L-	MP1540R-	MP1550CL	MP1550CR	MP1550L-
MP1550R-	MP1556CL	MP1556CR	MP1556L-	MP1556R-	MP1601CL	MP1601CR
MP1601LF	MP1601R-	MP1601RT	MP1602CL	MP1602CR	MP1602LF	MP1602RT
MP1603CL	MP1603CR	MP1603L-	MP1603R-	MP1604CL	MP1604CR	MP1604L-
MP1604R-	MP1640CL	MP1640CR	MP1640L-	MP1640R-	MP1656CL	MP1656CR
MP1656L-	MP1656R-	MP1A03CL	MP1A03CR	MP1A03L-	MP1A03R-	MP1A50CL
MP1A50CR	MP1A50L-	MP1A50R-	MP1A56CL	MP1A56CR	MP1A56L-	MP1A56R-

Notice 1: This information may apply to models in addition to those listed above. It applies to paper tags. It does not apply to the vinyl or metal safety placards, which must remain permanently affixed to the machine and replaced if no longer readable.

Paper tags on the machine provide installation guidelines and precautions. The tags can be tie-on or adhesive. You can remove tie-on tags and white, adhesive tags after installation. Yellow adhesive tags must remain on the machine.

Tag Guidelines for the Models Listed Below

The following entries explain the installation tags. Each entry includes: 1) the tag illustration, 2) the tag part number displayed at the bottom of the tag, and 3) the meaning of the tag.

Display or Action



Explanation

Read the manuals before proceeding. This symbol appears on most tags. The machine ships with safety, operator, and routine maintenance guides for customer use. Milnor dealer manuals for installing, servicing, and commissioning this machine are also available from the Milnor Parts department.



B2TAG88005: This carefully built product was tested and inspected to meet Milnor® performance and quality standards by (identification mark of tester).



B2TAG94078: Do not forklift here; do not jack here; do not step here—whichever applies.

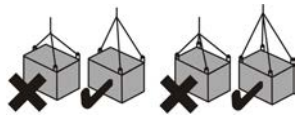

B2TAG94079: Rig for crane lifting (either 3-point or 4-point, depending on the number of lifting eyes provided) using a steep angle on the chains (closer to vertical than horizontal).



B2TAG94081: Motor must rotate in this direction. On single motor washer-extractors and centrifugal extractors, the drive motor must turn in this direction during draining and extraction. This tag is usually wrapped around a motor housing. If the motor turns in the opposite direction when the machine is first tested, the electrical hookup is incorrect and must be reversed as explained in the schematic manual.

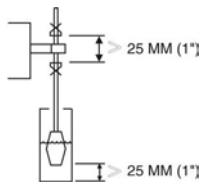

B2TAG94082: Maintain a 25 millimeter (1") minimum clearance between level float clips. Set low level so that the bottom of the float is always at least 25 millimeters (1") above the bottom of the float tube.

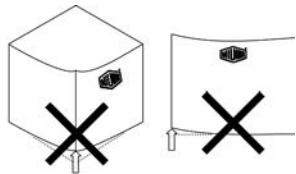

B2TAG94084: Do not lift from one corner of the machine, as this can cause the frame to rack, damaging it.

Display or Action



Explanation

B2TAG94102 shown—others similar: Match up the components with this number. These tags are used to pair up electrical or hose connections between major components of a machine shipped dis-assembled.

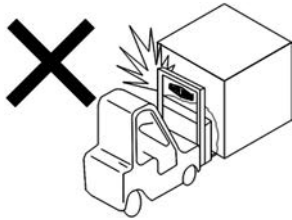

B2TAG94118: Do not strike shipping container during forklifting. Fragile components inside.

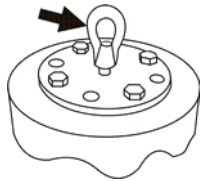

B2TAG98037: Read the installation instructions. Do not attempt to lift the machine with this component. Do not remove this component unless the ram cylinder is mounted to the top plate, the ram is raised fully **and the platen safety bars are installed**. Use this component to raise the ram cylinder for mounting, during installation.

35 - 40 psi
241316 - 275790 Pa (N/m²)



B2TAG98039: Verify that discharge door pressure is within the range shown.

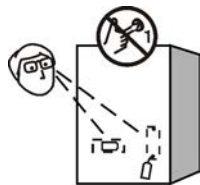

B2T2001028: Look for tags inside the machine. These tags may identify shipping restraints to be removed or components to be installed. Do not start the machine until these actions are completed.



B2T2002013: Do not start the machine until shipping restraints are removed. This tag will appear on the outside of the machine to alert you to the presence of internal shipping restraints. A tag will also appear on the restraint to help identify it. Most, but not all shipping restraints display the color red. Some shipping restraints are also safety stands. Do not discard these.

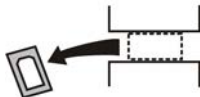

Tag Guidelines for the Models Listed Below

Display or Action

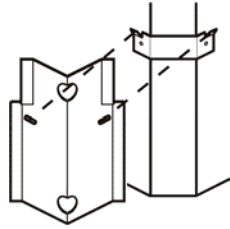

Explanation

B2T2002016: Store safety stands as shown when not in use.



B2T2003014: Make sure that you use the specified hydraulic oil.

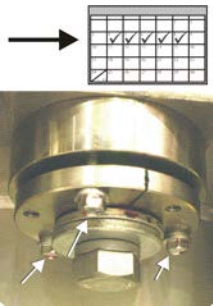

B2T2004028: Read the service instructions. Retighten the can bushing bolts to the torque shown after each of the first five days of operation following installation.

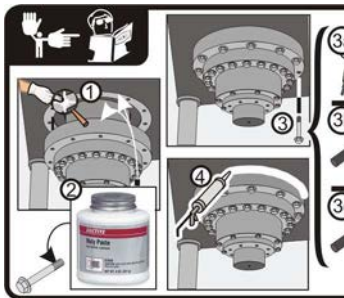

B2T2007017: Read the installation instructions. When mounting the ram, use LocTite moly paste on mounting surfaces. Torque the bolts three times as shown.

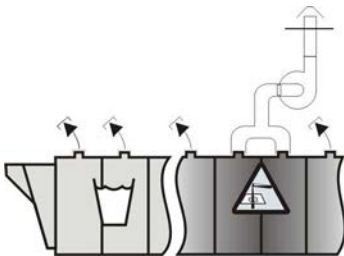

B2T2008001: Read the installation instructions. Remove temporary vent covers. Install a powered vent unit on the oxidation zone modules and a separate powered vent unit on the finish zone module and adjacent press, if there is one.

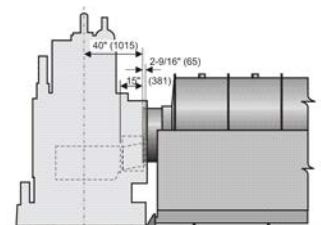

B2T2008006: When installing a G3 CBW tunnel washer behind a 1-stage press, maintain the dimensions shown.

Display or Action



Explanation

B2T2009017: Lift the press frame from the eye bolts on the four columns. Never attempt to lift the press from the eye bolt on top of the ram cylinder. This eye bolt is used to raise the ram into position.



B2T2010023: Set the press frame in accordance with this instruction and the installation manual.

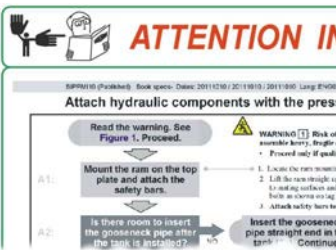

B2T2011015: Attach hydraulic components as explained. This procedure is critical.

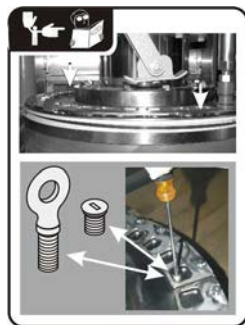

B2T2012012: When you remove the safety bar eye bolts for automatic operation, install the O-ring plugs fully in the two threaded holes.



B2T2016041: Find pressure gauge instructions here.

Tag Guidelines for the Models Listed Below

Display or Action



Explanation

B2T2017010: All hydraulic oil added to the 1-station press must be passed through a 10 micron filter.

— End of BIUUUI02 —

Safety Placard Use and Placement

MP15xx, MP16xx, MP1Axx, MPL5xx, MPL6xx, MP1Axx

BMP040036/2020275B
(Sheet 1 of 2)



Pellerin Milnor Corporation
P. O. Box 400, Kenner, LA 70063-0400

Litho in U.S.A.

Notes:

1. Replace placard immediately, if removed or unreadable.
2. Approximate locations of placards are shown. Mounting holes are provided on machine. If aluminum placard use #8 self-tapping screws.

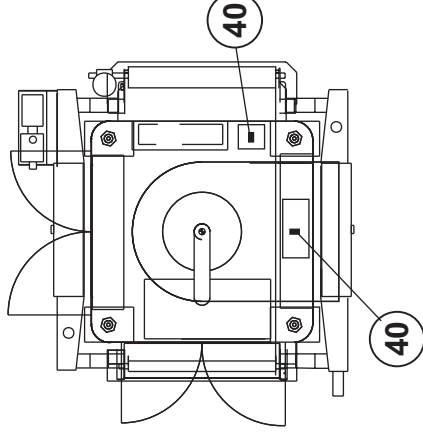
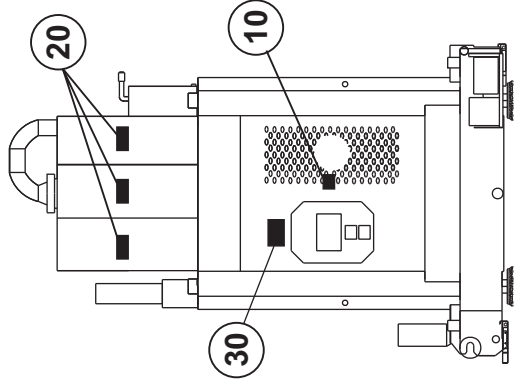

REAR VIEW

PLAN VIEW

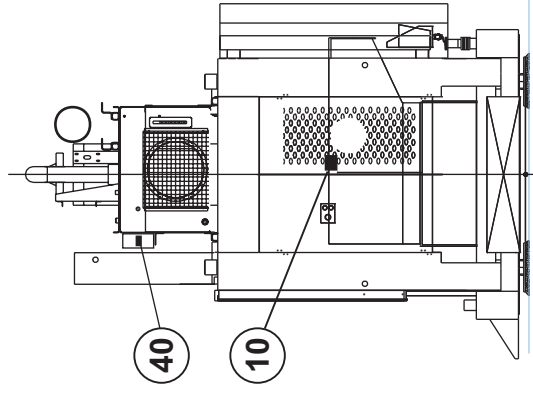

LEFT VIEW

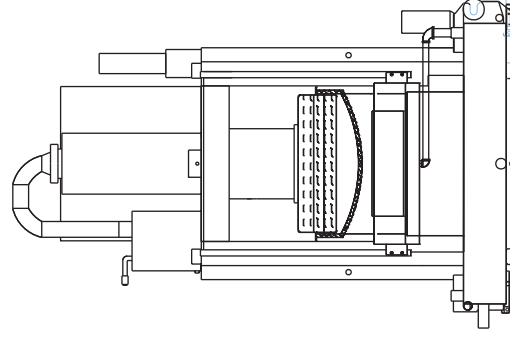

FRONT VIEW

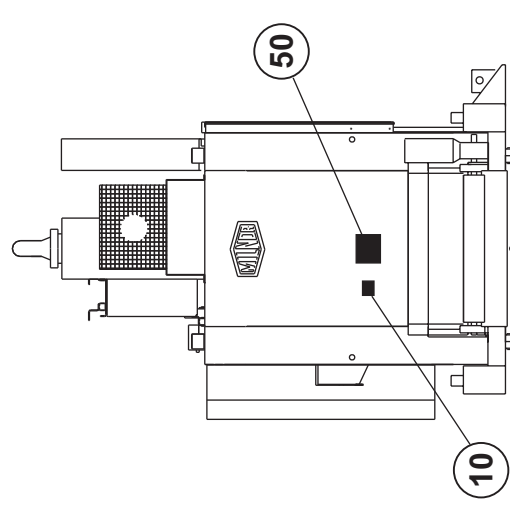

RIGHT VIEW

Safety Placard Use and Placement

MP15xx, MP16xx, MP1Axx, MP5xx, MP6xx, MP1Axx

BMP040036/2020275B
(Sheet 2 of 2)



Pellerin Milnor Corporation
P. O. Box 400, Kenner, LA 70063-0400

Litho in U.S.A.

Parts List—Safety Placard Placement

Find the correct assembly first, then find the needed components. The item letters (A, B, C, etc.) assigned to assemblies are referred to in the "Used In" column to identify which components belong to an assembly. The item numbers (1, 2, 3, etc.) assigned to components relate the parts list to the illustration.

Used In	Item	Part Number	Description	Comments
			-----COMPONENTS-----	
all	10	01 10668A	NPLT:PRESS DOOR HAZARD-TCATA	
all	20	01 10377A	NPLT:ELEC HAZARD LG-TCATA	
all	30	01 10699A	NPLT:SERV HZRD-PLYEST-TCATA	
all	40	01 10375B	NPLT:ELEC HAZARD SMALL-TCATA	
all	50	01 10634A	NPLT:CONVEYOR HAZARDS-TCATA	

Safety Placard Use and Placement ISO

MP15xx, MP16xx, MPL5xx, MPL6xx, MP1Axx

BMP040037/2020275B
(Sheet 1 of 2)



Pellerin Milnor Corporation
P. O. Box 400, Kenner, LA 70063-0400

Litho in U.S.A.

ISO Placards shown on this page

Notes:

1. Replace placard immediately, if removed or unreadable.
2. Approximate locations of placards are shown. Mounting holes are provided on machine. If aluminum placard use #8 self-tapping screws.

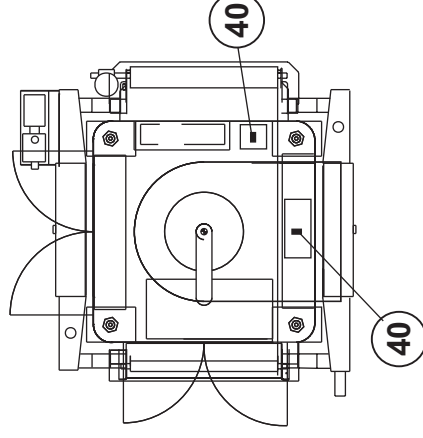
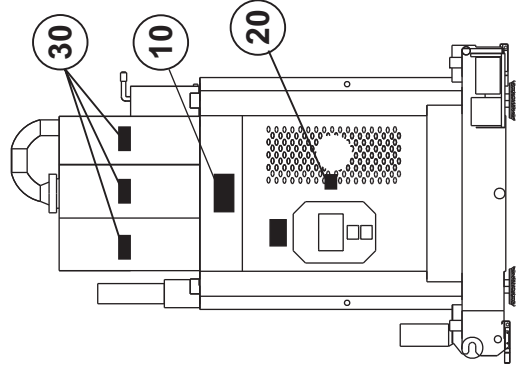

REAR VIEW

PLAN VIEW

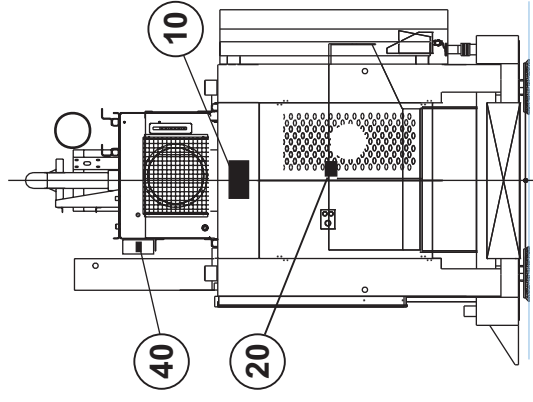

LEFT VIEW

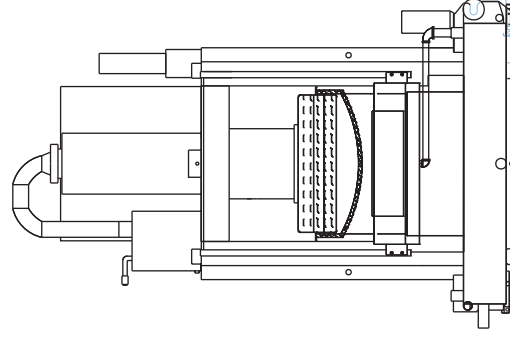

FRONT VIEW

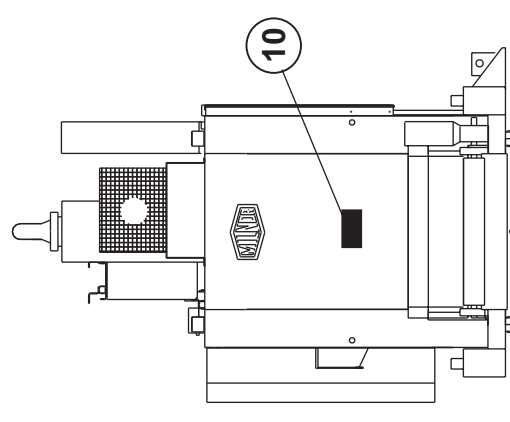

RIGHT VIEW

Safety Placard Use and Placement ISO

BMP040037/2020275B
(Sheet 2 of 2)



Pellerin Milnor Corporation
P. O. Box 400, Kenner, LA 70063-0400

Litho in U.S.A.

Parts List—Safety Placard Placement

Find the correct assembly first, then find the needed components. The item letters (A, B, C, etc.) assigned to assemblies are referred to in the "Used In" column to identify which components belong to an assembly. The item numbers (1, 2, 3, etc.) assigned to components relate the parts list to the illustration.

Used In	Item	Part Number	Description	Comments
			-----COMPONENTS-----	
all	10	01 10668X	NPLT:S.PRESS WARNINGS-ISO	
all	20	01 10577X	NPLT:PRESS WRNG CRUSHING-ISO	
all	30	01 10377	NPLTE:"WARNING" 4X4	
all	40	01 10375	NPLTE:"WARNING" 2X2	

Torque Requirements for Fasteners



This document uses Simplified Technical English. Learn more at <http://www.asd-ste100.org>.

The document about the assembly gives the torque requirements for other fasteners. **If fastener torque specifications or threadlocker requirements in an assembly document are different from this document, use the assembly document.**

Figure 1: The Bolts in Milnor® Equipment

The Marks on Bolt Heads	Legend
	<p>A. SAE Grades 1 and 2, ASTM A307, and stainless steel</p> <p>B. Grade BC, ASTM A354</p> <p>C. SAE Grade 5, ASTM A449</p> <p>D. SAE Grade 8 and ASTM A354 BD</p>

1. Torque Values

These tables give the standard dimension, grade, threadlocker, and torque requirements for fasteners frequently used on Milnor® equipment.

Note 1: Data from the Pellerin Milnor® Corporation “Bolt Torque Specification” (bolt_torque_milnor.xls/2002096).

1.1. Fasteners Made of Carbon Steel

1.1.1. Without a Threadlocker

Table 1: Torque Values for Standard Fasteners with Maximum 5/16-inch Diameters and No Lubricant

Dimension	The Grade of the Bolt							
	Grade 2		Grade 5		Grade 8		Grade BC	
	Pound-Inches	N-m	Pound-Inches	N-m	Pound-Inches	N-m	Pound-Inches	N-m
1/4 x 20	66	7	101	11	143	16	126	14
1/4 x 28	76	9	116	13	163	18	--	--
5/16 x 18	136	15	209	24	295	33	258	29
5/16 x 24	150	17	232	26	325	37	--	--

Torque Requirements for Fasteners

Table 2: Torque Values for Standard Fasteners Larger Than 5/16-inch Diameters and No Lubricant

Dimension	The Grade of the Bolt							
	Grade 2		Grade 5		Grade 8		Grade BC	
	Pound-feet	N-m	Pound-feet	N-m	Pound-feet	N-m	Pound-feet	N-m
3/8 x 16	20	27	31	42	44	59	38	52
3/8 x 24	23	31	35	47	50	68	--	--
7/16 x 14	32	43	49	66	70	95	61	83
7/16 x 20	36	49	55	75	78	105	--	--
1/2 x 13	49	66	75	102	107	145	93	126
1/2 x 20	55	75	85	115	120	163	--	--
9/16 x 12	70	95	109	148	154	209	134	182
9/16 x 18	78	106	121	164	171	232	--	--
5/8 x 11	97	131	150	203	212	287	186	252
5/8 x 18	110	149	170	231	240	325	--	--
3/4 x 10	172	233	266	361	376	510	329	446
3/4 x 16	192	261	297	403	420	569	--	--
7/8 x 9	167	226	429	582	606	821	531	719
7/8 x 14	184	249	473	641	668	906	--	--
1 x 8	250	339	644	873	909	1232	796	1079
1 x 12	274	371	704	954	994	1348	--	--
1 x 14	281	381	723	980	1020	1383	--	--
1 1/8 x 7	354	480	794	1077	1287	1745	1126	1527
1 1/8 x 12	397	538	891	1208	1444	1958	--	--
1 1/4 x 7	500	678	1120	1519	1817	2464	1590	2155
1 1/4 x 12	553	750	1241	1682	2012	2728	--	--
1 3/8 x 6	655	888	1469	1992	2382	3230	2085	2827
1 3/8 x 12	746	1011	1672	2267	2712	3677	--	--
1 1/2 x 6	869	1178	1949	2642	3161	4286	2767	3751
1 1/2 x 12	979	1327	2194	2974	3557	4822	--	--

Table 3: Torque Values for Plated Fasteners with Maximum 5/16-inch Diameters and No Lubricant

Dimension	The Grade of the Bolt							
	Grade 2		Grade 5		Grade 8		Grade BC	
	Pound-Inches	N-m	Pound-Inches	N-m	Pound-Inches	N-m	Pound-Inches	N-m
1/4 x 20	49	6	76	9	107	12	95	11
1/4 x 28	56	6	88	10	122	14	--	--
5/16 x 18	102	12	156	18	222	25	193	22
5/16 x 24	113	13	174	20	245	28	--	--

Table 4: Torque Values for Plated Fasteners Larger Than 5/16-inch Diameters and No Lubricant

Dimension	The Grade of the Bolt							
	Grade 2		Grade 5		Grade 8		Grade BC	
	Pound-feet	N-m	Pound-feet	N-m	Pound-feet	N-m	Pound-feet	N-m
3/8 x 16	15	20	23	31	33	44	29	38
3/8 x 24	17	23	26	35	37	49	--	--
7/16 x 14	24	32	37	50	52	71	46	61
7/16 x 20	27	36	41	55	58	78	--	--
1/2 x 13	37	49	56	76	80	106	70	93
1/2 x 20	41	55	64	85	90	120	--	--
9/16 x 12	53	70	81	110	115	153	101	134
9/16 x 18	59	79	91	122	128	174	--	--
5/8 x 11	73	97	113	150	159	212	139	186
5/8 x 18	83	110	127	172	180	240	--	--
3/4 x 10	129	173	200	266	282	376	246	329
3/4 x 16	144	192	223	297	315	420	--	--
7/8 x 9	125	166	322	430	455	606	398	531
7/8 x 14	138	184	355	474	501	668	--	--
1 x 8	188	250	483	644	682	909	597	796
1 x 12	205	274	528	716	746	995	--	--
1 x 14	210	280	542	735	765	1037	--	--
1 1/8 x 7	266	354	595	807	966	1288	845	1126
1 1/8 x 12	298	404	668	890	1083	1444	--	--
1 1/4 x 7	375	500	840	1120	1363	1817	1192	1590
1 1/4 x 12	415	553	930	1261	1509	2013	--	--
1 3/8 x 6	491	655	1102	1470	1787	2382	1564	2085
1 3/8 x 12	559	758	1254	1672	2034	2712	--	--
1 1/2 x 6	652	870	1462	1982	2371	3161	2075	2767
1 1/2 x 12	733	994	1645	2194	2668	3557	--	--

1.1.2. With a Threadlocker

Table 5: Threadlocker by the Diameter of the Bolt (see Note 2)

LocTite Product	Dimension			
	1/4-inch	1/4- to 5/8-inch	5/8- to 7/8-inch	1-inch +
LocTite 222	OK			
LocTite 242		OK		
LocTite 262			OK	
LocTite 272			High temperature	
LocTite 277				OK

Note 2: The acceptable bolt size ranges for various LocTite® threadlocking products is the LocTite manufacturer's **general** recommendation. Specific applications sometime require that a LocTite product is applied to a bolt size outside the ranges shown here. For example, Milnor specifies LocTite 242 for use on certain 1" bolt applications and has confirmed this usage with the LocTite manufacturer. You may see variances such as this in the documentation for specific machine assemblies.

Torque Requirements for Fasteners

Table 6: Torque Values if You Apply LocTite 222

Dimension	The Grade of the Bolt							
	Grade 2		Grade 5		Grade 8		Grade BC	
	Pound-inches	N-m	Pound-inches	N-m	Pound-inches	N-m	Pound-inches	N-m
1/4 x 20	60	7	96	11	132	15	108	12
1/4 x 28	72	8	108	12	144	16	--	--

Table 7: Torque Values if You Apply LocTite 242

Dimension	The Grade of the Bolt							
	Grade 2		Grade 5		Grade 8		Grade BC	
	Pound-feet	N-m	Pound-feet	N-m	Pound-feet	N-m	Pound-feet	N-m
5/16 x 18	11	15	17	23	25	34	22	30
5/16 x 24	13	18	19	26	27	37	27	37
3/8 x 16	20	27	31	42	44	60	38	52
3/8 x 24	23	31	35	47	50	68	--	--
7/16 x 14	32	43	49	66	70	95	61	83
7/16 x 20	36	49	55	75	78	106	--	--
1/2 x 13	49	66	75	102	107	145	93	126
1/2 x 20	55	75	85	115	120	163	--	--
9/16 x 12	70	95	109	148	154	209	134	182
9/16 x 18	78	106	121	164	171	232	--	--
5/8 x 11	97	132	150	203	212	287	186	252
5/8 x 18	110	149	170	230	240	325	--	--

Table 8: Torque Values if You Apply LocTite 262

Dimension	The Grade of the Bolt							
	Grade 2		Grade 5		Grade 8		Grade BC	
	Pound-feet	N-m	Pound-feet	N-m	Pound-feet	N-m	Pound-feet	N-m
3/4 x 10	155	210	240	325	338	458	296	401
3/4 x 16	173	235	267	362	378	512	--	--
7/8 x 9	150	203	386	523	546	740	477	647
7/8 x 14	165	224	426	578	601	815	--	--

Table 9: Torque Values if You Apply LocTite 272 (High-Temperature)

Dimension	The Grade of the Bolt							
	Grade 2		Grade 5		Grade 8		Grade BC	
	Pound-feet	N-m	Pound-feet	N-m	Pound-feet	N-m	Pound-feet	N-m
1 x 8	350	475	901	1222	1272	1725	1114	1510
1 x 12	383	519	986	1337	1392	1887	--	--
1 x 14	393	533	1012	1372	1428	1936	--	--
1-1/8 x 7	496	672	1111	1506	1802	2443	1577	2138
1-1/8 x 12	556	754	1247	1691	2022	2741	--	--
1-1/4 x 7	700	949	1568	2126	2544	3449	2226	3018
1-1/4 x 12	774	1049	1737	2355	2816	3818	--	--
1-3/8 x 6	917	1243	2056	2788	3335	4522	2919	3958
1-3/8 x 12	1044	1415	2341	3174	3797	5148	--	--
1-1/2 x 6	1217	1650	2729	3700	4426	6001	3873	5251
1-1/2 x 12	1369	1856	3071	4164	4980	6752	--	--

Table 10: Torque Values if You Apply LocTite 277

Dimension	The Grade of the Bolt							
	Grade 2		Grade 5		Grade 8		Grade BC	
	Pound-feet	N-m	Pound-feet	N-m	Pound-feet	N-m	Pound-feet	N-m
1 x 8	325	441	837	1135	1181	1601	1034	1402
1 x 12	356	483	916	1242	1293	1753	--	--
1 x 14	365	495	939	1273	1326	1798	--	--
1-1/8 x 7	461	625	1032	1399	1674	2270	1464	1985
1-1/8 x 12	516	700	1158	1570	1877	2545	--	--
1-1/4 x 7	650	881	1456	1974	2362	3202	2067	2802
1-1/4 x 12	719	975	1613	2187	2615	3545	--	--
1-3/8 x 6	851	1154	1909	2588	3097	4199	2710	3674
1-3/8 x 12	970	1315	2174	2948	3526	4781	--	--
1-1/2 x 6	1130	1532	2534	3436	4110	5572	3597	4877
1-1/2 x 12	1271	1723	2852	3867	4624	6269	--	--

1.2. Stainless Steel Fasteners

Table 11: Torque Values for Stainless Steel Fasteners 5/16-inch and Smaller

Dimension	316 Stainless		18-8 Stainless		18-8 Stainless with Loctite 767	
	Pound-Inches	N-m	Pound-Inches	N-m	Pound-Inches	N-m
1/4 x 20	79	9	76	9	45	5
1/4 x 28	100	11	94	11	56	6
5/16 x 18	138	16	132	15	79	9
5/16 x 24	148	17	142	16	85	10

Table 12: Torque Values for Stainless Steel Fasteners Larger Than 5/16-inch

Dimension	316 Stainless		18-8 Stainless		18-8 Stainless with Loctite 767	
	Pound-feet	N-m	Pound-feet	N-m	Pound-feet	N-m
3/8 x 16	21	28	20	27	12	16
3/8 x 24	23	31	22	29	13	18
7/16 x 14	33	44	31	42	19	25
7/16 x 20	35	47	33	45	20	27
1/2 x 13	45	61	43	58	26	35
1/2 x 20	47	64	45	61	27	37
9/16 x 12	59	81	57	77	34	46
9/16 x 18	66	89	63	85	38	51
5/8 x 11	97	131	93	125	56	75
5/8 x 18	108	150	104	141	62	84
3/4 x 10	132	179	128	173	77	104
3/4 x 16	130	176	124	168	75	101
7/8 x 9	203	275	194	263	116	158
7/8 x 14	202	273	193	262	116	157
1 x 8	300	406	287	389	172	233
1 x 14	271	367	259	351	156	211
1-1/8 x 7	432	586	413	560	248	336
1-1/8 x 12	408	553	390	529	234	317
1-1/4 x 7	546	740	523	709	314	425
1-1/4 x 12	504	683	480	651	288	390
1-1/2 x 6	930	1261	888	1204	533	722
1-1/2 x 12	732	992	703	953	422	572

2. Preparation



WARNING 2: Fire Hazard—Some solvents and primers are flammable.

- Use threadlocker and primers with sufficient airflow.
 - Do not use flammable material near ignition sources.
1. Clean all threads with a wire brush or a different tool.
 2. Remove the grease from the fasteners and the mating threads with solvent. Make the parts dry.

Note 3: Loctite 7649 Primer™ or standard solvents will remove grease from parts.
 3. Apply a spray of Loctite 7649 Primer™ or equal on the fasteners and the mating threads. Let the primer dry for one minute minimum.

3. How to Apply a Threadlocker



CAUTION 3: Malfunction Hazard—Heat, vibration, or mechanical shocks can let the fasteners loosen if you do not apply the threadlocker correctly. Loose fasteners can cause malfunctions of the equipment.

- Read the threadlocker manufacturer's instructions and warnings. Obey these instructions.

Apply the threadlocker only to the areas where the fastener threads and the mating threads engage.

Figure 2: Blind Hole

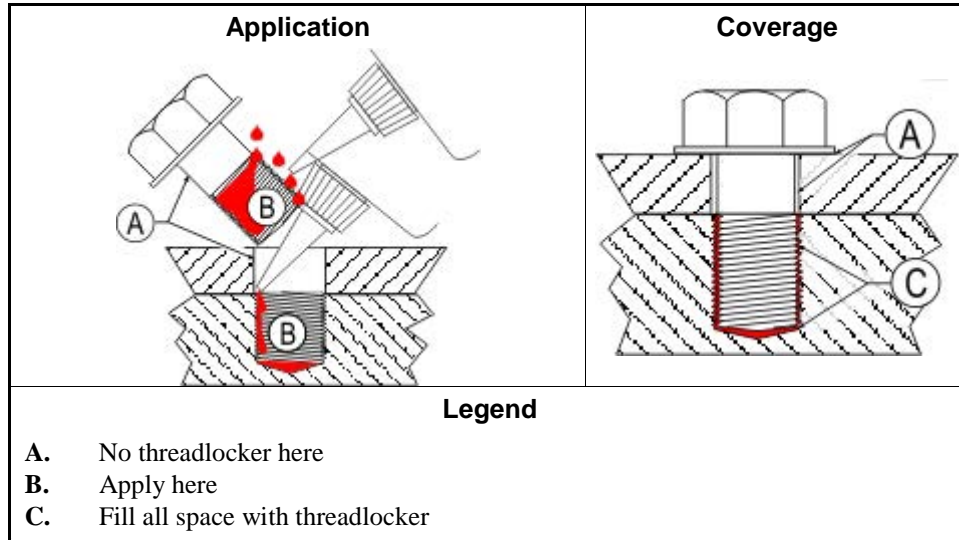

3.1. Blind Holes

1. Apply the threadlocker down the threads to the bottom of the hole.
2. Apply the threadlocker to the bolt.
3. Tighten the bolt to the value shown in the correct table ([Table 5](#) to [Table 11](#)).

3.2. Through Holes

1. Put the bolt through the assembly.
2. Apply the threadlocker only to the bolt thread area that will engage the nut.
3. Tighten the bolt to the value shown in the correct table ([Table 5](#) to [Table 11](#)).

Figure 3: Through Hole

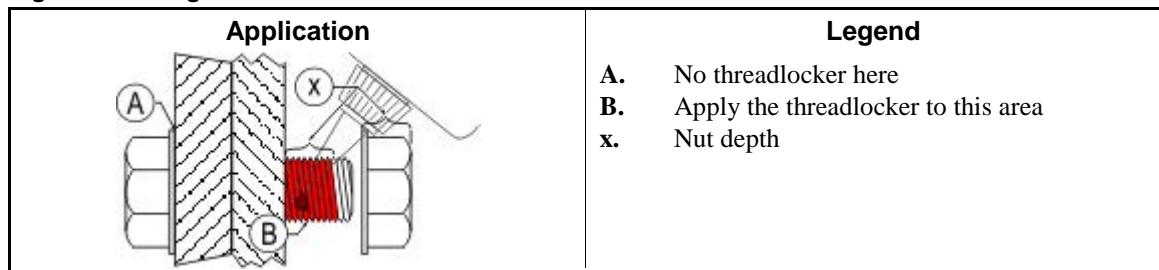

- 3.3. Disassembly**—For high-strength threadlocker, apply heat for five minutes. Disassemble with hand tools while the parts are hot.

For low-strength and moderate-strength threadlocker, disassemble with hand tools.

Figure 4: Disassembly

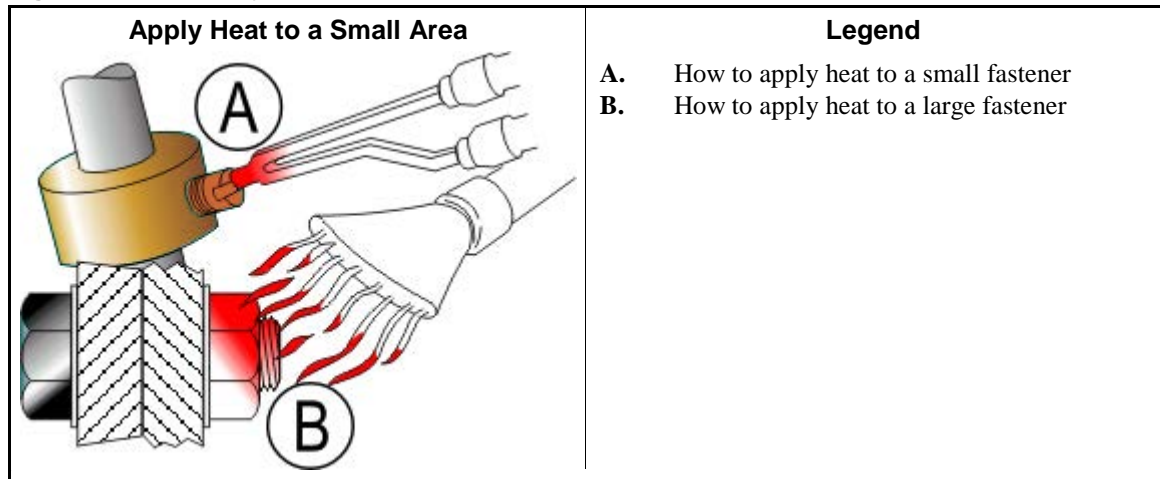

— End of BIUUM04 —

Housing Assemblies

1

Guards, Covers, & Cosmetics
MP1540, MP1556, MP1640, MP1650, MP1656
MPL550, MPL556, MPL640, MPL650, MPL656

BMP110001/2021055B
(1/3)



Pellerin Milnor Corporation
P. O. Box 400, Kenner, LA 70063-0400

Litho in U.S.A.

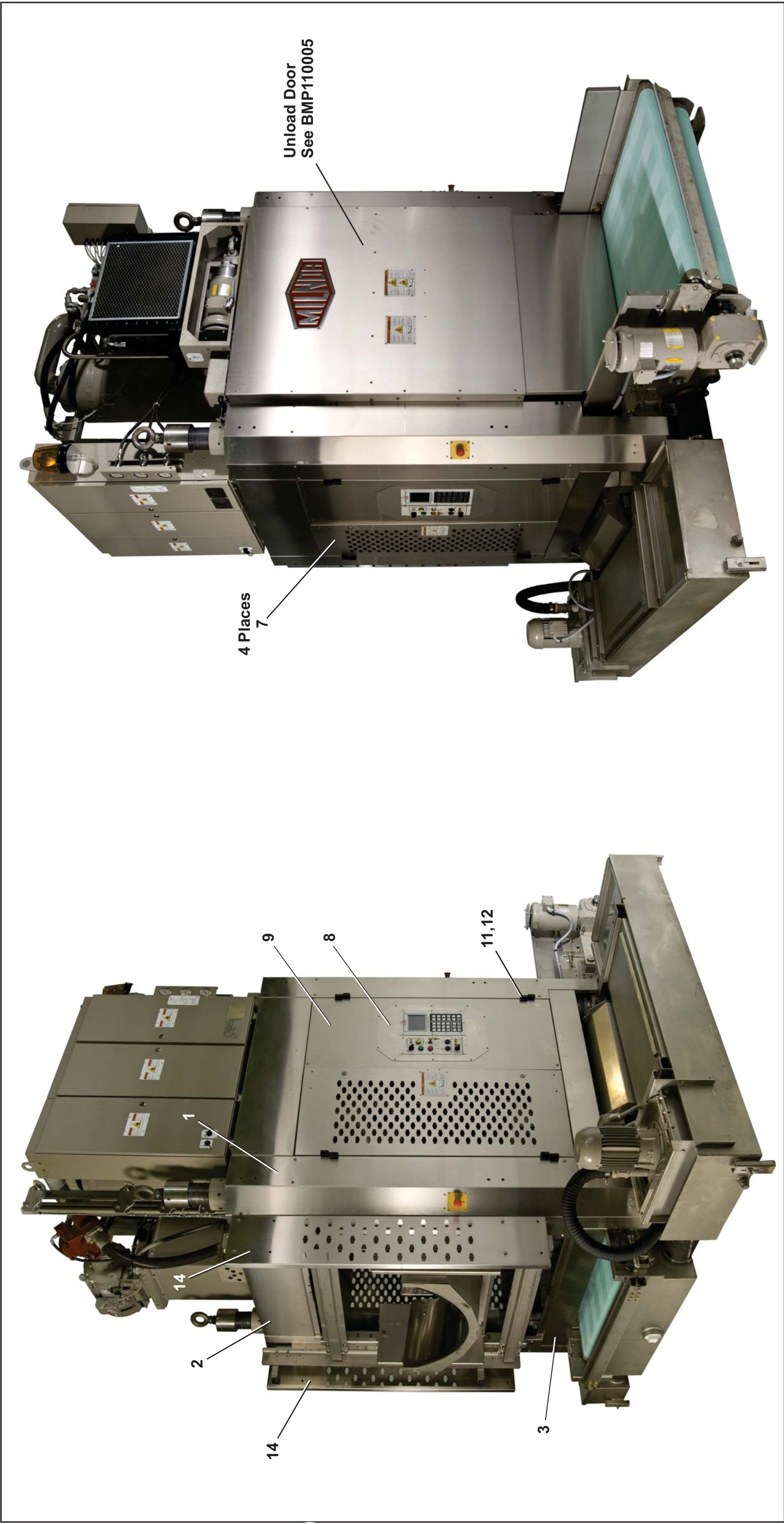



Pellerin Milnor Corporation
 P. O. Box 400, Kenner, LA 70063-0400

Litho in U.S.A.

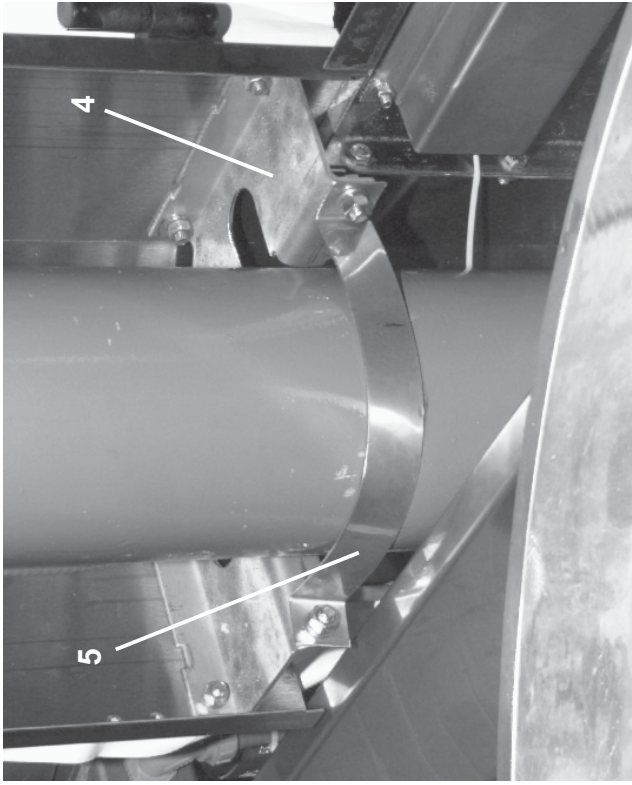

Typical Cosmetic to Frame Connections

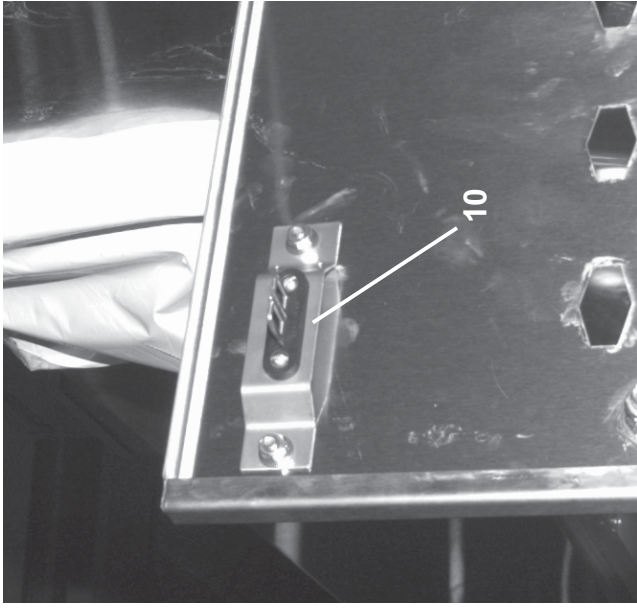

Typical Door Striker Mounting

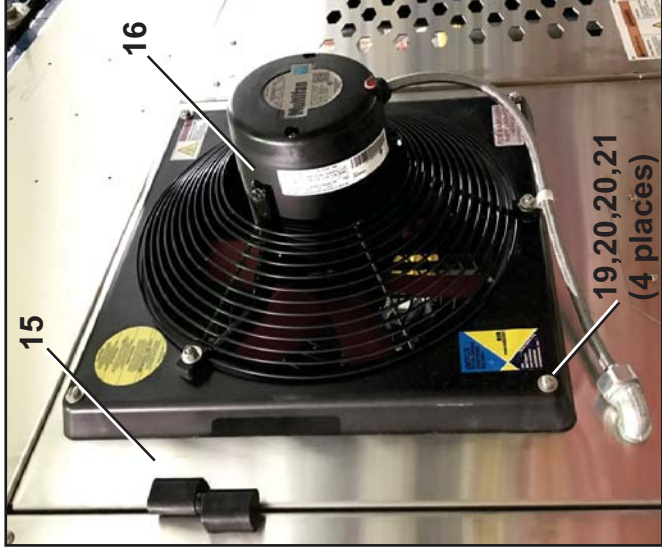

Door with Fan



Safety Stand Storage Bracket
 (Safety Stands, See BMP110003)

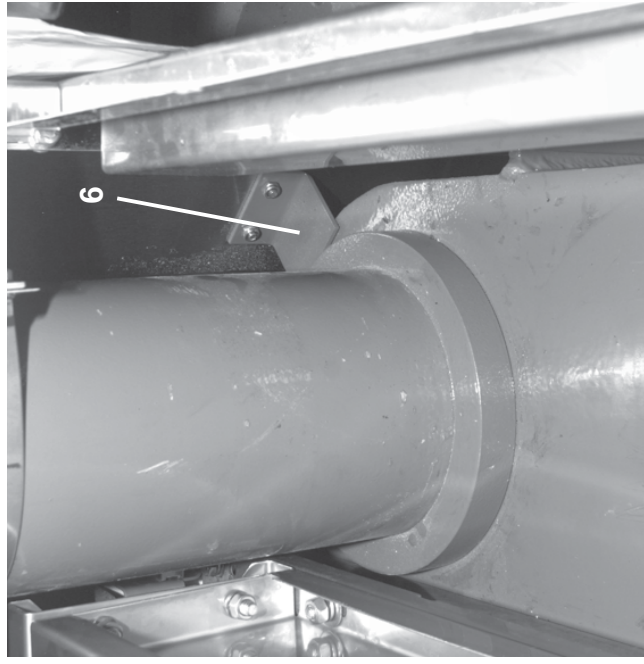

Guards, Covers, & Cosmetics
MP1540, MP1556, MP1640, MP1650, MP1656
MPL550, MPL556, MPL640, MPL650, MPL656

BMP110001/2021055B
 (3 / 3)



Pellerin Milnor Corporation
 P. O. Box 400, Kenner, LA 70063-0400

Litho in U.S.A.

Used In		Item	Part Number	Description	Comments
<p>Parts List—Guards, Covers, & Cosmetics Find the correct assembly first, then find the needed components. The item letters (A, B, C, etc.) assigned to assemblies are referred to in the "Used In" column to identify which components belong to an assembly. The item numbers (1, 2, 3, etc.) assigned to components relate the parts list to the illustration.</p>					
	A	ACS10000	SSPRESS COSMETIC ASSY	ASSEMBLIES	MP1540,MP1640,MP1650 MPL640, MPL650
	B	ACS10000A	COSMETIC ASSY W/ BOOSTER PUMP		MP1556,MP1656 MPL556, MPL656
	C	ACS10019A	DOOR W/FAN ON LF SIDE-MP15/16 R,CR		All
-----COMPONENTS-----					
all	1	07 10200	COSMETIC COVER CORNER		
all	2	07 10210	COSM TOP DOOR FRAME		
all	3	07 10284	COSM CONV LOADEND FRAME		
all	4	07 10205	COSM CORNER ATTACH BRKT		
all	5	07 10206	COSMETIC CORNER STRAP		
all	6	07 10200B	COSMETIC CORNER SUPPORT BRKT		
all	7	07 10246	SSPRESS DOOR PANEL		
all	8	07 10255A	SPRESS FLT REC SWPNL		
all	9	07 10256	SSPRESS DOOR-CTRL PANNEL		
all	10	07 10363	DOOR STRIKER MTG BRKT		
all	11	27A115	OFFSET HINGE RGTHD FREESWING		
all	12	27A116	OFFSET HINGE LFTHD FREESWING		
all	13	07 10204	SAFETY STAND HANGER-SSPRESS		
all	14	07 10018	LOADCHUTE GUARD 7632		
all	15	07 10616	SSPRESS DOOR-CNTRL PANEL-FAN-RT		
all	15	07 10616A	SSPRESS DOOR-CNTRL PANEL-FAN-LFT		
all	16	13AF210071	FAN 2100 CFM 240V 60HZ		
all	17	07 10680	FAN GUARD SS PRESS		
all	18	07 10619	PRESS FAN GUARD MNT		
all	19	15N200	FILMACSCR 1/4-20UNCX2 SS18-8 S		
all	20	15U185	FLATWASHER(USS STD) 1/4" ZNC P		
all	21	15G164NE	HEXLOKNUIT NYL 1/4-20 UNC2A SS.		
all	22	15K031	BUTSOKCAPSCR 1/4-20X1/2 SS18-8		



Pellerin Milnor Corporation
P. O. Box 400, Kenner, LA 70063-0400

Litho in U.S.A.

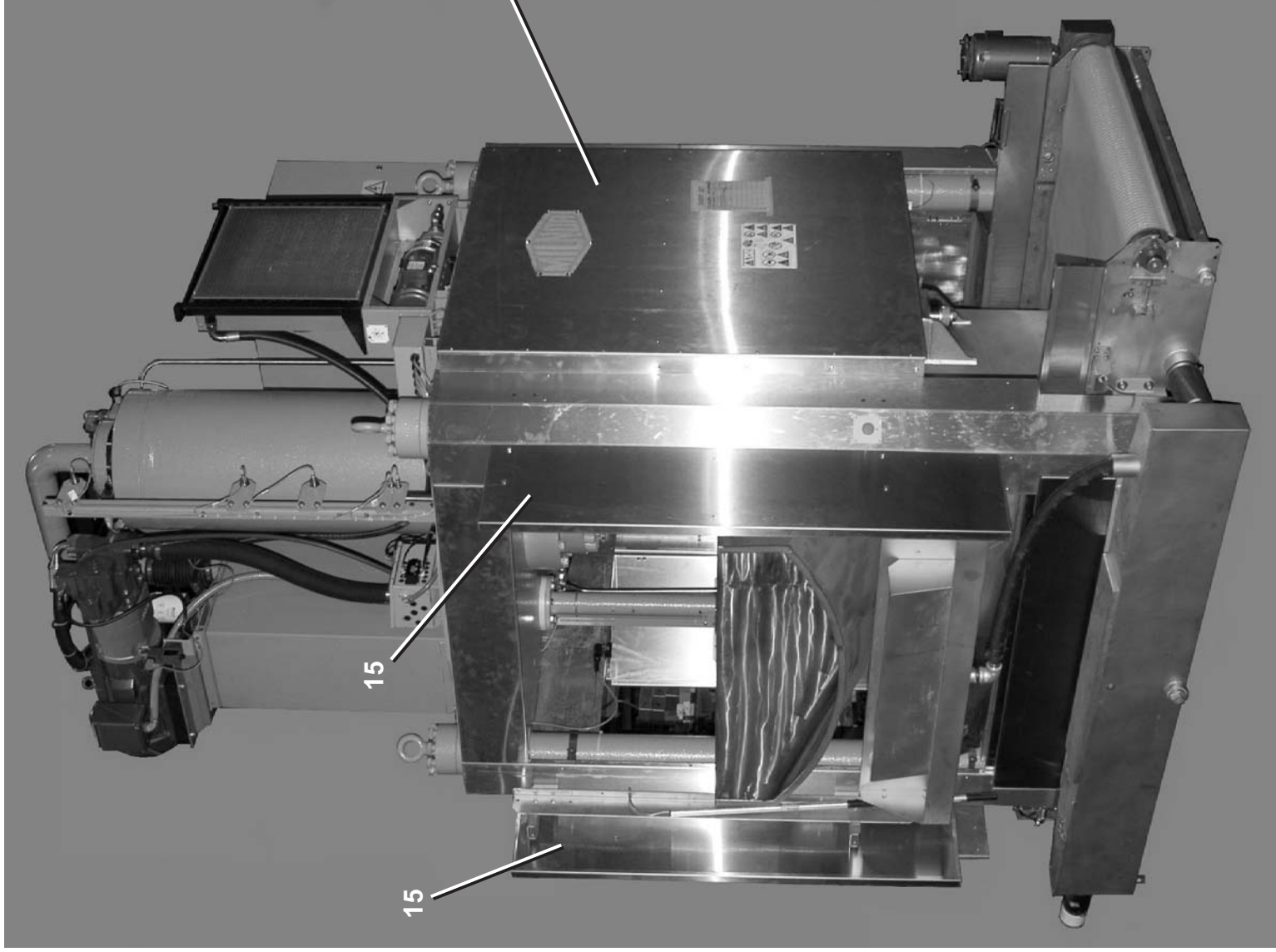

Unload
Door
Assembly,
See
BMP110005.



Load
Chute
Guards
15

Safety
Stands,
See
BMP110003.

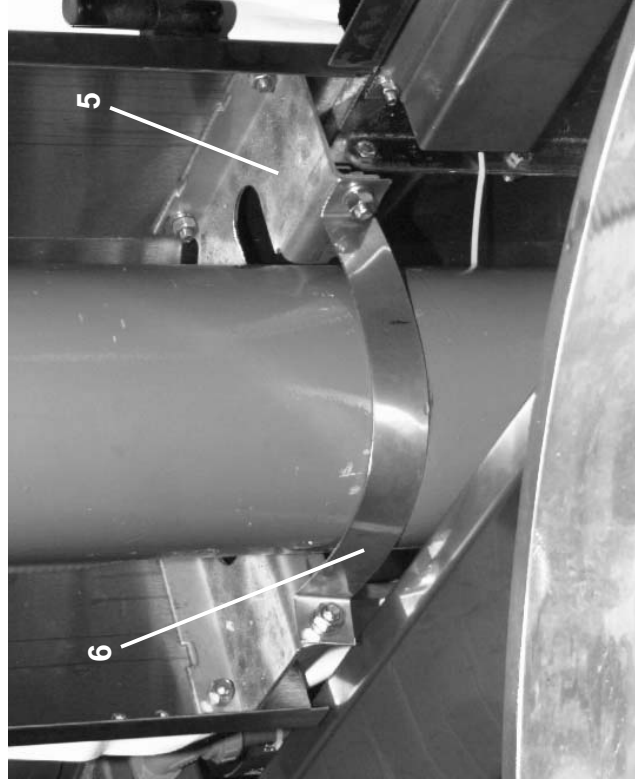

Typical cosmetic to frame connections

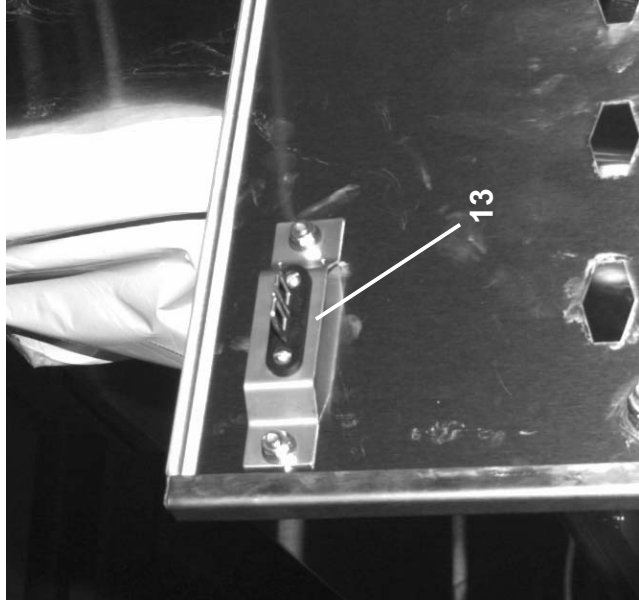

Typical door striker mounting



16



Safety stand storage bracket
(Safety stands, See BMP110003)

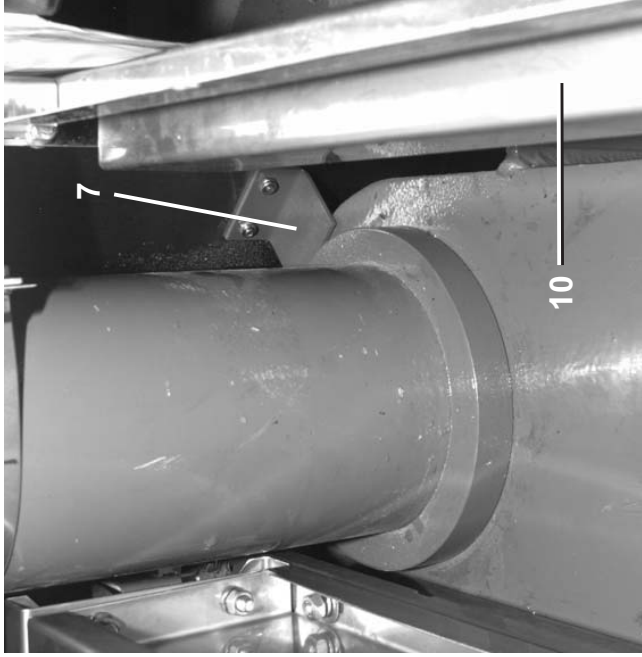
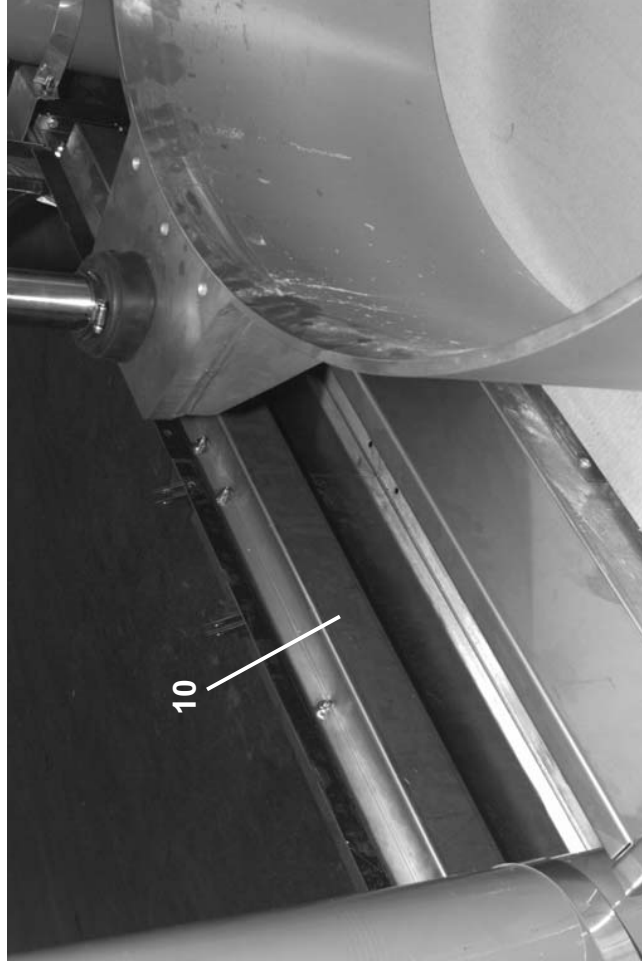



Pellerin Milnor Corporation
P. O. Box 400, Kenner, LA 70063-0400

Litho in U.S.A.

Parts List—Guards, Covers & Cosmetics

Find the correct assembly first, then find the needed components. The item letters (A, B, C, etc.) assigned to assemblies are referred to in the "Used In" column to identify which components belong to an assembly. The item numbers (1, 2, 3, etc.) assigned to components relate the parts list to the illustration.

Used In	Item	Part Number	Description	Comments
			-----ASSEMBLIES-----	
	A	ACS10015	COSMETIC ASSY-MP1A50	
			-----COMPONENTS-----	
all	1	07 10291	COSMATIC CORNER-MP1A03 SSPRESS	
all	2	07 10294	COSM TOP DOOR FRAME-MP1A03	
all	3	07 10292	CONV LOADEND FRAME-MP1A03	
all	4	07 10297	LOADCHUTE TOP FRAME-MP1A03	
all	5	07 10205	COSM CORNER ATTACH BRKT	
all	6	07 10206	COSMETIC CORNER STRAP	
all	7	07 10200B	COSMETIC CORNER SUPPORT BRKT	
all	9	07 10299	DOOR SIDE FRAME-MP1A03	
all	10	07 10378	DOOR PANEL-MP1A03	
all	11	07 10255A	PLATE=SSPRESSSS FLT REC SWPNL	
all	12	07 10379	DOOR W/ CTRL PANEL-MP1A03	
all	13	07 10363	DOOR STRIKER MTG BRKT	
all	14	07 10204	SAFETY STAND HANGER-SSPRESS	
all	15	07 10018	LOADCHUTE GUARD 7632	
All	16	07 10294A	COSM TOP DOOR FRAME W/NOTCH	

Can Safety Stands and Diaphragm Bar

MP1540xx, MP1556xx, MP1640xx, MP1650xx, MP1656xx, MP1A50xx
MPL556xx, MPL640xx, MPL650xx, MPL656xx

⚠ DANGER ⚠



CRUSH HAZARD - Descending can and/or platen will crush anyone under it. Can and/or platen can descend even with power off.

NEVER crawl or reach under the can and/or platen.

Lock OFF and tag out power and secure factory-supplied safety supports in place before crawling or reaching under the can and/or platen to perform service or maintenance.

ALWAYS ensure all personnel are clear of the press and receiving conveyor before returning power to either machine for service or maintenance.

Figure 1: Can Safety Stand Installation

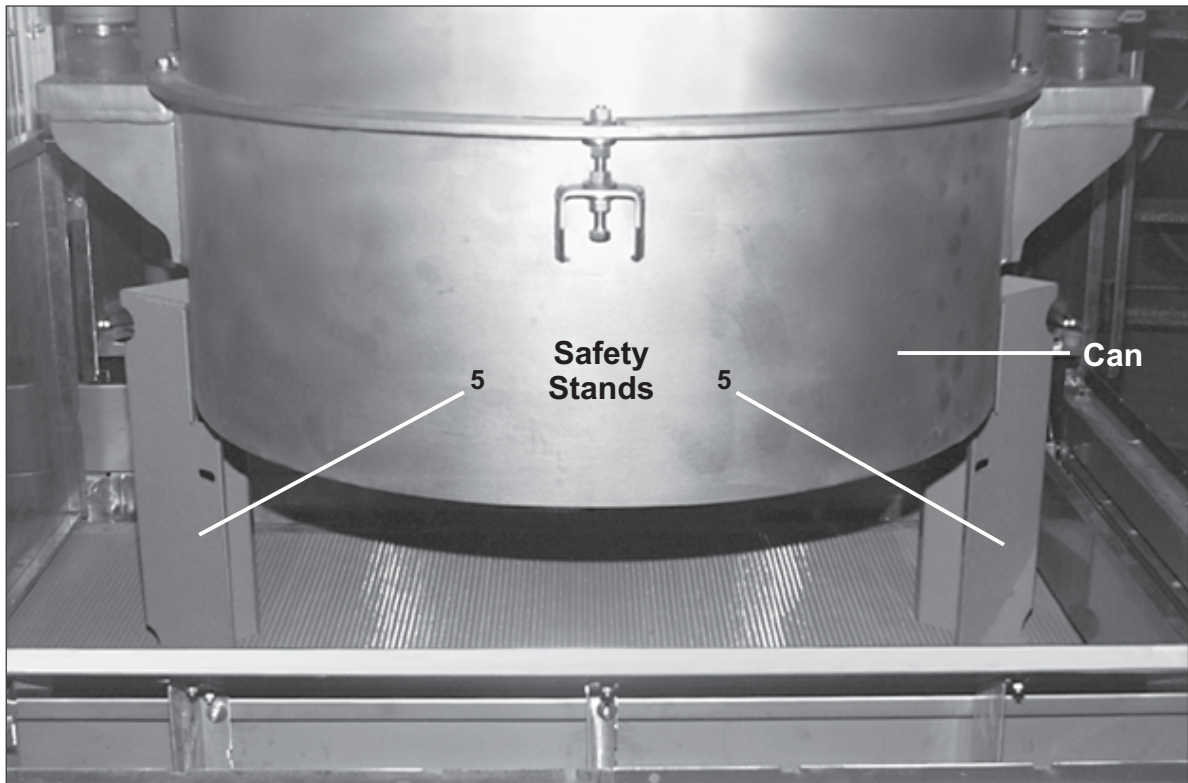

(Always install Safety Stands and Diaphragm Safety Bar before servicing. See BIUUUS27.)

Can Safety Stands and Diaphragm Bar

MP1540xx, MP1556xx, MP1640xx, MP1650xx, MP1656xx, MP1A50xx
MPL556xx, MPL640xx, MPL650xx, MPL656xx

Figure 2: Safety stand storage

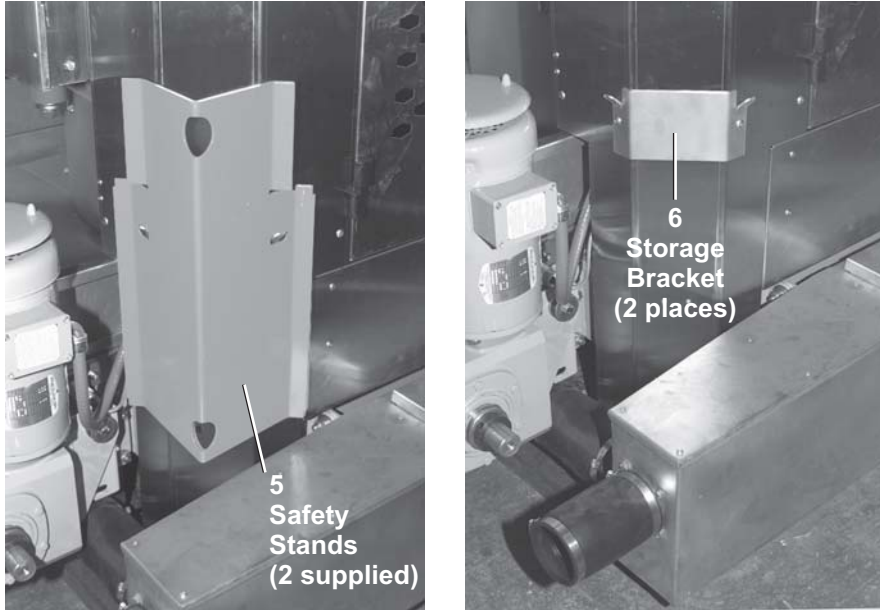
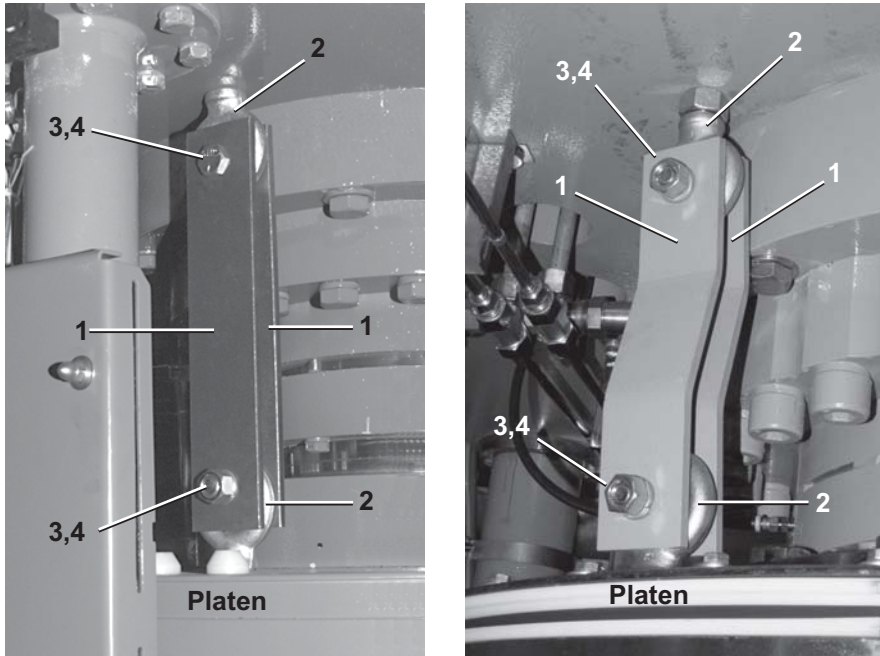

Figure 3: Diaphragm Safety Bar Installed



(All models except MP1A_)

(MP1A_ only)

Figure 4: Platen plugs

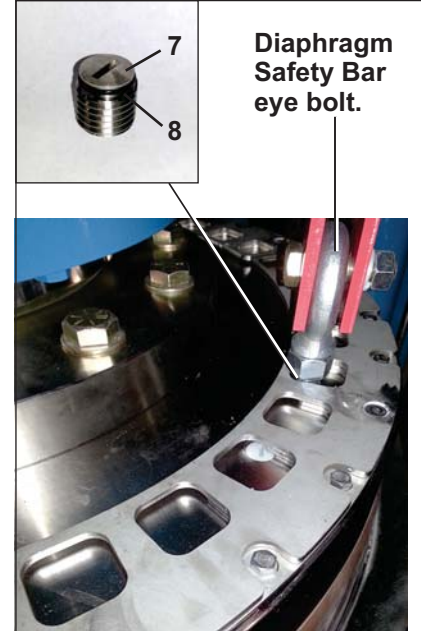

When the Diaphragm Safety Bar eye bolt is removed, plug the threaded hole with the steel plug and o-ring (items 7 & 8).

Can Safety Stands and Diaphragm Bar

MP1540xx, MP1556xx, MP1640xx, MP1650xx, MP1656xx, MP1A50xx
 MPL556xx, MPL640xx, MPL650xx, MPL656xx

Parts List—Can Safety Stands and Diaphragm Bar				
Find the correct assembly first, then find the needed components. The item letters (A, B, C, etc.) assigned to assemblies are referred to in the "Used In" column to identify which components belong to an assembly. The item numbers (1, 2, 3, etc.) assigned to components relate the parts list to the illustration.				
Used In	Item	Part Number	Description	Comments
-----ASSEMBLIES-----				
	A	AHT10031A	SHIP WITH MACHINE-SSPRESS	MP1540 MP1556, MP1640 MPL556, MPL640
	B	AHT10031	SHIP WITH MACHINE-MP1656	MP1650, MP1656 MPL650, MPL656
	C	AHT10036	SHIP WITH MACHINE-MP1A03	MP1A50
	D	AHT10030	MEMBRANE SAFETY BAR-MP1603	MP1540 MP1556, MP1640 MPL556, MPL640
	E	AHT10030A	MEMBRANE SAFETY BAR-MP1604	MP1650, MP1656 MPL650, MPL656
	F	AHT10030B	DIAPHM SAFETY BAR ASSY-MP1A03	MP1A50
-----COMPONENTS-----				
D	1	07 10262	DIAPHRAM SAFETY BAR	
E	1	07 10262B	DIAPHRAM SAFETY BAR-16"LG	
F	1	07 10282	MEMBRANE SAFETY BAR-47BAR	
all	2	17A054	EYEBOLT 1-8 UNC ZINC PLATED	
all	3	15K235AB	HXCAPSCR 3/4-10UNC2AX3"GR8 ZIN	
all	4	15G240	HXNUT 3/4-10UNC2B SAE ZINC GR2	
AB	5	07 30093	SAFETY SUPPORT-BELL TF60	
C	5	07 10385	SAFETY STAND-48"CAN MP1A03	
all	6	07 10204	SAFETY STAND HANGER-SSPRESS	
All	7	X7 10059	PLUG-PLATEN LIFTING EYE BOLT	
All	8	60C112	ORING 5/8IDX3/32CS BUNA70 #114	

Ship With

MP1540xx, MP1556xx, MP1640xx, MP1650xx, MP1656xx, MP1A50xx
MPL556xx, MPL640xx, MPL650xx, MPL656xx

BMP110004/2020275B
(1/2)



Pellerin Milnor Corporation
P. O. Box 400, Kenner, LA 70063-0400

Litho in U.S.A.

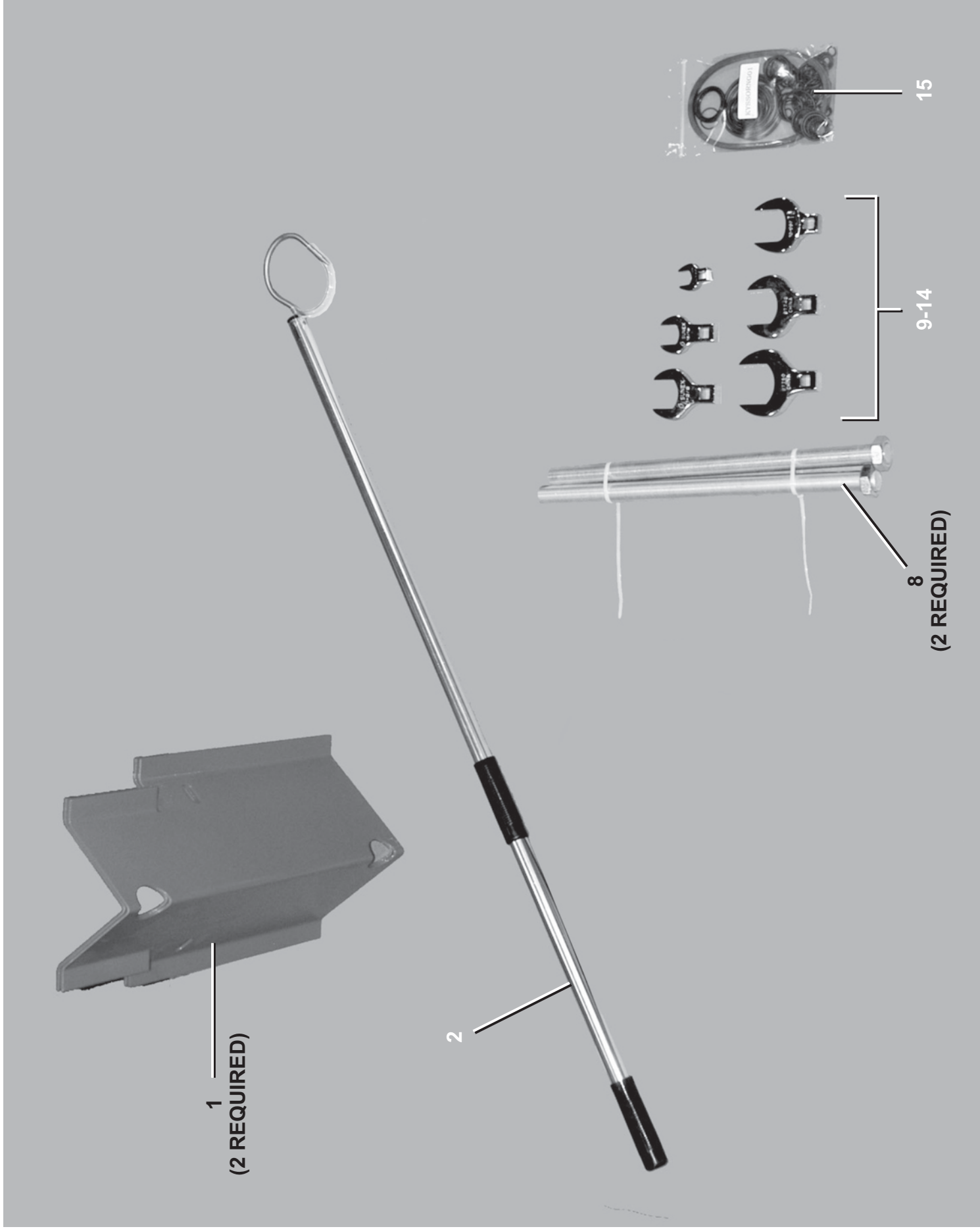

Plugs:
Items 16-23,30
(not shown)
See parts list.



25

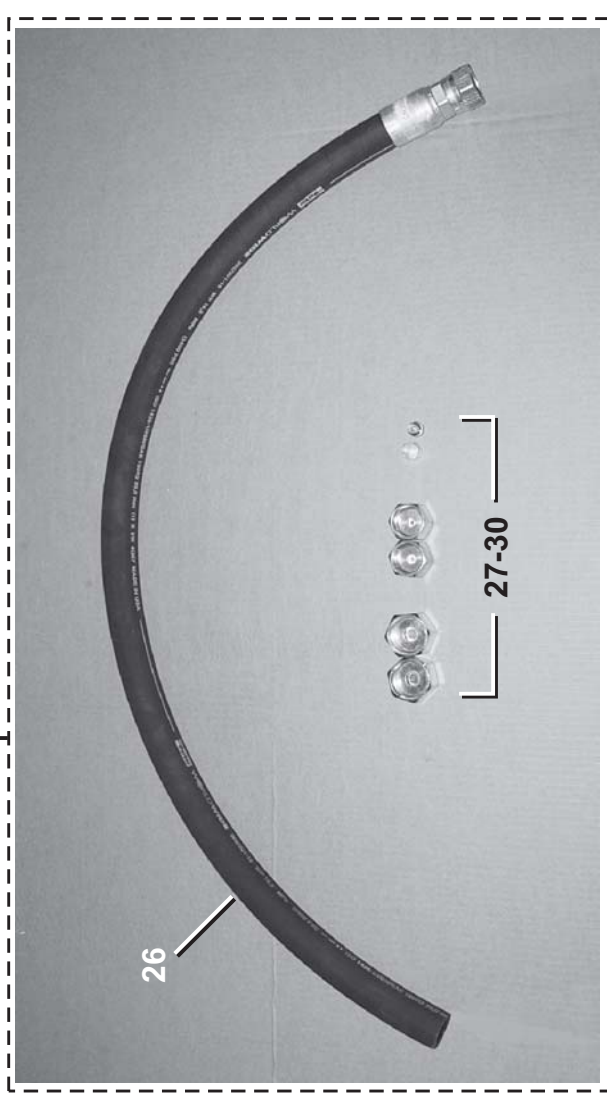

Ship With

MP1540xx, MP1556xx, MP1640xx, MP1650xx, MP1656xx, MP1A50xx
 MPL556xx, MPL640xx, MPL650xx, MPL656xx

BMP110004/2020275B
 (2 / 2)



Pellerin Milnor Corporation
 P. O. Box 400, Kenner, LA 70063-0400

Litho in U.S.A.

Used In	Item	Part Number	Description	Comments
			ASSEMBLIES-----	
A	AHT10031A		SHIP WITH MACHINE-MP1540,1556,1640	MP1540 MP1550, Mp1640 MPL550, MPL640
B	AHT10031		SHIP WITH MACHINE-MP1656	MP1656, Mp1650 MPL656, MPL650
C	AHT10036		SHIP WITH MACHINE-MP1A50	MP1A50
			COMPONENTS-----	
all	1	07 30093	SAFETY SUPPORT-BELL TF60	
all	1	07 10385	SAFETY STAND-48"CAN MP1A03	
all	2	27A900	ALUM. GAFF 5/16"DIAX48"L W/3"	
all	8	17R036A18A	THRD ROD 1-14X18" ZINC	
all	9	97G006C	11/16" X 3/8" DR CROWSFOOT	
all	10	97G010C	15/16" X 1/2" DR CROWSFOOT	
all	11	97G014C	1+3/8" X 1/2" DR CROWSFOOT	
all	12	97G021A	1+1/2" X 1/2" DR CROWSFOOT	
all	13	97G022C	1+5/8" X 1/2" DR CROWSFOOT	
all	14	97G023C	1+7/8" X 1/2" DR CROWSFOOT	
all	15	KYSSORNG01	SS PRESS HYD ORING ASST KIT	
all	16	51P081	PLUG TAPERED 5.7"CAPLUG#T1092	
all	17	51P082	PLUGCAPNOTHD 1.437"CAPLUG#EC23	
all	18	51P083	PLUGCAPNOTHD 1.187"CAPLUG#EC19	
all	19	51P084	PLUGTHD.3/4"O.R.CAPLUG#PDF-120	
all	20	51P085	PLUGTHD.1/4"JIC CAPLUG#PD40	
all	21	51P086	PLUGTHD.1"O.R.CAPLUG#PDF160	
all	22	51P087	PLUGTHD.1"JIC CAPLUG#PD-160	
all	23	51P088	PLUGCAPSLV 13/16 #SC-13/16	
all	25	AHT10037	TROUBLE SHOOTING KIT-SSPRESS	
all	26	60EH80C48B	ASSY=HYDHOSE+ONE END 1"X48"LG	(PART OF ITEM 25)
all	27	52ZN1AS003	TUBEFIT NUT+CAP #16-FNL-S	(PART OF ITEM 25)
all	28	52ZN0PS003	TUBEFIT NUT+CAP 3/4" 12 FNL-S	(PART OF ITEM 25)

Parts List, cont.— Ship With				
Used In	Item	Part Number	Description	Comments
A	31	AHT10038	RAM INSTL BOLTS/LUBE-MP1603	
BC	31	AHT10039	RAM INSTL BOLTS/LUBE-MP1604	
A	32	X7 10504	RAM BOLT 1-14X5"CHASED THREAD	(PART OF ITEM 31)
BC	32	X7 10505	RAM BOLT 1-14X7"CHASED THREAD	(PART OF ITEM 31)
all	33	15U393	FLTWASH 1" HARD ASTM F436	(PART OF ITEM 31)
all	34	20C510	LOCTITE MOLYPASTE#51048	(PART OF ITEM 31)

Safety Unload Door

MP1540, MP1556, MP1640, MP1650, MP1656, MP1A50
 MPL556, MPL640, MPL650, MPL656

BMP110005/2020275A
 (1 / 3)



Pellerin Milnor Corporation
 P. O. Box 400, Kenner, LA 70063-0400

Litho in U.S.A.

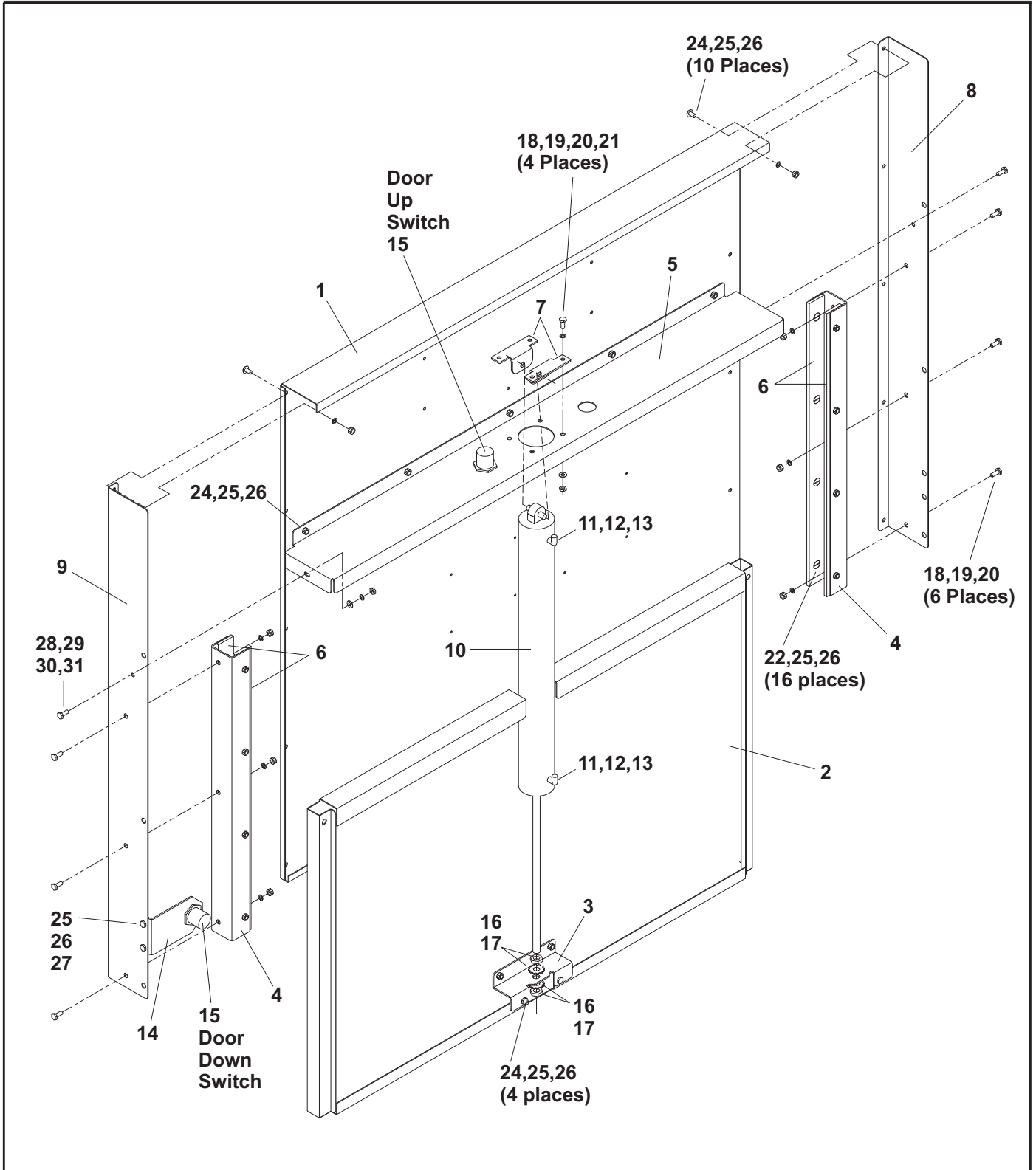

Safety Unload Door

**MP1540, MP1556, MP1640, MP1650, MP1656, MP1A50
MPL556, MPL640, MPL650, MPL656**

BMP110005/2020275A
(2 / 3)



Pellerin Milnor Corporation
P. O. Box 400, Kenner, LA 70063-0400

Litho in U.S.A.

Parts List—Unload Door

Find the correct assembly first, then find the needed components. The item letters (A, B, C, etc.) assigned to assemblies are referred to in the "Used In" column to identify which components belong to an assembly. The item numbers (1, 2, 3, etc.) assigned to components relate the parts list to the illustration.

Used In	Item	Part Number	Description	Comments
-----ASSEMBLIES-----				
	A	ACS10001A	UNLOAD DOOR ASSY-SSPRESS	MP1540, MP1556, MPL556 MP1640, MP1650, MP1656 MPL640, MPL650, MPL656
	B	ACS10004A	CONV UNLOAD DOOR ASSY-MP1A56	MP1A50
-----COMPONENTS-----				
A	1	07 10633	CONV UNLOAD PANNEL	
B	1	07 10653	CONV UNLOAD PANNEL-MP1A56	
A	2	07 10632	CONV UNLOAD DOOR-SSPRESS	
B	2	07 10654	CONV UNLOAD DOOR	
A	3	07 10217	UNLOAD DOOR LIFTING BRKT	
B	3	07 10217A	DOOR LIFTING BRKT-MP1A56	
all	4	07 10218	DOOR TRACK-INSIDE	
A	5	07 10631	AIR CYL MTG CHANNEL	
B	5	07 10651	AIRCYL MTG CHANNEL-MP1A56	
all	6	07 10220	DOOR TRACK UHMW LINER	
all	7	07 10634	AIRCYL MTG BRKT-UNLOAD DOOR	
A	8	07 10630	UNLOAD DOOR MTG ANGLE-RT	
B	8	07 10652	UNLOAD DOOR MTG ANGLE-RT	
A	9	07 10630A	UNLOAD DOOR MTG ANGLE-LF	
B	9	07 10652A	UNLOAD DOOR MTG ANGLE-LF	
A	10	27C120	AIRCYL 1.5"BORE X 20"STROKE	
B	10	27C124	AIRCYL 1.5"BORE X 24"STROKE	
all	11	53A031B	BODY-EL90MALE.25X1/8 #269C-42B	
all	12	53A500	SLEEVE DELRIN 1/4"OD#60PT-4	
all	13	53A501	TUBE INSERT .163"OD #63PT-4-40	
all	14	07 10263	PROX.SW BKT-DISC DOOR DOWN	
all	15	09RPS30ADS	PROX SW QK CONN 30M NO-DC SHLD	
all	16	15G222A	HXFINJAMNUT 7/16-20UNF2B SS	
all	17	15U271	LOKWASH INTOOTH 7/16ZN	
all	18	15K052	HXCAPSCR 5/16-18UNC2AX3/4 SS18	
all	19	15U200S	FLATWASHER US STD 5/16 SS18-8	
all	20	15U205	LOCKWASHER MEDIUM 5/16" 18-8SS	
all	21	15G186	HEXNUT 5/16-18UNC2 SS18-8	

Safety Unload Door

**MP1540, MP1556, MP1640, MP1650, MP1656, MP1A50
MPL556, MPL640, MPL650, MPL656**

BMP110005/2020275A
(3 / 3)



Pellerin Milnor Corporation
P. O. Box 400, Kenner, LA 70063-0400

Litho in U.S.A.

Parts List, cont.

Find the correct assembly first, then find the needed components. The item letters (A, B, C, etc.) assigned to assemblies are referred to in the "Used In" column to identify which components belong to an assembly. The item numbers (1, 2, 3, etc.) assigned to components relate the parts list to the illustration.

Used In	Item	Part Number	Description	Comments
all	22	15N173	FLATMACSCR 1/4-20NCX5/8SS18-8	
all	23	15G164	HX THIN LOCKNUT NYL1/4-20 SS	
all	24	15K033	BUTSOKCAPSCR 1/4-20X5/8 SS18-8	
all	25	15U181	LOCKWASHER MEDIUM 1/4 SS18-8	
all	26	15G170	HEXNUT 1/4-20UNC2 SS18-8	
all	27	15N186	HXCAPSCR 1/4-20X3/4 SS18-8	
all	28	15K136	HEXCAPSCR 3/8-16UNCX3+1/2 GR5	
all	29	15U260	LOCKWASHER MEDIUM 3/8 SS18-8	
all	30	15G206	HEXNUT 3/8-16 UNC2 SS 18-8	
all	31	15U245	FLTWASH 3/8 STD COMM 18-8 SS	

Frame Assembly

MP1540xx, MP1556xx, MP1640xx, MP1650xx, MP1656xx, MP1656xx, MP1A50xx
MPL556xx, MPL640xx, MPL650xx, MPL656xx

BMP110006/2020275B
(1/2)



Pellerin Milnor Corporation
P. O. Box 400, Kenner, LA 70063-0400

Litho in U.S.A.

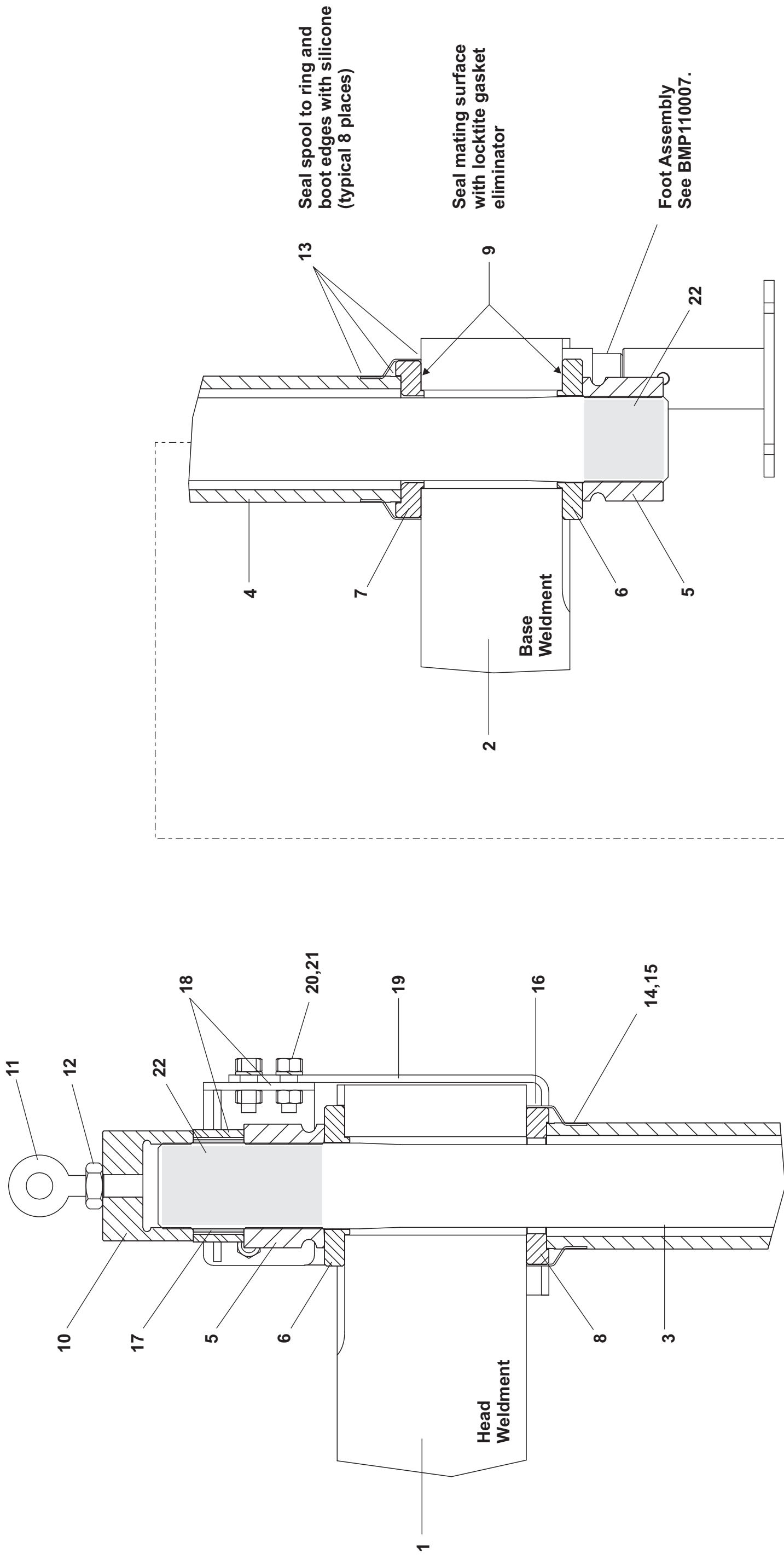

Frame Assembly

MP1540xx, MP1556xx, MP1640xx, MP1650xx, MP1656xx, MP1A50xx
MPL556xx, MPL640xx, MPL650xx, MPL656xx

BMP110006/2020275B
 (2 / 2)



Pellerin Milnor Corporation
 P. O. Box 400, Kenner, LA 70063-0400

Litho in U.S.A.

Used In	Item	Part Number	Description	Comments
			-----ASSEMBLIES-----	
A		GHG10005	SSPRESS FRAME ASSY-MP1603	MP1540
B		GHG10011	SSPRESS FRAME ASSY-MP1556	MP1556, MPL556
C		GHG10012	SSPRESS FRAME ASSY-MP1640	MP1640, MPL640
D		GHG10010	SSPRESS FRAME ASSY-MP1656	MP1656, MP1650
E		GHG10007A	SSPRESS FRAME ASSY-MP1A56	MPL656, MPL650
F		G80TD002	TIEROD HOLD DOWN INST-7.50 HEAD	MP1A50
G		G80TD001	TIEROD HOLD DOWN INST-9.50 HEAD	MP1556, MP1640
				MPL556, MPL640
				MP1656, MP1650
				MPL656, MPL650
				MP1A50
			-----COMPONENTS-----	
1		W7 10060	PRESS HEAD WELDMENT-35BAR	
1		W7 10076	PRESS HEAD WELDMENT-14"RAM	
1		W7 10641	PRESS HEAD WELDMENT-MP1640	
1		W7 10627	PRESS HEAD WELDMENT-MP1656	
1		W7 10120	PRESS HEAD WELDMENT-MP1AXX	
2		W7 10008	PRESS BASE WELDMENT	
2		W7 10010	SSPRESS BASE WELDMENT-45BAR	
2		W7 10626	SSPRESS BASE WELDMENT-MP1656	
2		W7 10121	BASE WELDMENT-MP1AXX	
3		X7 10600A	TENSIONING ROD-MP1540/50/1603	
3		X7 10642	TENSIONING ROD-MP1556/1640	
3		X7 10625	TENSIONING ROD-16"RAM MP1656	
3		X7 10122	TENSIONING ROD-MP1AXX	
4		X7 10546	TIE ROD SPOOL-64.75LG	
4		X7 10536	TIE ROD SPOOL-66.25LG	
4		X7 10544A	TIE ROD SPOOL 80.00 LG	
5		X7 10584	ROD TENSIONING NUT-SSPRESS	
6		X7 10548	PRELOAD RING-TENSION ROD	
7		X7 10541	SPOOL RING-BASE 4.82 PILOT	
8		X7 10542	SPOOL RING-HEAD	
9		20C013B	GASKET ELIMINATOR LOC.#51580	
10		X7 10587	LIFTING EYE ADAPTER-SSPRESS	
11		17A054A	EYEBOLT W/SHOULDER 1.25-7X3 ST	
12		15G260	HXNIUT 1+1/4-7UNC2B BLK GR2	

Parts List, cont.—Frame Assembly				
Used In	Item	Part Number	Description	Comments
all	15	27A083S	HOSECLAMP 5+1/8-7"SSSSCR#HSS104	
all	16	27A089	HOSECLAMP S.S.SCREW 6+5/8-8.5	
all	17	12P061	MED-WALL SLEEVE 25' PER ROLL	
all	18	W7 10590	TIEROD HOLD DOWN WLMT	
F	19	07 10594A	TIEROD HOLD DOWN BRKT-MP1603	
G	19	07 10594	TIEROD HOLD DOWN BRKT	
H	19	07 10594B	TIEROD HOLD DOWN BRKT-11.50 HEAD	
all	20	15K232A	HEXCAPSCR 3/4-10X2 GR8 ZINC	
all	21	15U340	LOCKWASH MEDIUM 3/4 ZINCPL	
all	22	20C510	LOCTITE MOLYPASTE#51048	

Foot Assembly

MP1540xx, MP1556xx, MP1640xx, MP1650xx, MP1656xx, MP1656xx, MP1A50xx
 MPL556xx, MPL640xx, MPL650xx, MPL656xx

BMP110007/2020275B
 (1/1)



Pellerin Milnor Corporation
 P. O. Box 400, Kenner, LA 70063-0400

Litho in U.S.A.

Used In		Item	Part Number	Description	Comments
<p>Parts List—Foot Assembly Find the correct assembly first, then find the needed components. The item letters (A, B, C, etc.) assigned to assemblies are referred to in the "Used In" column to identify which components belong to an assembly. The item numbers (1, 2, 3, etc.) assigned to components relate the parts list to the illustration.</p>					
all	1	X7 10585A		COMPONENTS	
all	2	X7 10563		PRESS SUPPORT ROD 1-1/2"-6UNC	
all	3A	W7 10606C		PRESS FOOT MTG NUT-MACHINED	3" FOOT
all	3B	W7 10606		SSPRESS FOOT WELDMENT-3.0"	4.5" FOOT
all	3C	W7 10606B		SSPRESS FOOT WELDMENT-4.5"	5.5" FOOT
all	3D	W7 10606A		SSPRESS FOOT WELDMENT-5.5"	7.5" FOOT
all	3E	W7 10606D		SSPRESS FOOT WELDMENT-11.5"	11.5" FOOT
All	4	15K210A		HXCAPSCR 1/2"-13X4" GRD 8 ZINC	
All	5	15G234N		HXLOCKNUT NYL 1/2-13UNC2 STL/Z	

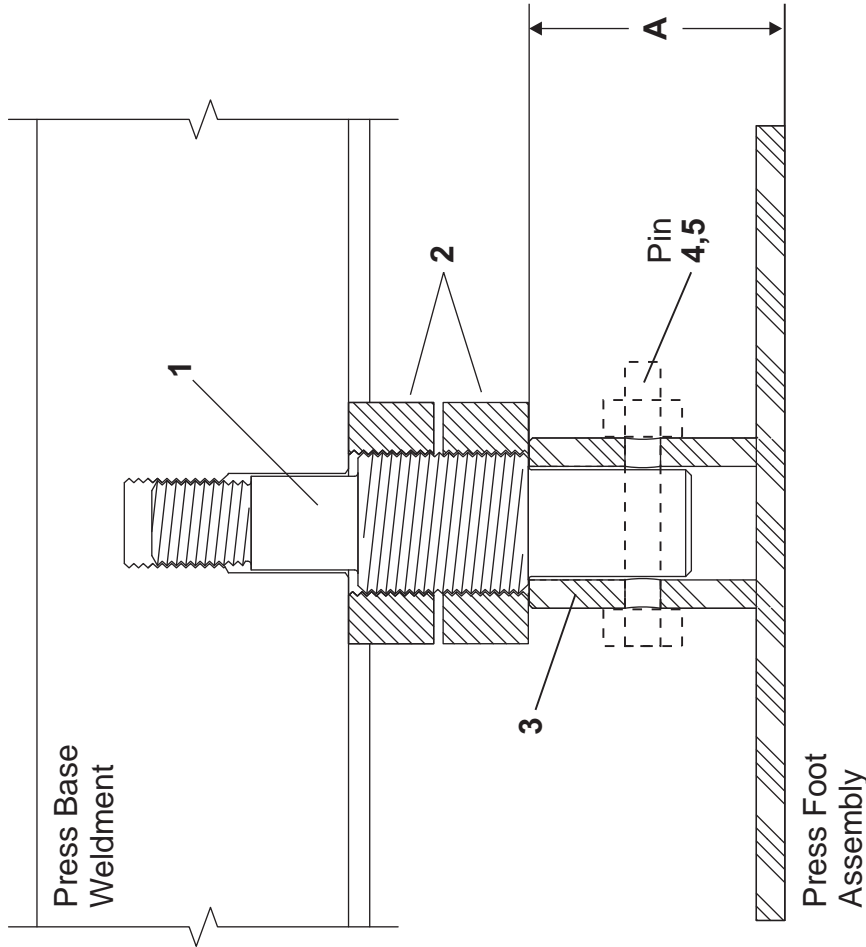

Foot	A
W7 10606C	3.0"
W7 10606	4.5"
W7 10606B	5.5"
W7 10606A	7.5"
W7 10606D	11.5"

Reuse Tank

MP1540xx, MP1556xx, MP1640xx, MP1650xx, MP1656xx, MP1A50xx
 MPL556xx, MPL640xx, MPL650xx, MPL656xx

BMP110008/2020275B
 (1/2)



Pellerin Milnor Corporation
 P. O. Box 400, Kenner, LA 70063-0400

Litho in U.S.A.

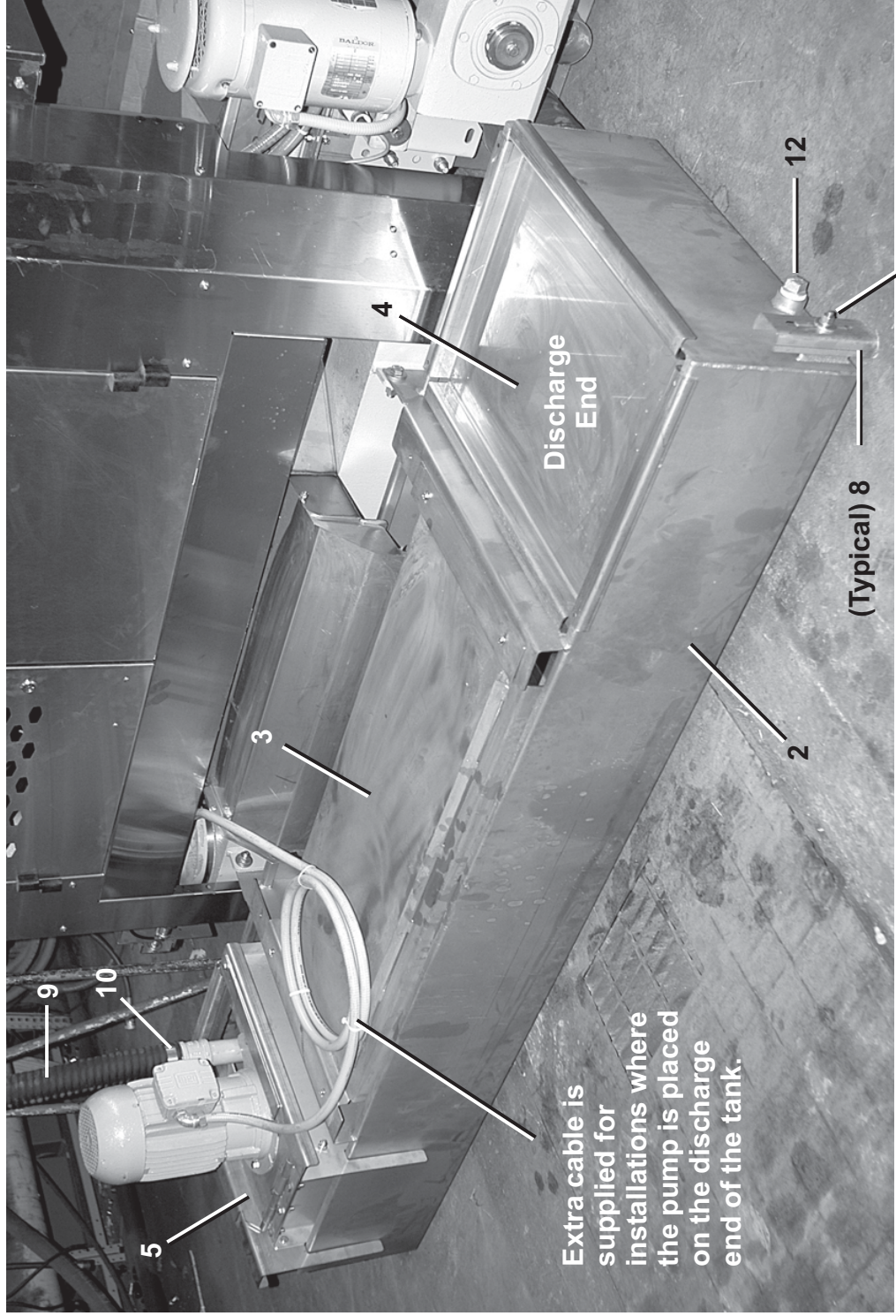

Extra cable is supplied for installations where the pump is placed on the discharge end of the tank.

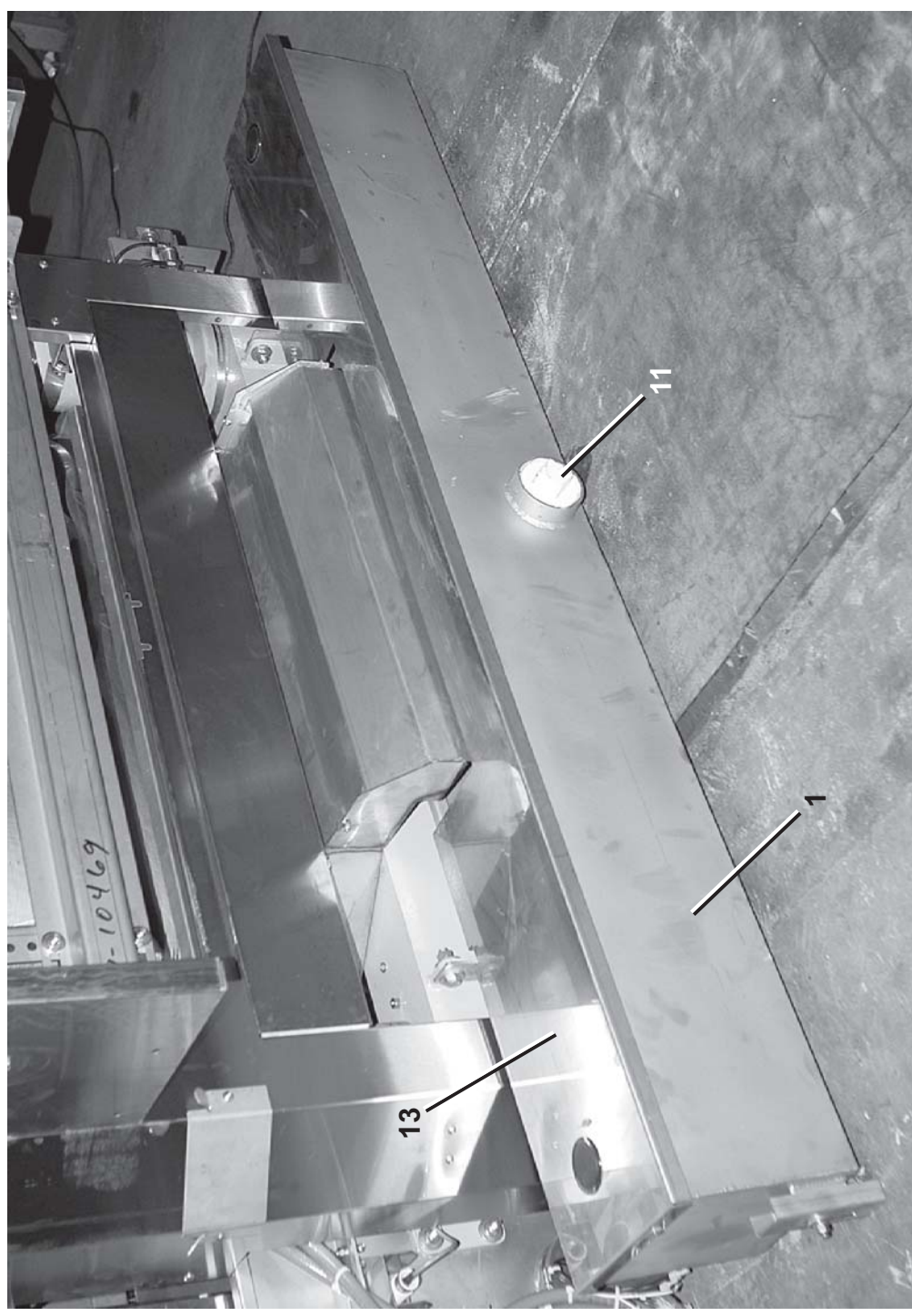
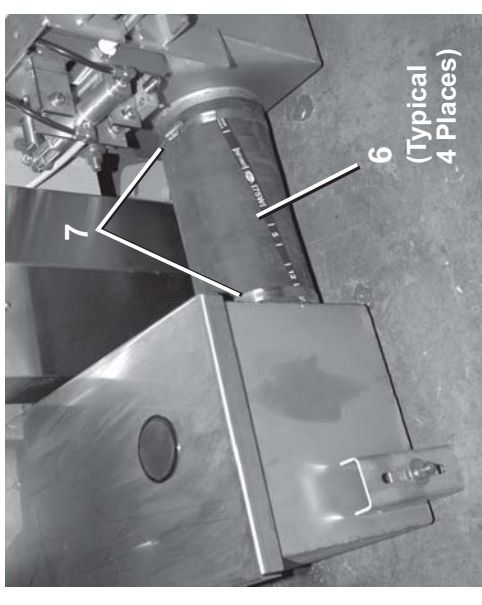
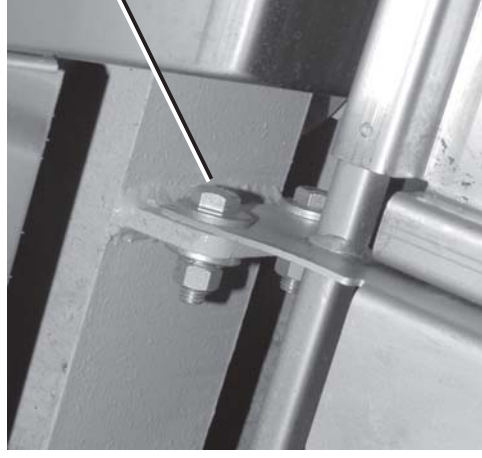

MP1540, MP1556, MP1640, MP1650, MP1656 reuse tanks are shown. MP1A50 reuse tank is similar. See parts list.

Reuse Tank

MP1540xx, MP1556xx, MP1640xx, MP1650xx, MP1656xx, MP1A50xx, MPL556xx, MPL640xx, MPL650xx, MPL656xx

**BMP110008/2020275B
(2 / 2)**



Pellerin Milnor Corporation
P. O. Box 400, Kenner, LA 70063-0400

Litho in U.S.A.

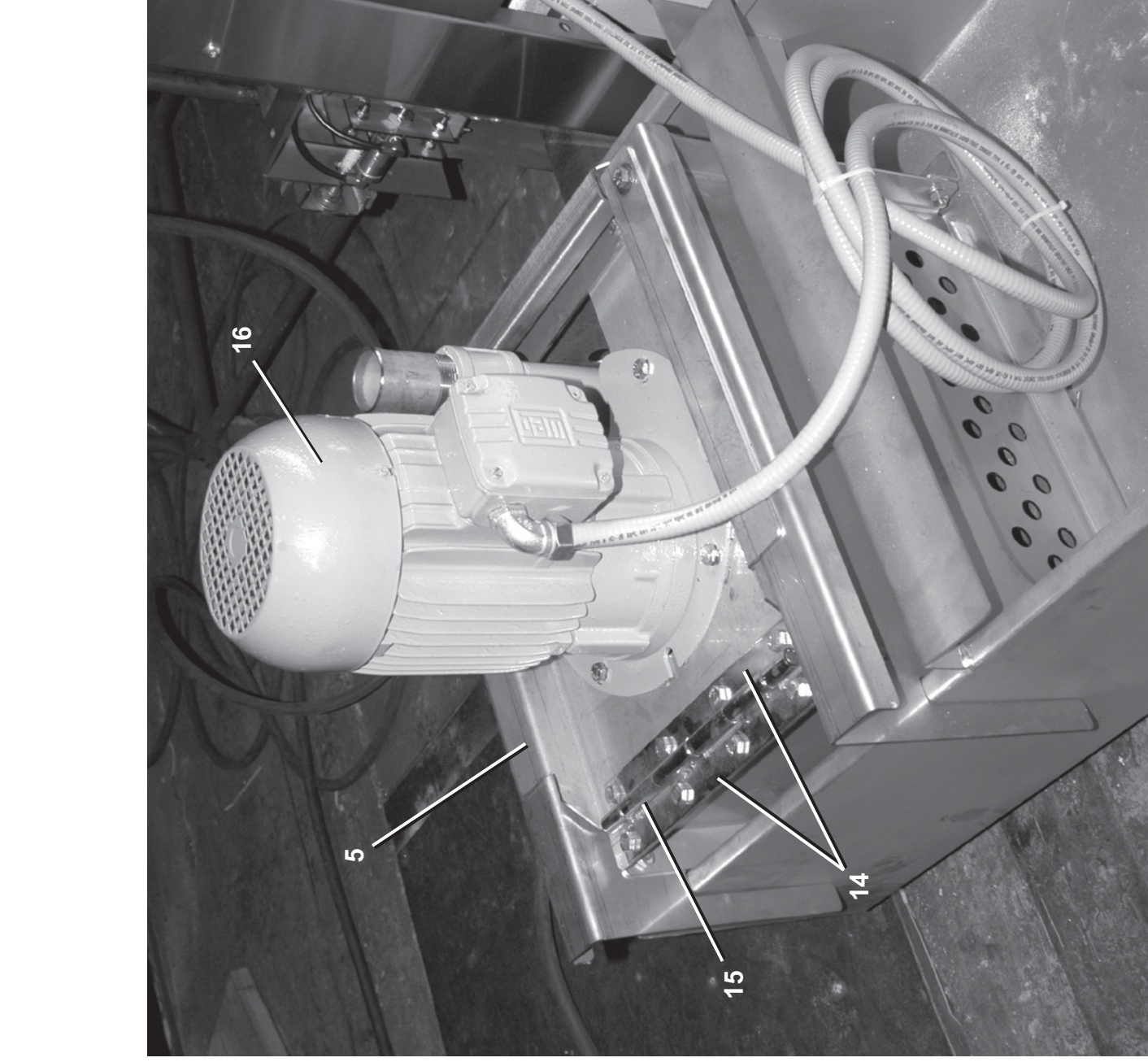

Parts List—Reuse Tanks
Find the correct assembly first, then find the needed components. The item letters (A, B, C, etc.) assigned to assemblies are referred to in the "Used In" column to identify which components belong to an assembly. The item numbers (1, 2, 3, etc.) assigned to components relate the parts list to the illustration.

Used In	Item	Part Number	Description	Comments
			-----ASSEMBLIES-----	
A		ALC420175	SIDE TANK+PUMP LAYT-MP1603	MP1540, MP1556
B		ALC420172	SIDE TANK+PUMP LAYT-MP1A03	MP1640, MP1656, MP1650 MP1A50
			-----COMPONENTS-----	
A	1	W4 23593	SIDE TANK NARROW	
B	1	W4 23638	MP1A03 SIDE TANK NARROW	
A	2	W4 23594	SIDE TANK WIDE WLDMNT	
B	2	W4 23640	MP1A03 SIDE TANK WIDE WLDMNT	
A	3	W4 23548	SIDE TANK COVER WLDMT	
B	3	W4 23643	MP1A03 SIDE TANK COVER WLDMT	
	4	07 10495	BLANK PUMP STAND COVER	
A	5	ALC420171	REUSE PUMP STAND ASSEMBLY	
B	5	ALC420219	REUSE PUMP STAND ASSEMBLY	
	6	60E312A11A	HOSE 5"ID X 11"LG GATES 75W	
	7	27A086	HOSECLAMP 3+1/8-6"CADSCR#HS-88	
	8	04 23474	CLEANOUT TANK LEG 4840M	
	9	60E201	HOSE 2"ID W/S GATES#4686-0200	
	10	27A072	T-BOLT HOSECLAMP2.16-2.47CADSC	
	11	5SP3AP4SC	NPT PLUG 3" SQ SK40 PVC	
	12	5SP1ADESC	NPT PLUG 1" SQ CORED GAL CI	
A	13	04 23629	SMALL SIDE TANK COVER	
B	13	04 23650	MP1A03 SMALL SIDE TANK COVER	
	14	W4 23539	WLMT=HINGE PRESS TANK	
	15	04 23540B	PIN=HINGEPUMP MOUNT	
	16	27E940A96	2X1-6.35PUMP W/3HP TEFC MOTOR	
	17	15K171	HEXCAPSCR 1/2-13UNC2X1+3/4 SS1	
	18	15U310S	FLATWASH-SS .53 X 1.37 .187T	
	19	15U310	LOKWASHER REGULAR 1/2 SS18-8	
	20	15G231S	HXFINJAMNUT 1/2-13UNC2B SS18-8	
	21	15A020S	CARBOLT 3/8-16X1" SS18-8	
	22	15U245	FLTWASH 3/8 STD COMM 18-8 SS	
	23	15U260	LOCKWASHER MEDIUM 3/8 SS18-8	
	24	15G206	HEXNUT 3/8-16 UNC2 SS 18-8	

Hydraulic Piping and Assemblies

2

Hydraulic Schematic

MP1556CL,CR,L,R *MP1640CL,CR,L,R MP1656CL,CR,L,R MP1A50CL,CR,L,R

BMP110021/2023153B
(1 / 2)



Pellerin Milnor Corporation
P. O. Box 400, Kenner, LA 70063-0400

Litho in U.S.A.

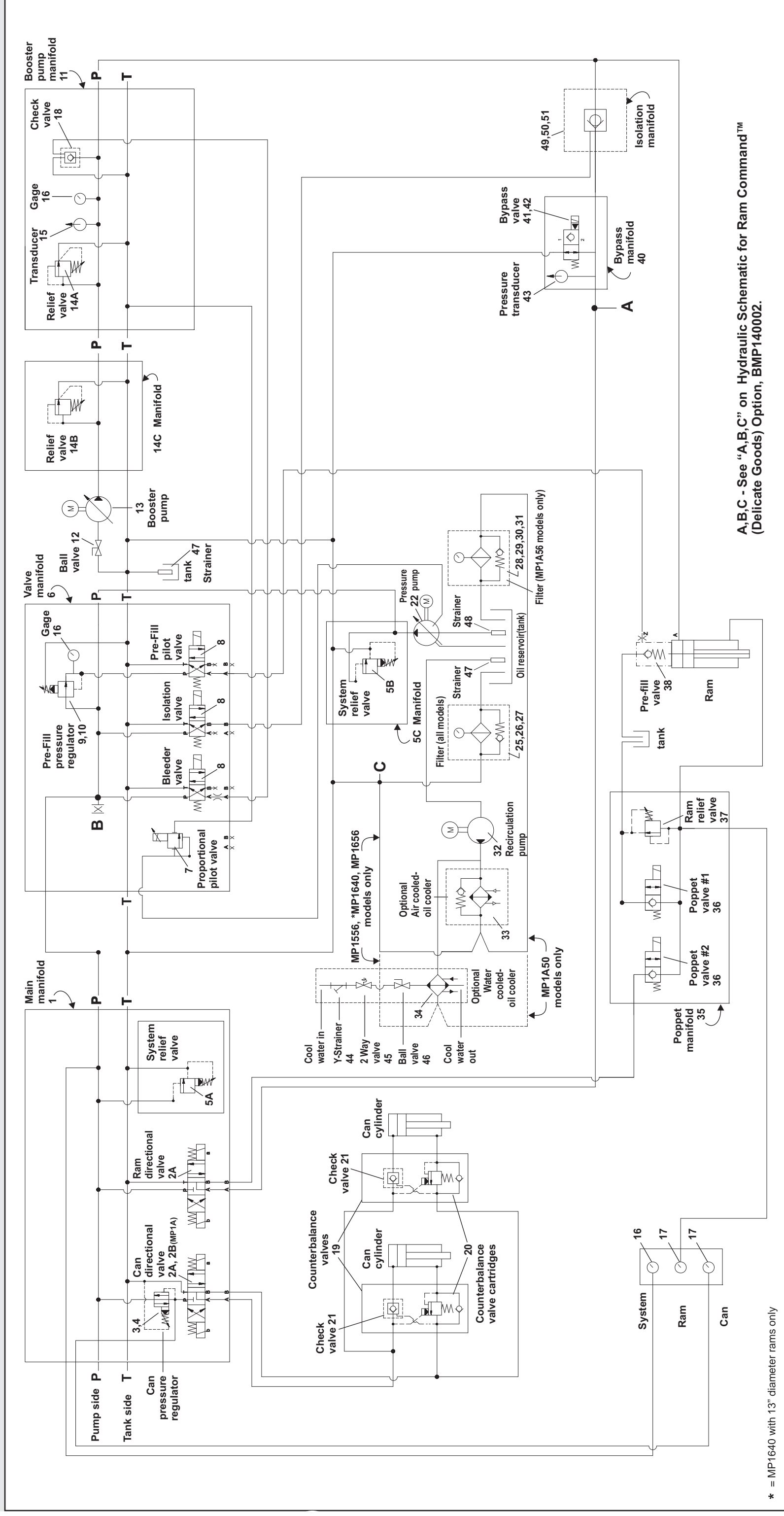

A,B,C - See "A,B,C" on Hydraulic Schematic for Ram Command™
(Delicate Goods) Option, BMP140002.

* = MP1640 with 13" diameter rams only



Pellerin Milnor Corporation
P. O. Box 400, Kenner, LA 70063-0400

BMP110021/2023153B
(2 / 2)

Litho in U.S.A.

Parts List—Hydraulic Schematic
Find the correct assembly first, then find the needed components. The item letters (A, B, C, etc.) assigned to assemblies are referred to in the "Used In" column to identify which components belong to an assembly. The item numbers (1, 2, 3, etc.) assigned to components relate the parts list to the illustration.

Parts List, cont.—Hydraulic Schematic

Used In		Item	Part Number	Description	Comments
				ASSEMBLIES-----	
		A	AHT10003	OIL RECIRC/COOLER-FITTINGS	
		B	AHT10003A	OIL RECIRC/COOLER-MP1A03	MP1556,*MP1640,MP1656
		C	AHT10010B	PREFILL VALVE MANIFOLD	MP1A50
		D	AHT10043	BOOSTER PUMP ASSEMBLY	
		DD	AHT10043A	BOOSTER PUMP ASSY-MP1AXX	MP1A50 ONLY
		E	AHT10045	WATER COOLED COOLER-SSPRESS	EFFECTIVE 9/2014
		F	AHT10002D	MAIN PRESS MANIFOLD-35/50BAR	MP1556,*MP1640,MP1656
		G	AHT10002E	MAIN PRESS MANIFOLD-MP1A03	MP1A50
				COMPONENTS-----	
		1	96DH453	MANIFOLD,DAMAN #DD05HP023S/S	MP1556,*MP1640,MP1656
all		1	96DH485	MANIFOLD-DAMAN DD08P025S/S	MP1A50 ONLY
all		2A	96RH709E37	DIRECT VALVE CENTER OP 24VDC	
all		2B	96RH720	DIRECT.CONT.VLV.ATOS (D08)	MP1A50 ONLY
all		3	96DH475A	CARTRIDGE,PRESS.REDUCING VALVE	
all		4	96DH475	PRESS.REDUCING VLV-SUN=BODY	
all		5A	96DH440A	CARTRIDGE,DIRECT RELIEF VALVE	
DD		5B	96DH440S	RELIEFVAL CARTRIDGE RDHA-LCN	EFFECTIVE 9/2014
DD		5C	96DH440U	MANIFOLD 90DEG SAE-20 SUN #IEN/S	EFFECTIVE 9/2014
all		6	96RH714	DAMAN MANIFOLD DD03P042SPA	
all		7	96RH708E38	PROP.RELIEF VALVE 6X DESIGN	
all		8	96RH712A02	DIRECTIONAL PILOT VALVE+SOLENOID	
all		9	96DH430B	BODY, SUN(STEEL) #EBP/S	
all		10	96DH430C	CARTRIDGE, SUN #PBDB-LAN	
all		11	96DH458A	MANIFOLD MODEL#SQ53692	
all		12	96D084	BALL VALVE BRZ 1" BONOMI 171N	
all		13	27E55049	PUMP DYNEX #PF1007-XV-10 HIGH PRES SEAL	EFFECTIVE 9/2014
all		14A	96DH450B	RELIEF VALVE STERLING #A02B2PZN	
DD		14B	96DH450D	RELIEF VALVE STERLING #A04B2PZN	EFFECTIVE 9/2014
DD		14C	96DH500	MANIFOLD, SELLING PRCISION B-12144	EFFECTIVE 9/2014
all		15	09N700D	TRANSDUCER WIKA C-10 0-10000 PSI	
all		16	30N127W	WIKAGAGE 7/16-20SAE 10000PSI/B	
all		17	30N125W	WIKA GAGE 7/16-20SAE 2000PSI/B	
all		18	96DH424	CKVAL CARTRIDGE STERLING#D5A040NMK2	
all		19	96DH471	COUNTERBALANCE VALVE-SUN BODY	
all		20	96DH471A	CARTRIDGE-COUNTERBAL.SUN	
all		21	96DH410	CART., SUN CHECKVALVE CKCB-XCN	
A		22	27E550566	PISTON PUMP-KAWASAKI(50BAR) K3VL 80/B	
B		22	27E550766	PISTON PUMP-KAWASAKI(110K)	
all		23	27E5512	HYD.NOISE SUPPRESSOR-WILKES	
all		24	27E5512A	KIT-NITROGEN CHG-WILKES#SV1KIT	
all		25	27E7106	IN-LINE RETURN FILTER	
all		26	27E7106A	FILTER ELEMENT-REPLACEMENT	
all		26	27E7106B	FILTER ELEMENT-STAUFF 25MIC	
all		27	30N101	PRESSGAUGE 1/8"BACKCN.0-60PSI	
all		28	27E7112	INTANK RETURN FILTER 1+1/4"	
all		29	27E7112B	FILTER ELEMENT-REPLACEMENT	
all		30	27E7112A	FILTER GAUGE-DONALDSON#P171956	
all		31	27E7112C	ELEC.INDICAT-DONALDSON#P171966	
all		32	27E5506	GEAR PUMP-RECIRC.PUMP-EATON	
all		33	27HS091AAU	OIL COOLER 8HP@15GPM 50/60	AS SPECIFIED
all		33	27HS092AAU	OIL COOLER 20HP@10GPM 50/60	AS SPECIFIED
all		33	27HS091A98	OIL COOLER 8HP@15GPM 575V	AS SPECIFIED
all		33	27HS092A98	OIL COOLER 20HP@10GPM 575V	AS SPECIFIED
all		34	27H11205	SSPRESS HEAT EXCHANGER THERMAL TRANSFER BPS-24-12X5	
all		35	96DH452	MANIFOLD, MACH-V	
all		36	96DH452A01	POPPET=COIL + CARTRIDGE	
all		37	96DH452A02	CARTRIDGE,RELIEF CARTRIDGE VLV	
all		38	96RH712F	PREFILL VALVE HAWE #F100-45	
all		40	96RH713	DAMAN MANIFOLD C-30448	
all		41	96RH713A01	SUN CARTRIDGE#L0DA-8DN	
all		42	96RH713A02	SUN CART&COIL#DAAAAMHN211	
all		43	09N700B	TRANSDUCER WIKA C-10 0-5000 PSI	
all		44	51T025	Y-STRAINER 1/2" CAST IRON	
all		45	96TDC2AA37	1/2"N/C2WY120V50/60C VLV(DRYVC)	
all		46	96D040F5HL	1/2" BALVAL S/S LL/HDL BONOMI	
all		47	27E7111	SUCT.STRAINER=EZYFLO#S-15-100	
all		48	27E7108	SUCTION STRAINER 2" PORT	
all		49	96DH423B	CKVAL BLOCK PARKER#830687	
all		50	96DH423	CKVAL CARTRIDGE STERLING #D06B2P1.0.0N	
all		51	96DH423A	CKVAL PILOT PISTON PARKER STERLING #717910N	

Hydraulic Hoses
MP1556, *MP1640, MP1656



Pellerin Milnor Corporation
 P. O. Box 400, Kenner, LA 70063-0400

BMP110036/2012055B
 (1 / 9)

Litho in U.S.A.

HOSES:

- H1) From Pre-fill Bypass to Filter on Tank, 3/4" x 60"
- H2) From Tank to Cooler Pump
1" x 32" (Left/Right Discharge)
1" x 44" (Center Discharge)
- H3) From Cooling Pump to Cooler:
Air Cooled / Water Cooled, 3/4" x 32"
- H4) From Cooler to top of Main Manifold, 3/4" x 84"
- H5) From Tank to Pressure Pump, 2" x 33"
- H6) Pressure Pump to Main Manifold, 1" x 36"
- H7) From Pressure Pump to Tank, 3/4" x 36"
- H8) From Booster Manifold to Isolation Manifold,
High Pressure, 3/4" x 54"
- H9) From Booster Pump to Booster Manifold,
High Pressure, 3/4" x 36"
- H10) From Main Pump to Proportional Pilot Valve, 1/4" x 40"
- H11) From bottom of Pre-fill Pilot to bottom of Main Manifold
1/4" x 42"
- H12) From Ram to Tank, 1/4" x 78"
- H13) Main System Pressure, 1/4" x 60"
- H14) Ram Relief, 1/4" x 60"
- H15) Can Relief, 1/4" x 60"
- H16) From Pre-fill Bypass Manifold to side of Main Manifold,
1" x 48"
- H17) Pre-fill Pipe to Tank, 4.5" x 12"
- H18) From Isolation Manifold to Pre-fill Valve, 1" x 84"
- H19) From Pre-fill Pilot to front of Main Manifold, 1/2" x 48"
- H20) From Pre-fill Pilot to Pre-fill Valve, 1/4" x 42"
- H21) From Booster Pump Manifold to bottom of
Bleeder Valve, 1/4" x 20"
- H22) From Isolation Manifold to Isolation Valve,
1/4" x 14"
- H23) From Proportional Pilot Valve to bottom of Booster
Manifold, 1/4" x 24"
- H24) From Tank to Booster Pump, 1" x 15"

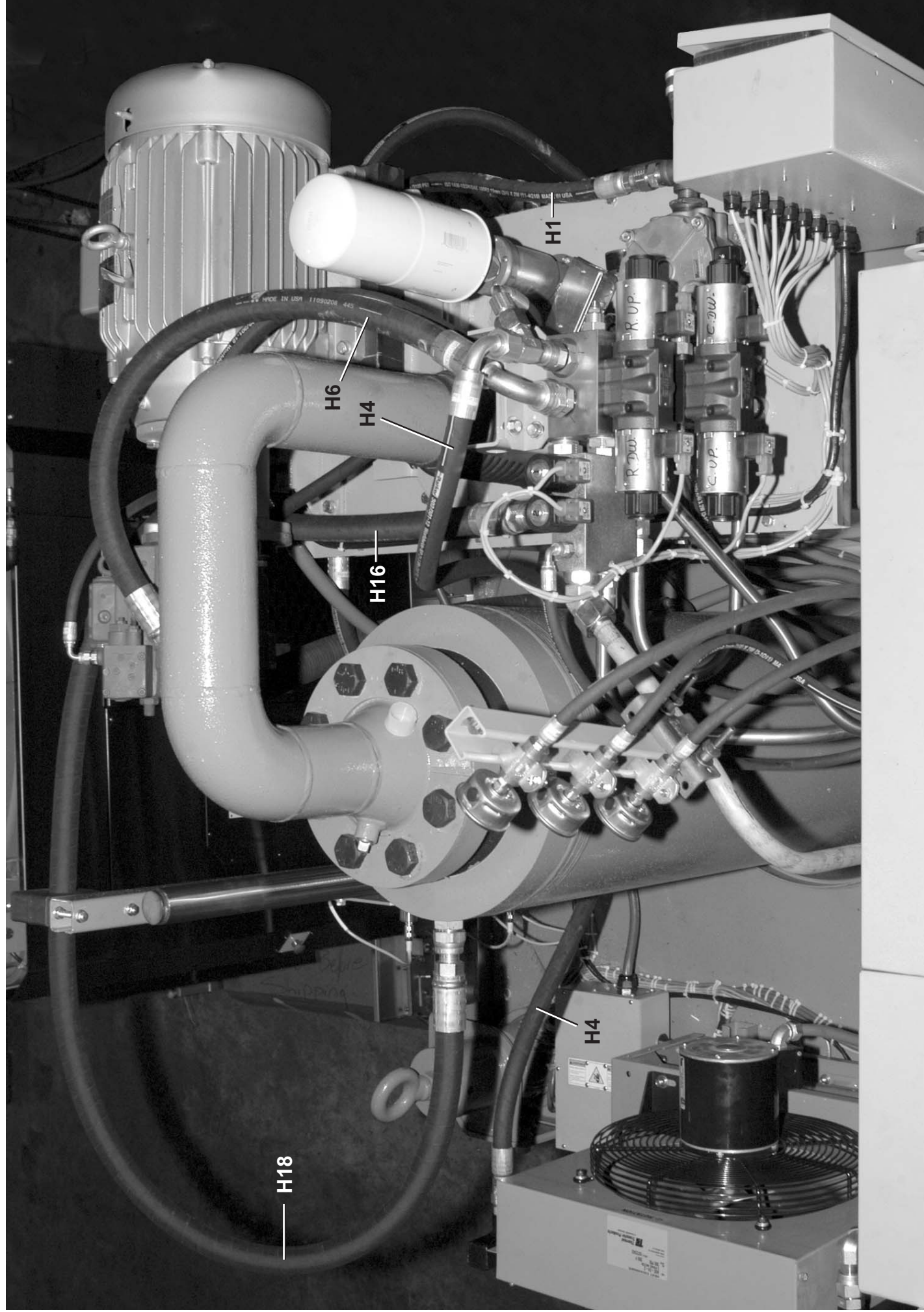

* = MP1640 with 13" ram

Hydraulic Hoses
MP1556, *MP1640, MP1656

BMP110036/2012055B
(3 / 9)



Pellerin Milnor Corporation
P. O. Box 400, Kenner, LA 70063-0400

Litho in U.S.A.

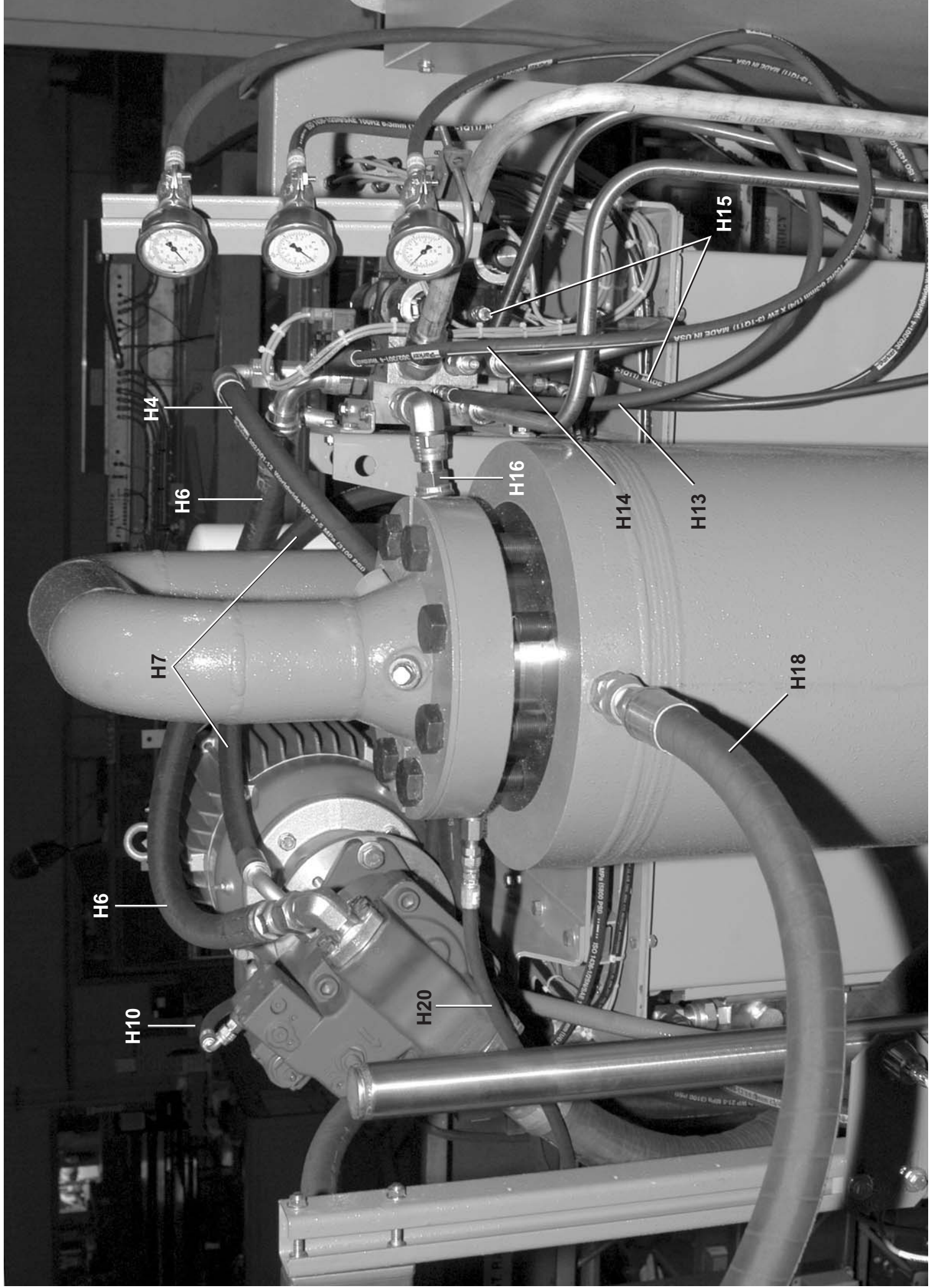

Hydraulic Hoses
MP1556, *MP1640, MP1656

BMP110036/2012055B
(4 / 9)



Pellerin Milnor Corporation
P. O. Box 400, Kenner, LA 70063-0400

Litho in U.S.A.

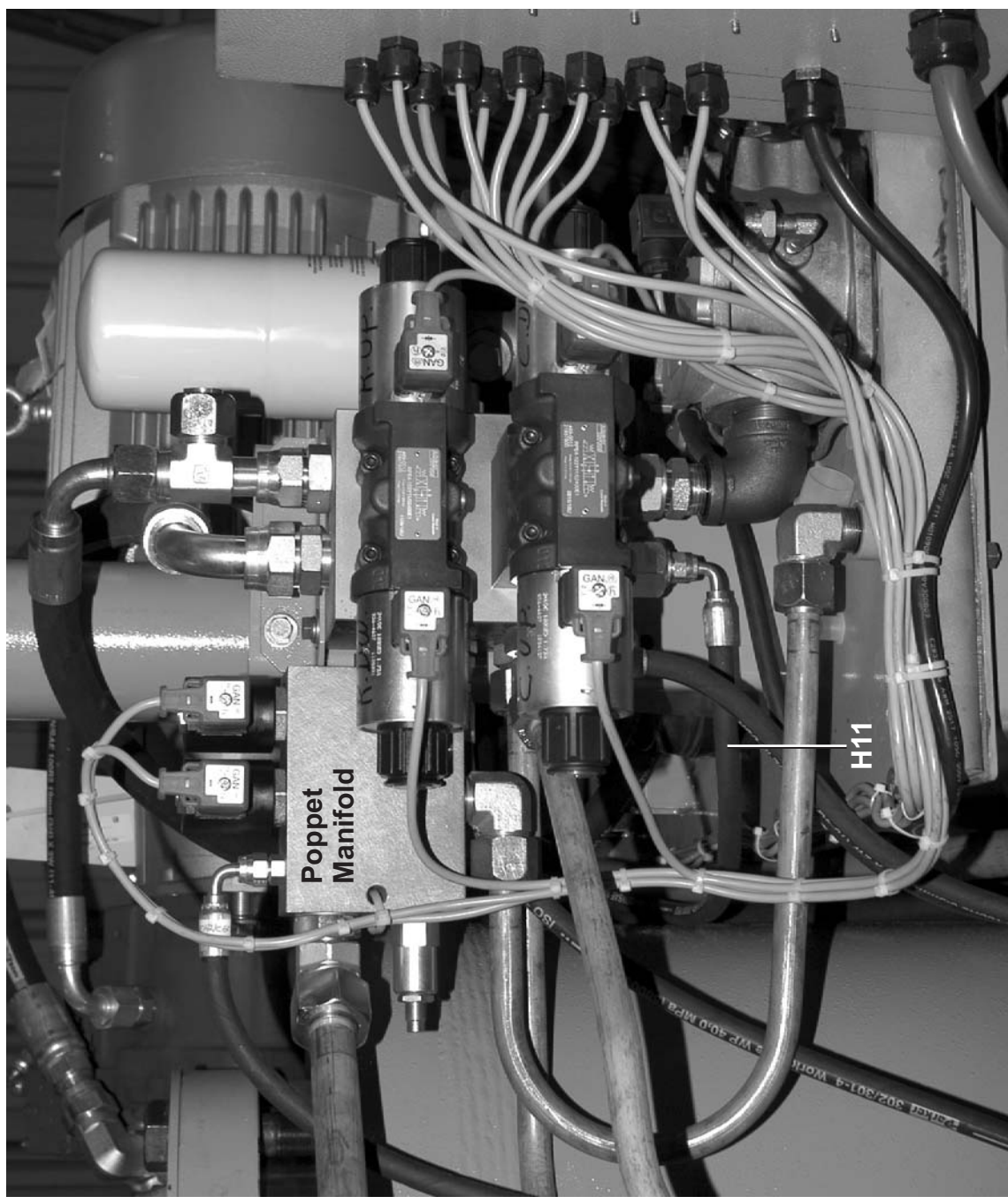
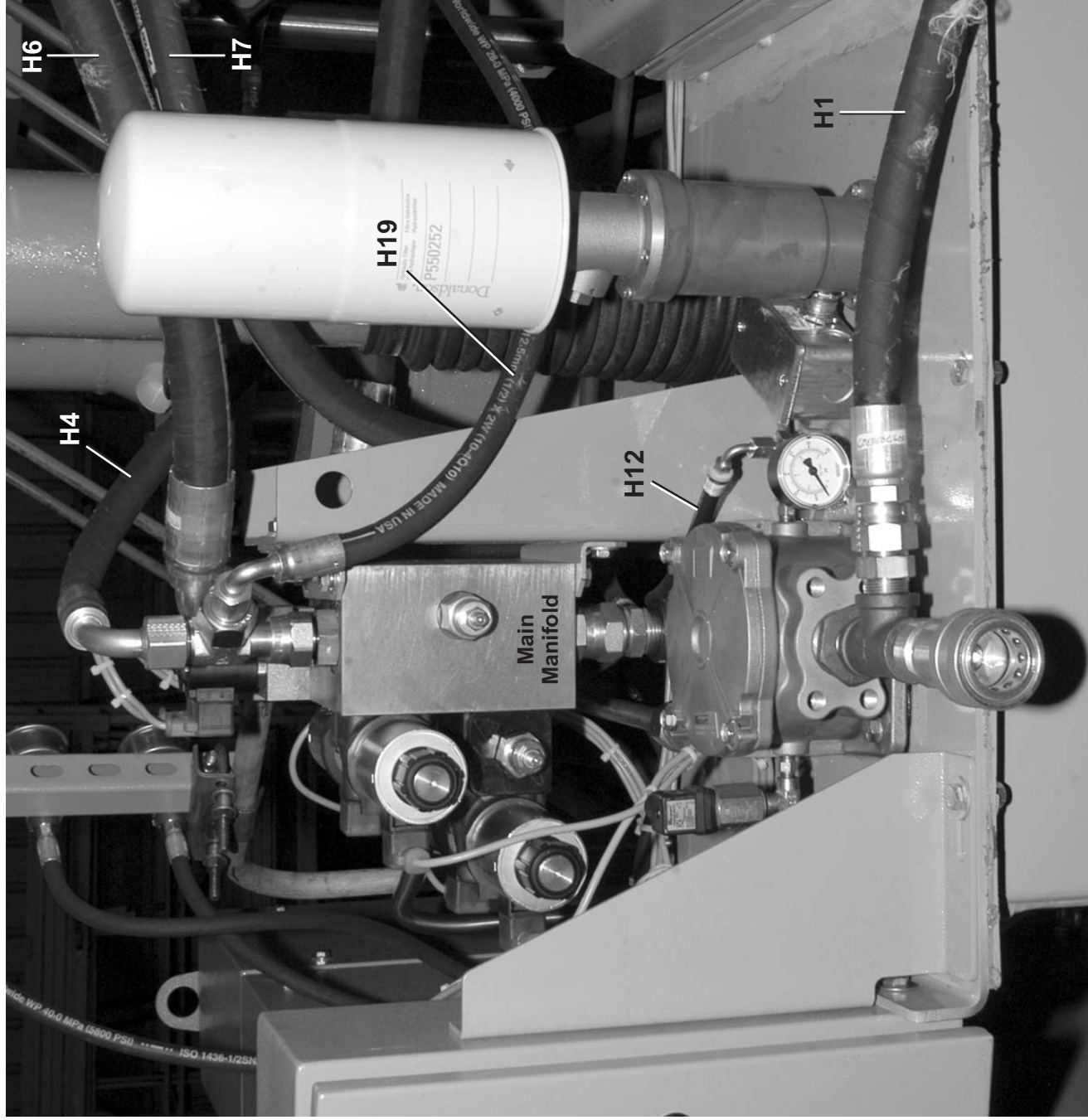



Pellerin Milnor Corporation
P. O. Box 400, Kenner, LA 70063-0400

Litho in U.S.A.

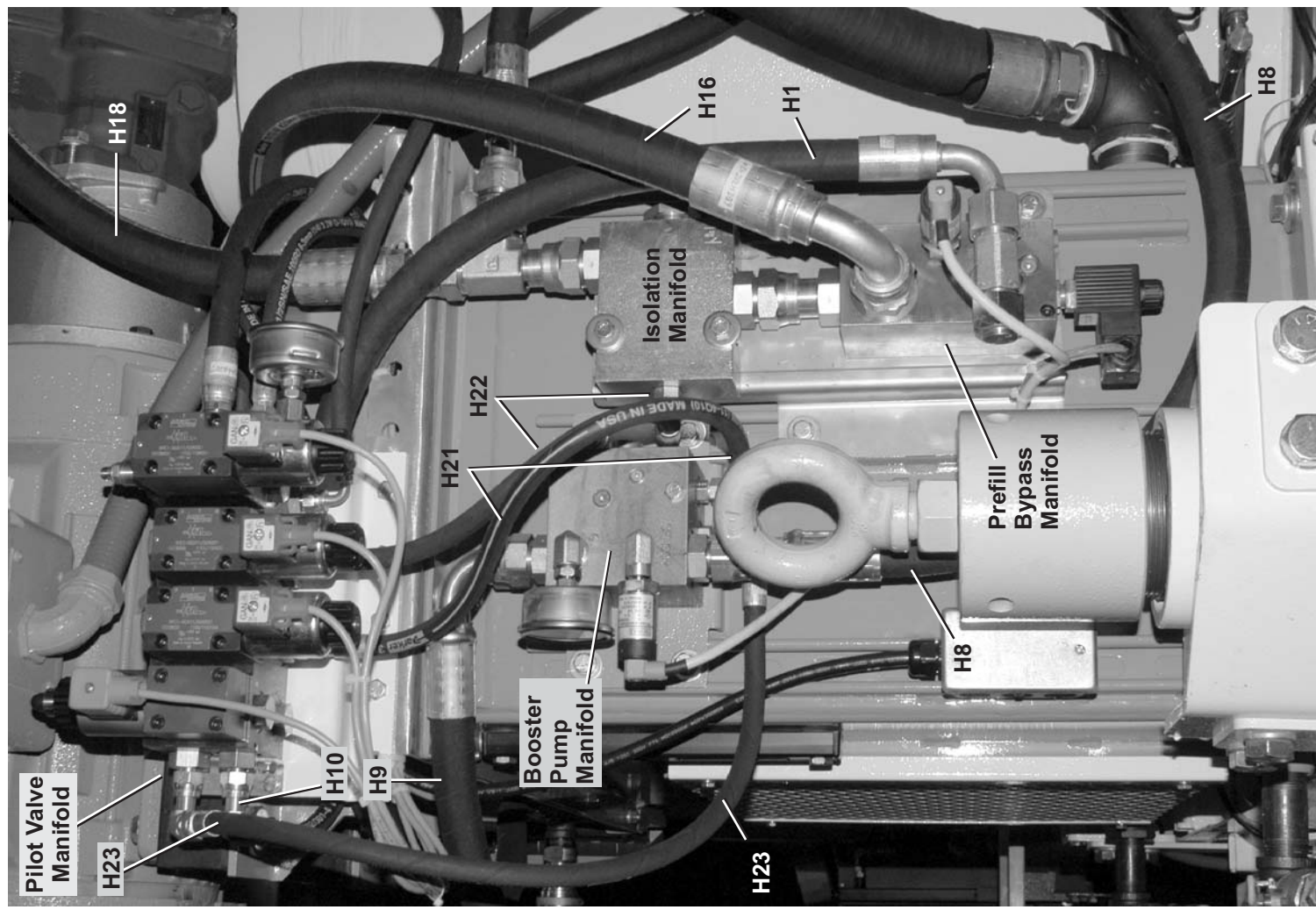

Booster Pump

Hydraulic Hoses
MP1556, *MP1640, MP1656

BMP110036/2012055B
 (7 / 9)



Pellerin Milnor Corporation
 P. O. Box 400, Kenner, LA 70063-0400

Litho in U.S.A.

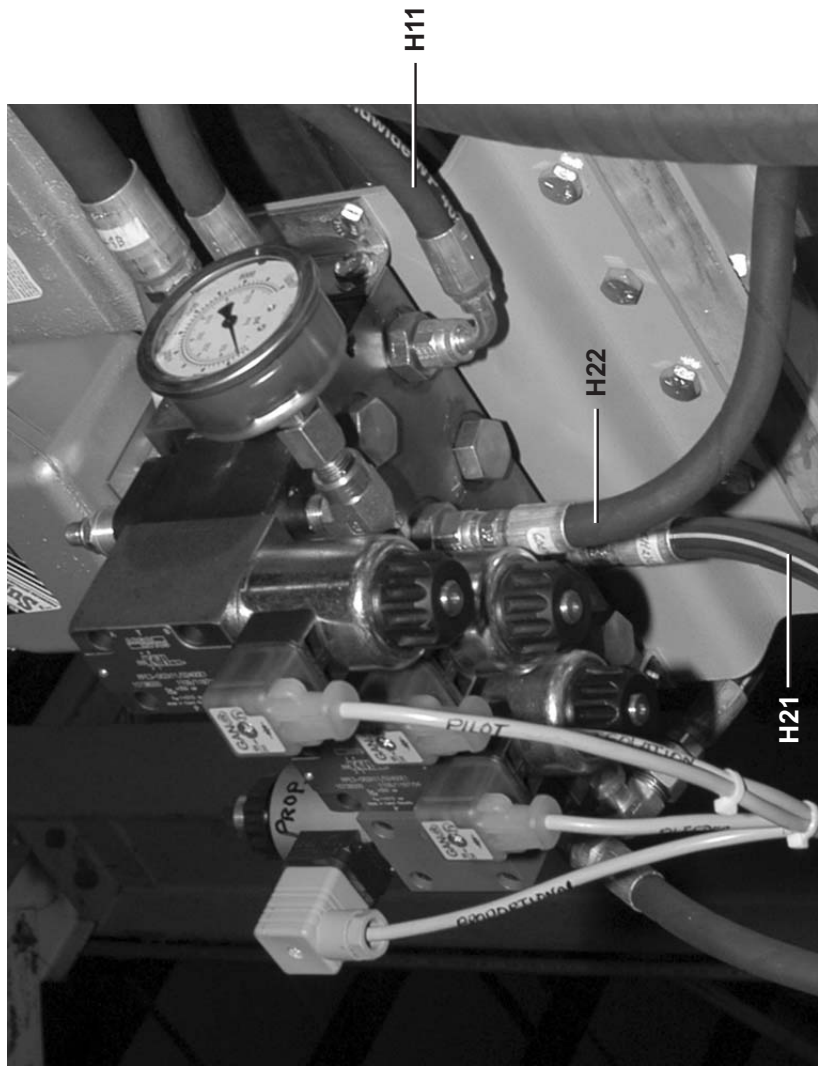
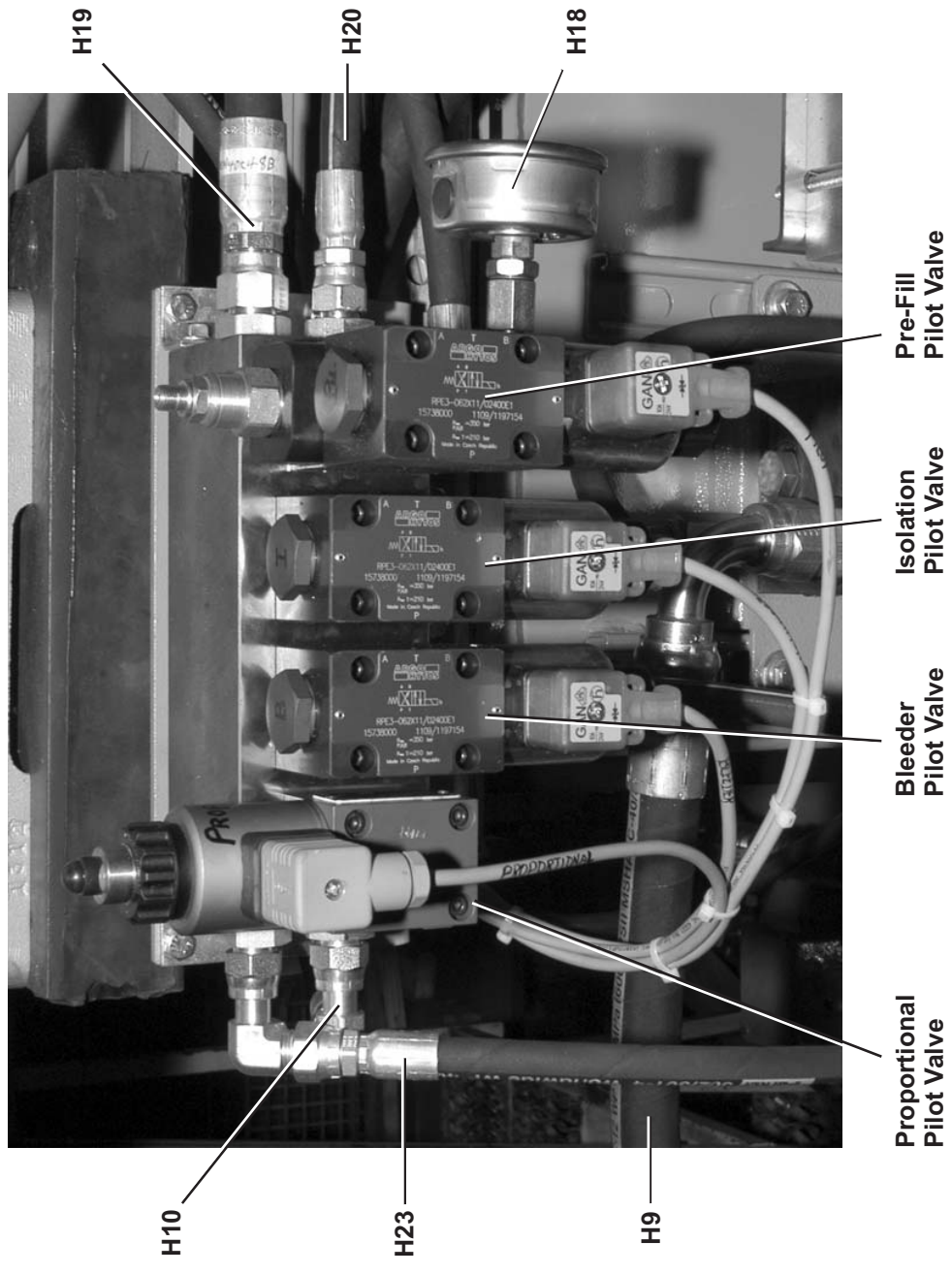

Hydraulic Hoses
MP1556, *MP1640, MP1656

BMP110036/2012055B
 (8 / 9)



Pellerin Milnor Corporation
 P. O. Box 400, Kenner, LA 70063-0400

Litho in U.S.A.

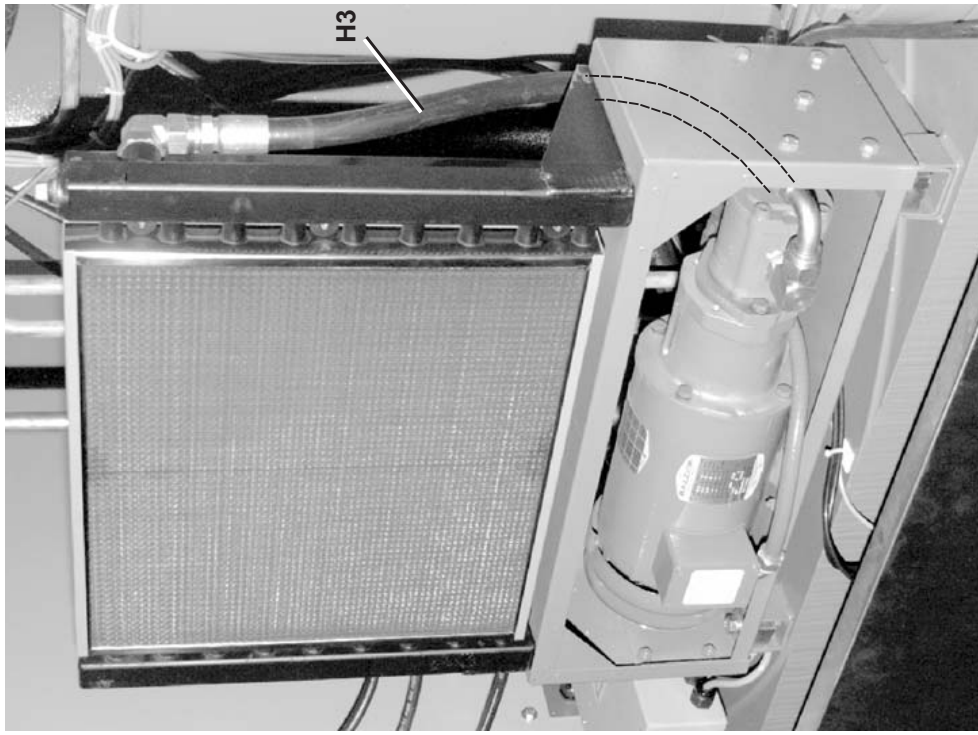

Cooler Pump

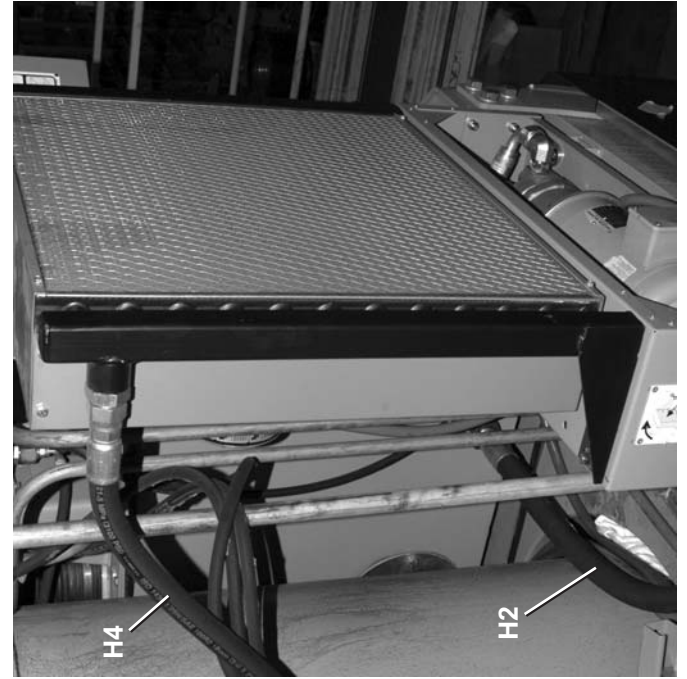



Pellerin Milnor Corporation
P. O. Box 400, Kenner, LA 70063-0400

Litho in U.S.A.

Parts List—Hydraulic Hoses MP1556,MP1640,MP1656
Find the correct assembly first, then find the needed components. The item letters (A, B, C, etc.) assigned to assemblies are referred to in the "Used In" column to identify which components belong to an assembly. The item numbers (1, 2, 3, etc.) assigned to components relate the parts list to the illustration.

Used In		Item	Part Number	Description	Comments
		A	GHC10027	HYD HOSES INSTL-MP1556/1656	MP1556, MP1656 *MP1640
-----ASSEMBLIES-----					
-----COMPONENTS-----					
all	H1	60EH50C60A		HYD.HOSE 3/4"+90FSWXFORSW=60"	
	H2	60EH80C44		HYD.HOSE 1"+ ENDS =44"LG.	
	H2	60EH80C32A		ASSY=HYDRAULIC HOSE 1"X32"LG	CENTER DISCHARGE LEFT/RIGHT DISCHARGE
all	H3	60EH50C32A		ASSY=HYDRAULIC HOSE 3/4X32LG	AIR/WATER COOLED
all	H4	60EH50C84A		HYD.HOSE 3/4"+ 90FSW + FORSW=84"	
all	H5	60EH95C33A		ASSY=HYDRAULIC HOSE 2"X33LG	
all	H6	60EH75C36A		ASSY=HYDRAULIC HOSE 1"X36"LG	
all	H7	60EH50C36A		HYD.HOSE 3/4"+90FSWXFORSW=36"	
all	H8	60EH51C54A		ASSY=HI-PRESSURE HOSE 3/4"X54"LG	
all	H9	60EH51C36A		ASSY=HI-PRESSURE HOSE 3/4"X36"LG	
all	H10	60EH21C40A		ASSY=HYDRAULIC HOSE 1/4 X40LG	
all	H11	60EH21C42A		ASSY=HYDRAULIC HOSE 1/4 X42LG	
all	H12	60E076B078		HOSE ASSY 1/4"X78"LG+ENDS	
all	H13	60EH21C60C		ASSY=HYD HOSE 1/4X60 GA SSPRES	
all	H14	60EH21C60B		ASSY=HYD HOSE 1/4X60 GAGE SSPR	
all	H15	60EH21C60B		ASSY=HYD HOSE 1/4X60 GAGE SSPR	
all	H16	60EH75C48A		ASSY=HYDRAULIC HOSE 1"X48"LG	
all	H17	60E025		4.5"X5.75" X 12"LG.#45A450575	
all	H18	60EH75C84A		ASSY=HYDRAULIC HOSE 1"X84"LG	
all	H19	60EH40C48B		HYD.HOSE 1/2"+ 90FSW + FORSW=48"	
all	H20	60EH21C42A		ASSY=HYDRAULIC HOSE 1/4 X42LG	
all	H21	60EH21C20A		ASSY=HYDRAULIC HOSE 1/4"X20"LG	
all	H22	60EH21C14A		ASSY=HYDRAULIC HOSE 1/4"X14"LG	
all	H23	60EH21C24B		ASSY=HYD HOSE 1/4 X24"LG	
all	H24	60EH80C15A		ASSY=HYDRAULIC HOSE 1"X15"LG	

Parts List, cont.—Hydraulic Hoses MP1556,MP1656

Used In	Item	Part Number	Description	Comments

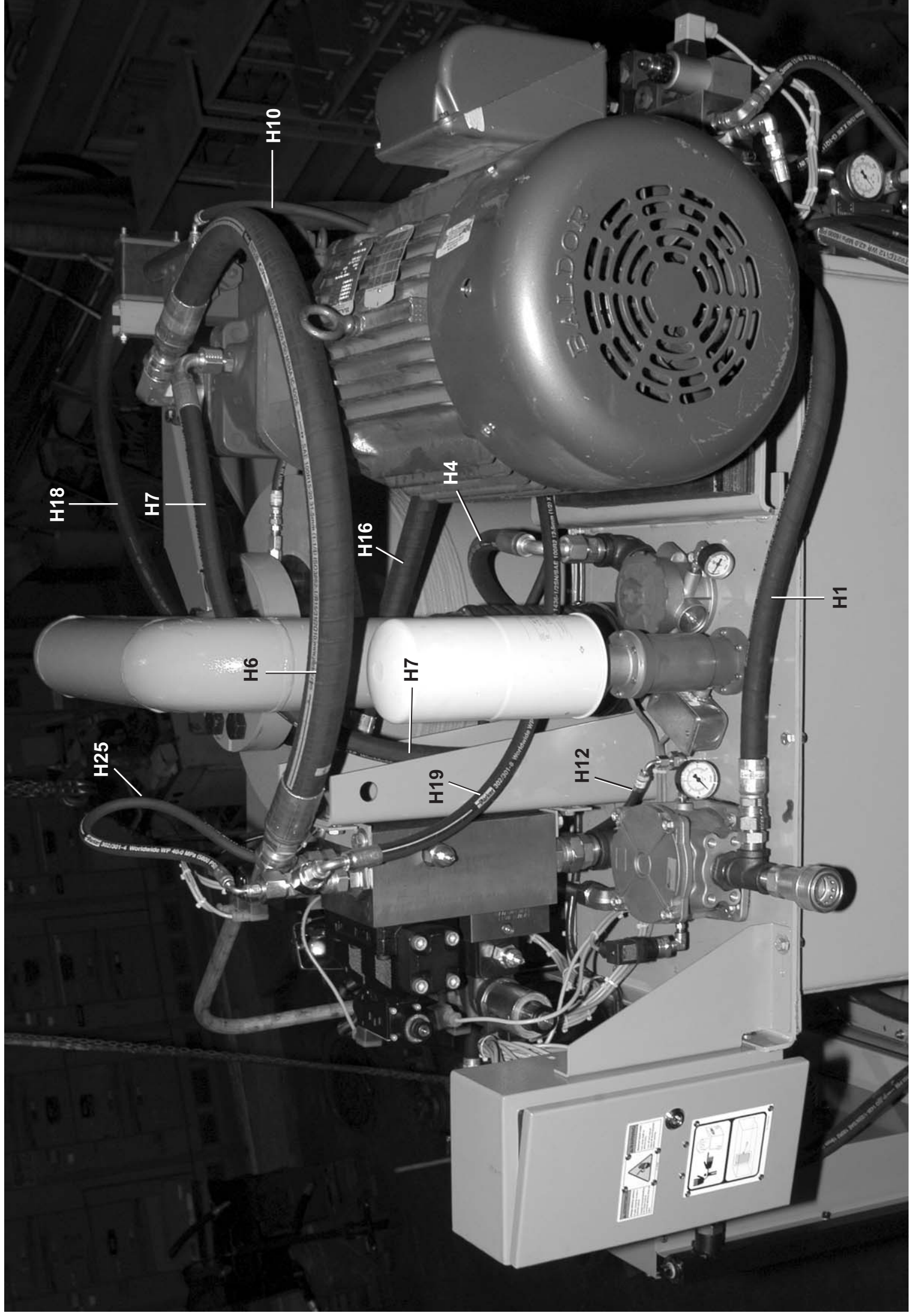

HOSES:

- H1) From Pre-fill Bypass to In-line Filter on Tank, 3/4" x 60"
- H2) From Tank to Cooler Pump
1" x 32" (Left/Right Discharge)
1" x 44" (Center Discharge)
- H3) From Cooling Pump to Cooler:
Air Cooled / Water Cooled, 3/4" x 32"
- H4) From Cooler to In-tank Return Filter, 3/4" x 96"
- H5) From Tank to Pressure Pump, 2-1/2" x 36"
- H6) Pressure Pump to Main Manifold, 1" x 36"
- H7) From Pressure Pump to Tank, 3/4" x 36"
- H8) From Booster Manifold to Isolation Manifold,
High Pressure, 3/4" x 54"
- H9) From Booster Pump to Booster Manifold,
High Pressure, 3/4" x 48"
- H10) From Main Pump to Proportional Pilot Valve, 1/4" x 40"
- H11) From bottom of Pre-fill Pilot to bottom of Main Manifold
1/4" x 42"
- H12) From Ram to Tank, 1/4" x 108"
- H13) Main System Pressure, 1/4" x 90"
- H14) Ram Relief, 1/4" x 90"
- H15) Can Relief, 1/4" x 90"
- H16) From Pre-fill Bypass Manifold to side of Main Manifold,
1" x 48"
- H17) Pre-fill Pipe to Tank, 4.5" x 12"
- H18) From Isolation Manifold to Pre-fill Valve, 1" x 84"
- H19) From Pre-fill Pilot to front of Main Manifold, 1/2" x 48"
- H20) From Pre-fill Pilot to Pre-fill Valve, 1/4" x 48"
- H21) From Booster Pump Manifold to bottom of
Bleeder Valve, 1/4" x 20"
- H22) From Isolation Manifold to Isolation Valve,
1/4" x 14"
- H23) From Proportional Pilot Valve to bottom of Booster
Pump Manifold, 1/4" x 24"
- H24) From Tank to Booster Pump, 1" x 15"
- H25) Bypass from top of Main Manifold to side of Main
Manifold, 1/4" x 14"



Pellerin Milnor Corporation
P. O. Box 400, Kenner, LA 70063-0400

Litho in U.S.A.

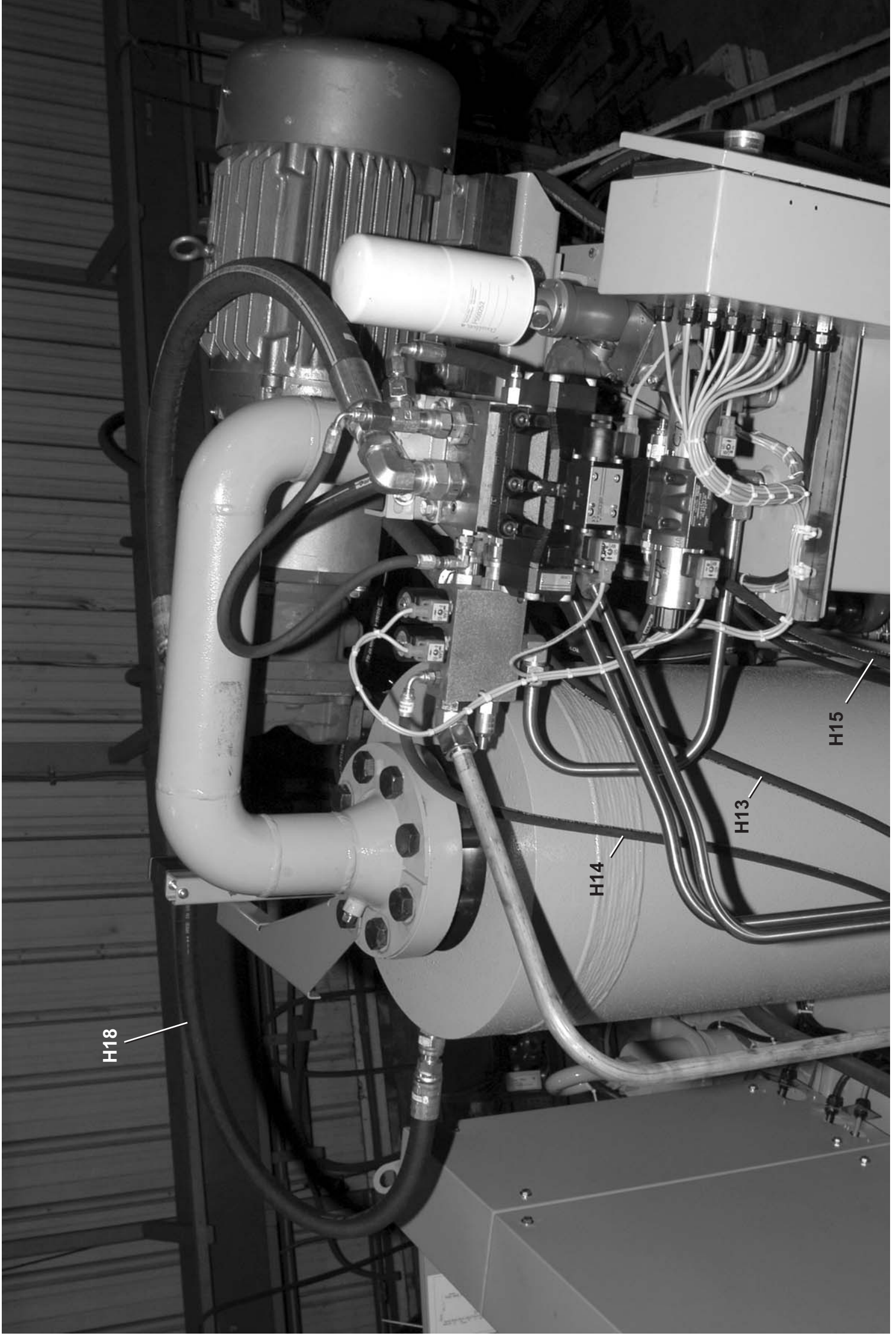



Pellerin Milnor Corporation
P. O. Box 400, Kenner, LA 70063-0400

Litho in U.S.A.

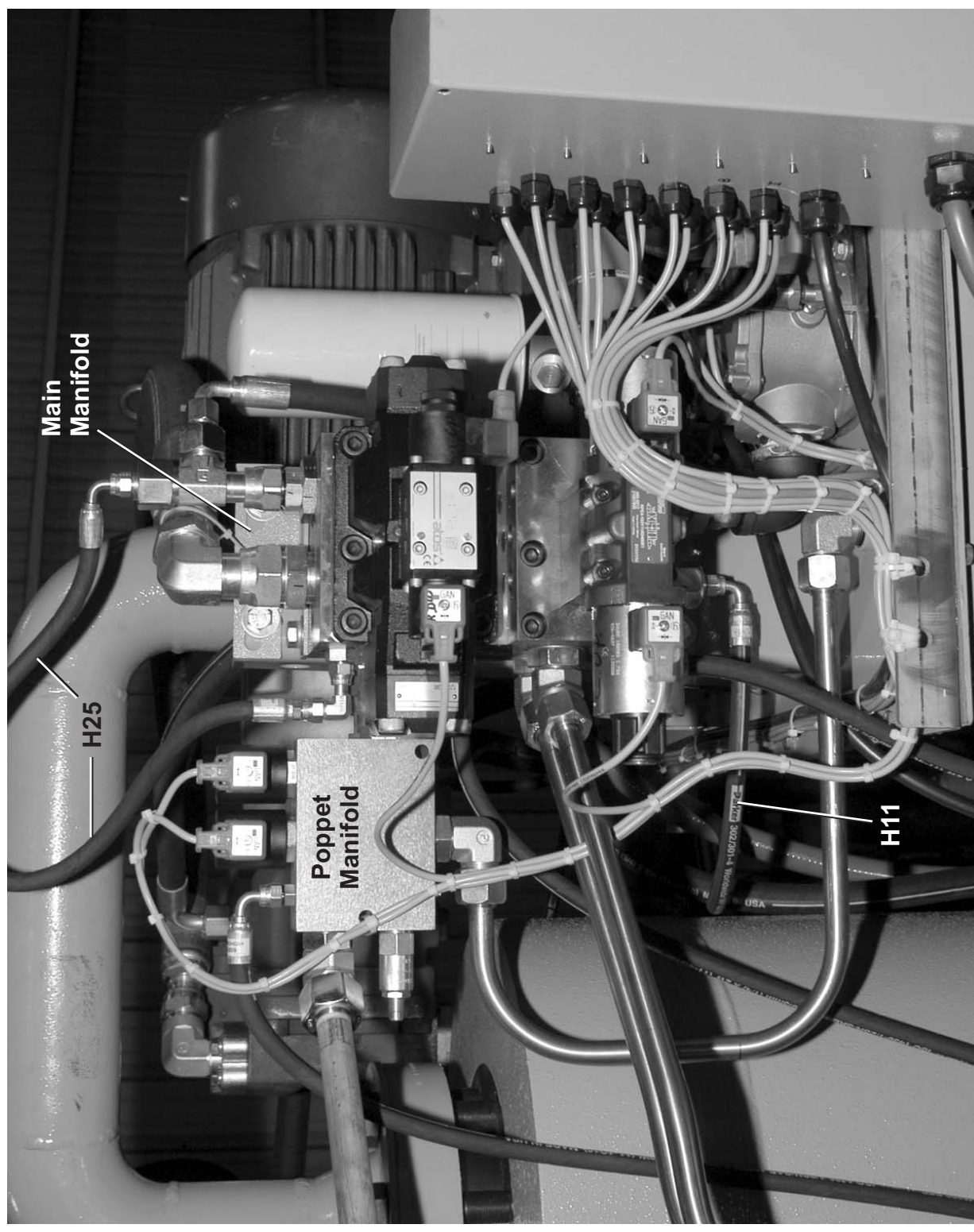
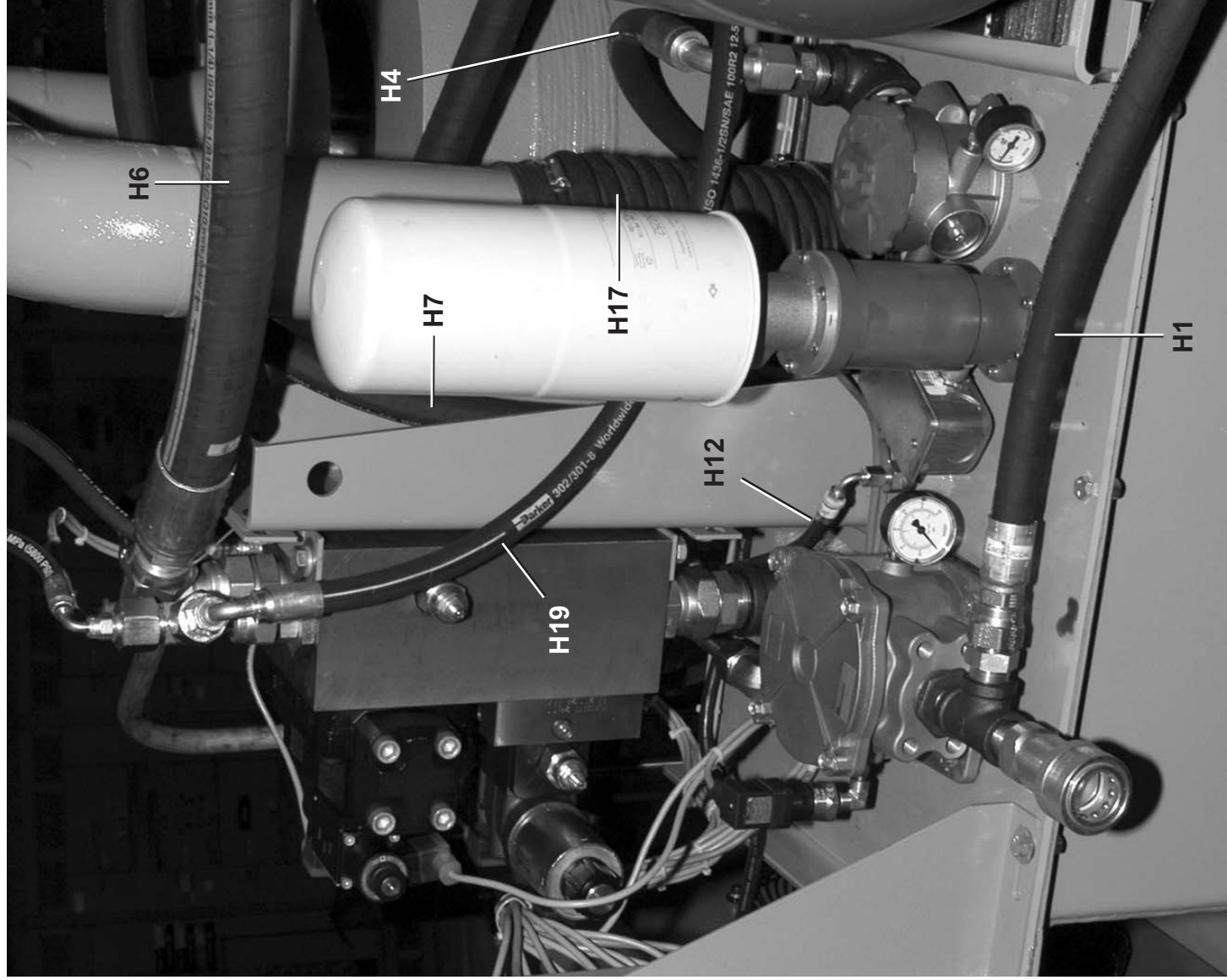



Pellerin Milnor Corporation
P. O. Box 400, Kenner, LA 70063-0400

Litho in U.S.A.

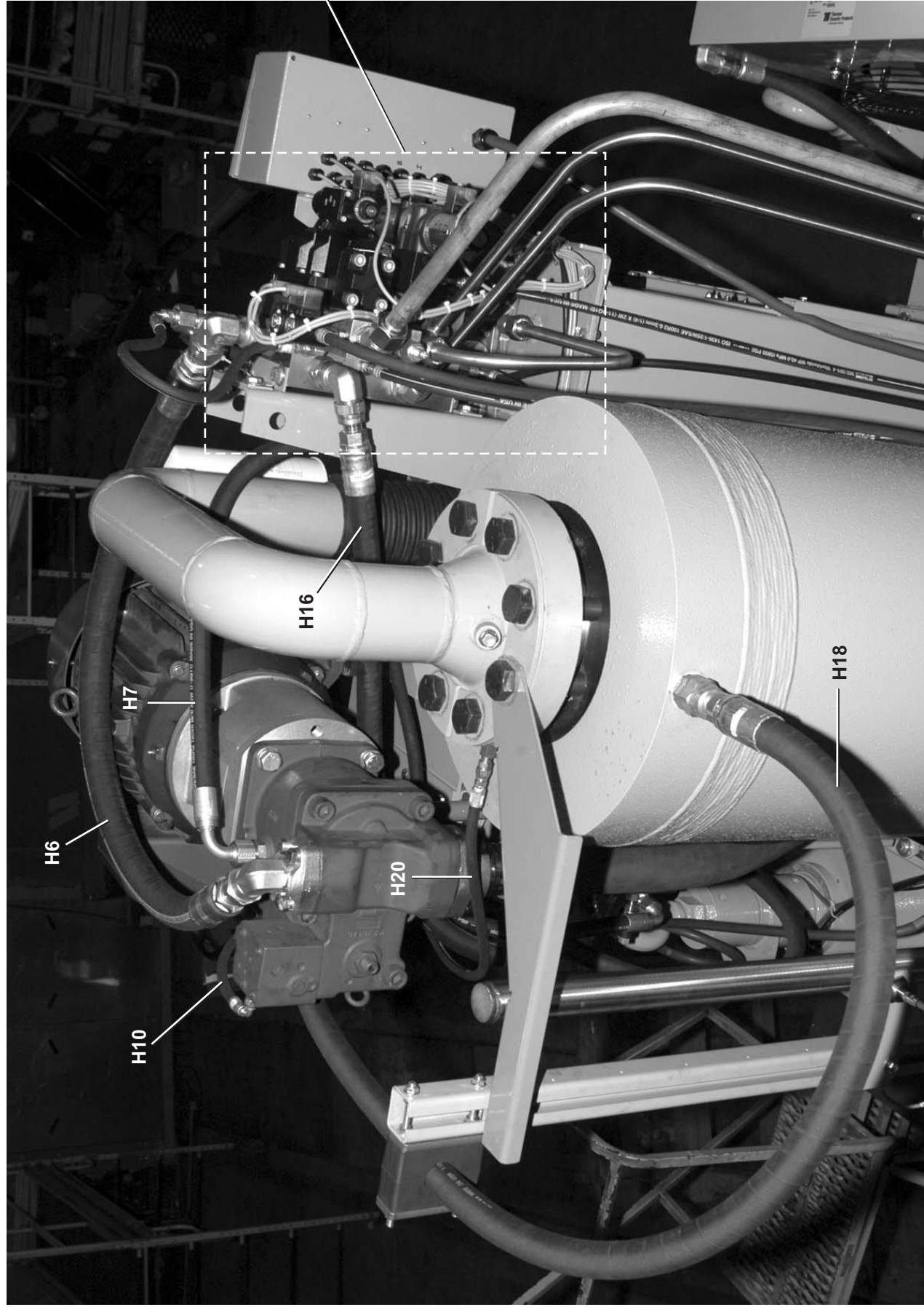
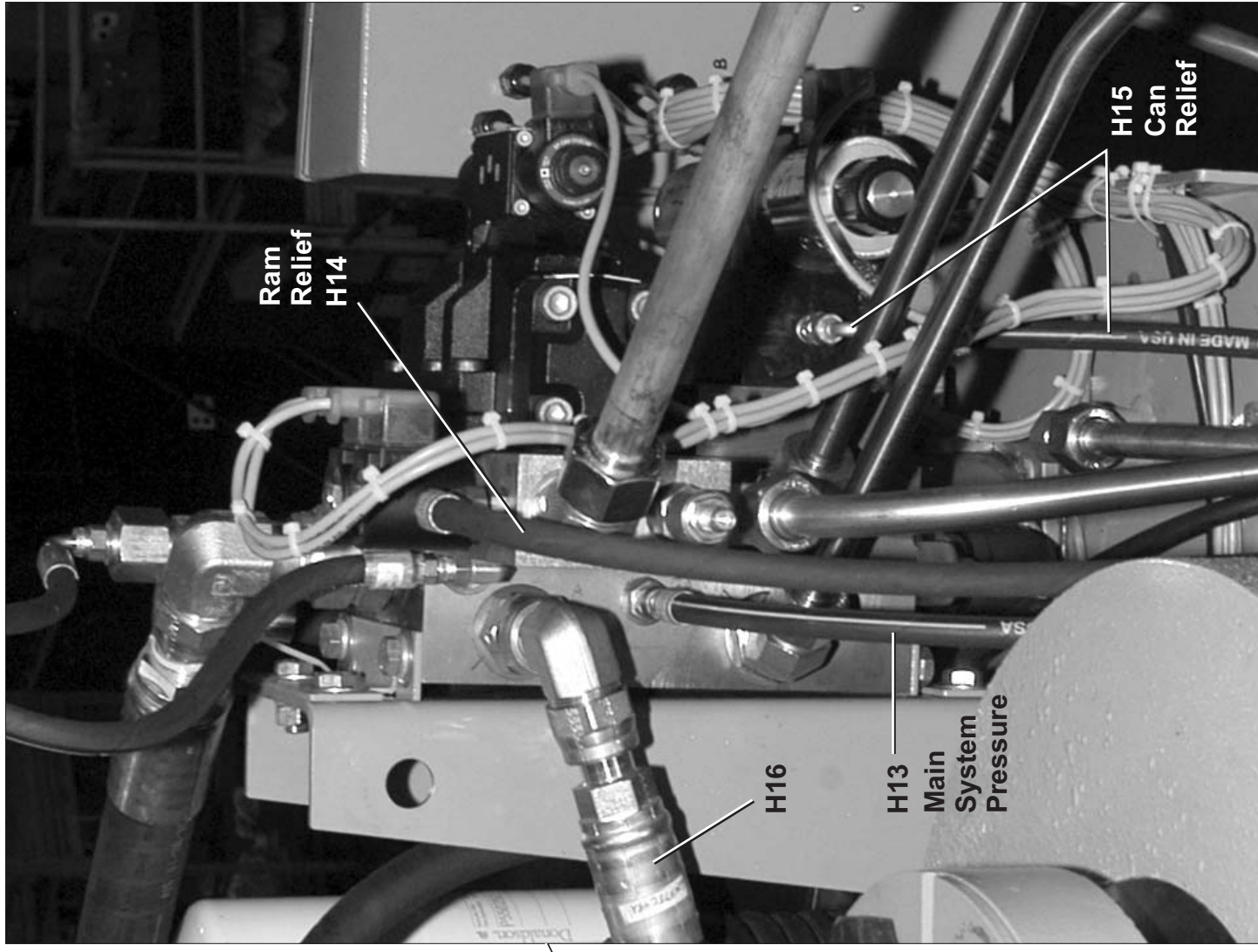



Pellerin Milnor Corporation
P. O. Box 400, Kenner, LA 70063-0400

Litho in U.S.A.

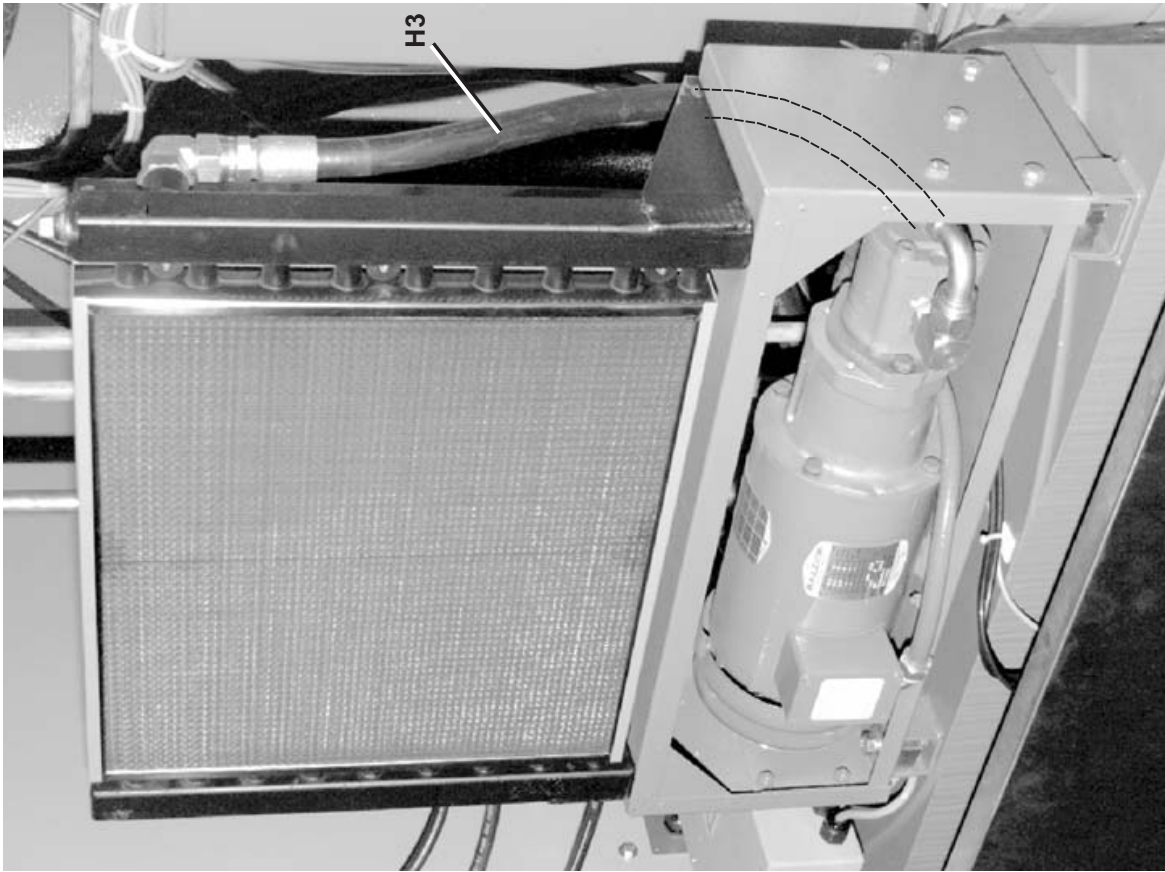

Cooler Pump

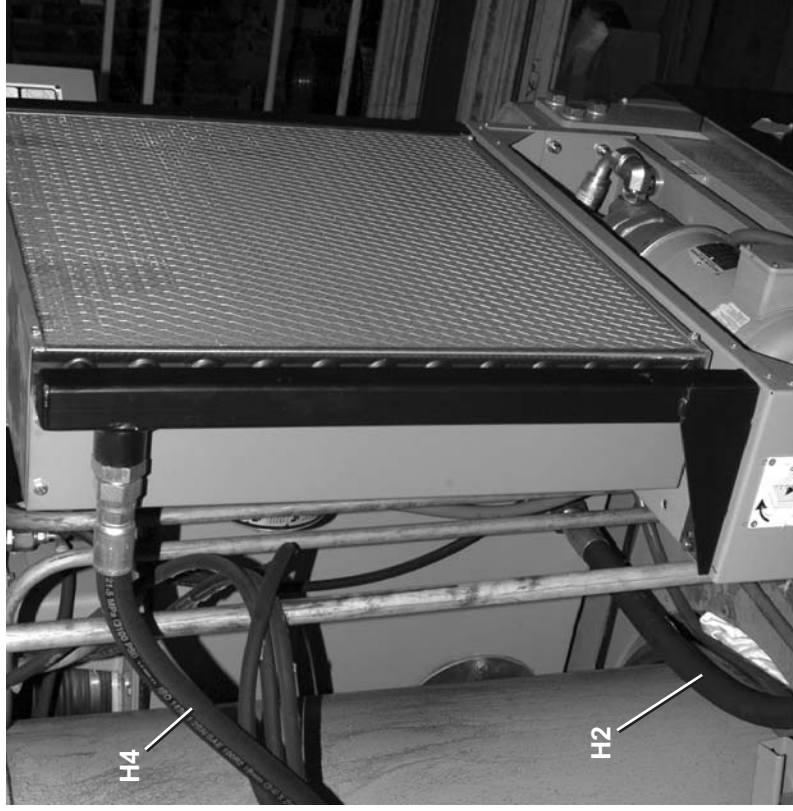

Booster Pump

Hydraulic Hoses
MP1A50



Pellerin Milnor Corporation
P. O. Box 400, Kenner, LA 70063-0400

BMP110045/2014533B
(6 / 7)

Litho in U.S.A.

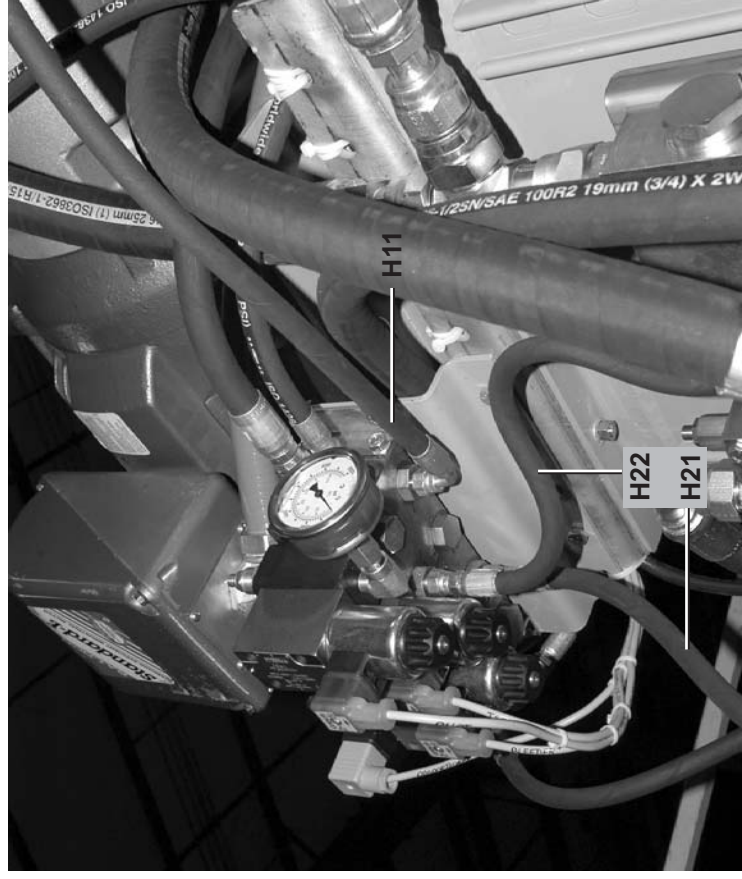
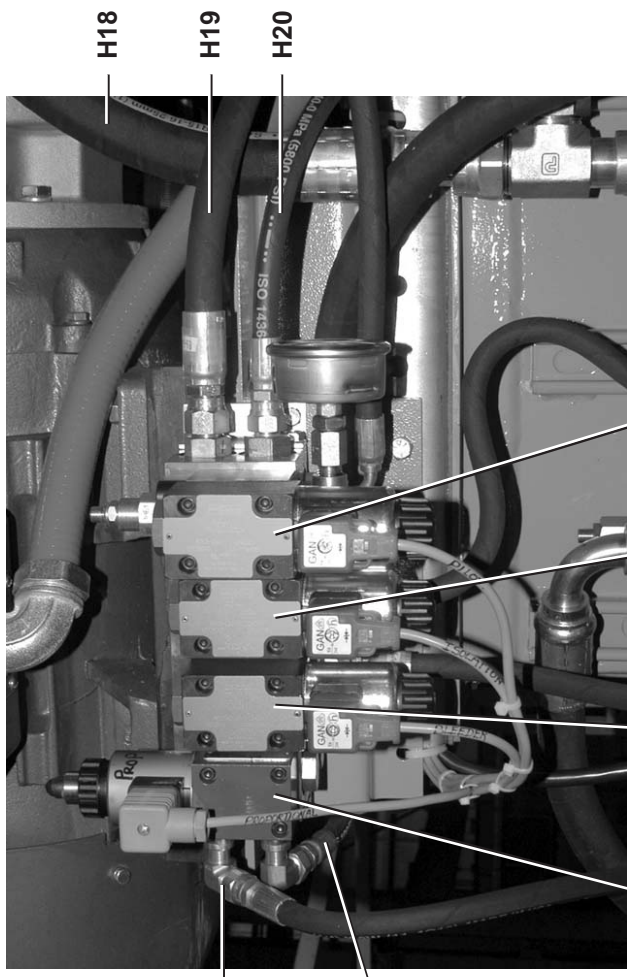
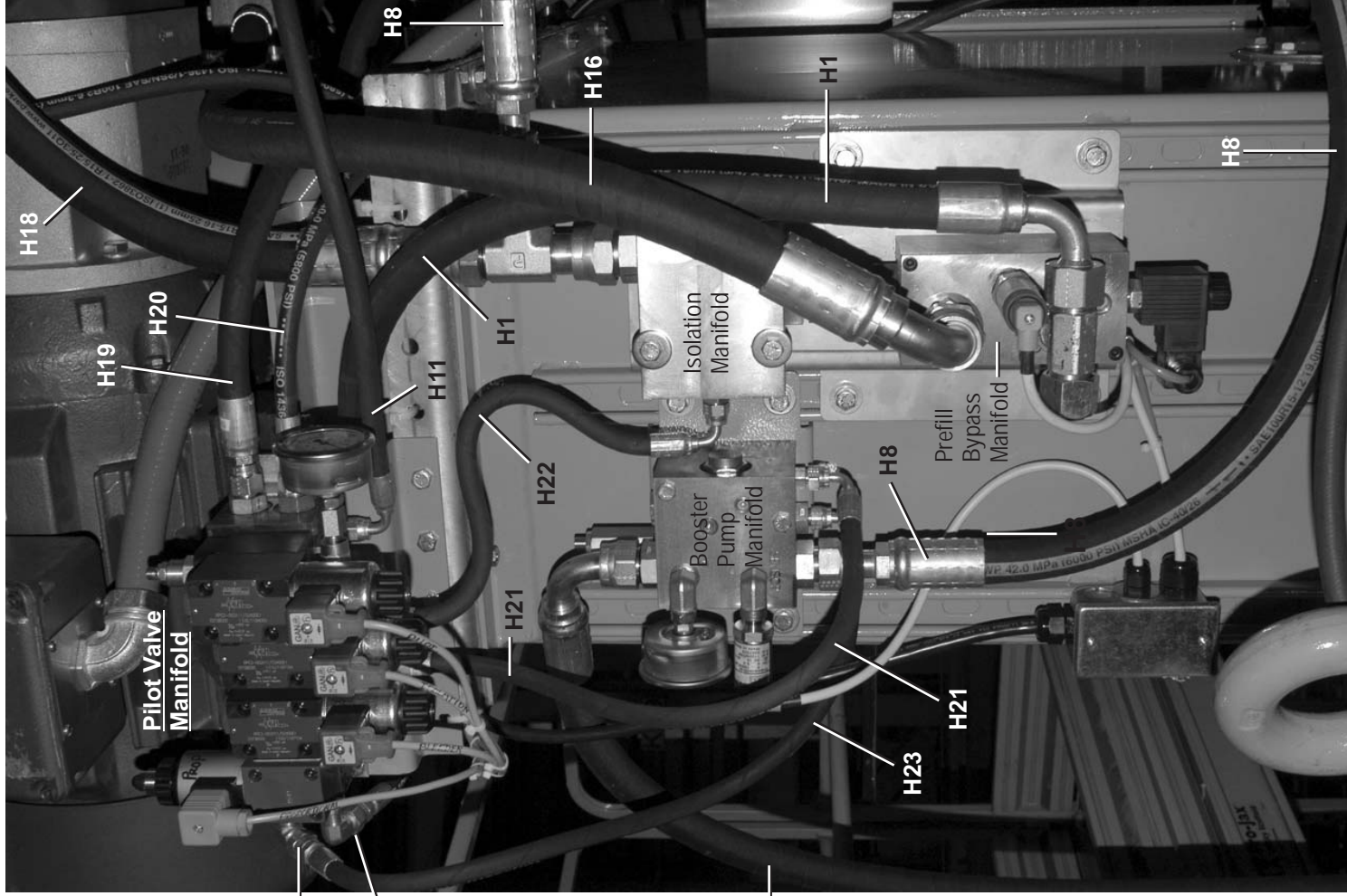



Pellerin Milnor Corporation
P. O. Box 400, Kenner, LA 70063-0400

Litho in U.S.A.

Used In		Item	Part Number	Description	Comments
<p>Parts List—Hydraulic Hoses MP1A56</p> <p>Find the correct assembly first, then find the needed components. The item letters (A, B, C, etc.) assigned to assemblies are referred to in the "Used In" column to identify which components belong to an assembly. The item numbers (1, 2, 3, etc.) assigned to components relate the parts list to the illustration.</p>					
<p>-----ASSEMBLIES-----</p>					
A		GHC10028		HYD HOSES INSTL-MP1A50/56	
<p>-----COMPONENTS-----</p>					
all	H1	60EH50C60A		HYD.HOSE 3/4"+90FSWXFORSW=60"	
all	H2	60EH80C44		HYD.HOSE 1"+ ENDS =44"LG.	
all	H2	60EH80C32A		ASSY=HYDRAULIC HOSE 1"X32"LG	CENTER DISCHARGE LEFT/RIGHT DISCHARGE
all	H3	60EH50C32A		ASSY=HYDRAULIC HOSE 3/4X32LG	
all	H4	60EH50C96A		ASSY=HYDRAULIC HOSE 3/4X96LG	
all	H5	60EH96		HYD.HOSE 2+1/2"ID SUCTION100R4	
all	H6	60EH75C36A		ASSY=HYDRAULIC HOSE 1"X36"LG	
all	H7	60EH50C36A		HYD.HOSE 3/4"+90FSWXFORSW=36"	
all	H8	60EH51C54A		ASSY=HI-PRESSURE HOSE 3/4"X54"LG	
all	H9	60EH51C48A		ASSY=HI-PRESSURE HOSE 3/4"X48"LG	
all	H10	60EH21C40A		ASSY=HYDRAULIC HOSE 1/4 X40LG	
all	H11	60EH21C42A		ASSY=HYDRAULIC HOSE 1/4 X42LG	
all	H12	60E076B108		HOSE ASSY 1/4"X108"LG+ENDS	
all	H13	60EH21C90C		ASSY=HYD HOSE 1/4X90 GA MP1A03	
all	H14	60EH21C90B		ASSY=HYD HOSE 1/4X90 GA MP1A03	
all	H15	60EH21C90B		ASSY=HYD HOSE 1/4X90 GA MP1A03	
all	H16	60EH75C48A		ASSY=HYDRAULIC HOSE 1"X48"LG	
all	H17	60E025		4.5"/5.75" X 12"LG.#45A450575	
all	H18	60EH75C84A		ASSY=HYDRAULIC HOSE 1"X84"LG	
all	H19	60EH40C48B		HYD.HOSE 1/2"+ 90FSW + FORSW=48"	
all	H20	60EH21C48B		ASSY=HYD HOSE 1/4X48"LG	
all	H21	60EH21C20A		ASSY=HYDRAULIC HOSE 1/4"X20"LG	
all	H22	60EH21C14A		ASSY=HYDRAULIC HOSE 1/4"X14"LG	
all	H23	60EH21C24B		ASSY=HYD HOSE 1/4X24"LG	
all	H24	60EH80C15A		ASSY=HYDRAULIC HOSE 1"X15"LG	
all	H25	60EH21C14A		ASSY=HYDRAULIC HOSE 1/4"X14"LG	

Hydraulic Tank

MP1540, MP1556, MP1640, MP1656

BMP110023/2014373A
(1 / 6)



Pellerin Milnor Corporation
P. O. Box 400, Kenner, LA 70063-0400

Litho in U.S.A.

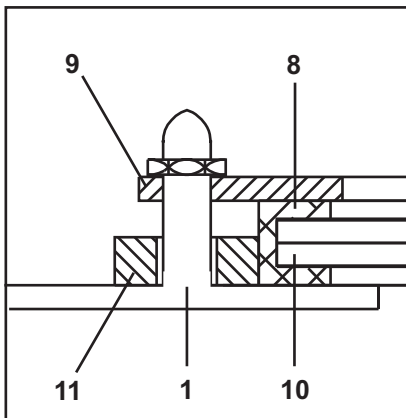
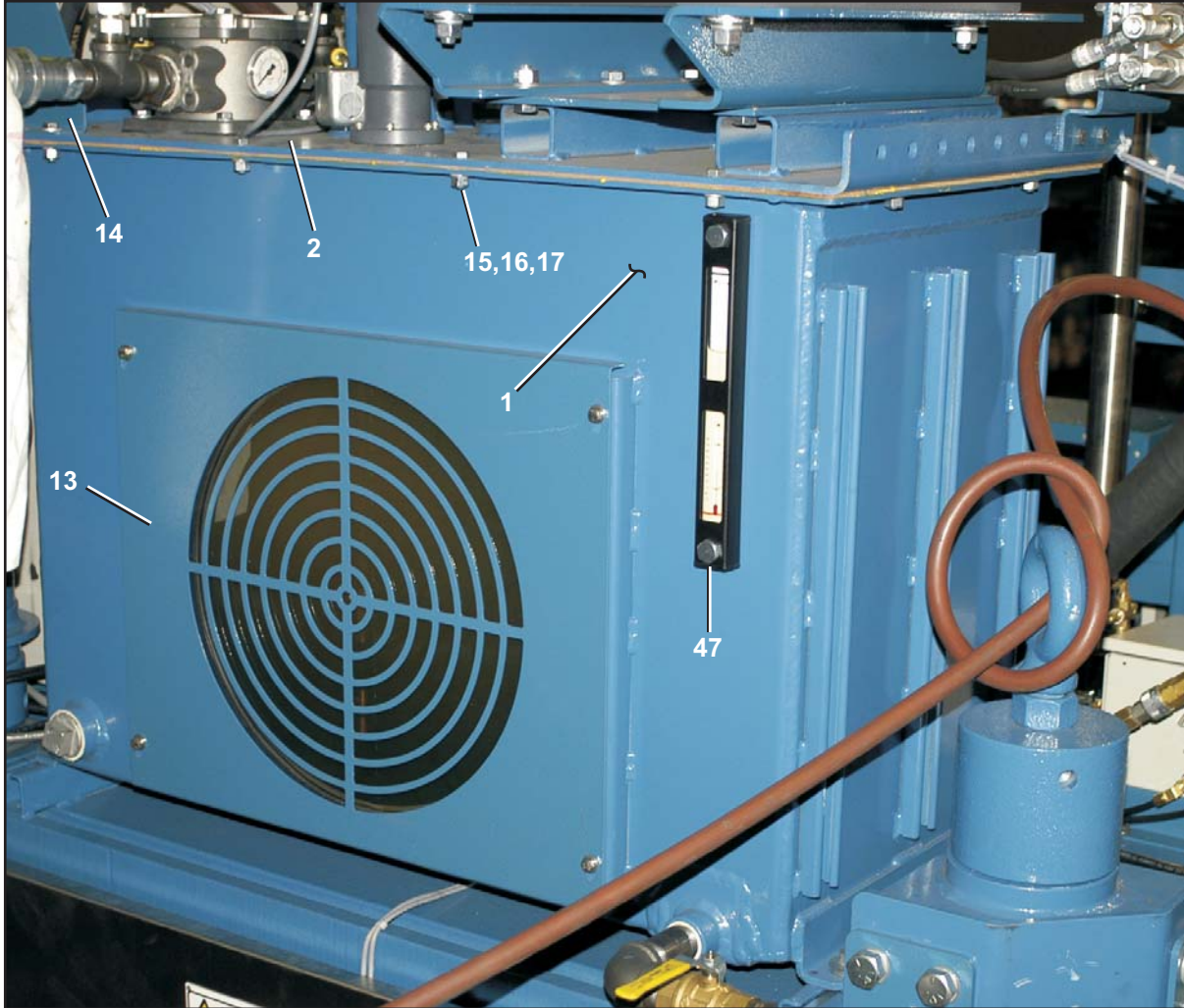

Detail: Tank glass

Hydraulic Tank

MP1540, MP1556, MP1640, MP1656

BMP110023/2014373A
(2 / 6)



Pellerin Milnor Corporation
P. O. Box 400, Kenner, LA 70063-0400

Litho in U.S.A.

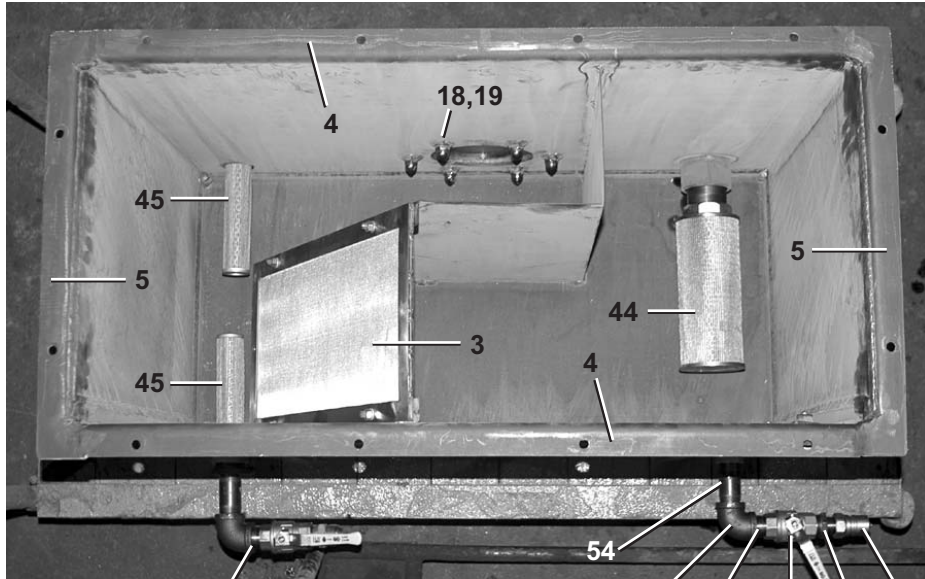

Used only with Booster Pump

55 56 57 58 59

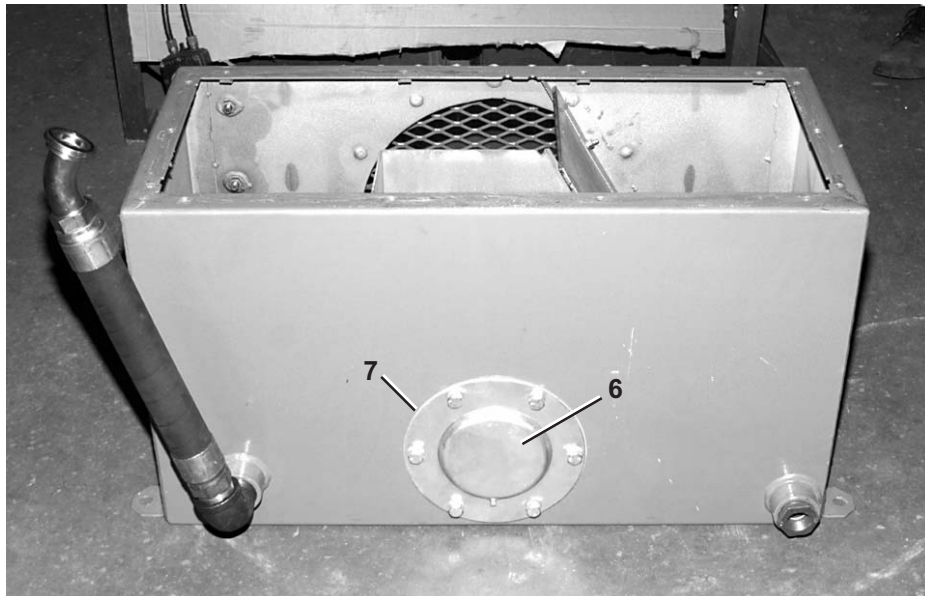

Hydraulic Tank

MP1540, MP1556, MP1640, MP1656

BMP110023/2014373A
(3 / 6)



Pellerin Milnor Corporation
P. O. Box 400, Kenner, LA 70063-0400

Litho in U.S.A.

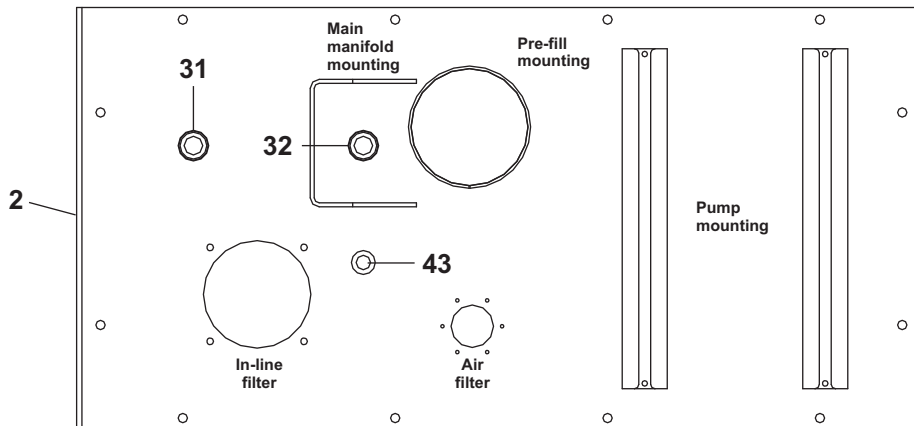
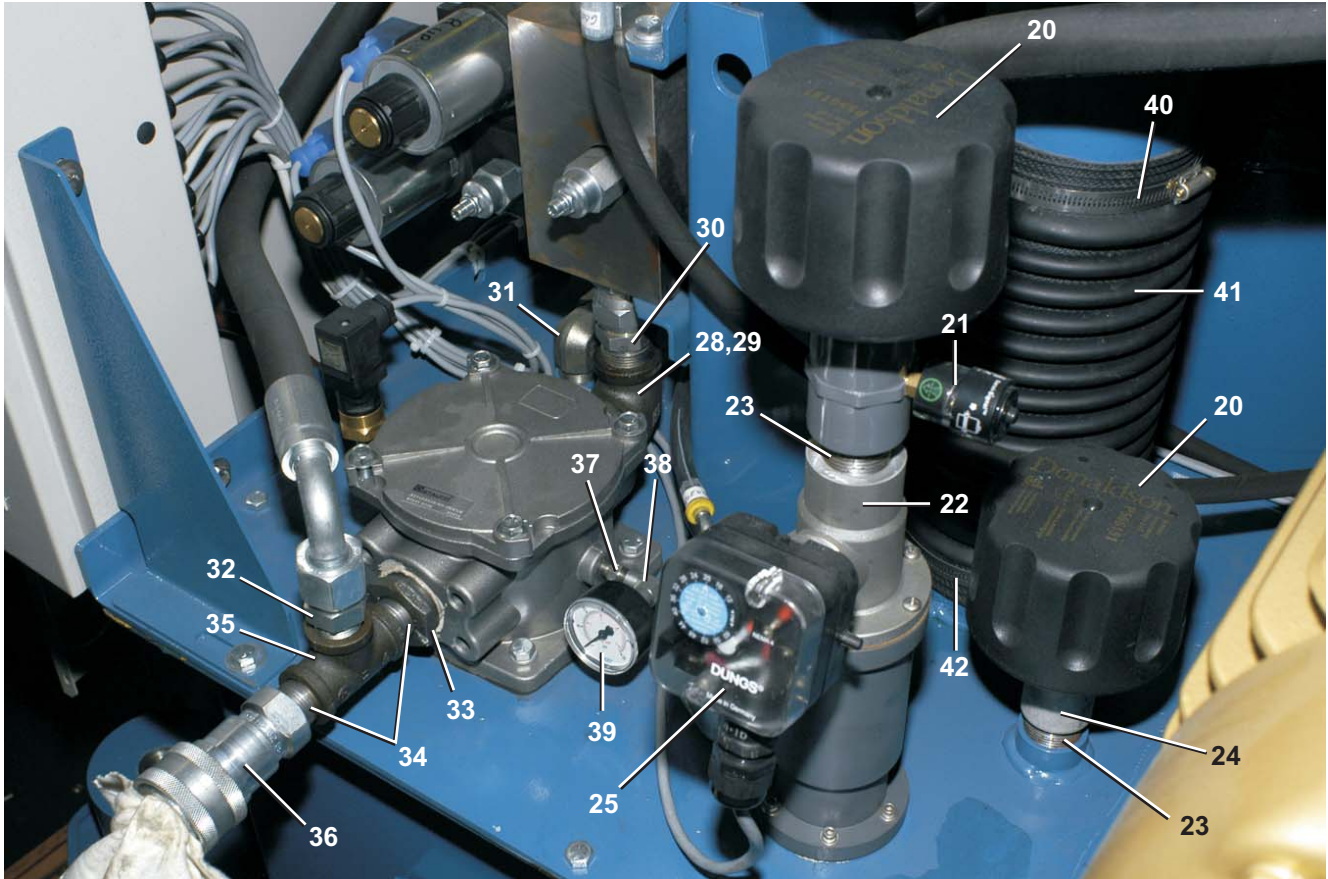

Hydraulic Tank

MP1540, MP1556, MP1640, MP1656

BMP110023/2014373A
(4 / 6)



Pellerin Milnor Corporation
P. O. Box 400, Kenner, LA 70063-0400

Litho in U.S.A.

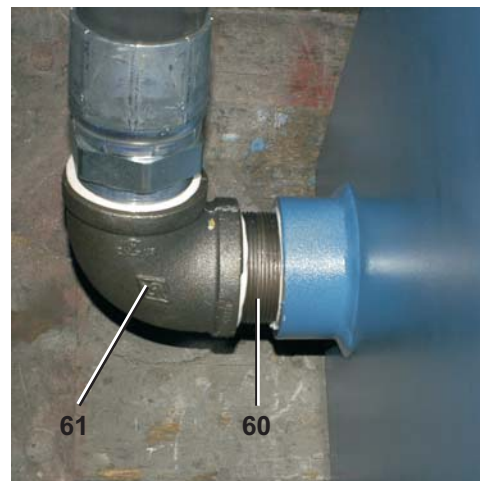
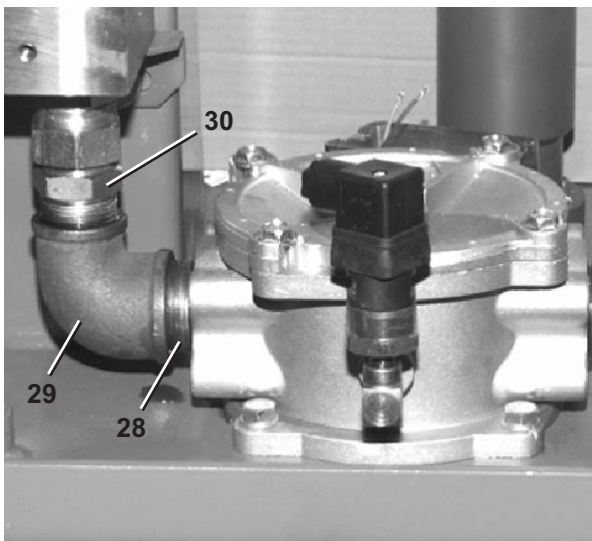
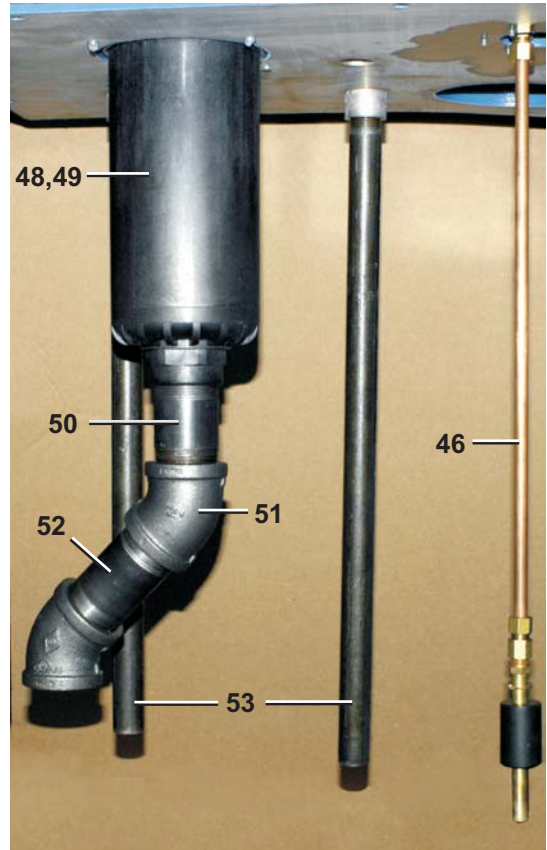
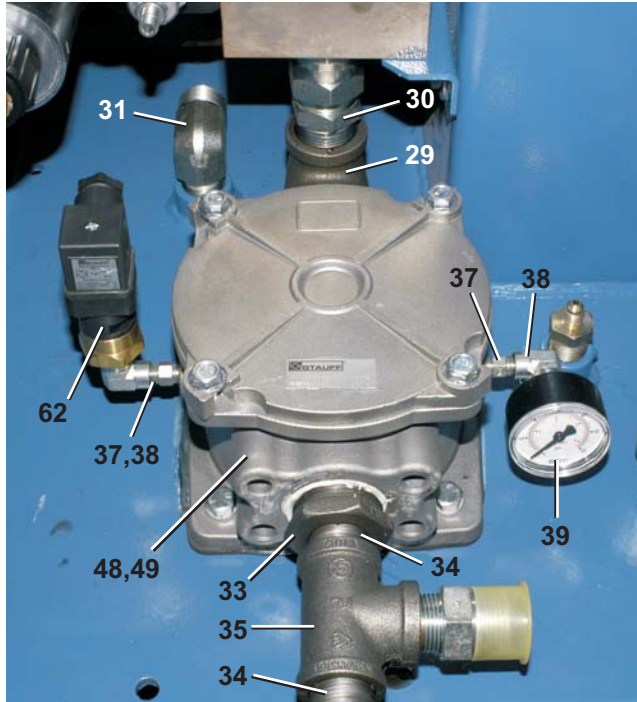

Hydraulic Tank

MP1540, MP1556, MP1640, MP1656

BMP110023/2014373A
(5 / 6)



Pellerin Milnor Corporation
P. O. Box 400, Kenner, LA 70063-0400

Litho in U.S.A.

Parts List—Hydraulic tank

Find the correct assembly first, then find the needed components. The item letters (A, B, C, etc.) assigned to assemblies are referred to in the "Used In" column to identify which components belong to an assembly. The item numbers (1, 2, 3, etc.) assigned to components relate the parts list to the illustration.

Used In	Item	Part Number	Description	Comments
			-----ASSEMBLIES-----	
	A	AHT10033B	OIL RESERVOIR ASSY-35/50BAR	
	B	AHT10041	HYDRAULIC TANK-MP16XX	
			-----COMPONENTS-----	
all	1	W7 10525	HYD OIL TANK WLMT-MP16XX	
all	2	W7 10527	OIL RESERVOIR TOP WLMT-MP16XX	
all	3	W7 60256	*COMB AIR SCREEN WLMT 5840GAS	
all	4	07 10530	HYDTANK TOP GASKET-LONG SIDE	
all	5	07 10530A	HYDTANK TOP GASKET-SHORT SIDE	
all	6	02 18618	COVER=BEARHOUSE	
all	7	02 18105A	HYD TANK COVER GASKET	
all	8	02 12054A	DOORGLASS GASKET-NITRILE BLK	
all	9	02 11904P	RING=GLASS RETAINER-4226RWP	
all	10	02 12008	DOORGLASS 17"DIA=4226W DOOR	
all	11	X7 10311	DOOR GLASS SPACER -MACHINED	
all	13	07 10710	HYD TANK GLASS GUARD	
all	14	07 10556	JUNCTION BOX BRKT	
all	15	15K095	HXCPSCR 3/8-16UNC2AX1 GR5 ZINC	
all	16	15U240	FLATWASHER(USS STD) 3/8" ZNC P	
all	17	15G205	HXNUT 3/8-16UNC2B ZINC GR2	
all	18	15K145	HXCAPSCR 1/2-13UNC2AX3/4 GR5 P	
all	19	15U300	LOKWASHER REGULAR 1/2 ZINC PLT	
all	20	27E7115	BREATHER 45CFM DONALDSON P566151	
all	21	27E7115A	INDICATOR KIT DONALDSON P566168	
all	22	X7 10700	BREATHER ADAPTER 1" FNPT	
all	23	5N1ACLSS42	NPT NIP 1XCLS TBE 304SS SK 40	
all	24	5SCC1ASF	NPT COUP 1" SS304 150#	
all	25	09N19115	AIR PRESSW 12-60"WC DUNGS	
all	28	5N1ECLSF42	NPT NIP 1.25XCLS TBE BLKSTLS40	
all	29	5SL1EMFA1A	NPT ELBOW 90DEG 1.25X1" BLKMAL	
all	30	52XY1AP010	STRADPT 1"MXMJIC #2404-16-16	
all	31	52ZJ00S007	TUBEFIT90ELFCSL3/4"#12CLO-S	

Hydraulic Tank

MP1540, MP1556, MP1640, MP1656

BMP110023/2014373A
(6 / 6)



Pellerin Milnor Corporation
P. O. Box 400, Kenner, LA 70063-0400

Litho in U.S.A.

Parts List, Hydraulic tank

Find the correct assembly first, then find the needed components. The item letters (A, B, C, etc.) assigned to assemblies are referred to in the "Used In" column to identify which components belong to an assembly. The item numbers (1, 2, 3, etc.) assigned to components relate the parts list to the illustration.

Used In	Item	Part Number	Description	Comments
all	32	52ZC0PS001	TUBEFITSTR3/4"#12-FLO-S	
all	33	5SB1E0PMFO	NPTHEXBUSH 1.25X3/4 BLKML 150#	
all	34	5N0PCLSF42	NPT NIP 3/4XCLS TBE BLKSTLSK40	
all	35	5S0PMFA	NPT TEE 3/4" BLKMAL 150#	
all	36	52XY0BP00X	3/4"QUICK DISCONN.FEM #H6-62	
all	37	52LY0CR001	HEXPIP NIP 1/8"XCLOSE#5404-2-2	
all	38	52JY0CR001	ELBOW 1/8"FEM.#5504-02-02	
all	39	30N101	PRESSGAUGE 1/8"BACKCN.0-60PSI	
all	40	27A086	HOSECLAMP 3+1/8-6"CADSCR#HS-88	
all	41	60E025	4.5"/5.75" X 12"LG.#45A450575	
all	42	27A087	HOSECLAMP 4+1/16-5"CADSCR#HS72	
all	43	52AY0ER009	STR.1/4"MJICX1/2MP#2404-4-8	
all	44	27E7108	SUCTION STRAINER 2" PORT	
all	45	27E7111	SUCT.STRAINER=EZYFLO#S-15-100	
all	46	27E7200	LEVEL/TEMP INDICATOR SWITCH ASSY	
all	47	27E7303	LEVEL INDICATOR W/THERM-STAUFF	
all	48	27E7106	IN-LINE RETURN FILTER	
all	49	27E7106A	FILTER ELEMENT-REPLACEMENT	
all	50	5N1K05KF42	NPT NIPPLE 1.5X5.5 TBE BLKSTL	
all	51	5SL1KMFK	NPT ELBOW 45DEG 1.5" BLK 1	
all	52	5N1K03KF42	NPT NIP 1.5X3.5 TBE BLKSTL S40	
all	53	5N0P22AF41	NPT NIP 3/4X22 TOE BLKSTL SK40	
all	54	5N1A03KF42	NPT NIP 1X3.5 TBE BLK STL SK40	
all	55	5SL1AMFA	NPT ELBOW 90DEG 1" BLKMAL 150#	
all	57	96D084	BALL VALVE BRZ 1"BONOMI 171N	
all	58	5SB1A0PFEO	NPTHEXBUSH 1X3/4 BLKSTL 125#	
all	59	52XY0BP00Y	3/4"QUICK DISCONN.MALE#H6-63	
All	60	5N2ACLSB42	NPT NIP 2XCLS TBE BLKSTL SK40	
All	61	5SL2AMFA	NPT ELB 90DEG 2" BLKMAL 150#	
All	62	27E7106C	EPS-1 - SWITCH=27E7106 STAUFF	

Hydraulic Tank MP1A50

BMP110044/2012052A
(1 / 6)



Pellerin Milnor Corporation
P. O. Box 400, Kenner, LA 70063-0400

Litho in U.S.A.

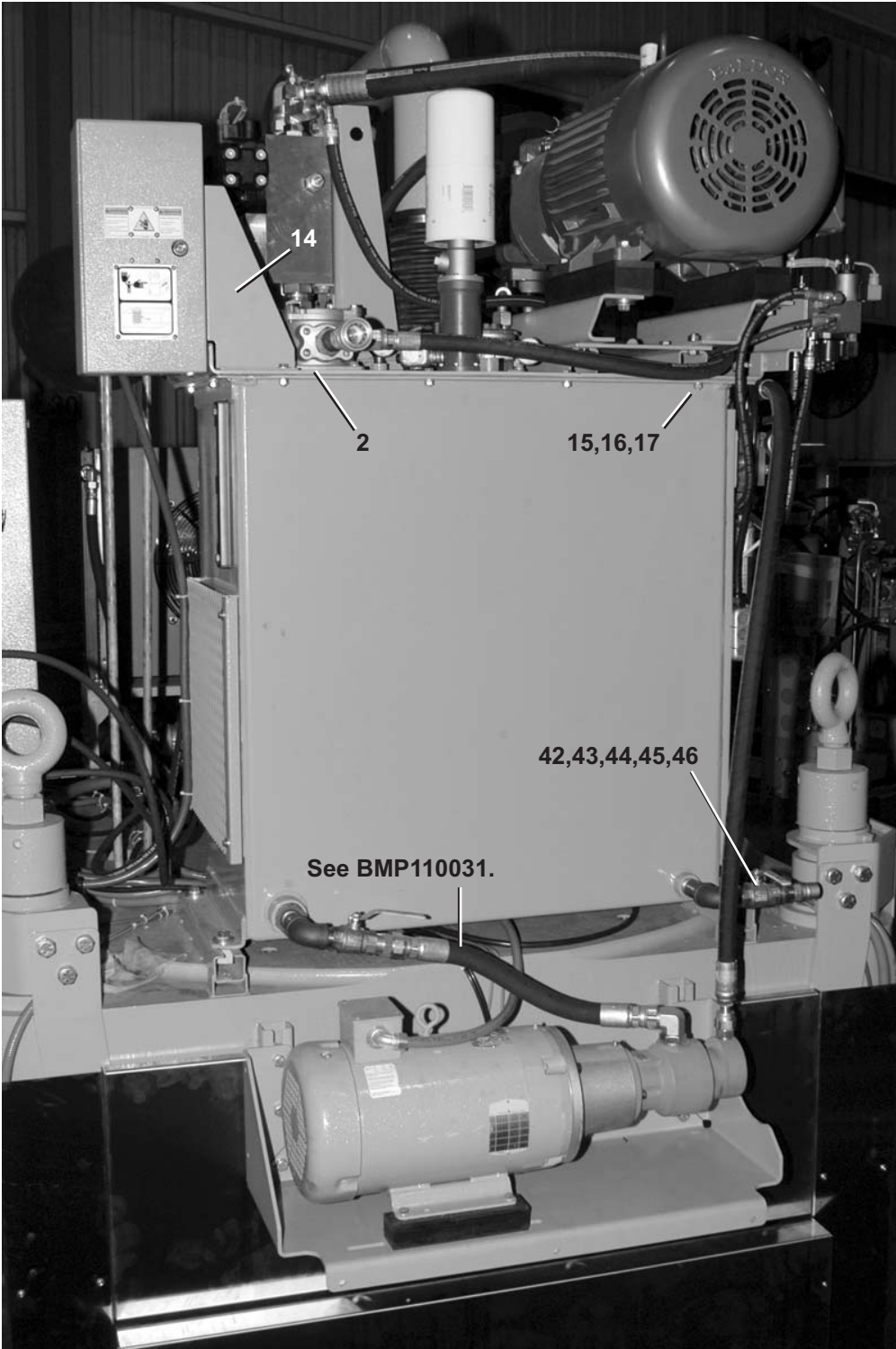

Hydraulic Tank

MP1A50

BMP110044/2012052A
(2 / 6)



Pellerin Milnor Corporation
P. O. Box 400, Kenner, LA 70063-0400

Litho in U.S.A.

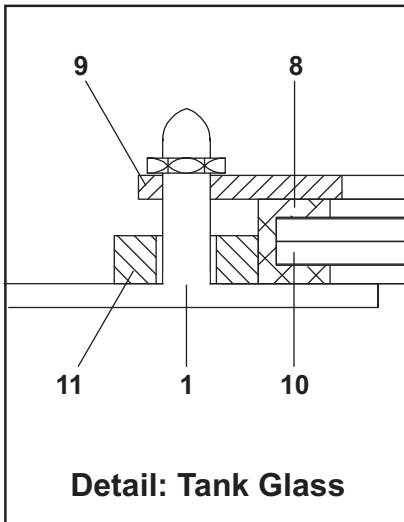
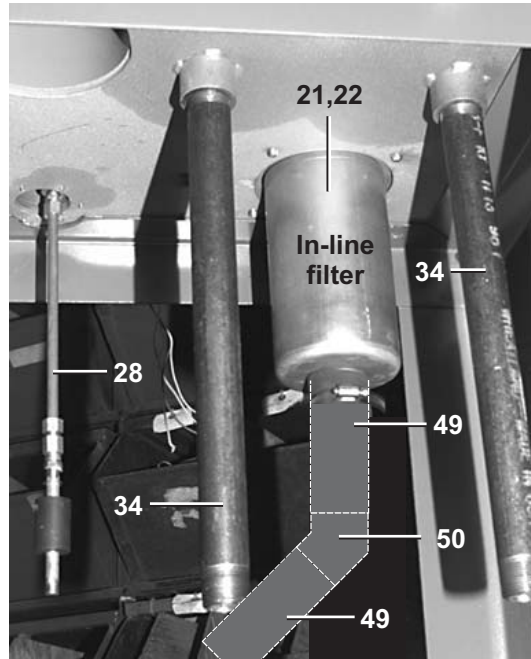
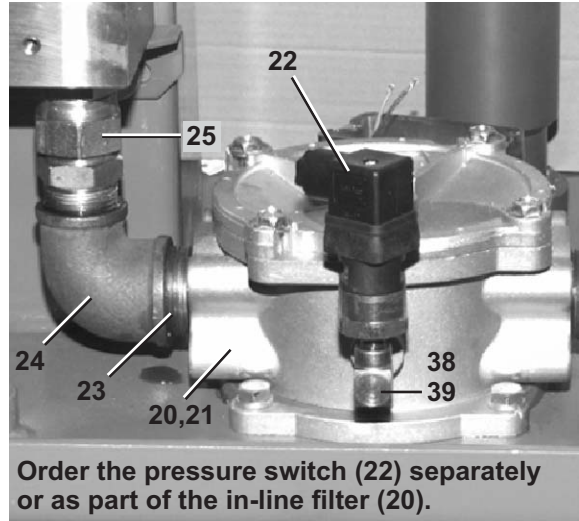

Hydraulic Tank

MP1A50

BMP110044/2012052A
(3 / 6)



Pellerin Milnor Corporation
P. O. Box 400, Kenner, LA 70063-0400

Litho in U.S.A.

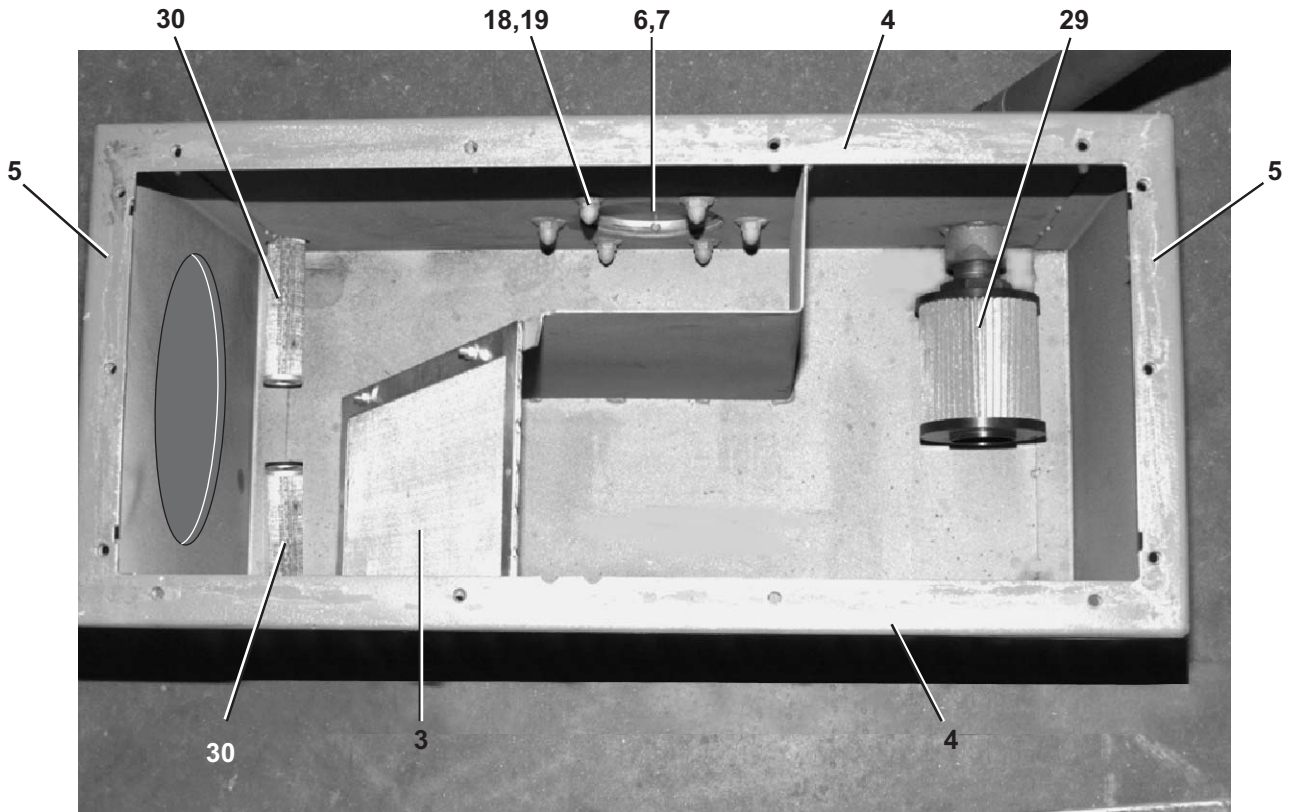
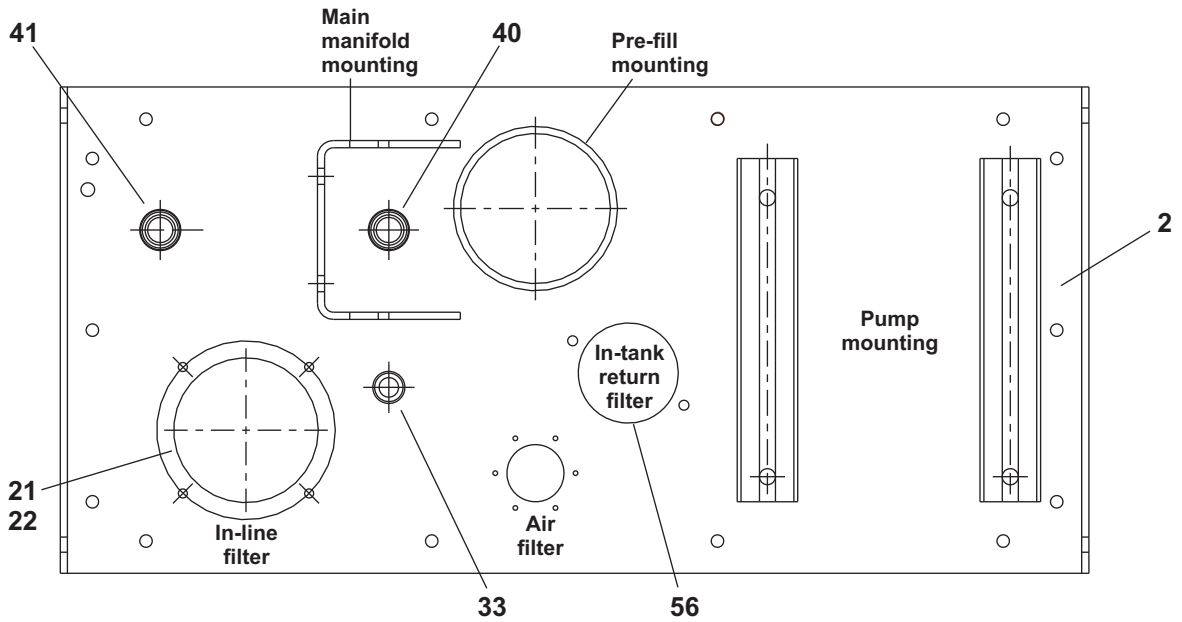

Hydraulic Tank

MP1A50

BMP110044/2012052A
(4 / 6)



Pellerin Milnor Corporation
P. O. Box 400, Kenner, LA 70063-0400

Litho in U.S.A.

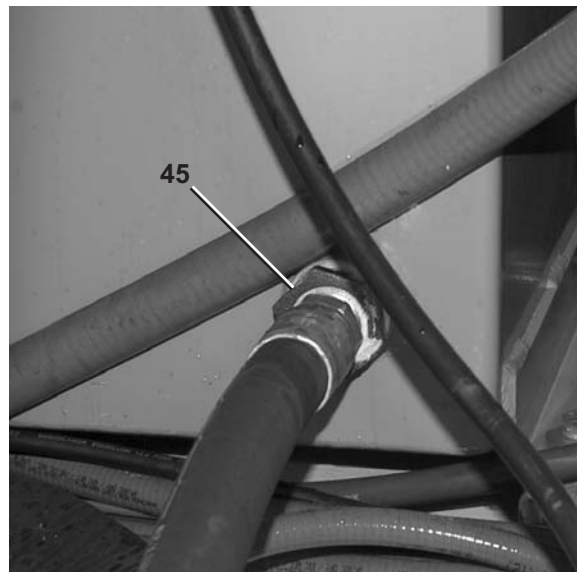
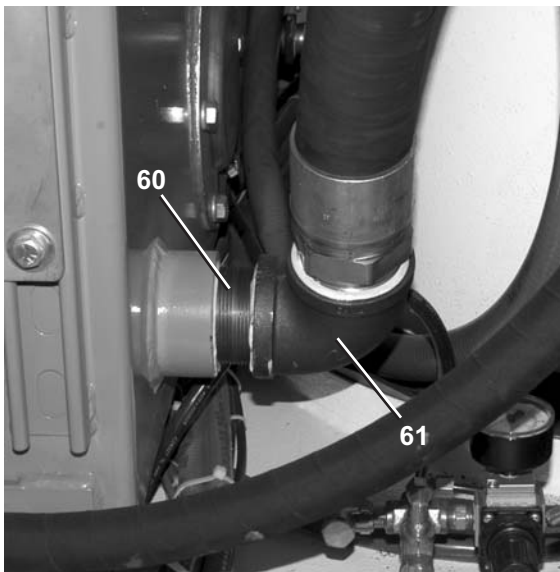
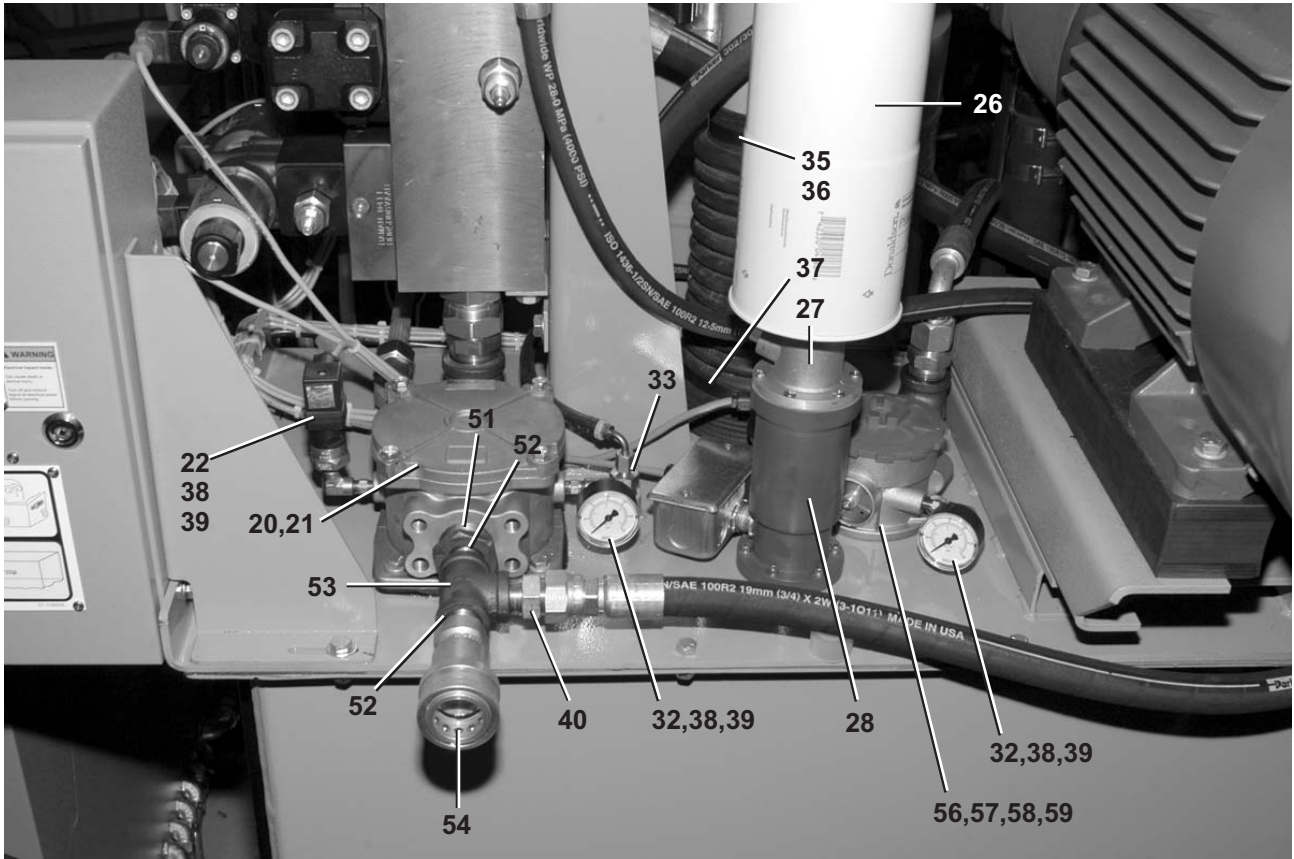



Pellerin Milnor Corporation
P. O. Box 400, Kenner, LA 70063-0400

Litho in U.S.A.

Parts List, Hydraulic tank

Find the correct assembly first, then find the needed components. The item letters (A, B, C, etc.) assigned to assemblies are referred to in the "Used In" column to identify which components belong to an assembly. The item numbers (1, 2, 3, etc.) assigned to components relate the parts list to the illustration.

Used In	Item	Part Number	Description	Comments
-----ASSEMBLIES-----				
	A	AHT10035A	OIL RESERVOIR MP1A50-50BAR	MP1A50
	B	AHT10046	HYDRAULIC TANK-MP1AXX	
-----COMPONENTS-----				
all	1	W7 10610	HYD OIL TANK WLMT-MP1A50	
all	2	W7 10562	OIL RESERVOIR TOP WLMT-MP1A03	
all	3	W7 60256	*COMB AIR SCREEN WLMT 5840GAS	
all	4	07 10530	HYDTANK TOP GASKET-LONG SIDE	
all	5	07 10530A	HYDTANK TOP GASKET-SHORT SIDE	
all	6	02 18618	COVER=BEARHOUSE	
all	7	02 18105A	HYD TANK COVER GASKET	
all	8	02 02366C	DOORGLASS GASKET 11"OD-NITRILE BLK	
all	9	02 09021	RING=DOOR GLASS PRESSURE	
all	10	02 09215	DRGLASS 12 3/8DIA SS STAMPED	
all	11	X7 10311A	GLASS SPACER-SSPRESS HYDTANK	
all	12	07 10244	DOOR GLASS COVER ANGLE	
all	13	07 10245	DOOR GLASS COVER	
all	14	07 10556	JUNCTION BOX BRKT	
all	15	15K095	HXCPSCR 3/8-16UNC2AX1 GR5 ZINC	
all	16	15U240	FLATWASHER(USS STD) 3/8" ZNC P	
all	17	15G205	HXNUT 3/8-16UNC2B ZINC GR2	
all	18	15K145	HXCAPSCR 1/2-13UNC2AX3/4 GR5 P	
all	19	15U300	LOKWASHER REGULAR 1/2 ZINC PLT	
all	20	27E7106	IN-LINE RETURN FILTER	
all	21	27E7106B	FILTER ELEMENT-STAUFF 25MIC	
all	22	27E7106C	EPS-1 - SWITCH=27E7106 STAUFF	
all	23	5N1ECLSF42	NPT NIP 1.25XCLS TBE BLKSTLS40	
all	24	5SL1EMFA	NPTELB 90DEG 1.25 BLKMAL 150#	
all	25	52ZC1ES001	TUBEFITMALESW 1+1/4"#20F650X-S	
all	26	27E7104D	AIR FILTER LHA#SPE60-25	
all	27	27E7202	AIR FILTER ADAPTER	



Pellerin Milnor Corporation
P. O. Box 400, Kenner, LA 70063-0400

Litho in U.S.A.

Parts List, Hydraulic tank cont.

Find the correct assembly first, then find the needed components. The item letters (A, B, C, etc.) assigned to assemblies are referred to in the "Used In" column to identify which components belong to an assembly. The item numbers (1, 2, 3, etc.) assigned to components relate the parts list to the illustration.

Used In	Item	Part Number	Description	Comments
all	28	27E7200	TEMPLEVEL/FILLER INDICATOR-KIP	
all	29	27E7108	SUCTION STRAINER 2" PORT	
all	30	27E7111	SUCT.STRAINER=EZYFLO#S-15-100	
all	31	27E7303	LEVEL INDICATOR W/THERM-STAUFF	
all	32	30N101	PRESSGAUGE 1/8"BACKCN.0-60PSI	
all	33	52AY0ER009	STR.1/4"MJICX1/2MP#2404-4-8	
all	34	5N0P22AF41	NPT NIP 3/4X22 TOE BLKSTL SK40	
all	35	60E025	4.5"/5.75" X 12"LG.#45A450575	
all	36	27A086	HOSECLAMP 3+1/8-6"CADSCR#HS-88	
all	37	27A087	HOSECLAMP 4+1/16-5"CADSCR#HS72	
all	38	52JY0CR001	ELBOW 1/8"FEM.#5504-02-02	
all	39	52LY0CR001	HEXPIP NIP 1/8"XCLOSE#5404-2-2	
all	40	52ZC0PS001	TUBEFITSTR3/4"#12-FLO-S	
all	41	52ZJ00S007	TUBEFIT90ELFCSL3/4"#12CLO-S	
all	42	5N1ACLSF42	NPT NIP 1X CLS TBE BLKSTL SK40	
all	43	5SL1AMFA	NPT ELBOW 90DEG 1" BLKMAL 150#	
all	44	96D084	BALL VALVE BRZ 1"BONOMI 171N	
all	45	5SB1A0PFEO	NPTHEXBUSH 1X3/4 BLKSTL 125#	
all	46	52XY0BP00Y	3/4"QUICK DISCONN.MALE#H6-63	
all	49	5N1K12AF42	NPT NIP 1.5X12 TBE BLKSTL SK40	
all	50	5SL1KMFK	NPT ELBOW 45DEG 1.5" BLK 1	
all	51	5SB1E0PMFO	NPTHEXBUSH 1.25X3/4 BLKML 150#	
all	52	5N0PCLSF42	NPT NIP 3/4XCLS TBE BLKSTLSK40	
all	53	5S0PMFA	NPT TEE 3/4" BLKMAL 150#	
all	54	52XY0BP00X	3/4"QUICK DISCONN.FEM #H6-62	
all	56	27E7112	INTANK RETURN FILTER 1+1/4"	
all	57	27E7112A	FILTER GAUGE-DONALDSON#P171956	
all	58	27E7112B	FILTER ELEMENT-REPLACEMENT	
all	59	27E7112C	ELEC.INDICAT-DONALDSON#P171966	
all	60	5N2KCLSB42	NPTNIP 2.5XCLS TBE BLKSTL SK40	
all	61	5SL2KMFC	NPTELB 90DEG STR 2.5 BLKM150#	

Hydraulic Main Pump

MP1A50, (MP1540 before 08/2020), (MP1640, MP1650, MP1556, MP1656 before 11/2019)

Figure 1: Pump motor mounting

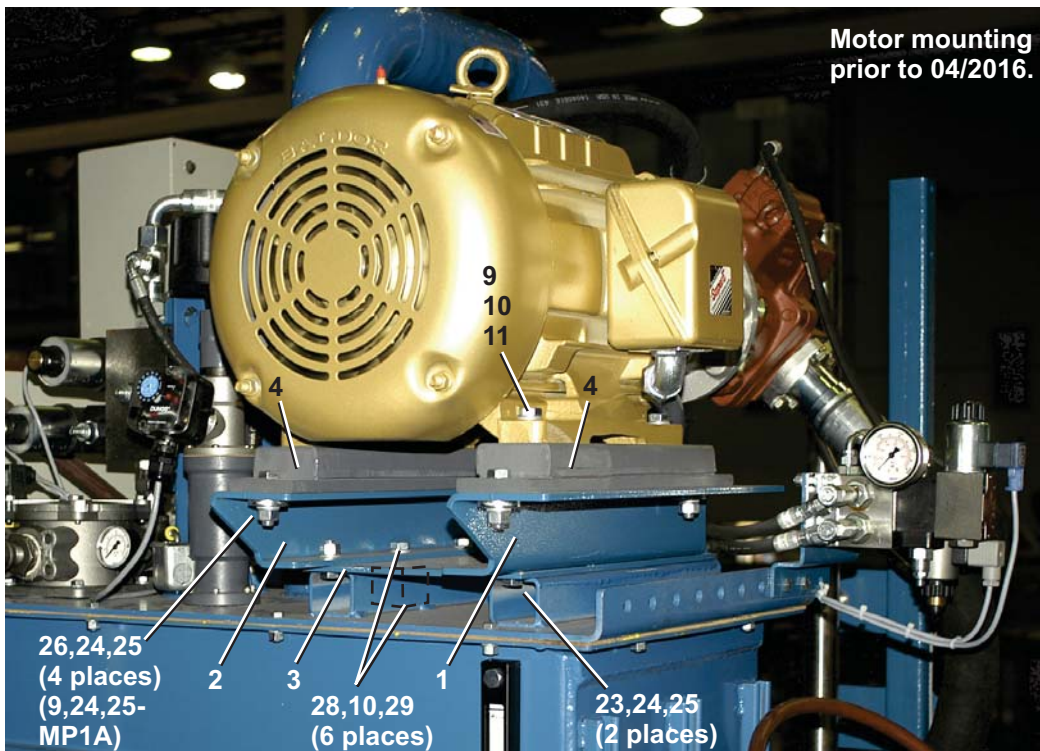
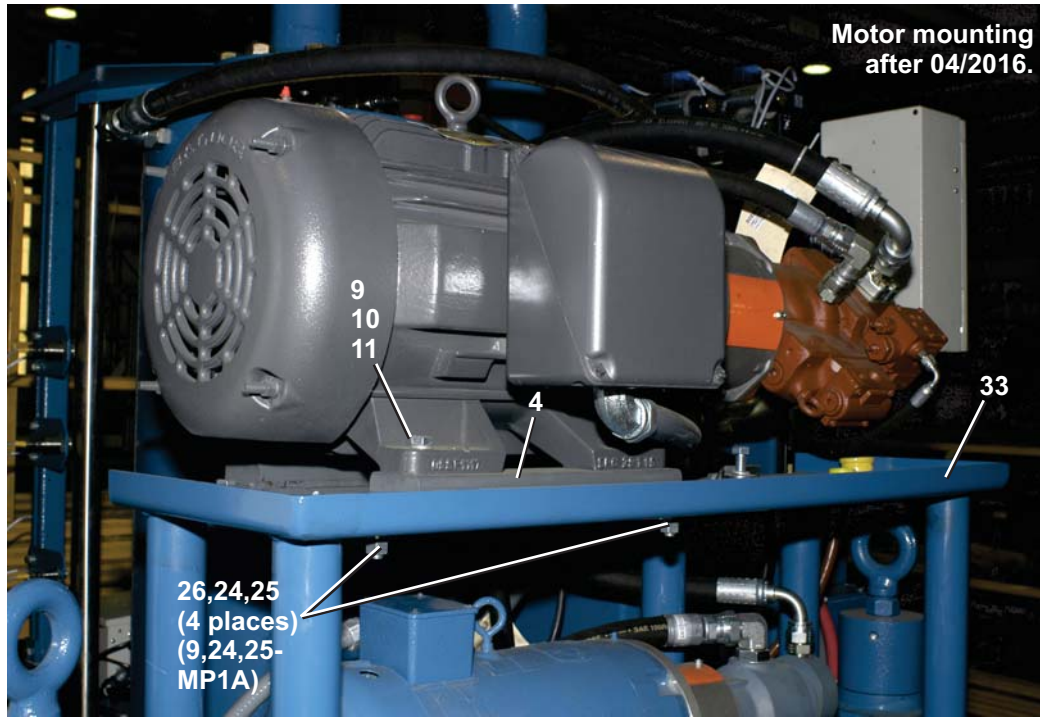

Hydraulic Main Pump

MP1A50, (MP1540 before 08/2020), (MP1640, MP1650, MP1556, MP1656 before 11/2019)

Figure 2: Pump mounting with Single Manifold after 04/2016

Pump Mounting 04/2016



20,21
31

Alternate Pump Mounting

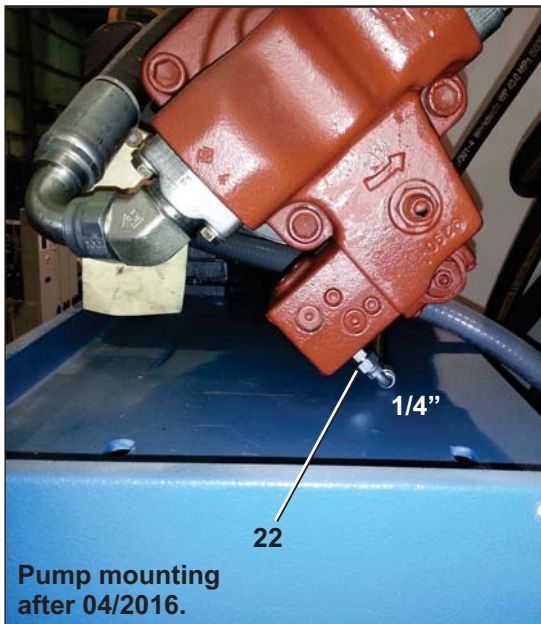
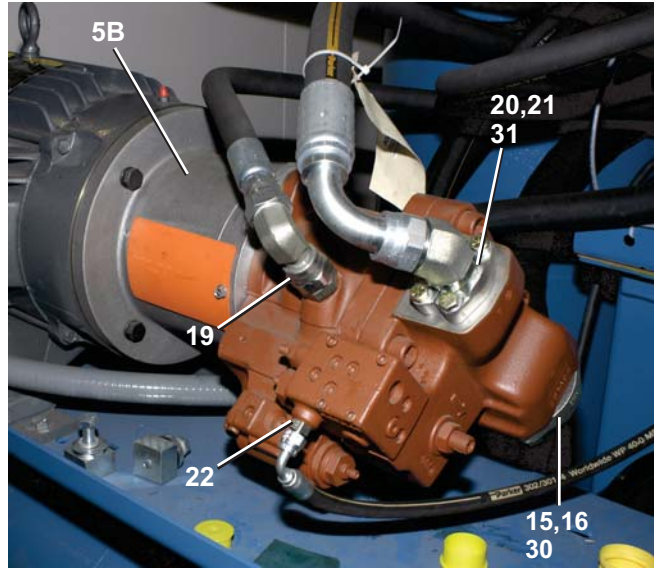

Pump mounting
after 04/2016.

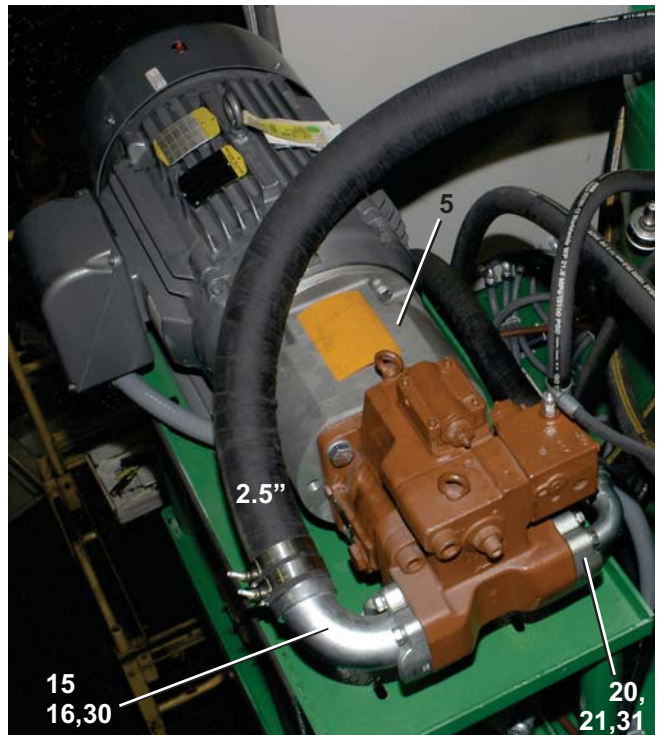

15
16,30

20,
21,31

MP1A50 with Single Manifold after 05/2017

Hydraulic Main Pump

MP1A50, (MP1540 before 08/2020), (MP1640, MP1650, MP1556, MP1656 before 11/2019)

Figure 3: Pump mounting prior to 04/2016

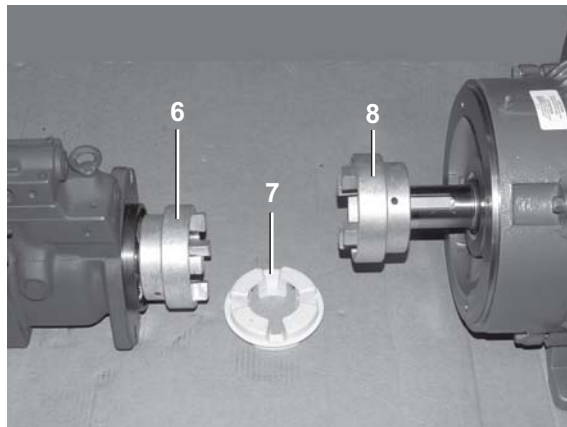
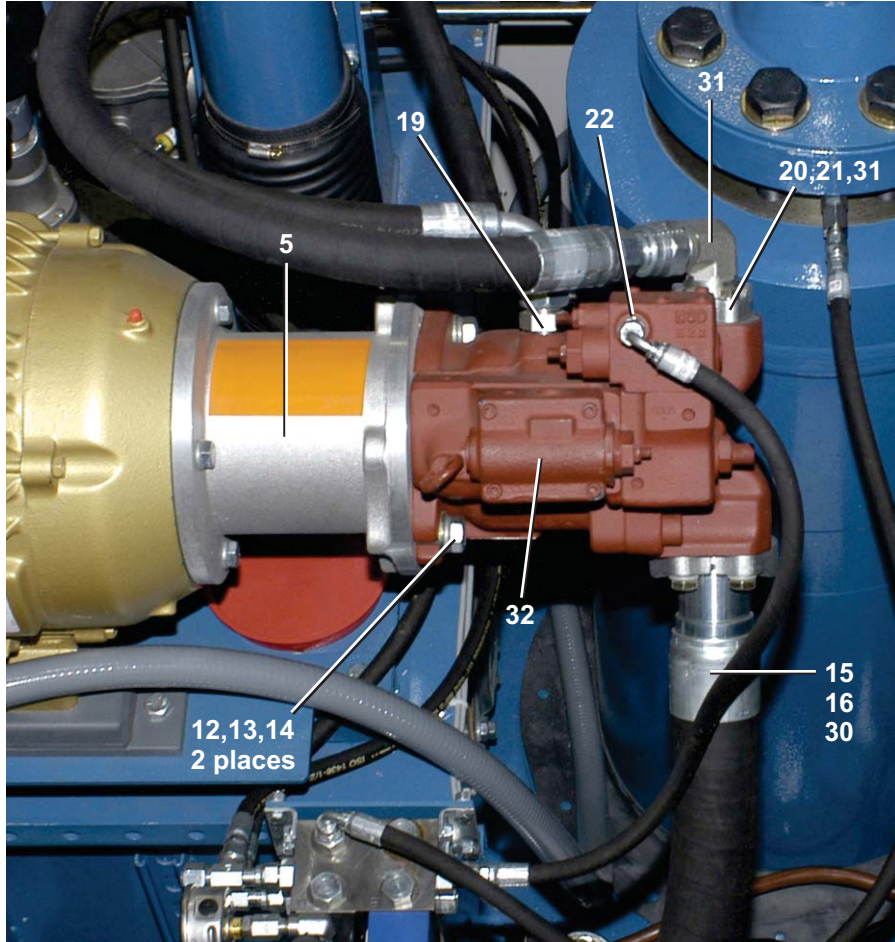

Coupling assembly

Hydraulic Main Pump

MP1A50, (MP1540 before 08/2020), (MP1640, MP1650, MP1556, MP1656 before 11/2019)

Parts List—Hydraulic Main Pump				
Find the correct assembly first, then find the needed components. The item letters (A, B, C, etc.) assigned to assemblies are referred to in the "Used In" column to identify which components belong to an assembly. The item numbers (1, 2, 3, etc.) assigned to components relate the parts list to the illustration.				
Used In	Item	Part Number	Description	Comments
-----REFERENCE ASSEMBLIES-----				
	A	GHC10022	MOTOR 254TC/80CC PUMP INSTL	(MP1540 before 8/2020, MP1640, 1556 before 11/2019)
	B	GHC10021	MOTOR 286TC/MAIN PUMP INSTL	(MP1650, 1656 before 11/2019)
	C	GHC10023	MOTOR 286TC/MAIN PUMP INSTL-40HP	MP1A50
	D	AHT10004D	HYD MAIN PUMP ASSY-35/50BAR	REFERENCE
	E	AHT10004E	HYD MAIN PUMP ASSY-MP1A03	REFERENCE
-----COMPONENTS-----				
all	1	07 10681	MOTOR MOUNT OUTSIDE 254/286	
all	2	07 10682	MOTOR MOUNT INSIDE 254/286	
all	3	07 10276	MOTOR MOUNT PLATE-47BAR	
all	4	60BS6841	DAMPENING ROD #HC-286TC-W (EACH = 1 BAR)	
A	5	27E5510C	PUMP-TO-MOTOR MOUNT 6.00"LG.	
B	5	27E5507JA	MAGNALOY M284682C ADAPTER	
C	5	27E5507A	PUMP-TO-MOTOR MOUNT 7.88"LG.	
A	6	27E5510	COUP.ASSY.=1+5/8"BOREX3/8KW	
BC	6	27E5507C	MAGNLOY COUP.M50012816 HUBONLY	
AB	7	27E5510B	HYTREL INSERT-MAGNA#M370H5	
C	7	27E5507D	MAGNALOY M570-U9 INSERT	
A	8	27E5510A	COUP.ASSY.=1+1/4"BOREX5/16KW	
B	8	27E5507J	MAGNALOY M50010810 HUB KEYED	
C	8	27E5507B	MAGNLOY COUP.M50012414 HUBONLY	
all	9	15K180	HXCAPSCR 1/2-13UNCAX2 GR5 ZINC	
all	10	15U300	LOKWASHER REGULAR 1/2 ZINC PLT	
all	11	15U241SZ	FLATWASHER 1.5 ODX.406 IDX.25T	
all	12	15K222A	HEXCAPSCR 5/8-11X3/4 GR8	
all	13	15U316	FLTWASH 5/8 HARD ASTM F436	
all	14	15U315	LOKWASHER MEDIUM 5/8 ZINCPL	
AB	15	27E5505C	SPLIT FLANGE-2"	
C	15	27E5507E	FLANGE ADAPT.KIT 2+1/2"CODE 61	
AB	16	27E5505D	O-RING FOR (27E5505C)	
C	16	27E5507ER	2+1/2"CODE61FLGORING-TOMKINS	
all	17	5SL2AMFA	NPT ELB 90DEG 2" BLKMAL 150#	
all	18	5N2ACLSB42	NPT NIP 2XCLS TBE BLKSTL SK40	
all	19	52ZCF50L0S	TUBEFITSTR3/4X1/2"#12-8F50LOS	
AB	20	27E5504B	PRESS.SPLITFLANGE FOR VAR.PUMP	
C	20	27E5507F	SPLIT FLANGE 1+1/4"CODE 62	
AB	21	27E5504BA	O-RING FOR (27E5504B)	

Hydraulic Main Pump

MP1540, MP1640, MP1565, MP1656, MP1A50

Parts List—Hydraulic Main Pump

Find the correct assembly first, then find the needed components. The item letters (A, B, C, etc.) assigned to assemblies are referred to in the "Used In" column to identify which components belong to an assembly. The item numbers (1, 2, 3, etc.) assigned to components relate the parts list to the illustration.

Used In	Item	Part Number	Description	Comments
all	23	15K151	HXCAPSCR 1/2-13UNC24X1.25 GR5	
all	25	15G230	HXNUT 1/2-13UNC2B SAE ZINC GR2	
all	26	15K173A	HXCAPSCR 1/2-13UNC2AX1.75 GR5	
all	28	15K182	HEXTAPSCR 1/2-13X2ZINC GR5 FUL	
all	29	02 19283	NUT=1/2-13UNCX1+1/2SQ SPEC	
C	30	51E098C	KINGCOMNIP 2.5"IDXNPT #ST30	
AB	31	52JY1AR011	EL90COD61FLGSEALOK1"#16LOEQ1-S	
C	31	52JY1ER002	EL90COD62FLGSLOK1.25"#20LOEQ2S	
A	32	27E550466	PISTON PUMP-KAWASAKI=35-BAR	35BAR
B	32	27E550566	PISTON PUMP-KAWASAKI(50BAR) K3VL 80/B	50BAR
C	32	27E550766	PISTON PUMP-KAWASAKI(110K)	110K
All	33	W7 10750	WLMT=PRESS WITH BOOSTER PUMP	

Booster Pump

MP1556,*MP1640, MP1656, MP1A50

WARNING: Incorrect adjustment of the booster pump can cause hydraulic pressure to rise to a hazardous level. This can result in injury and/or damage.

- Do not make careless or unauthorized pressure adjustments.

Ram Pressure Adjustment:

Adjust the relief valve nut until the ram pressure gage shows the correct pressure for the press model.

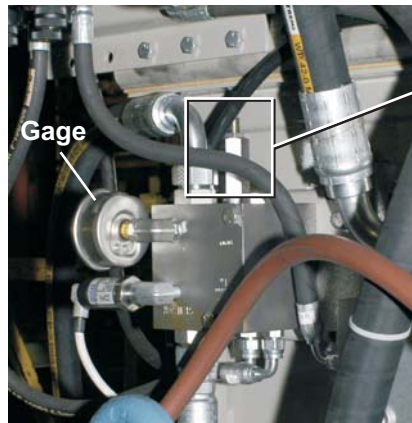

Booster pump relief valve

Booster Pump Manifold

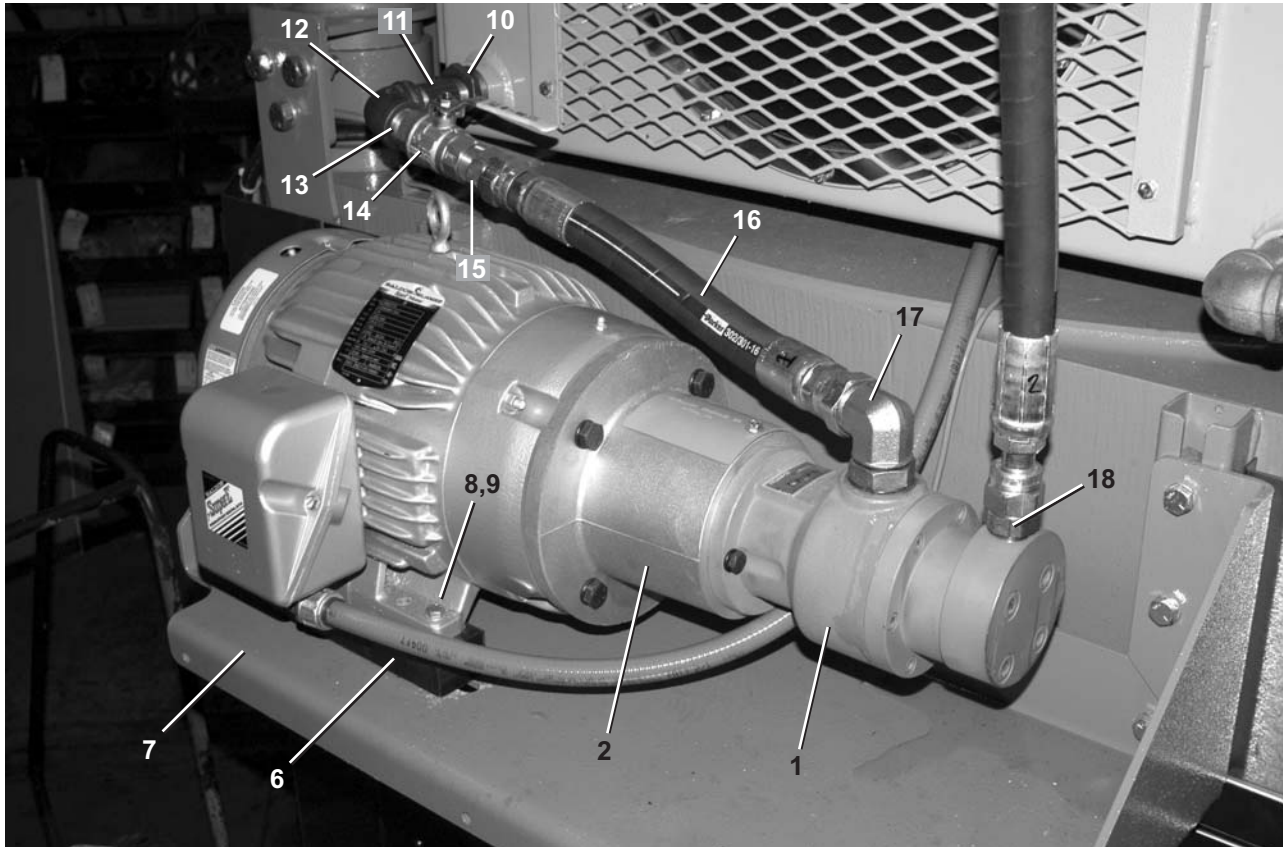

*=MP1640 with 13" ram

Booster Pump

MP1556,*MP1640, MP1656, MP1A50

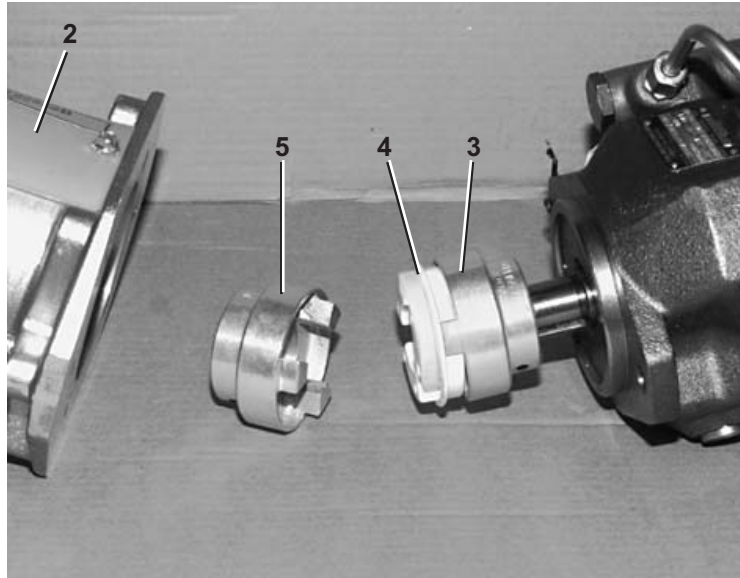

Parts List—Booster Pump

Find the correct assembly first, then find the needed components. The item letters (A, B, C, etc.) assigned to assemblies are referred to in the "Used In" column to identify which components belong to an assembly. The item numbers (1, 2, 3, etc.) assigned to components relate the parts list to the illustration.

Used In	Item	Part Number	Description	Comments
-----ASSEMBLIES-----				
	A	AHT10043	BOOSTER PUMP ASSEMBLY	
-----COMPONENTS-----				
all	1	27E55047	PUMP DYNEX #PF1005-10	
all	2	27E5513	PUMP-TO-MOTOR ADP MAGNALOY M182502A	
all	3	27E5513A	MAGNALOY M200 02808 COUPLING	
all	4	27E5513B	MAGNALOY M270U9 INSERT	
all	5	27E5505A	1+3/8"BORE W/5/16KW= CPLG.ASSY	
all	6	60BS6843	DAMPENING ROD #HC-215TC-W	
all	7	07 10596	BOOSTER PUMP BASE-SSPRESS	
all	8	15K096	HEXCAPSCR 3/8-16UNC2X1SS18-8	
all	9	15U260	LOCKWASHER MEDIUM 3/8 SS18-8	
all	10	5SB1K1ASFO	NPTHEXBUSH 1.5X1 304SS 150#	

Booster Pump

MP1556,*MP1640, MP1656, MP1A50

Parts List—Booster Pump

Find the correct assembly first, then find the needed components. The item letters (A, B, C, etc.) assigned to assemblies are referred to in the "Used In" column to identify which components belong to an assembly. The item numbers (1, 2, 3, etc.) assigned to components relate the parts list to the illustration.

Used In	Item	Part Number	Description	Comments
all	11	5N1A03KF42	NPT NIP 1X3.5 TBE BLK STL SK40	
all	12	5SL1AMFA	NPT ELBOW 90DEG 1" BLKMAL 150#	
all	13	5N1ACLSF42	NPT NIP 1X CLS TBE BLKSTL SK40	
all	14	96D084	BALL VALVE BRZ 1"BONOMI 171N	
all	15	52ZC0PS006	TUBEFITSTR 1MPTX16FS #16-16FLO-S	
all	16	60EH80C15A	ASSY=HYDRAULIC HOSE 1"X15"LG	
all	17	52ZJ00S008	TUBEFIT90EL 1"FCSLO#16C50L0-S	
all	18	52ZCF50L0S	TUBEFITSTR3/4X1/2"#12-8F50LOS	

Main Press Manifold

MP1540, MP1556, MP1640, MP1650, MP1656

BMP110024/2014373A
(1 / 4)



Pellerin Milnor Corporation
P. O. Box 400, Kenner, LA 70063-0400

Litho in U.S.A.

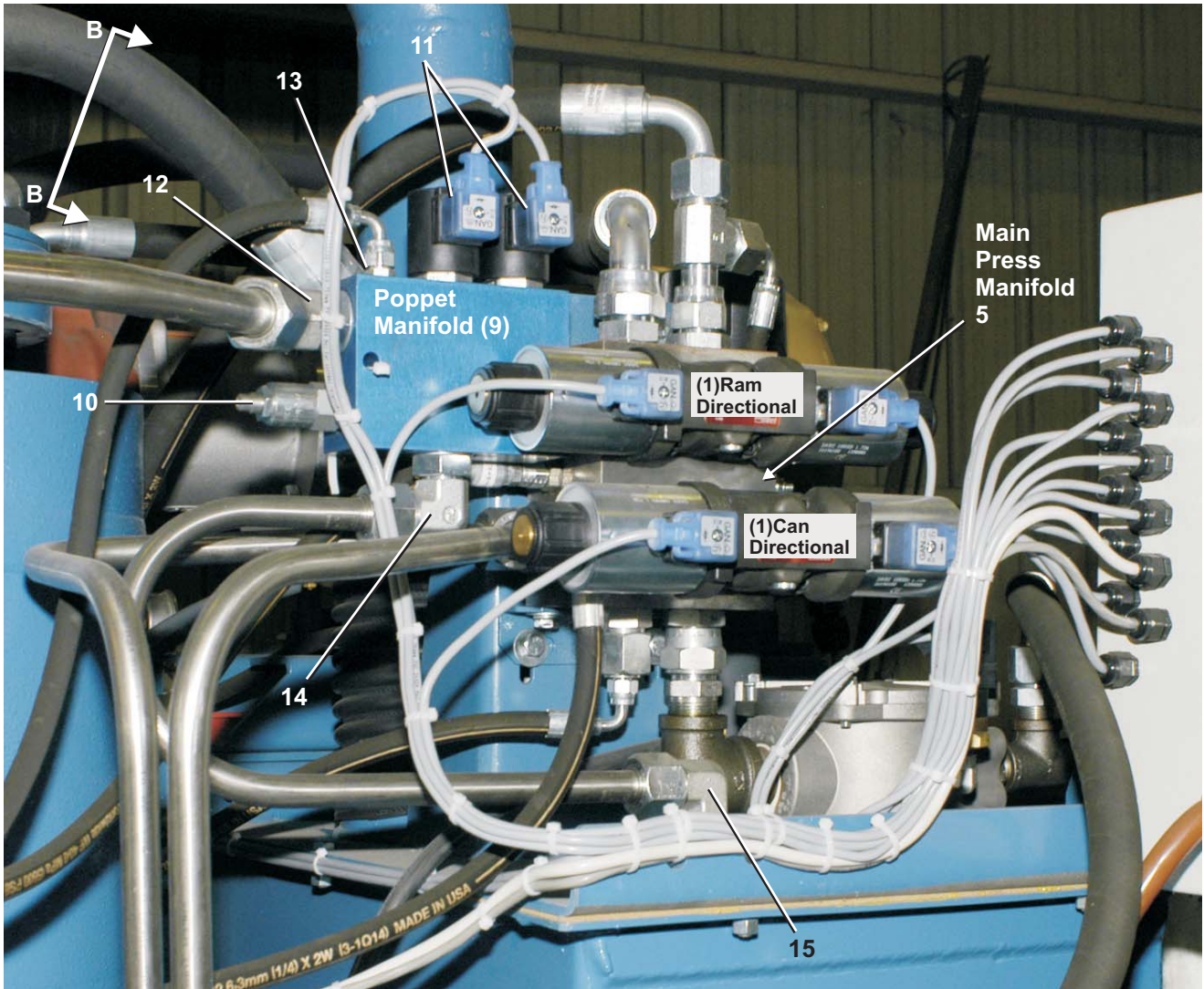

Main Press Manifold

MP1540, MP1556, MP1640, MP1650, MP1656

BMP110024/2014373A
(2 / 4)



Pellerin Milnor Corporation
P. O. Box 400, Kenner, LA 70063-0400

Litho in U.S.A.

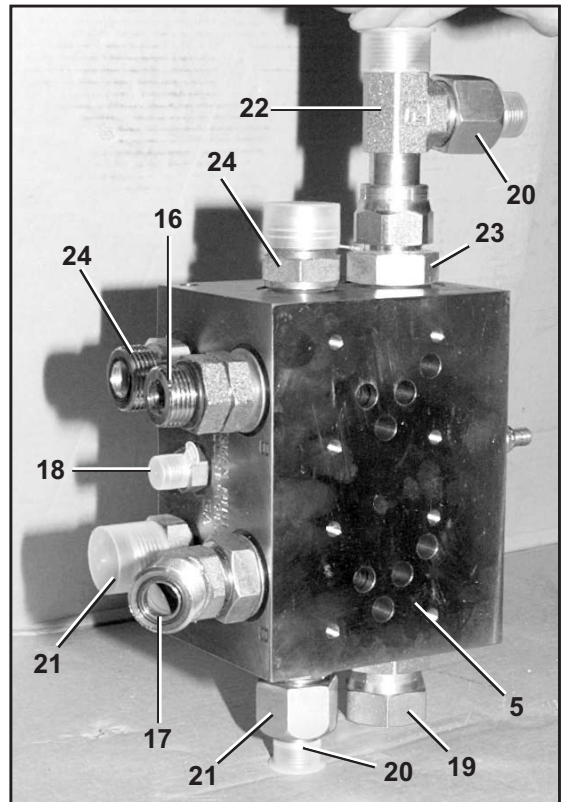
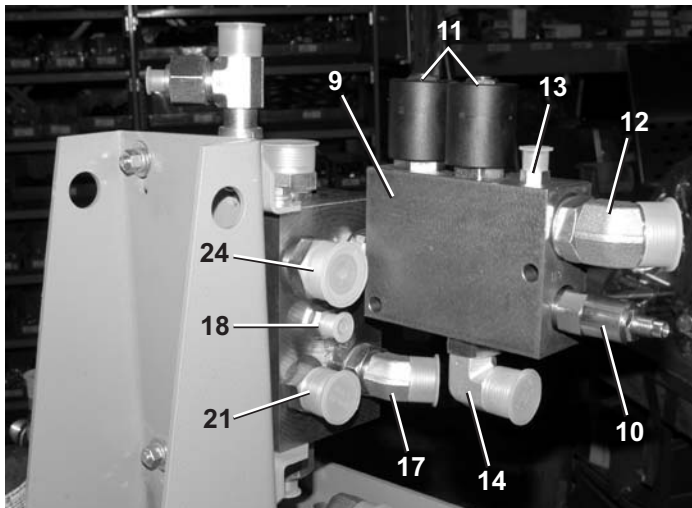
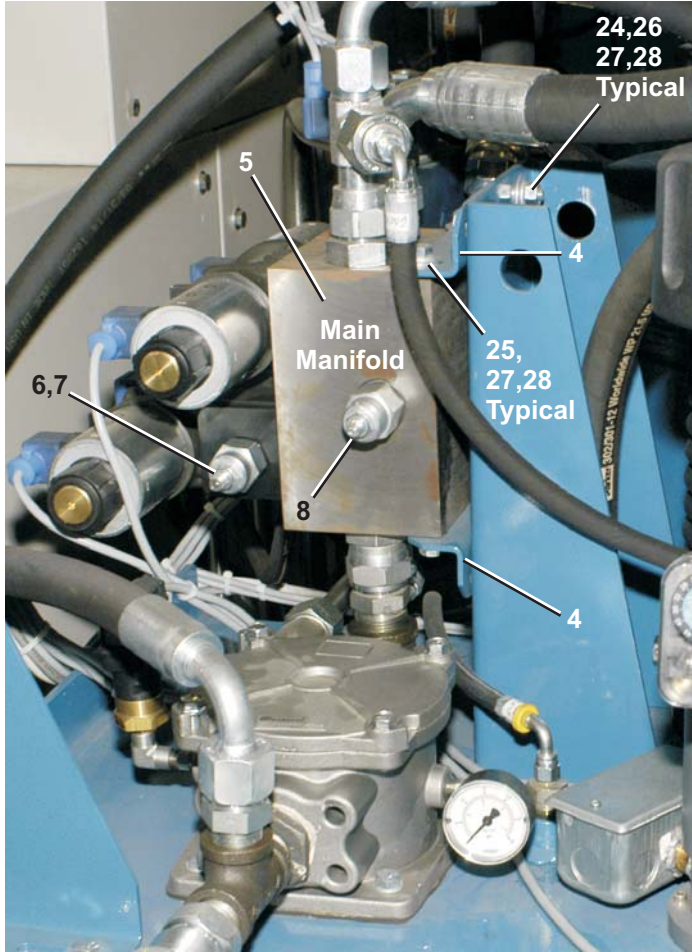

Main Press Manifold

MP1540, MP1556, MP1640, MP1650, MP1656

BMP110024/2014373A
(3 / 4)



Pellerin Milnor Corporation
P. O. Box 400, Kenner, LA 70063-0400

Litho in U.S.A.

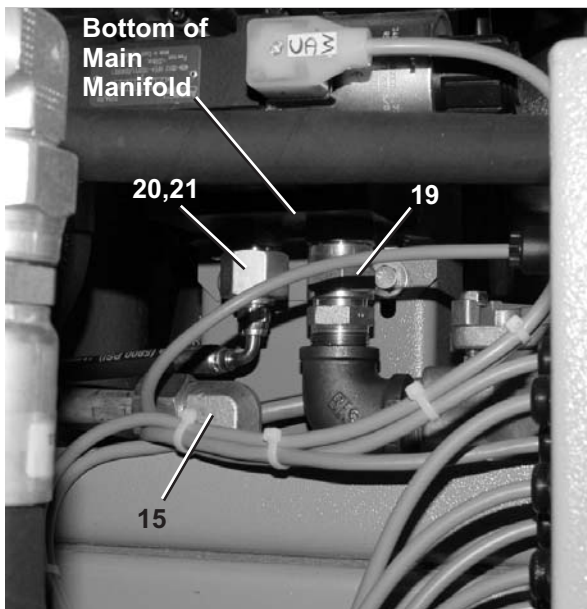
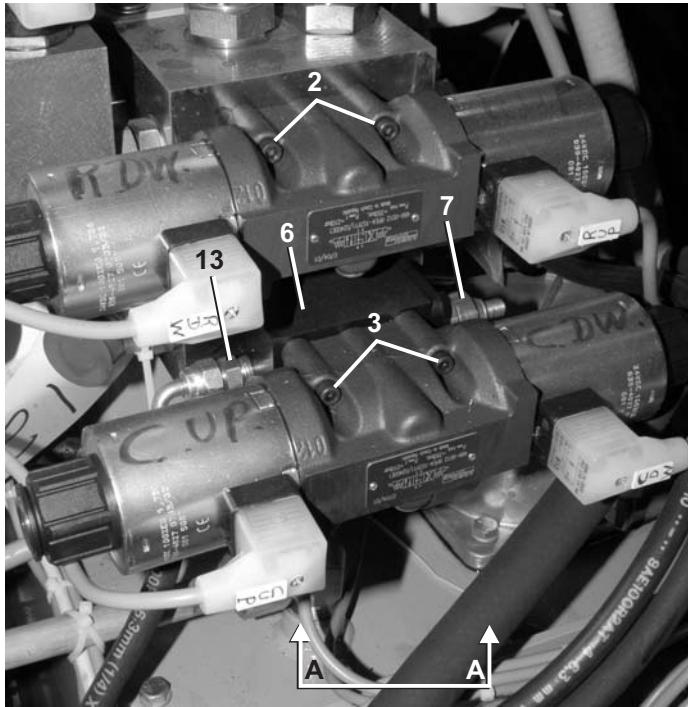

View A-A

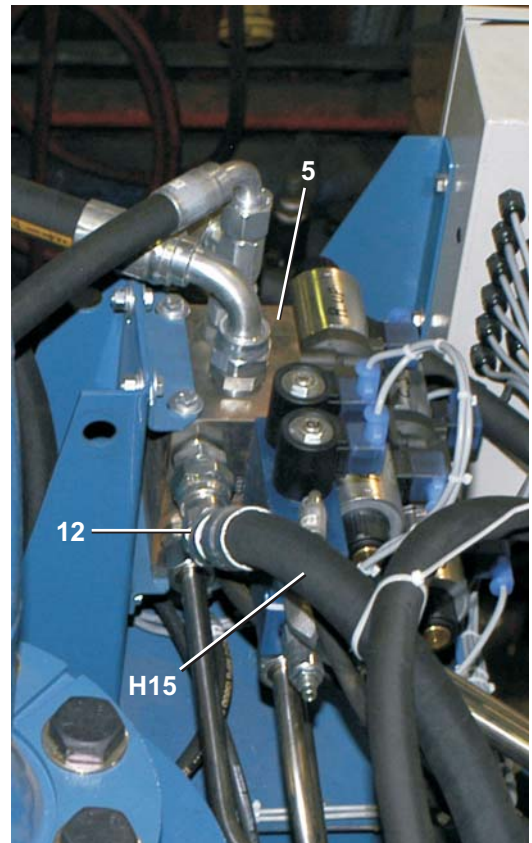

View B-B



Pellerin Milnor Corporation
P. O. Box 400, Kenner, LA 70063-0400

Litho in U.S.A.

Parts List—Main Press Manifold

Find the correct assembly first, then find the needed components. The item letters (A, B, C, etc.) assigned to assemblies are referred to in the "Used In" column to identify which components belong to an assembly. The item numbers (1, 2, 3, etc.) assigned to components relate the parts list to the illustration.

Used In	Item	Part Number	Description	Comments
			-----ASSEMBLIES-----	
	A	AHT10002D	MAIN PRESS MANIFOLD-35/50BAR	
			-----COMPONENTS-----	
all	1	96RH709E37	DIRECT.VALVE CENTER OP 24VDC	
all	2	15K045E	SKCPSCR 1/4-20X2 BLK	
all	3	15K049F	SOKCAPSCR 1/4-20X4 BLK GR8	
all	4	07 10241	PRESSURE MANIFOLD MTG ANGLE	
all	5	96DH453	MANIFOLD,DAMAN #DD05HP023S/S	
all	6	96DH475	PRESS.REDUCING VLV-SUN=BODY	
all	7	96DH475A	CARTRIDGE,PRESS.REDUCING VALVE	
all	8	96DH440A	CARTRIDGE,DIRECT RELIEF VALVE	
all	9	96DH452	MANIFOLD, MACH-V	
all	10	96DH499	RELIEF VAL HYDRAFORCE#RV10	
all	11	96DH452A01	POPPET=COIL + CARTRIDGE	
all	12	52ZJ1AS001	TUBEFIT45EL #16-12V50L0-S	
all	13	52AY0ER011	STRCONSEALOC 1/4"#4-F50LO-S	
all	14	52ZJ00S011	TUBEFIT90EL3/4"FACESEAL ORING	
all	15	52ZJ00S007	TUBEFIT90ELFC3/4"#12CLO-S	
all	16	52XY0KR052	STRADAPT 3/4"MOR #3474-12-12NW	
all	17	52ZJ00S005	TUBFITSTRTHD45ELFC#12V50L0-S	
all	18	52ZC0ES003	TUBEFITSTR1/4X3/8#4-6F50LO-S	
all	19	52XY1AP012	STRADAPT1"MORXFJS#6402-16-16-0	
all	20	52ZL00S006	TUBEFITENDRED3/4TX1/4T FACESL	
all	21	52ZC00S003	TUBEFIT STRTHDCN3/4"#12F5OLO-S	
all	22	52ZT00S001	TUBEFIT TEESWNUT 3/4"FACE SL OR	
all	23	52ZC00S004	TUBESTRCON3/4X1"OR#12-16F50L0S	
all	24	52ZC1AS006	TUBEFITSTR1X3/4#16-12F50LO-S	
all	25	15K065	HEXCAPSCR 5/16-18UNC2AX1 GR5 Z	
all	26	15G185	HXNUT 5/16-18UNC2B SAE ZINC GR	
all	27	15U200	FLATWASHER(USS STD) 5/16"ZNC P	
all	28	15U210	LOKWASHER MEDIUM 5/16 ZINCPL	

Main Press Manifold

MP1A50

BMP110078/2012055A
(1 / 4)



Pellerin Milnor Corporation
P. O. Box 400, Kenner, LA 70063-0400

Litho in U.S.A.

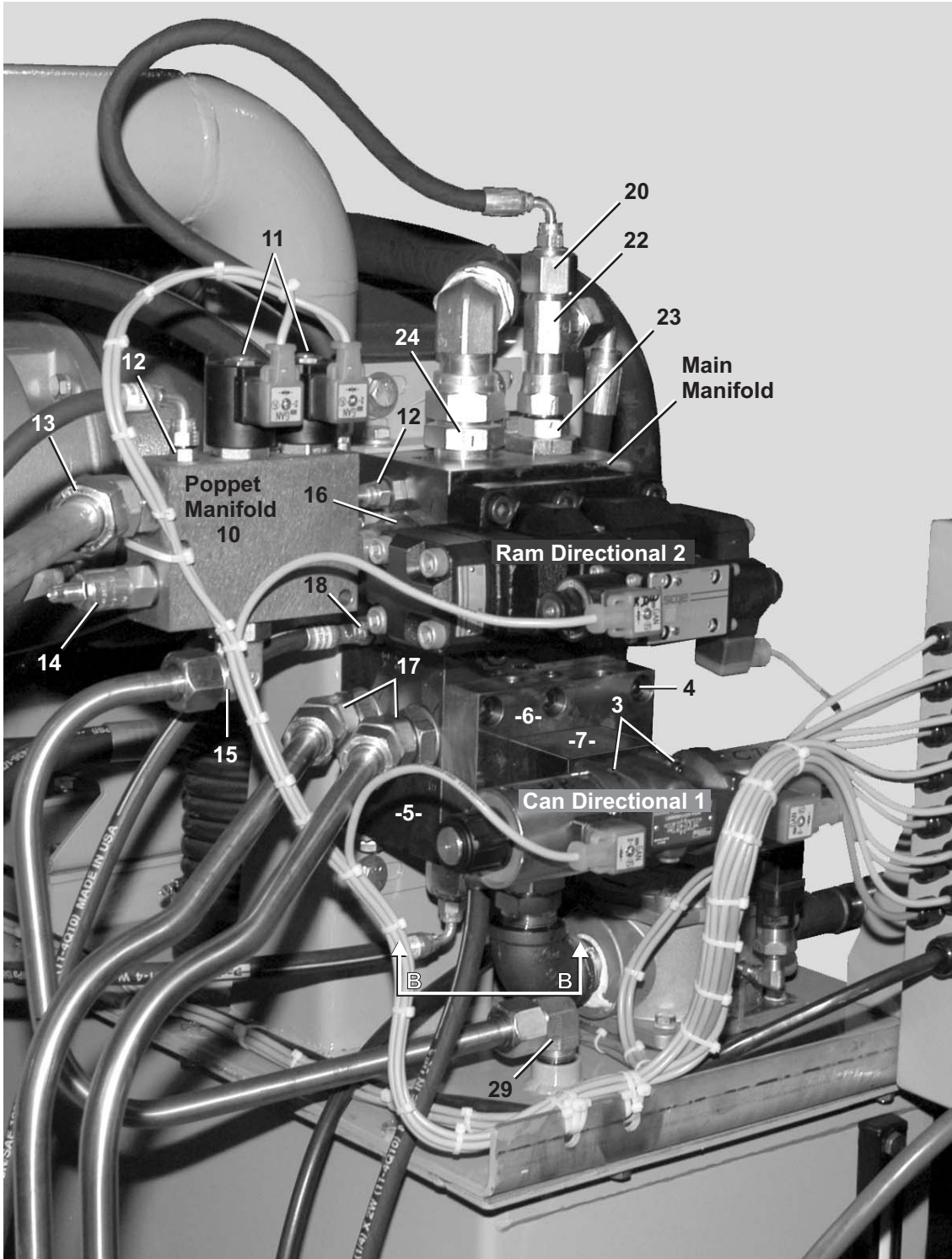

Main Press Manifold

MP1A50

BMP110078/2012055A
(2 / 4)



Pellerin Milnor Corporation
P. O. Box 400, Kenner, LA 70063-0400

Litho in U.S.A.

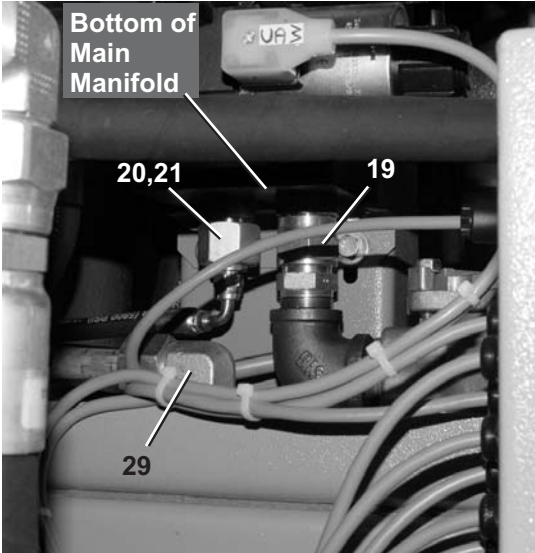
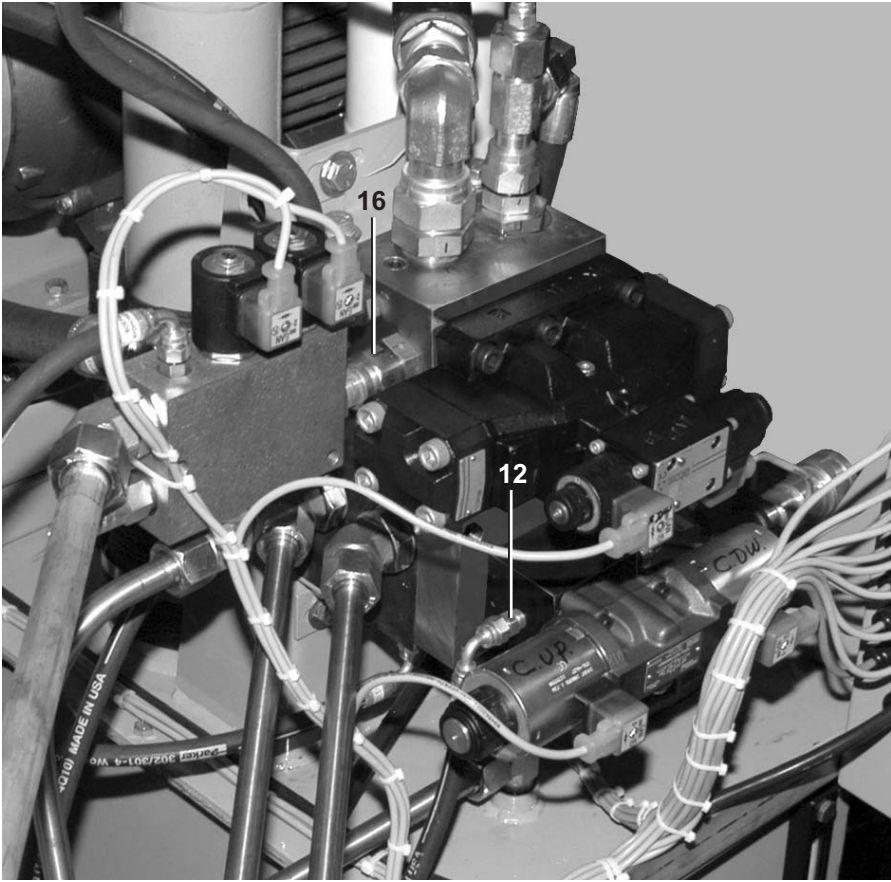

VIEW B-B

Main Press Manifold

MP1A50

BMP110078/2012055A
(3 / 4)



Pellerin Milnor Corporation
P. O. Box 400, Kenner, LA 70063-0400

Litho in U.S.A.

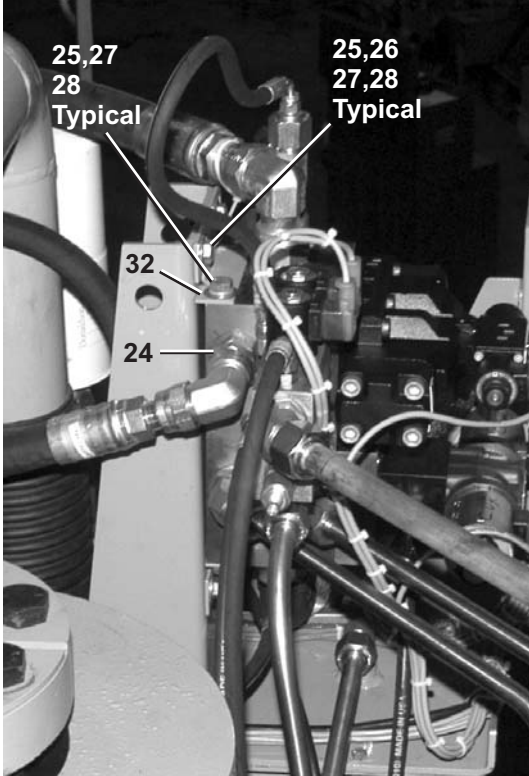
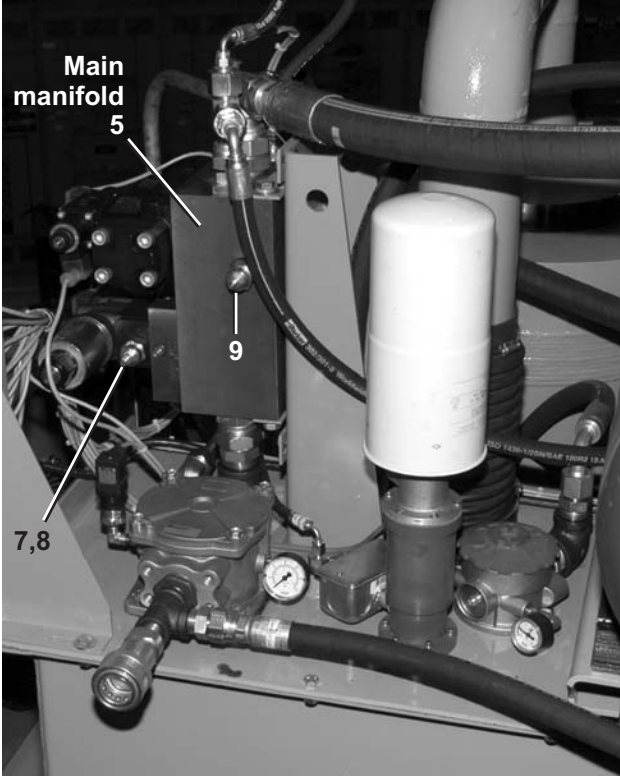

Main Press Manifold

BMP110078/2012055A
(4 / 4)



Pellerin Milnor Corporation
P. O. Box 400, Kenner, LA 70063-0400

Litho in U.S.A.

Parts List—Main Press Manifold

Find the correct assembly first, then find the needed components. The item letters (A, B, C, etc.) assigned to assemblies are referred to in the "Used In" column to identify which components belong to an assembly. The item numbers (1, 2, 3, etc.) assigned to components relate the parts list to the illustration.

Used In	Item	Part Number	Description	Comments
			-----ASSEMBLIES-----	
	A	AHT10002E	MAIN PRESS MANIFOLD-MP1A03	
			-----COMPONENTS-----	
all	1	96RH709E37	DIRECT.VALVE CENTER OP 24VDC	
all	2	96RH720	DIRECT.CONT.VLV.ATOS (D08)	
all	3	15K049F	SOKCAPSCR 1/4-20X4 BLK GR8	
all	4	15K121A	HXCPSC 3/8-16X2 GR8 ZC	
all	5	96DH485	MANIFOLD-DAMAN DD08P025S/S	
all	6	96DH485A	DAMAN ADAPTOR #DD05D08VAAB	
all	7	96DH475	PRESS.REDUCING VLV-SUN=BODY	
all	8	96DH475A	CARTRIDGE,PRESS.REDUCING VALVE	
all	9	96DH440A	CARTRIDGE,DIRECT RELIEF VALVE	
all	10	96DH452	MANIFOLD, MACH-V	
all	11	96DH452A01	POPPET=COIL + CARTRIDGE	
all	12	52AY0ER011	STRCONSEALOC 1/4"#4-F50LO-S	
all	13	52ZJ1AS001	TUBEFIT45EL #16-12V50L0-S	
all	14	96DH452A02	CARTRIDGE,RELIEF CARTRIDGE VLV	
all	15	52ZJ00S011	TUBEFIT90EL3/4"FACESEAL ORING	
all	16	52XY0KR052	STRADAPT 3/4"MOR #3474-12-12NW	
all	17	52ZJ0PS001	TUBEFIT45EL3/4"X1"#12-16V50L0S	
all	18	52ZC0ES003	TUBEFITSTR1/4X3/8#4-6F50LO-S	
all	19	52ZC1ES001	TUBEFITMALESW 1+1/4"#20F650X-S	
all	20	52ZL00S006	TUBEFITENDRED3/4TX1/4T FACESL	
all	21	52ZC00S003	TUBEFIT STRTHDCN3/4"#12F50LO-S	
all	22	52ZT00S001	TUBEFIT TEESWNUT 3/4"FACE SL OR	
all	23	52ZC00S004	TUBESTRCON3/4X1"OR#12-16F50L0S	
all	24	52ZC1AS006	TUBEFITSTR1X3/4#16-12F50LO-S	
all	25	15K065	HEXCAPSCR 5/16-18UNC2AX1 GR5 Z	
all	26	15G185	HXNUT 5/16-18UNC2B SAE ZINC GR	
all	27	15U200	FLATWASHER(USS STD) 5/16"ZNC P	
all	28	15U210	LOKWASHER MEDIUM 5/16 ZINCPL	
all	29	52ZJ00S007	TUBEFIT90ELFCSL3/4"#12CLO-S	

Manifolds and Valves used with Booster Pump

MP1556, MP1656, *MP1640, MP1A50

BMP110030/2023393A
(1 / 6)



Pellerin Milnor Corporation
P. O. Box 400, Kenner, LA 70063-0400

Litho in U.S.A.

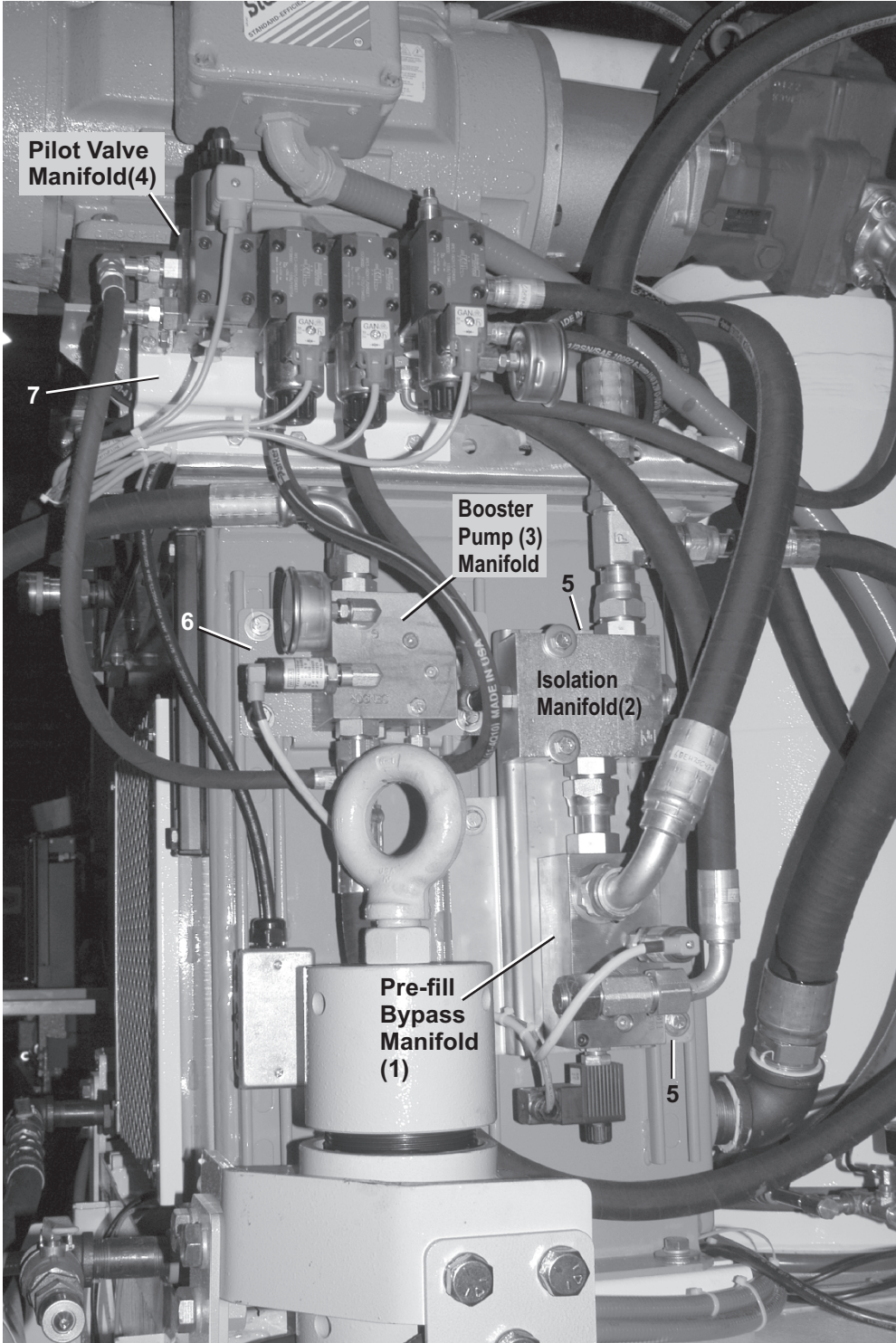

*=MP1640 with 13" ram

Manifolds and Valves used with Booster Pump

MP1556, MP1656, *MP1640, MP1A50

BMP110030/2023393A
(2 / 6)



Pellerin Milnor Corporation
P. O. Box 400, Kenner, LA 70063-0400

Litho in U.S.A.

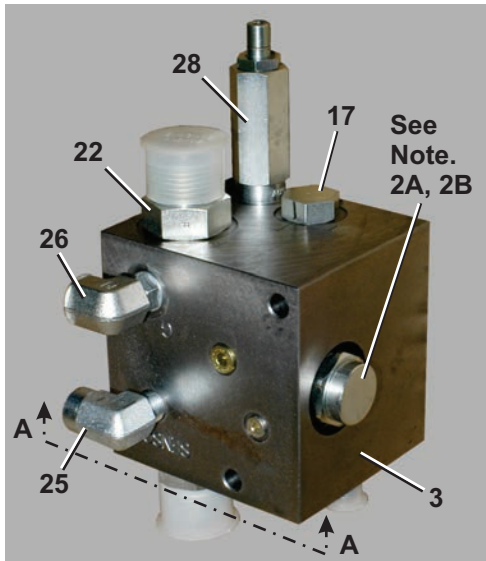

Booster Pump Manifold

Note: Booster Pump Manifold's check valve, used on presses produced prior 6/21/23, is obsolete. Check valve must be replaced with the larger check valve (comprised of items 2A & 2B) and the redesigned manifold (Item 3).

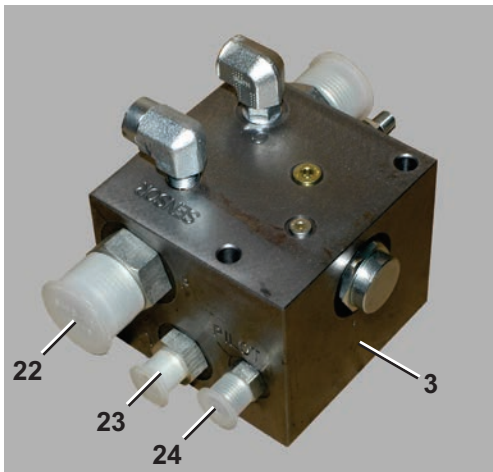

View A-A

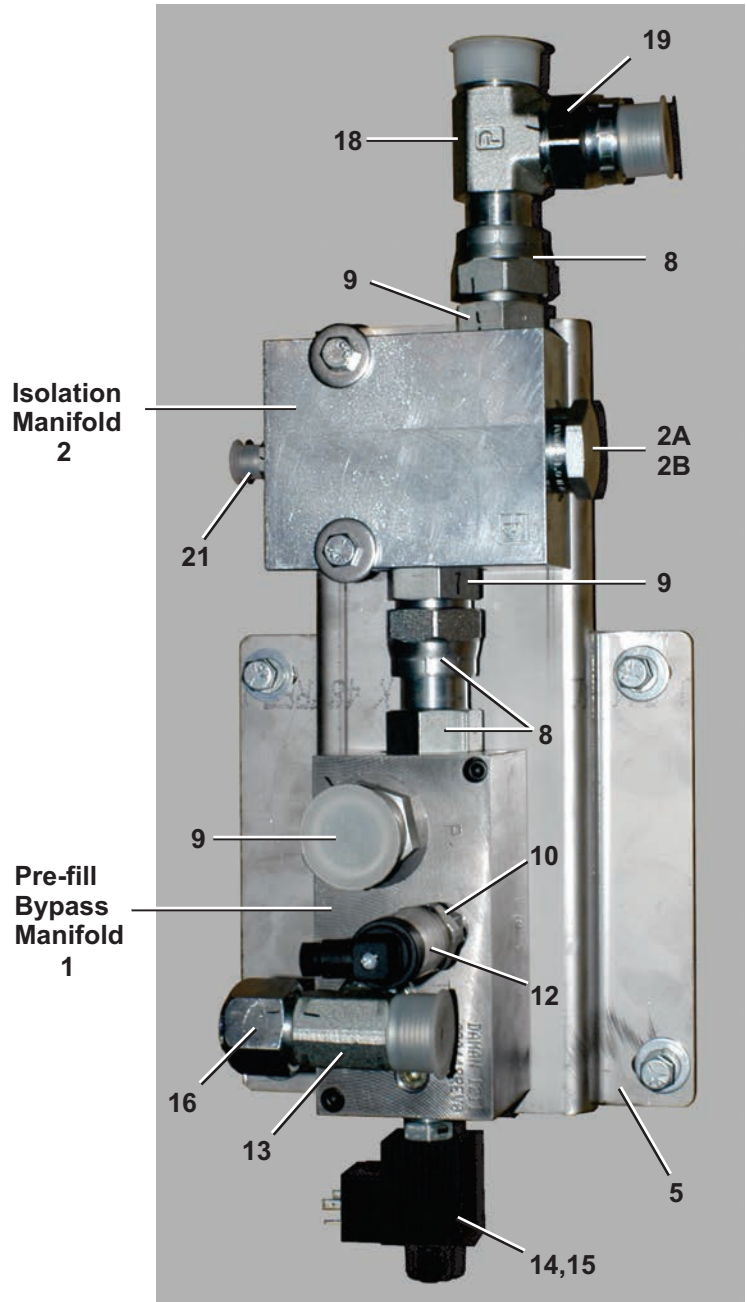

Isolation Manifold 2

Pre-fill Bypass Manifold 1

Manifolds and Valves used with Booster Pump

MP1556, MP1656, *MP1640, MP1A50

BMP110030/2023393A
(3 / 6)



Pellerin Milnor Corporation
P. O. Box 400, Kenner, LA 70063-0400

Litho in U.S.A.

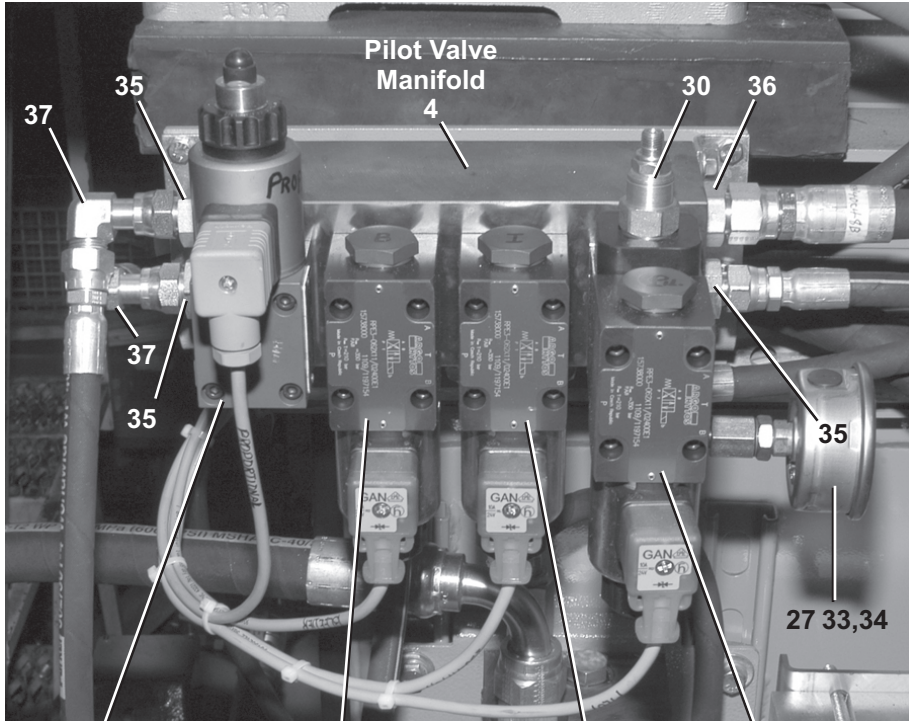

Proportional(32)
Pilot Valve

Bleeder(31)
Pilot Valve

Isolation(31)
Pilot Valve

Pre-fill(31)
Pilot Valve

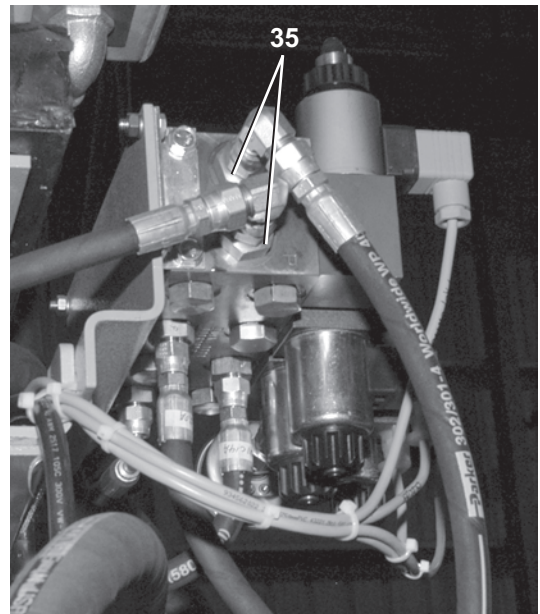
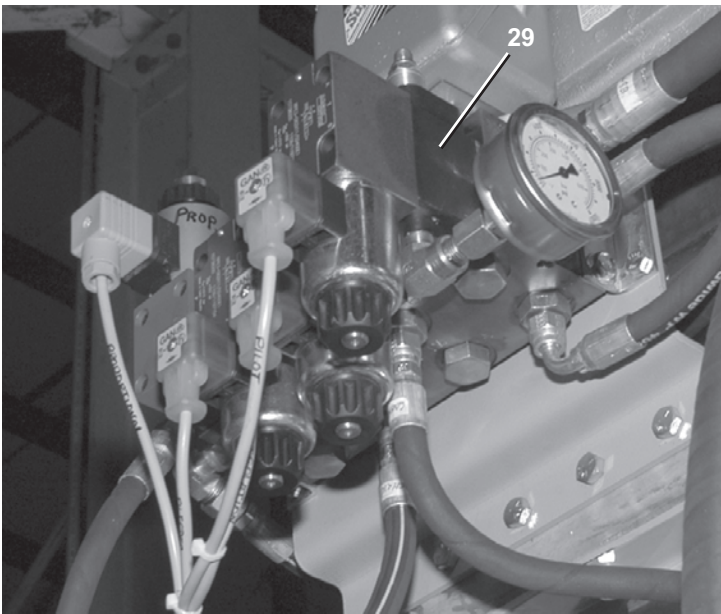

Manifolds and Valves used with Booster Pump

MP1556, MP1656, *MP1640, MP1A50

BMP110030/2023393A
(4 / 6)



Pellerin Milnor Corporation
P. O. Box 400, Kenner, LA 70063-0400

Litho in U.S.A.

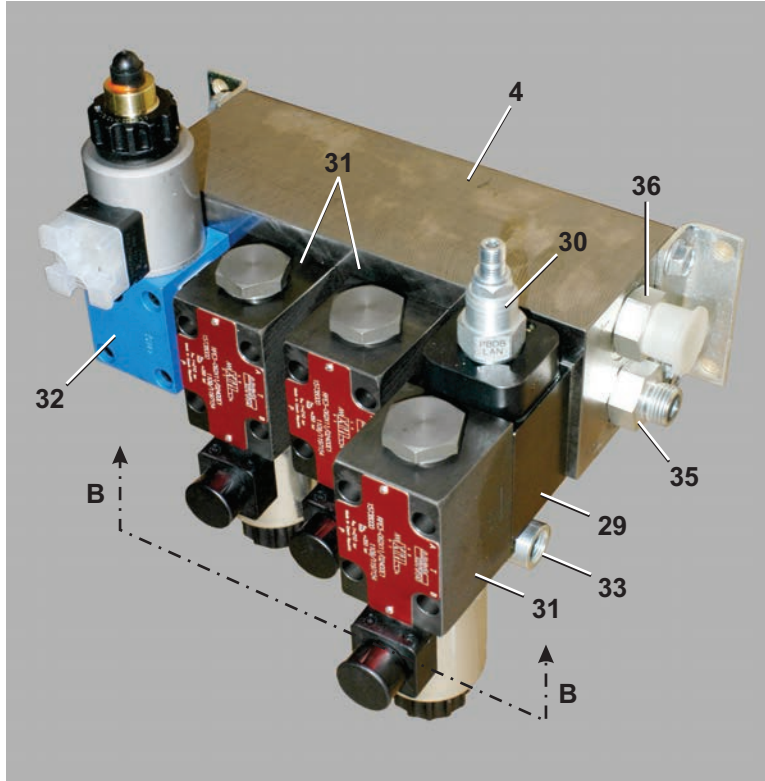

Pilot Valve Manifold



Orifice 1.0MM

38

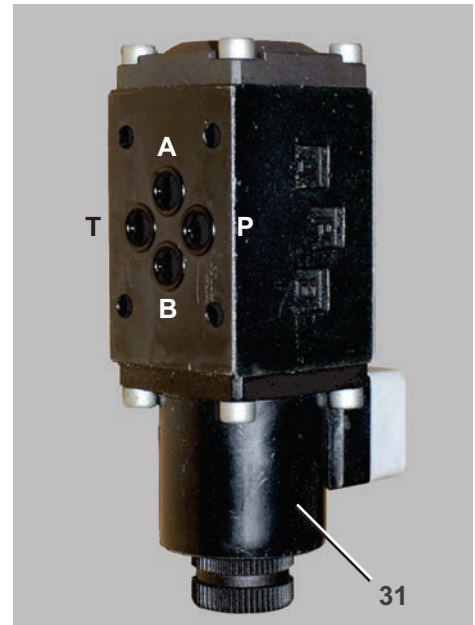

Directional Pilot Valves

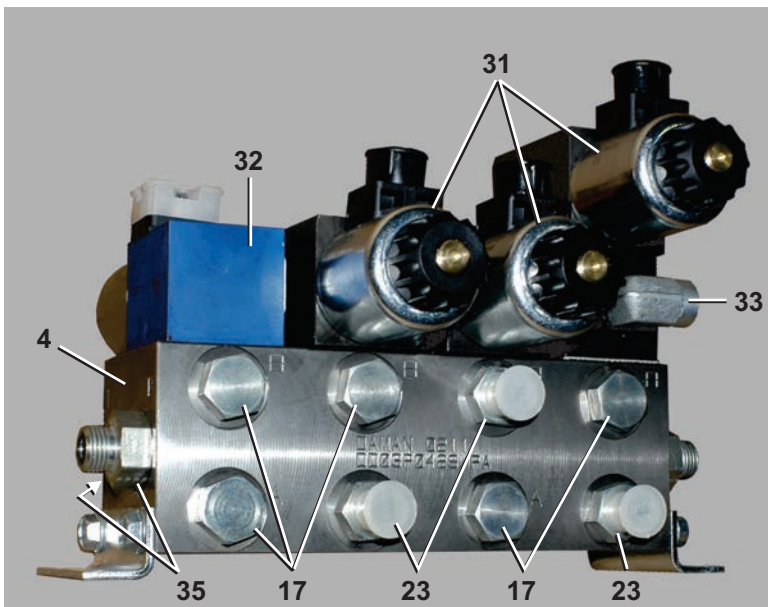

View B-B

Location of 1.0MM orifice (item 38)

Prefill pilot = port P
Isolation pilot = port B
Bleeder pilot = port A

MP1556, MP1656, *MP1640, MP1A50



Pellerin Milnor Corporation
P. O. Box 400, Kenner, LA 70063-0400

Litho in U.S.A.

Parts List—Manifolds and valves

Find the correct assembly first, then find the needed components. The item letters (A, B, C, etc.) assigned to assemblies are referred to in the "Used In" column to identify which components belong to an assembly. The item numbers (1, 2, 3, etc.) assigned to components relate the parts list to the illustration.

Used In	Item	Part Number	Description	Comments
-----ASSEMBLIES-----				
	A	AHT10010D	PREFILL VALVE MANIFOLD-MP1656	
	B	AHT10043	BOOSTER PUMP ASSEMBLY	
	C	AHT10047	BOOSTRUMP MANF-PILOT TO CLS ASSY	
	D	AHT10048	ISOLATION/BYPASS MANIFOLD ASSY	
-----COMPONENTS-----				
all	1	96RH713	DAMAN MANIFOLD C-30448	
all	2	96DH423B	CKVAL BLOCK PARKER#830687	
all	2A	96DH423	CKVAL CARTRIDGE STERLING	(2A+2B = Checkvalve)
all	2B	96DH423A	CKVAL PILOT PISTON PARKER STERLING	(2A+2B = Checkvalve)
all	3	96DH458B	C11453 W/ D06B2P1 VALVE & PILOT PISTON	After 6/21/23
all	4	96RH714	DAMAN MANIFOLD DD03P042SPA	
all	5	07 10622	ISOLATION/BYPASS BLOCKS BRKT	
all	6	07 10621	CHKVAL MANIFOLD MTG BKT-5"	
all	7	07 10620	MANIFOLD 4-STATIONS BRKT	
all	8	52ZC1AS001	TUBEFITSTRSW 1"#16-F650L-S	
all	9	52ZC00S008	TUBEFITSTRTHDCON 1"#16-F50L0	
all	10	52AY0ER015	STR.FORB-MP 1/4"#6404-04-04	
all	12	09N700B	TRANSDUCER WIKA C-10 0-5000 PSI	
all	13	52ZT0PS001	TUBEFITTEE 3/4" #12-S50L0-S	
all	14	96RH713A01	SUN CARTRIDGE#L0DA-8DN	
all	15	96RH713A02	SUN CART&COIL#DAAAMHN211	
all	16	52ZN0PS003	TUBEFIT NUT+CAP 3/4" 12 FNL-S	
all	17	52PY0KR001	HEXPLUG 1/2"OR #6408-08-0	
all	18	52ZT1AS003	TUBEFTTEE 1"PARKER#16R6L0-S	
all	19	52ZC1AS007	TUBEFITSTRED1"X3/4#16-12TRLO-S	
all	21	52ZC0ES003	TUBEFITSTR1/4X3/8#4-6F50LO-S	
all	22	52ZC00S003	TUBEFIT STRTHDCN3/4"#12F50LO-S	
all	23	52AY0ER010	STRTHDCNSLOC1/4X1/2"#4-8F50L0-S	
all	24	52AY0ER011	STRCONSEALOC 1/4"#4-F50LO-S	
all	25	52JY0ER008	ELBOW 90 #1/4 CD-S	
all	26	52JY0ER009	ELBOW90 #4A0EG5-S	

Manifolds and Valves used with Booster Pump

MP1556, MP1656, *MP1640, MP1A50

BMP110030/2023393A
(6 / 6)



Pellerin Milnor Corporation
P. O. Box 400, Kenner, LA 70063-0400

Litho in U.S.A.

Parts List, cont.

Find the correct assembly first, then find the needed components. The item letters (A, B, C, etc.) assigned to assemblies are referred to in the "Used In" column to identify which components belong to an assembly. The item numbers (1, 2, 3, etc.) assigned to components relate the parts list to the illustration.

Used In	Item	Part Number	Description	Comments
all	27	30N127W	WIKAGAGE 7/16-20SAE 10000PSI/B	
all	28	96DH450D	RELIEF VALVE STERLING #A04B2PZN	
all	29	96DH430B	BODY, SUN(STEEL) #EBP/S	
all	30	96DH430C	CARTRIDGE, SUN #PBDB-LAN	
all	31	96RH712A02	DIRECTIONAL PILOT VALVE+SOLENOID	
all	32	96RH708E38	PROP.RELIEF VALVE 6X DESIGN	
all	33	52JY0ER005	ELBOWPIPE 1/4 STR.#5502-4-4	
all	34	52AY0ER005	STR.1/4"FPX3/8"FJIC#6506-4-6	
all	35	52ZC00S010	TUBFITSTR 3/8X5/8 #6-10F50L0-S	
all	36	52ZC00S011	TUBESTRCON 1/2 X 5/8 #8-10 F5OLO-S	
all	37	52ZJ00S015	TUBEFIT 90EL 3/8"FCSEAL #6-C6LO-S	
all	38	96RH712A04	ORIFICE D1 1.0MM(.039) #15845600	

Pre-fill Pipe & Valve

MP1540, MP1556, MP1640, MP1656, MP1A50

BMP110025/2017222A
(1 / 3)



Pellerin Milnor Corporation
P. O. Box 400, Kenner, LA 70063-0400

Litho in U.S.A.

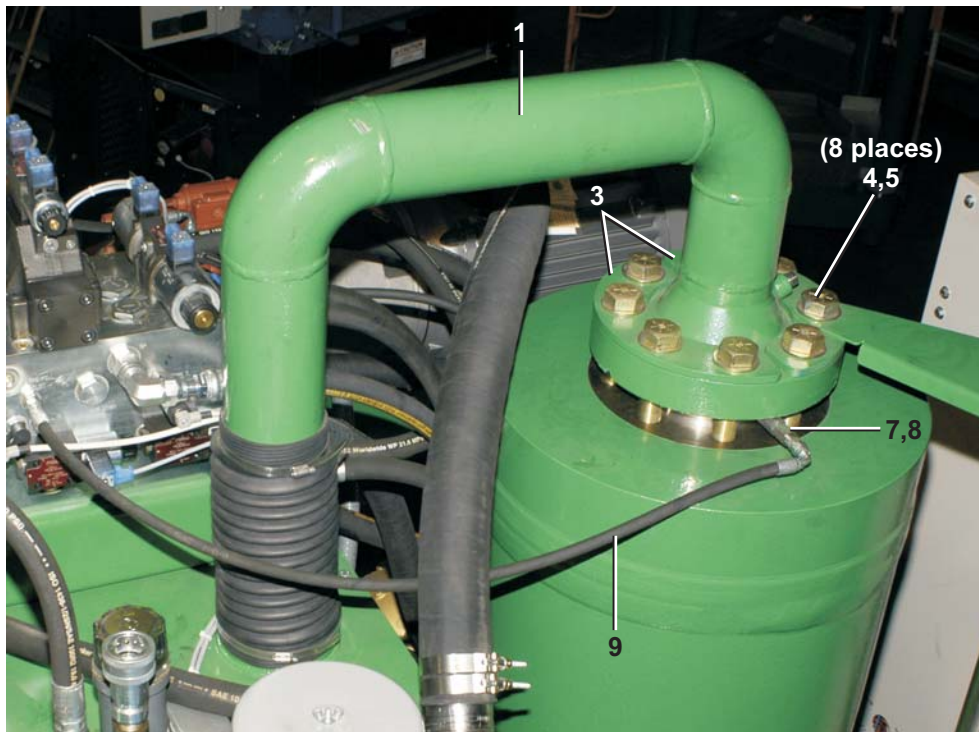
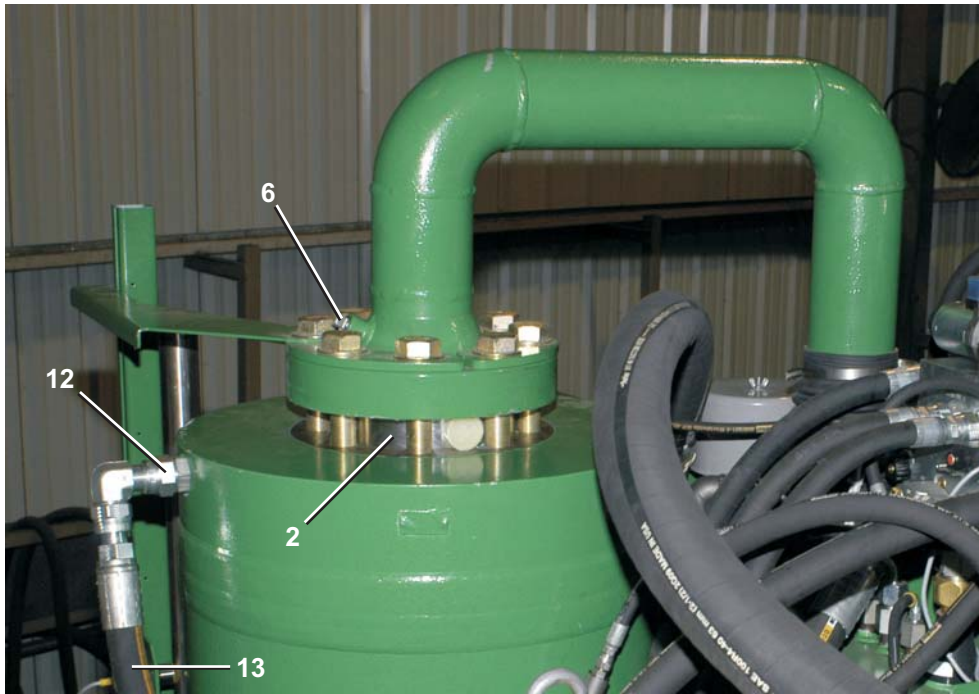

Pre-fill Pipe & Valve

MP1540, MP1556, MP1640, MP1656, MP1A50

BMP110025/2017222A
(2 / 3)



Pellerin Milnor Corporation
P. O. Box 400, Kenner, LA 70063-0400

Litho in U.S.A.

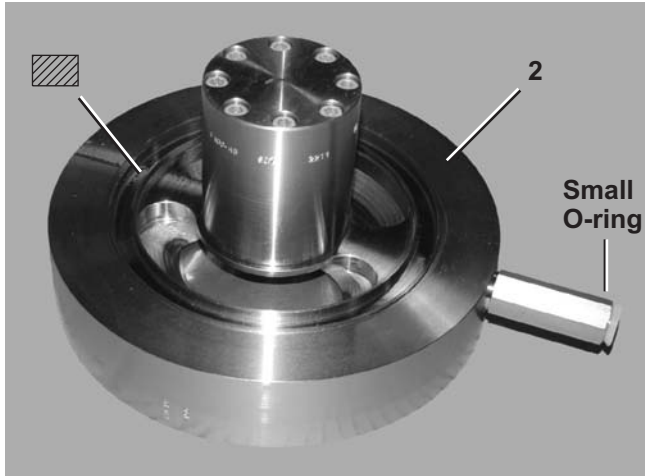

Prefill Valve

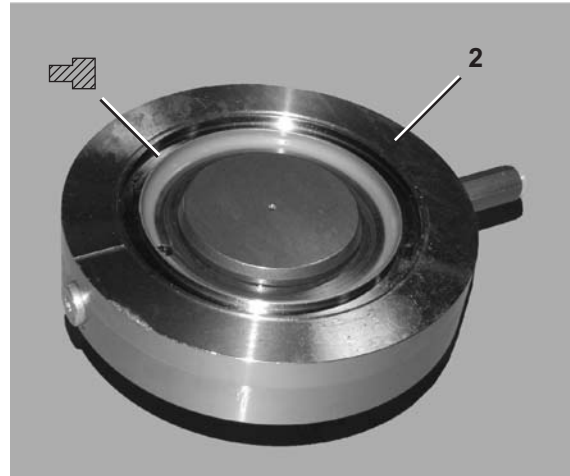

Bottom View: Prefill Valve

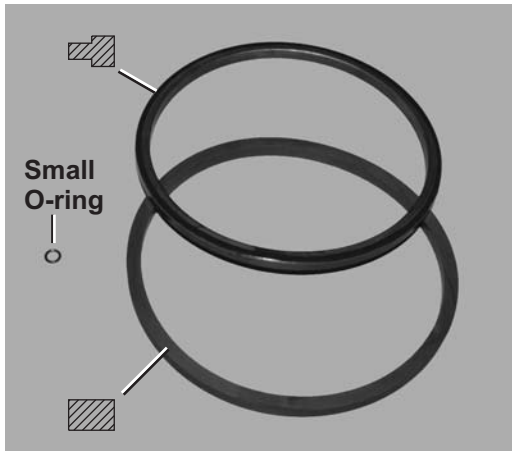

O-ring Kit for Prefill Valve (14)

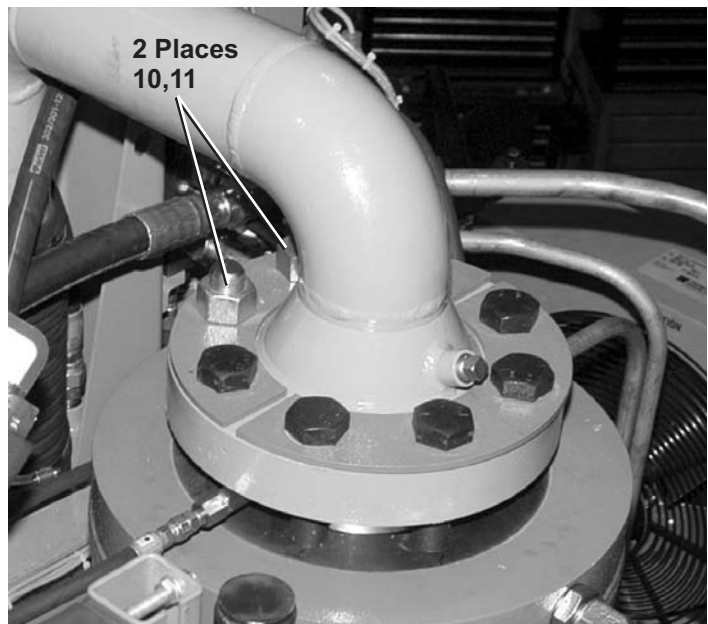

Detail: Hardware, Short Pre-fill Pipe (11.13")

Pre-fill Pipe & Valve

MP1540, MP1556, MP1640, MP1656, MP1A50

BMP110025/2017222A
(3 / 3)



Pellerin Milnor Corporation
P. O. Box 400, Kenner, LA 70063-0400

Litho in U.S.A.

Parts List—Pre-fill Pipe & Valve

Find the correct assembly first, then find the needed components. The item letters (A, B, C, etc.) assigned to assemblies are referred to in the "Used In" column to identify which components belong to an assembly. The item numbers (1, 2, 3, etc.) assigned to components relate the parts list to the illustration.

Used In	Item	Part Number	Description	Comments
-----ASSEMBLIES-----				
	A	AHT10010D	PREFILL VALVE MANIFOLD-MP1656	MP1556, *MP1640, MP1656
	B			MP1A50
	C	AHT10010B	PREFILL VALVE MANIFOLD	MP1540, MP1640
-----COMPONENTS-----				
AC	1	W7 10238	PREFILL PIPE 11.13 HT.WLMT	MP15_, MP16_
AC	1	W7 10238A	PREFILL PIPE 15.63 HT.WLMT	MP15_, MP16_
B	1	W7 10288	PREFILL PIPE 11.13 HT-MP1A03	MP1A50
B	1	W7 10288A	PREFILL PIPE 15.63 HT-MP1A03	MP1A50
all	2	96RH712F	PREFILL VALVE HAWE #F100-45	
all	3	X7 10267	PREFILL PIPE FLANGE WASHER	
all	4	15K307	HEXCAPSCR 1+1/8-12X5+1/2" GR8 BLK	
all	5	15U441	FLTWASH 1-1/8" HARD ASTM F436	
all	6	51P031	PLUG PIPE SQ 1/2-14 NPT HD PLA	
all	7	52AY0ER013	CONV.ADAPT.BRIT.1/4X1/4F40HG-S	
all	8	52ZC0ES001	TUBEFIT 1/4"STR.#4-4-FLO-S	
A,C	9	60EH21C42A	ASSY=HYDRAULIC HOSE 1/4 X42LG	MP1556, MP1656,*MP1640 SINGLE MANIFOLD
B	9	60EH21C40A	ASSY=HYD HOSE 1/4X48"LG	MP1A50 SINGLE MANIFOLD
all	10	17R113A07K	STUD 1 1/8-12UNFX7+1/2 B7 ZINC	PREFILL PIPE 11.13
all	11	15G258	HXNUT 1+1/8-12UNF2B ZINC GR2	PREFILL PIPE 11.13
all	12	52ZC00S008	TUBEFITSTRTHDCON 1"#16-F50L0	
A	13	60EH75C84A	ASSY=HYDRAULIC HOSE 1"X84"LG	MP15_, MP16_ SINGLE MANIFOLD
B	13	60EH75C76A	HHOSE 1"STRFEMORSWX90FEMORSW=76"	MP1A SINGLE MANIFOLD
all	14	96RH712FOR	ORING KIT FOR 96RH712F	
all	15	27E5516	HOSCLAMP HALVES 1"-H4 PARK#H6378HPP	
all	16	27E5518	CLAMP COVER PL 1"-H6 PARKER #CPH-6	
all	17	27E5523	HOSCLAMP LOCK PLATE #LP-3	
all	18	27E5524	HOSCLAMP SPEED NUT #CRA1-8	

Oil Cooler - Air Cooled

MP1540, MP1556, MP1640, MP1650, MP1656, MP1A50
 MPL556, MPL640, MPL650, MPL656

BMP110033/2021055A
 (1 / 2)



Pellerin Milnor Corporation
 P. O. Box 400, Kenner, LA 70063-0400

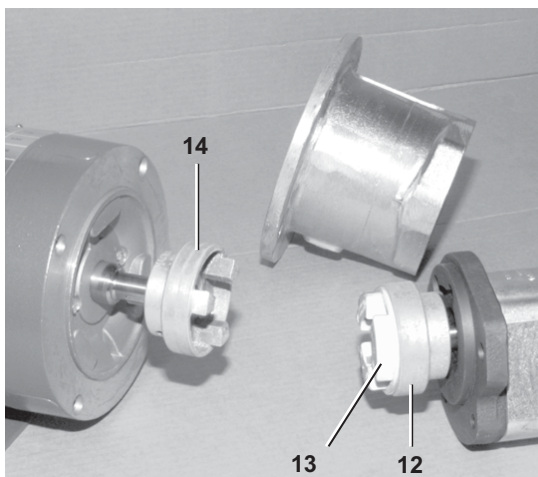

Cooler Pump Coupling Assembly

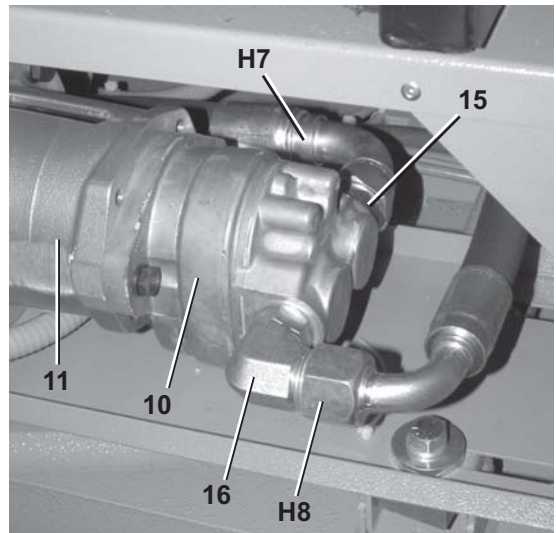

Oil Cooler - Air Cooled

**MP1540, MP1556, MP1640, MP1650, MP1656, MP1A50
MPL556, MPL640, MPL650, MPL656**

**BMP110033/2021055A
(2 / 2)**



Pellerin Milnor Corporation
P. O. Box 400, Kenner, LA 70063-0400

Litho in U.S.A.

Parts List—Oil Cooler - Air Cooled

Find the correct assembly first, then find the needed components. The item letters (A, B, C, etc.) assigned to assemblies are referred to in the "Used In" column to identify which components belong to an assembly. The item numbers (1, 2, 3, etc.) assigned to components relate the parts list to the illustration.

Used In	Item	Part Number	Description	Comments
-----ASSEMBLIES-----				
	A	G80CT001A	COOLING TOWER- 96DH462A & 96DH463	MP15X, MP16X MPL640,650 MPL556,656
	B	G80CT001B	COOLING TOWER ASSY-96DH464	MP1A50
-----COMPONENTS-----				
A	1	07 10308	RECIRC PUMP HOUSING-TOP	
B	1	07 10308B	RECIRC PUMP HOUSING-TOP	
A	2	07 10796	RECIRC HOUSING BOTTOM	
B	2	07 10798	RECIR HOUSING BOTTOM-MP1AXX	
all	3	15K095	HXCPSCR 3/8-16UNC2AX1 GR5 ZINC	
all	4	15G205	HXNUT 3/8-16UNC2B ZINC GR2	
all	5	15U255	LOCKWASHER MEDIUM 3/8 ZINCPL	
all	6	15U240	FLATWASHER(USS STD) 3/8" ZNC P	
all	7	15K085	HEXCAPSCR 3/8-16UNC2AX3/4 GR5	
all	8	52ZJ00S009	TUBEFIT90EL3/4X5/8"FACESEAL OR	
all	9	52ZC00S003	TUBEFIT STRTHDCN3/4"#12F5OLO-S	
all	10	27E5506	GEAR PUMP-RECIRC.PUMP-EATON	
all	11	27E5506A	PUMP TO MOTOR MOUNT	
all	12	27E5506G	COUP ASSY=5/8" BORE X 5/32" KW	
all	13	27E5506D	URETHANE INSERT FOR COUP.ASSY.	
all	14	27E5506B	COUP.ASSY=5/8"BORE X 3/16"KW	
all	15	52XY0KR050	STRDPT 3/4MX1"MJ#6400-16-12-0	
all	16	52ZJ00S007	TUBEFIT90ELFCSL3/4"#12CLO-S	
all	17	27HS091AAU	OIL COOLER 8HP@15GPM 50/60	
all	17	27HS092AAU	OIL COOLER 20HP@10GPM 50/60	
all	17	27HS091A98	OIL COOLER 8HP@15GPM 575V	
all	17	27HS092A98	OIL COOLER 20HP@10GPM 575V	
all	H7-H9		FOR HOSES, SEE BMP200015.	

Oil Cooler - Water Cooled

MP1540, MP1640, MP1556, MP1656, MP1A50
MPL550, MPL556, MPL640, MPL650, MPL656

Figure 1

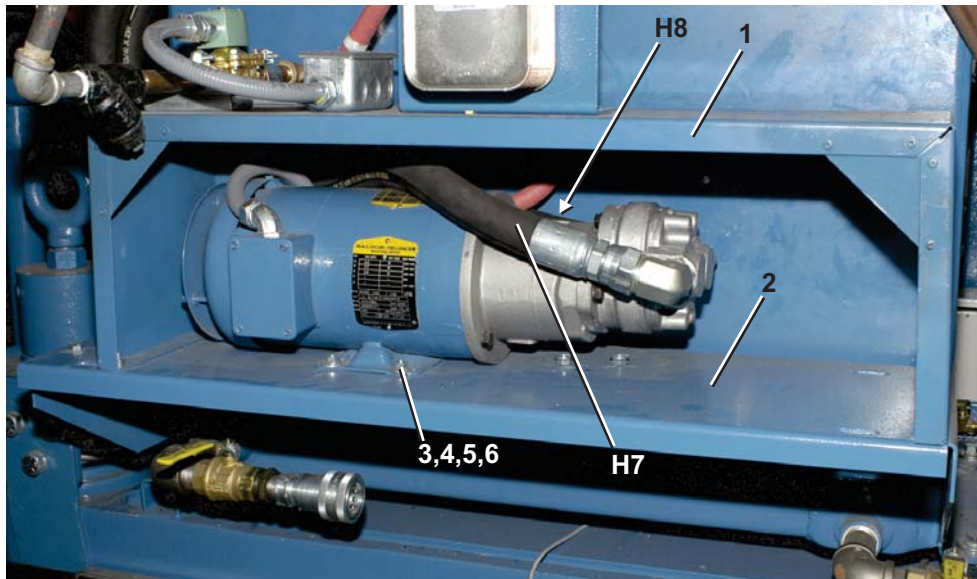
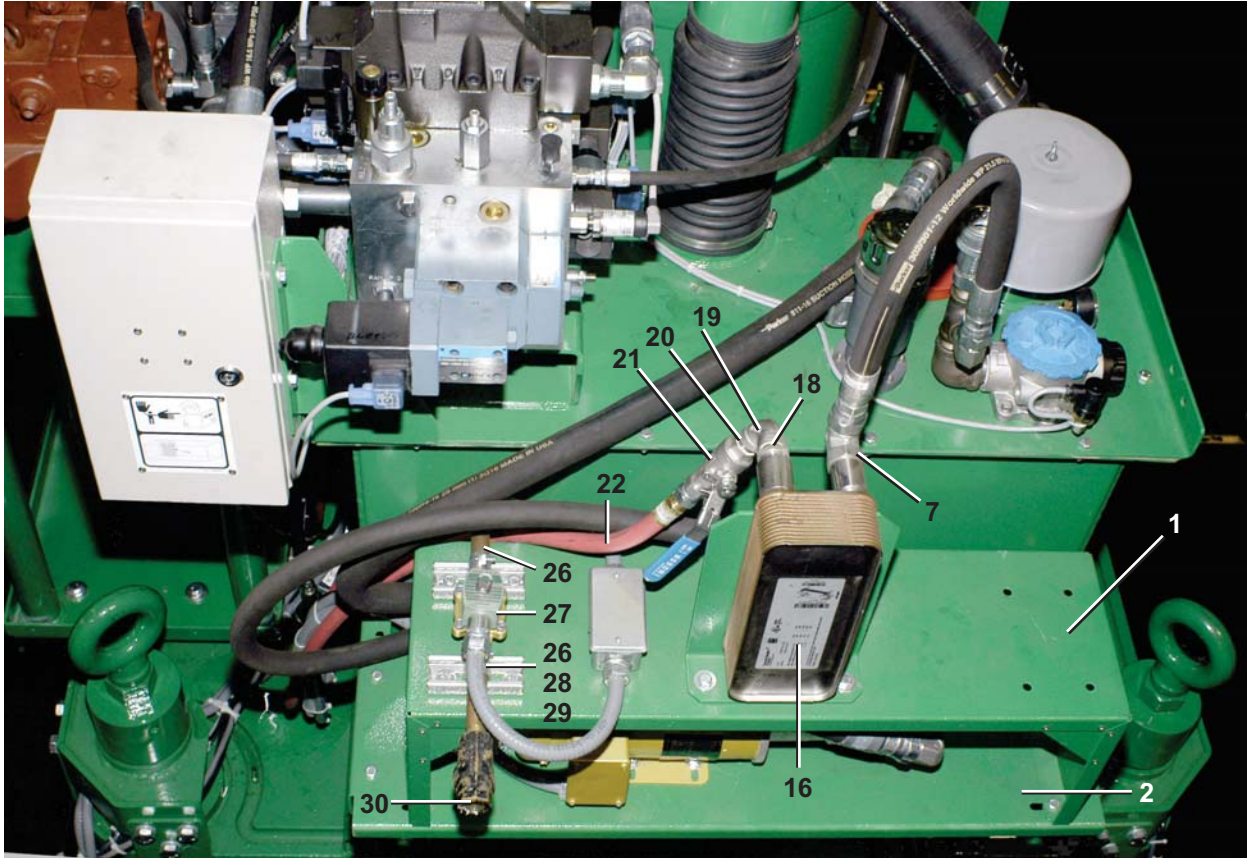

Alternate Cooler Pump Mounting 04/2016

Oil Cooler - Water Cooled

MP1540, MP1640, MP1556, MP1656, MP1A50
MPL550, MPL556, MPL640, MPL650, MPL656

Figure 2

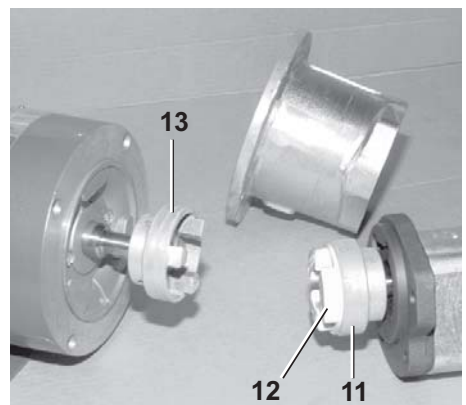
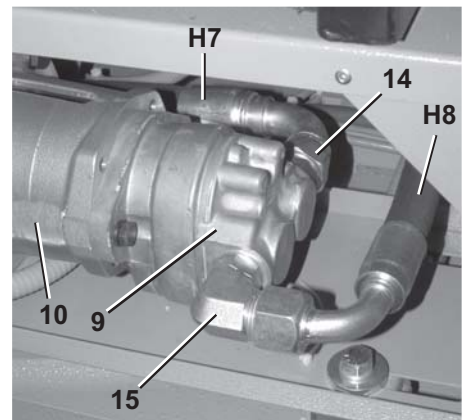
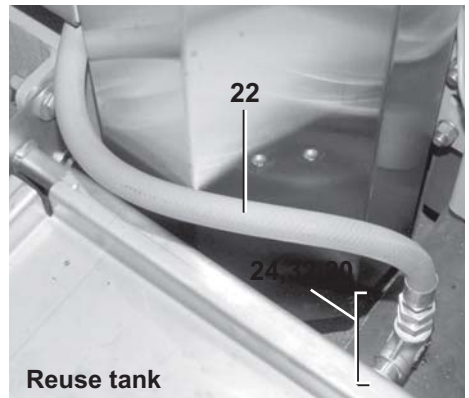
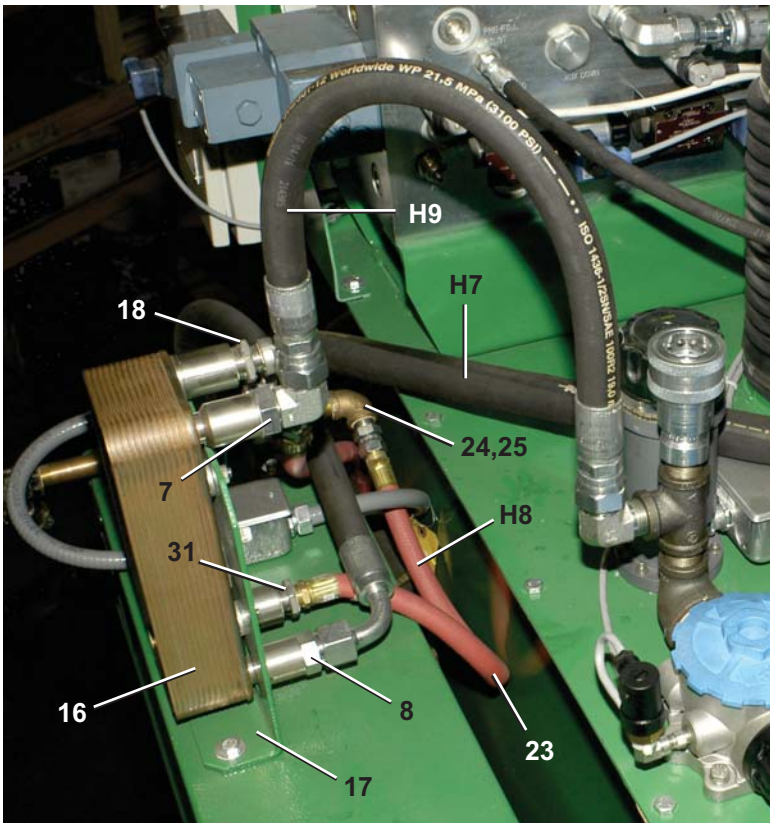

Cooler Pump Coupling Assembly

Oil Cooler - Water Cooled

**MP1540, MP1640, MP1556, MP1656, MP1A50
MPL550, MPL556, MPL640, MPL650, MPL656**

Parts List—Oil Cooler - Water Cooled				
Find the correct assembly first, then find the needed components. The item letters (A, B, C, etc.) assigned to assemblies are referred to in the "Used In" column to identify which components belong to an assembly. The item numbers (1, 2, 3, etc.) assigned to components relate the parts list to the illustration.				
Used In	Item	Part Number	Description	Comments
-----ASSEMBLIES-----				
	A	AHT10045	WATER COOLED COOLER-SSPRESS	REFERENCE
	B	G80CT001	GEN ASSY COOLING TOWER	used prior to 04/2016
	C	G80CT001A	GEN ASSY COOLING TOWER	used after 04/2016
-----COMPONENTS-----				
all	1	07 10308B	RECIRC PUMP HOUSING-TOP	
B	2	07 10796	RECIRC HOUSING BOTTOM	MP15xx, MP16xx
C	2	07 10798	RECIR HOUSING BOTTOM-MP1AXX	MP1A50
all	3	15K095	HXCPSCR 3/8-16UNC2AX1 GR5 ZINC	
all	4	15G205	HXNUT 3/8-16UNC2B ZINC GR2	
all	5	15U255	LOCKWASHER MEDIUM 3/8 ZINCPL	
all	6	15U240	FLATWASHER(USS STD) 3/8" ZNC P	
all	7	52ZJ00S009	TUBEFIT90EL3/4X5/8"FCSLO#12-10 C5OLO-S	
all	8	52ZC00S003	TUBEFIT STRTHDCN3/4"#12F5OLO-S	
all	9	27E5506	GEAR PUMP-RECIRC.PUMP-EATON	
all	10	27E5506A	PUMP TO MOTOR MOUNT	
all	11	27E5506G	COUP ASSY=5/8" BORE X 5/32" KW	
all	12	27E5506D	URETHANE INSERT FOR COUP.ASSY.	
all	13	27E5506B	COUP.ASSY=5/8"BORE X 3/16"KW	
all	14	52XY0KR050	STRDPT 3/4MX1"MJ#6400-16-12-0	
all	15	52ZC00S005	TUBEFIT 3/4"X5/8"#12-10F50L0S	
all	15	52ZJ00S007	TUBEFIT90ELFCSL3/4"#12CLO-S	
	16	27H11205	SSPRESS HEAT EXCHANGER	before 5/2014
	16	27H11206	HEAT EXCHANGER THERMAL	after 5/2014
B	17	07 10310	HEAT EXCHG MTG BRKT	used prior to 04/2016
C	17	07 10310A	HEAT EXCHG BRKT=27H11206	used after 5/2014
all	18	5N0PCLSS42	NPT NIP 3/4XCLS TBE 304SS SK40	
all	19	5SL0PBEA0K	NPTELB 90DEG 3/4X1/2 BRASS150#	
all	20	5N0KCLSS42	NPT NIP 1/2XCLS TBE 304SS SK40	
all	21	96D040FSLH	1/2" BALVAL S/S LL/HDL	
all	22	60E085C264	HOSE ASSY=1/2"X264"LG+ENDS	
all	23	60E085C20A	HOSE ASSY=1/2" X 20"LG	

Oil Cooler - Water Cooled

MP1540, MP1640, MP1556, MP1656, MP1A50
 MPL550, MPL556, MPL640, MPL650, MPL656

Parts List—Oil Cooler - Water Cooled

Find the correct assembly first, then find the needed components. The item letters (A, B, C, etc.) assigned to assemblies are referred to in the "Used In" column to identify which components belong to an assembly. The item numbers (1, 2, 3, etc.) assigned to components relate the parts list to the illustration.

Used In	Item	Part Number	Description	Comments
all	24	51X017	UNIONSTRADT 1/2"#1404-8-8	
all	25	5SL0KSFA	NPTELB 90DEG 1/2 304SS 150#	
all	26	5N0K02AG42	NPT NIP 1/2X2 TBE GALSTL SK40	
all	27	96TDC2AA37	1/2"N/C2WY120V50/60C VLV(DRYVC)	
all	28	02 04302	UNISTRUT, 13/16 X 4"	
all	29	27A0100	CLP-RGDSTL PS#1100-1	
all	30	51T025	Y-STRAINER 1/2" CAST IRON	
all	31	5SB0P0KSFO	NPTHEXBUSH 3/4X1/2 SS304 150#	
all	32	5SL0KBEA	NPTELB 90DEG 1/2 BRASS 125#	
all	H7	60EH81C66A	HYD FLEX HOSE 2-STRFEMSW 1"X66"LG	
all	H8	60EH50C48D	HYD HOSE 90+STR.FMORSW 3/4"X48"LG	
all	H9	60EH50C22B	HYD HOSE 2-STRFEMSW 3/4"X22"LG	

Hydraulic Schematic - Ram Command™ (Delicate Goods) Option

Single Manifold - Ram Command™ (current)

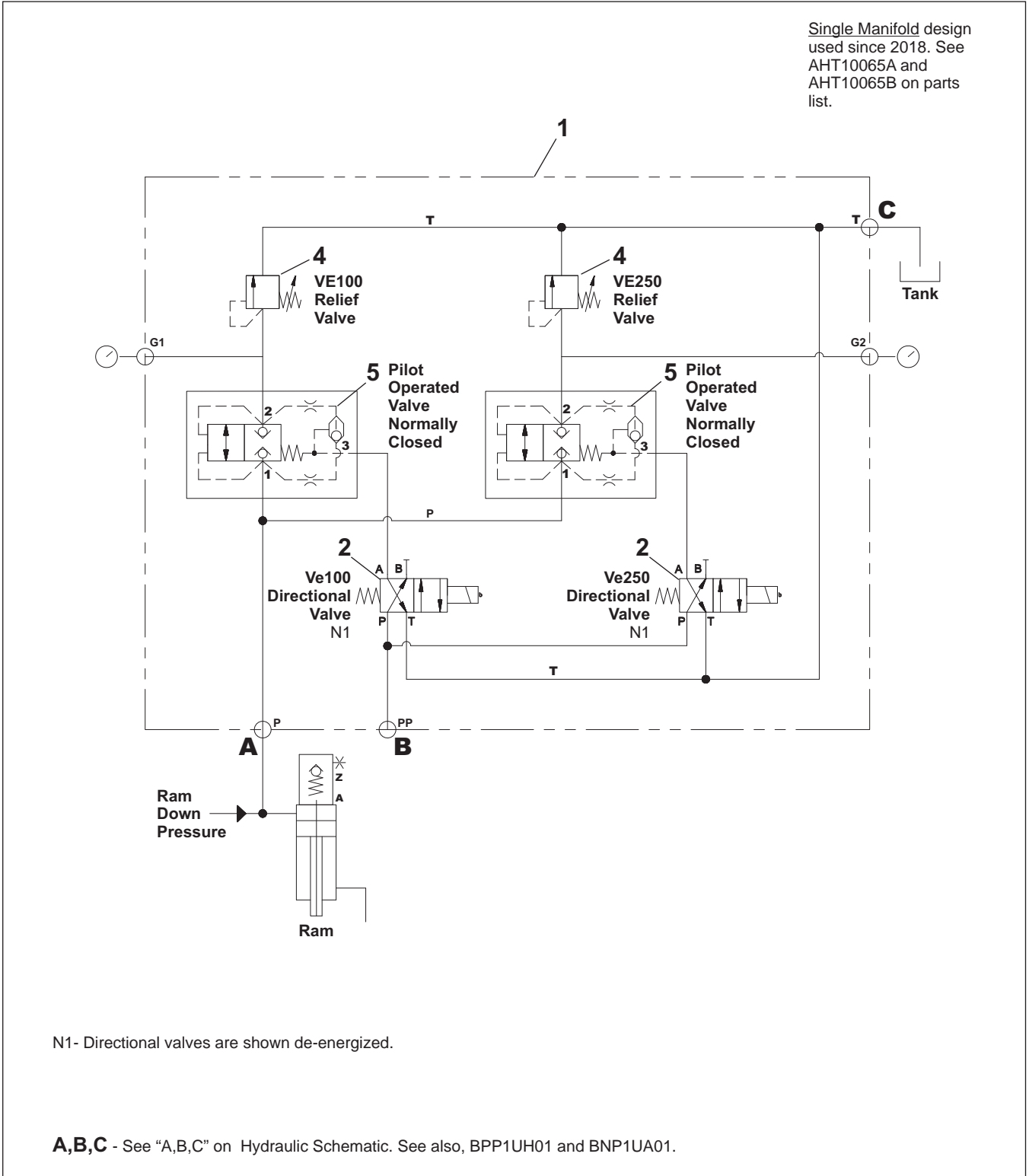

Hydraulic Schematic - Ram Command™ (Delicate Goods) Option

Multi-Manifold - Ram Command™ (obsolete)

Multi-Manifold design used till 2018. See AHT100065 on parts list.

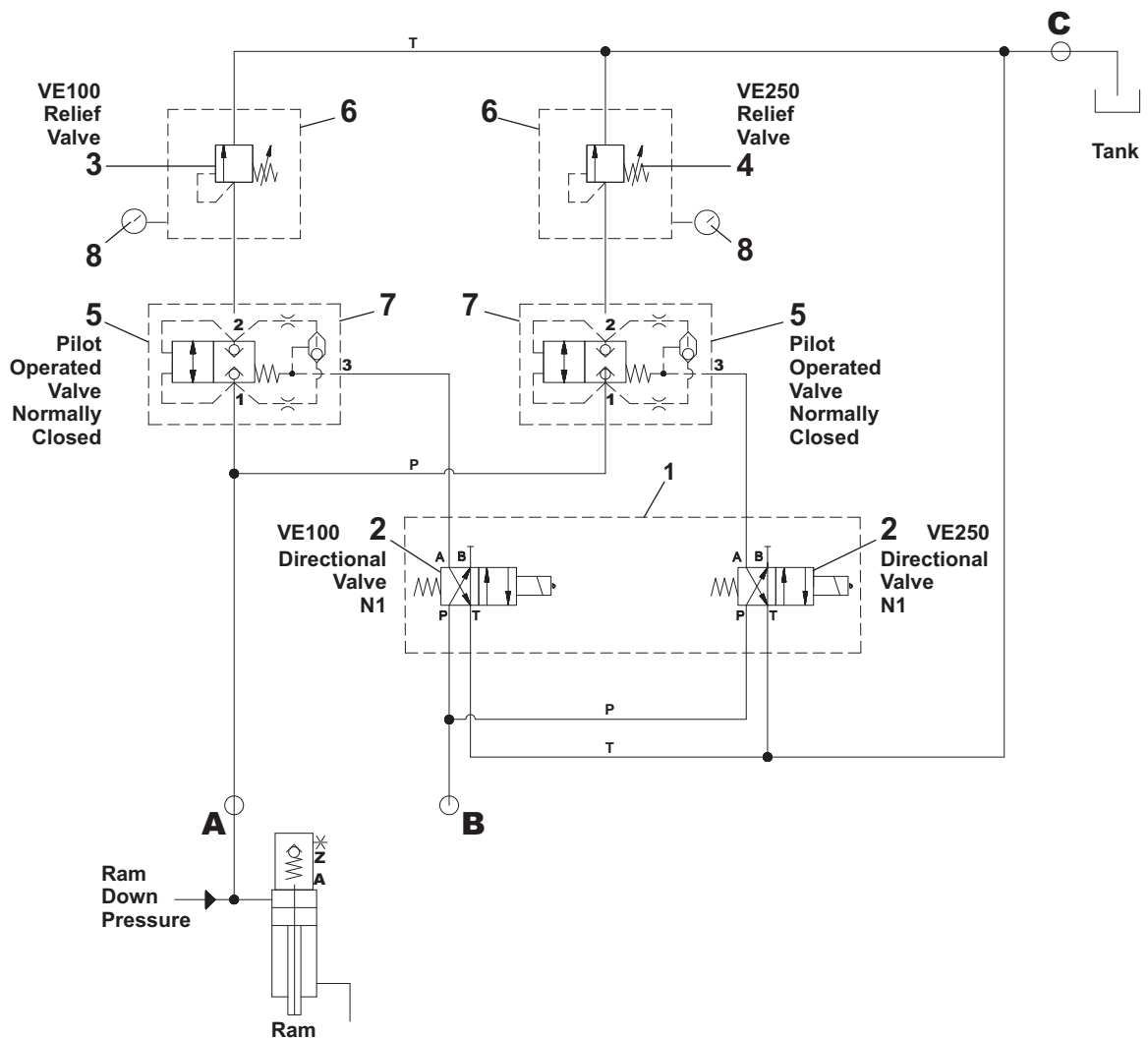

N1- Directional valves are shown de-energized.

A,B,C - See "A,B,C" on Hydraulic Schematic. See also, BPP1UH01 and BNP1UA01.

Hydraulic Schematic - Ram Command™ (Delicate Goods) Option

Parts List—Hydraulic Schematic Delicate Goods Find the correct assembly first, then find the needed components. The item letters (A, B, C, etc.) assigned to assemblies are referred to in the "Used In" column to identify which components belong to an assembly. The item numbers (1, 2, 3, etc.) assigned to components relate the parts list to the illustration.				
Used In	Item	Part Number	Description	Comments
-----REFERENCE ASSEMBLIES-----				
	A	AHT10065	DELICATE GOODS RELIEF VALVES ASSY	MP15_, MP16_, MP1A_ BEFORE 2018
	B	AHT10065A	DELICATE GOODS ASSY FOR 96DH463 MANF	MP15_, MP16_, MPL550, MPL650, MPL656 SINCE 2018
	C	AHT10065B	DELICATE GOODS ASSY 96DH462A 96DH464	MP1A50 SINCE 2018
-----COMPONENTS-----				
A	1	96DH486	MANIFOLD DAMAN DD03P022S	
B,C	1	96DH481	MANIFOLD DELICATE GOODS SUN # FV 12455 V1 PPP	
ABC	2	96RH712A02	DIRECTIONAL PILOT VALVE+SOL 24VDC	
A	3	96DH497	VALVE DIRECT RELIEF RDFA-LSN	
A,B,C	4	96DH496	VALVE DIRECT RELIEF RDFA-LEN	
A,B,C	5	96DH498	VALVE CARTRIDGE SUN #LOFD XDN	
A	6	96DH493	BODY, SUN BCLS	
A	7	96DH495	BODY, STEEL SUN CAM/S	
A	8	30N125W	WIKA GAGE 7/16-20SAE 2000PSI/B	

RAM Command™ Option Adjustment

BNP1UA01.C01 0000278199 D.2 C.5 3/21/22 11:07 AM Released

This document applies to all 1-station press models available with the RAM Command™ option (also called the delicate goods option and formerly called *soft squeeze*). It applies to current production presses with the single manifold hydraulic piping design as well as to older presses with the multi-manifold design.

The document addresses two on-site activities that can be needed:

- Set RAM Command™ pressures either to use different pressures than those set at the factory or because components were replaced.
- Disable the RAM Command™ option to make it easier to troubleshoot the hydraulic system.



NOTICE: Understand the press servicing hazards. Do this procedure only if you understand and work with hydraulic systems. Review the press safety guide and the safety information in the parts and service manual.

1. Concept of Operation

BNP1UA01.C06 0000278753 D.2 B.3 3/21/22 11:14 AM Released

In summary, the RAM Command™ system applies a very gradual build-up of pressure, which gives sensitive goods time to release water without damage. This system pressurizes the ram in a timed sequence of low, but increasing pressure steps. The factory-set pressures can be reset by the customer. The step durations are specified in programmable press codes.



NOTE: Refer to document BMP1400021 “Hydraulic Schematic - RAM Command™...” in the service manual to assist in understanding this information.

The system uses two electrically operated valves, each with an associated pilot operated valve and an adjustable relief valve.

When a RAM Command™ press code is not in effect, valve VE100 and valve VE250 are de-energized, both pilot operated valves are closed, blocking ram pressure to relief valves. The press will operate at standard pressure.

When a RAM Command™ press code is in effect, the RAM Command™ system builds up ram down pressure in a four step sequence, as follow:

1. Valve VE100 is energized, the associated pilot operated valves open allowing flow to the relief valve. Ram down pressure will be at this relief valve setting. Valve VE100 remains open for the Timer A duration then closes.
2. Valve VE250 is energized, the associated pilot operated valves open, allowing flow to the relief valve. Ram down pressure will be at this relief valve setting. Valve VE250 remains open for the Timer B duration then closes.
3. The ram down pressure increases to standby pressure for the Timer C duration..
4. The RAM Command™ sequence ends and standard pressures take effect.



NOTE: On machines with the RAM Command™ option, the standard ram up relief pressure is permanently set to 950 psi. This pressure is set to 1500 psi on machines without the option. Although this setting is determined by whether or not the machine has the RAM Command™ option, it is otherwise, independent of the RAM Command™ system.

2. How RAM Command™ Press Codes Work

BNP1UA01.C02 0000278198 D.2 B.3 3/12/20 4:12 PM Released

When you apply the RAM Command™ function to a press code, the pressing cycle begins with a sequence of three low, but increasing pressure steps. The press code controls the length of time that each pressure will occur, but not the pressures themselves. The times appear on the press code screen as Timers A, B and C, shown at the bottom left of the figure below. You can specify up to 99 seconds for each timer. A value of 00 for any timer causes the machine to skip that pressure step and proceed to the next pressure.

Figure 1. Enter time values in the fields for Timers A, B, and C at the bottom left of the screen.

	S-01	S-02	S-03
BAR	18		
Secs	020		
Tamp	0		
Max	025		
End	1		

P06
POLYSHIRTS

HELP

Timer C
Duration of ON time for the FLOW CONTROL output.
Range is 00-99 seconds.
00 = Disabled

Timer A 99
Timer B 99
Timer C 99

3. Pressure Adjustment Preparations

BNP1UA01.R01 0000278778 D.2 B.3 3/21/22 9:28 AM Released

When To Adjust Pressures — If you replace pressure components, it can be necessary to re-establish all hydraulic pressures, including the RAM Command™ pressures on site. If you wish to use pressure values different from the factory settings, you can change the Timer A and Timer B pressures without affecting the standard pressures.

Pressure Adjustment Rules

- Timer A pressure must be lower than Timer B pressure.
- The Timer A and Timer B pressures must not exceed standby pressure (400 or 500 psi, depending on model).

Requirements

Tools Each relief valve has a locknut and an adjustment screw. Provide a 9/16" wrench for the locknut and a 5/32" Allen wrench for the adjustment screw. Also provide a safe platform to work at the location of the valves. On newer press models, the pressure gauges are not permanently attached; however, the necessary pressure gauges are provided with the machine. Make sure these gauges are on hand.

Two personnel One person (referred to herein as the **operator**) starts and stops the press code at the operator controls. The other person (referred to herein as the **technician**) makes the adjustments at the valves. The personnel must be able to clearly communicate with each other. Review this instruction to understand the necessary coordination between the operator and the technician.

Adjustment press code Create a dedicated press code or temporarily modify an existing press code that you will use to make the adjustments. **You must do these pressure adjustments with goods in the machine** and a press code running in automatic, and you must do each adjustment during the programmed time that the valve is energized. For this reason, temporarily set the Timer A and Timer B durations to the maximum value (99 seconds). The only important part of this press code is the Timer A and Timer B values. See the 1-station press reference manual for general programming information.

Press loaded If you cannot do these procedures with an actual load of goods while production is paused, load and wet down a batch of goods in the press by any safe means.



TIP: Electrical schematics W6PM1SSQ and W6PM1SVSB in the 1-Station press schematic manual and parts document BPP1UH01 “Delicate Goods Option (RAM Command™ Ram Control)” in the parts and service manual can assist with troubleshooting the Ram Command system.

RAM Command™ Factory Specifications

Table 1. Factory Specifications

Model Family	MP1540	1550	1556	1640	1650	1656	1A50
Bar Rating	40	50	56	40	50	56	50
Ram Bore (inch)	14	14	14	14	16	16	17
Settings (PSI)							

Factory Specifications (cont'd.)

Model Family	MP1540	1550	1556	1640	1650	1656	1A50
Standby* (Timer C)	500	500	500	500	400	400	525
Ram Up Relief	950	950	950	950	950	950	950
Valve A (VE100) (Timer A)	220	220	220	250	200	200	275
Valve B (VE250) (Timer B)	320	320	320	375	300	300	390

* Standby pressure is also referred to as idle pressure or ram down relief pressure.

4. Pressure Adjustment Operator Procedure

BNP1UA01.C04 0000278269 D.2 C.3 3/21/22 9:12 AM Released

This is a brief explanation. Review the 1-station press reference manual if necessary.

1. When a suitable batch is in the press, put the tunnel in hold to suspend production.
2. Set the press to Manual mode then return it to Automatic mode to initiate the sequence of operator prompts. Respond to the prompts as appropriate. In particular:
 - a. Answer yes to "Does press have a cake?"
 - b. At the Cake Data screen, leave all data as displayed except for the press code. Take note of the press code assigned to this batch then change it to the adjustment press code that you prepared.
 - c. When the technician is ready, answer no to "Discharge cake in can?" The machine will operate and permit the technician to do the adjustments explained in [Section 5 : Pressure Adjustment Technician Procedure, page 4](#).
3. When valve VE250 de-energizes (which ends the available adjustment time) and before the press code is complete, set the machine to Manual mode then return it to Automatic mode. If the adjustments are not complete, respond to the prompts the same way as before to restart the adjustment press code. Otherwise, respond as appropriate to resume production and permit this batch to process according to its actual press code.

5. Pressure Adjustment Technician Procedure

BNP1UA01.C05 0000278268 D.2 3/21/22 9:23 AM Released

This instruction tells how to set the first two pressures (for Timers A and B). The third pressure (for Timer C) is idle (standby) pressure, which is a standard pressure. The procedure to set idle pressure is explained in document BIPPMT02 "Set Standard and Booster Pump Pressures–1-station Press".

You adjust the pressures for Timers A and B on the relief valves associated with the electrically operated hydraulic valves VE100 and VE250 (see the figure below).

Figure 2. RAM Command™ System Hydraulic Adjustment Components

Views of Adjustment Components on Single-manifold Presses (assembly AHT10065A)

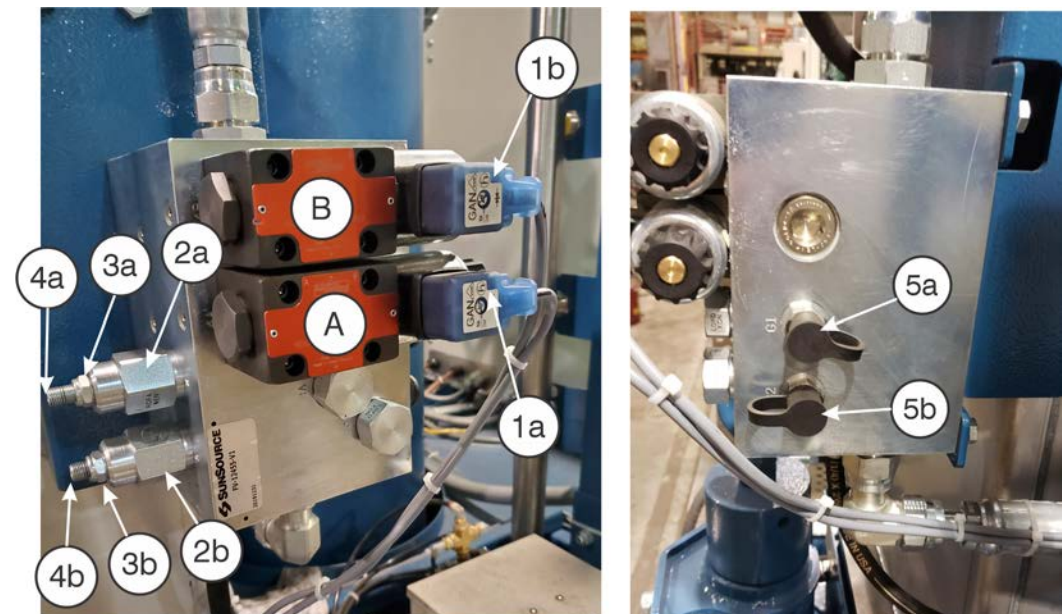

Views of Adjustment Components on Multi-manifold Presses (assembly AHT10065)

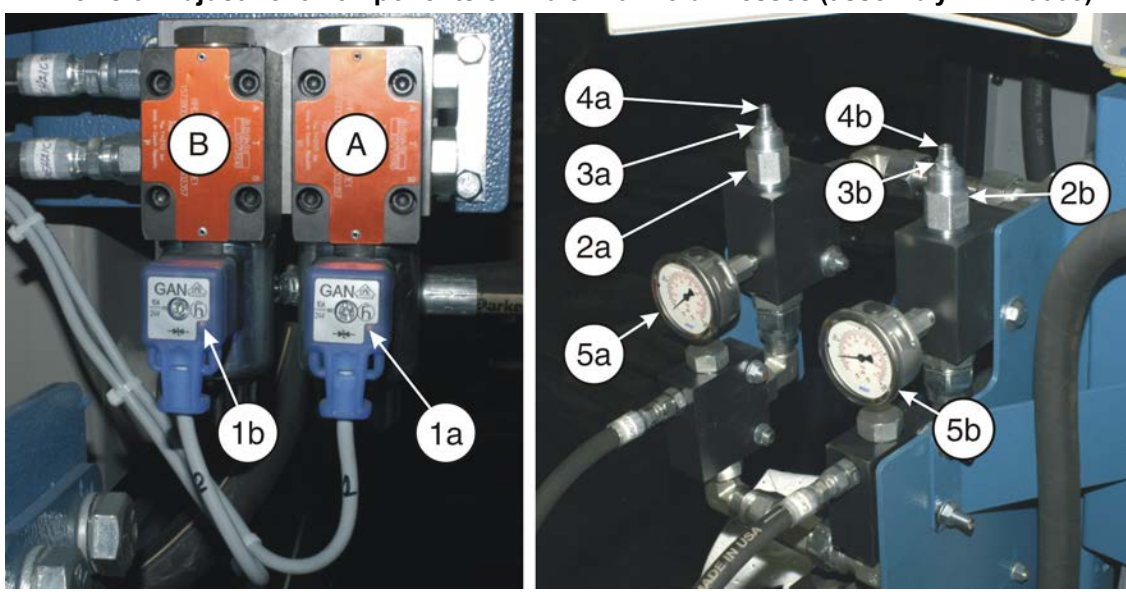

Legend

- A** Valve VE100 (electrically operated hydraulic valve for Timer A pressure).
- B** Valve VE250 (electrically operated hydraulic valve for Timer B pressure).
- 1a,1b** Light on electric connector. **Light on=**valve energized. **Light off=**valve de-energized. All "_a" items are for the Timer A pressure adjustment. All "_b" items are for the Timer B pressure adjustment.
- 2a,2b** Relief valve that must be adjusted for the factory pressure specified in [RAM Command™ Factory Specifications](#) or the customer-defined pressure.
- 3a,3b** Lock nut (9/16" hex)
- 4a,4b** Adjustment screw (5/32" Allen)
- 5a,5b** Pressure gauge connection point or pressure gauge. Read the pressure here during adjustment.



NOTICE: These adjustments are done with the machine in automatic operation.

- Do not use the maintenance key to set the machine to Maintenance mode.

Refer to [Figure 2, page 5](#). The lowest pressure adjustment is the relief pressure for valve A (VE100). This is the Timer A pressure. The adjustment components are those with "_a" item numbers in [Figure 2, page 5](#). Adjust as follows:

1. When the operator starts the adjustment press code, observe light 1a. Wait for the light to illuminate to indicate that valve VE100 is energized. This will occur when the descending ram clears the PXSM proximity switch (ram in container).
2. Loosen locknut 3a. Observe pressure gauge 5a and turn adjustment screw 4a until the gauge displays the pressure that you previously determined. If you cannot complete the adjustment in the 99 seconds that valve VE100 is de-energized (that the light is off), have the operator repeat the adjustment press code.
3. When the relief valve is correctly adjusted, tighten locknut 3a. The second lowest pressure adjustment is the relief pressure for valve B (VE250). This is the Timer B pressure. Adjust this pressure the same way as above. The adjustment components are those with "_b" item numbers in [Figure 2, page 5](#).

6. Disconnect the RAM Command™ System for Ease of Troubleshooting

BNP1UA01.C07 0000278775 D.2 A.3 3/12/20 4:21 PM Released

If it is necessary to troubleshoot the press hydraulic system, it can help to isolate the RAM Command™ manifold from the rest of the system. This is done by installing plugs at two hydraulic line connection points on the main manifold. The plugs are available from the Milnor® Parts department. The plug locations and part numbers are given in the figure below.

Figure 3. Plug Locations on the Main Manifold

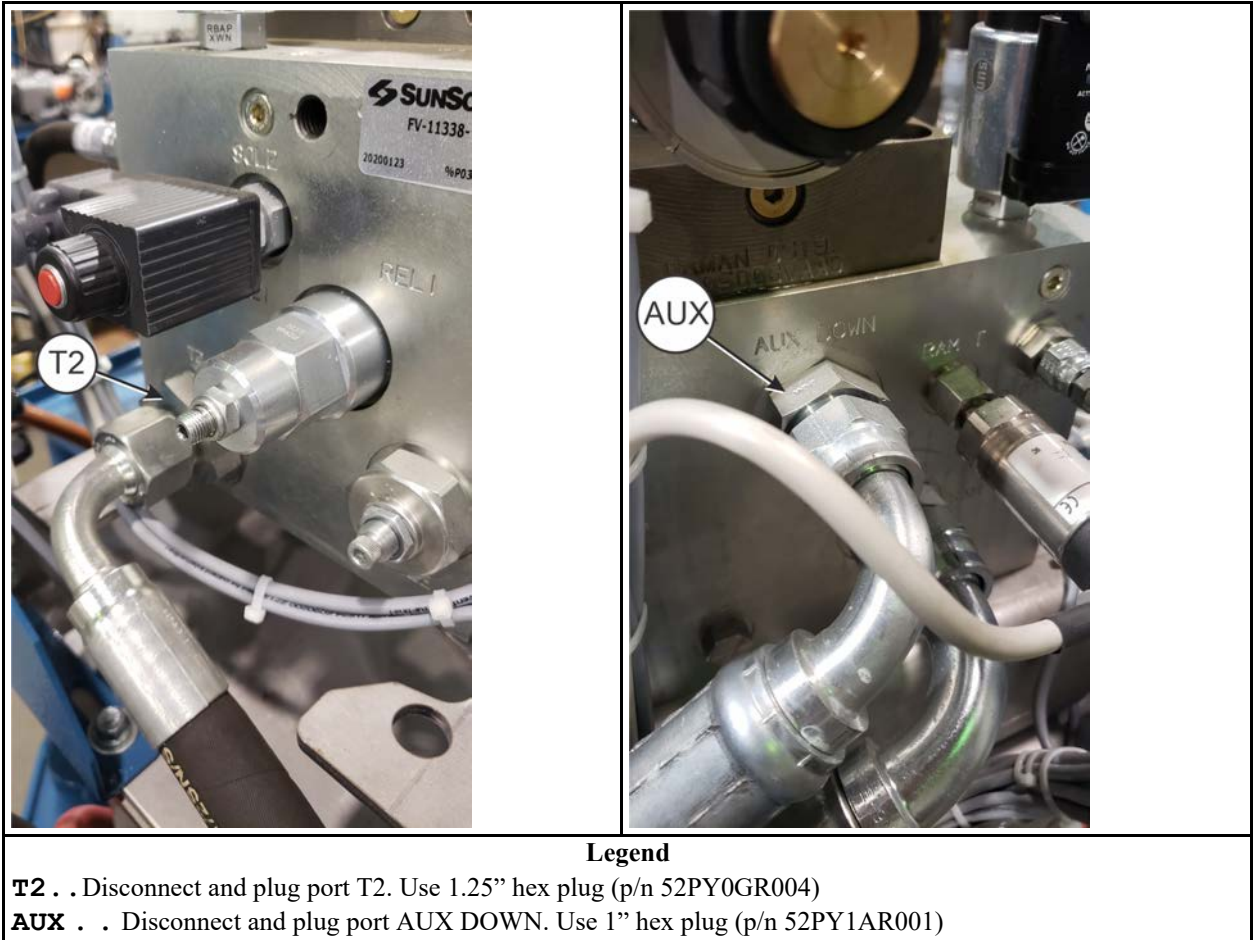

End of document: BNP1UA01

Delicate Goods Option

MP1540, MP1556, MP1640, MP1650, MP1656, MP1A50

Figure 1: Valves

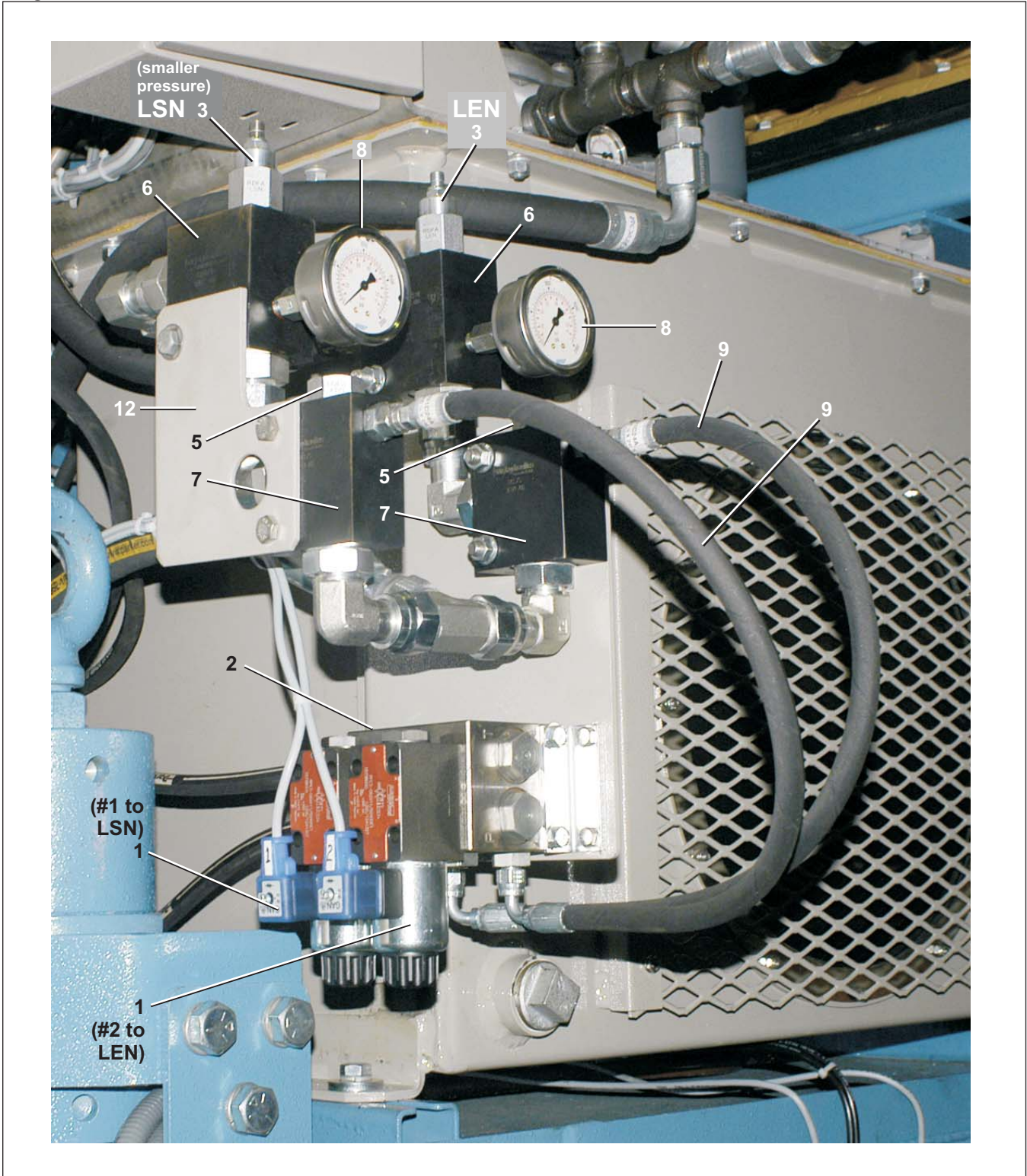

Delicate Goods Option

MP1540, MP1556, MP1640, MP1650, MP1656, MP1A50

Figure 2: Installation

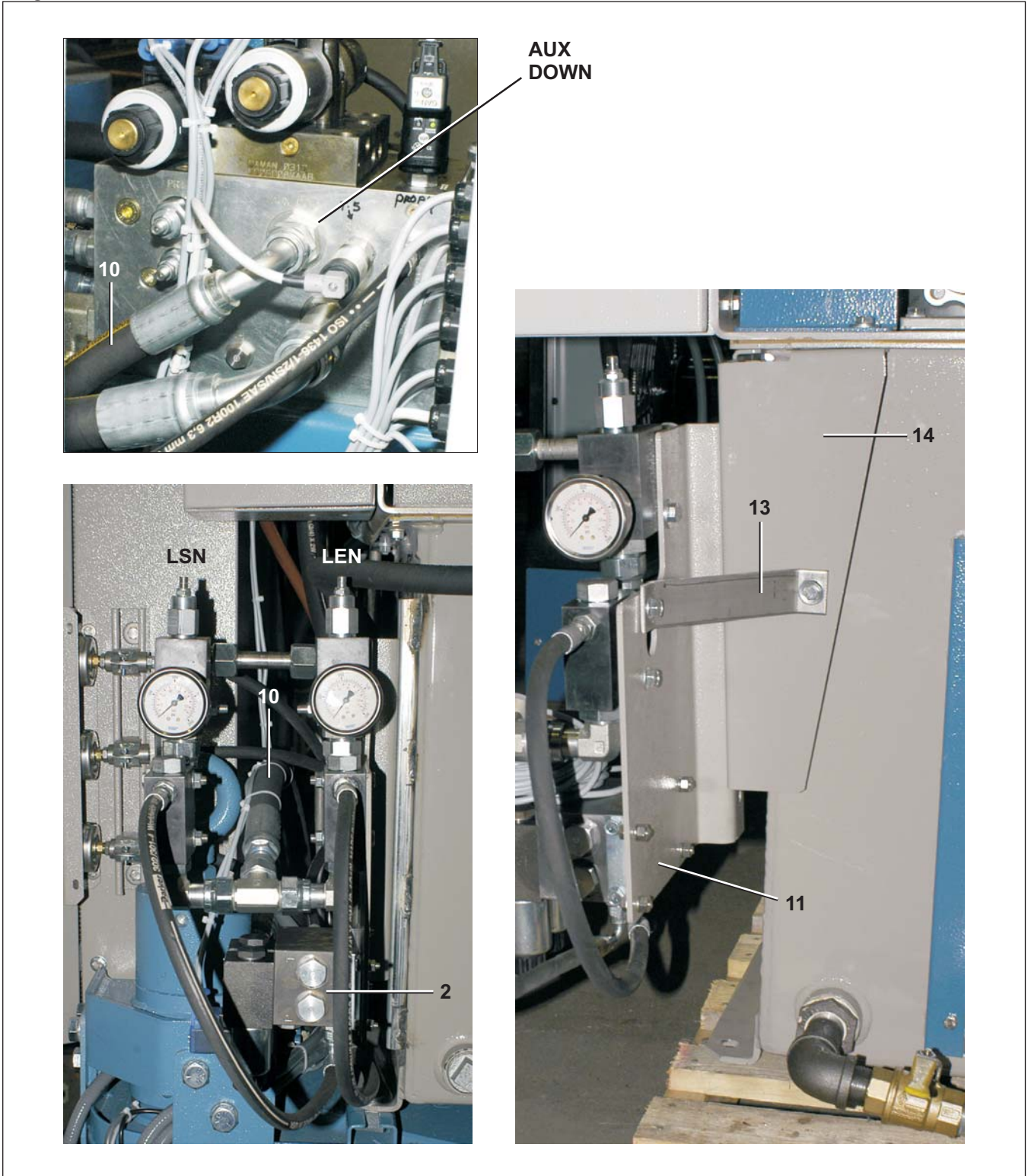

Delicate Goods Option

MP1540, MP1556, MP1640, MP1650, MP1656, MP1A50

Parts List—Delicate Goods Option				
Find the correct assembly first, then find the needed components. The item letters (A, B, C, etc.) assigned to assemblies are referred to in the "Used In" column to identify which components belong to an assembly. The item numbers (1, 2, 3, etc.) assigned to components relate the parts list to the illustration.				
Used In	Item	Part Number	Description	Comments
			-----ASSEMBLIES-----	
	A	AHT10065	DELICATE GOODS RELIEF VALVES ASSY	
			-----COMPONENTS-----	
all	1	96RH712A02	DIRECTIONAL PILOT VALVE+SOL 24VDC	
all	2	96DH486	MANIFOLD DAMAN DD03P022S	
all	3	96DH497	VALVE DIRECT RELIEF RDFA-LSN	
all	4	96DH496	VALVE DIRECT RELIEF RDFA-LEN	
all	5	96DH498	VALVE CARTRIDGE SUN #LOFD XDN	
all	6	96DH493	BODY, SUN BCLS	
all	7	96DH495	BODY, STEEL SUN CAM/S	
all	8	30N125W	WIKA GAGE 7/16-20SAE 2000PSI/B	
all	9	60EH21C24A	ASSY=HYDRAULIC HOSE 1/4 X24LG	
all	10	60EH51C80	ASSY=HI-PRESSURE HOSE 3/4"X80"LG	
all	11	07 10660	SOFT SQUEEZE VALVES MTG BRKT	
all	12	07 10660A	SOFT SQUEEZE VALVE BRKT	
all	13	07 10660B	SOFT SQUEEZE MANIFOLD BRACE	

Hydraulic Gages

MP1540, MP1556, MP1640, MP1650, MP1656, MP1A50

BMP110026/2012055A
(1 / 2)



Pellerin Milnor Corporation
P. O. Box 400, Kenner, LA 70063-0400

Litho in U.S.A.

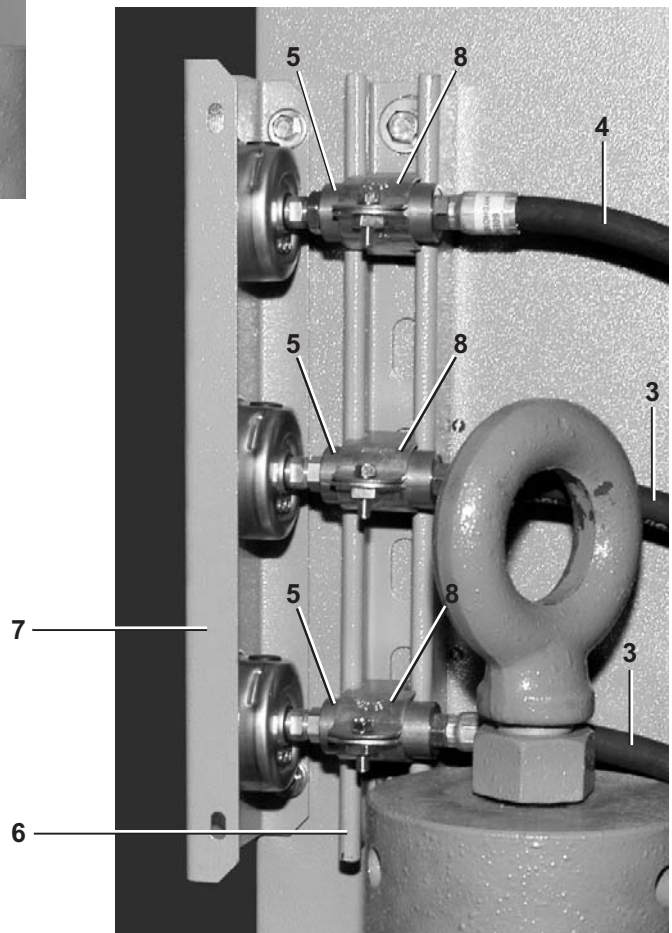
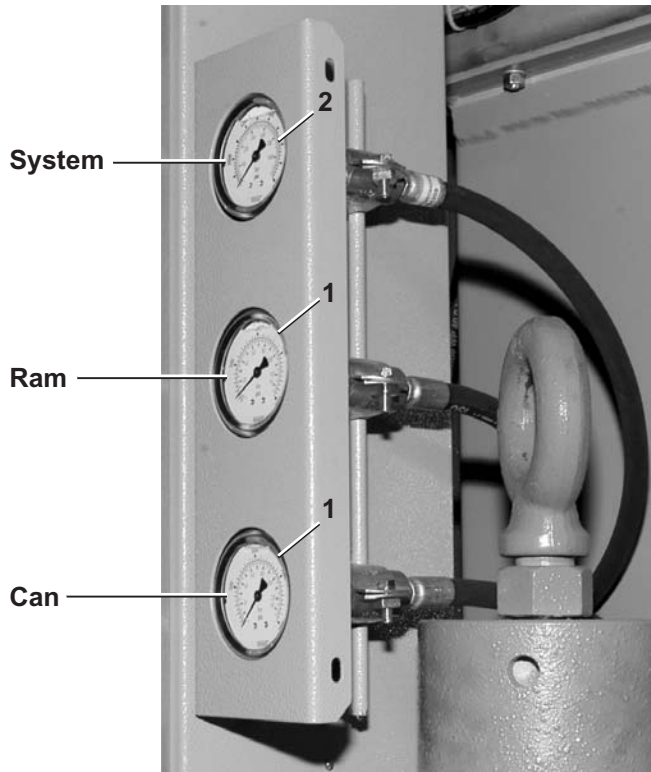



Pellerin Milnor Corporation
P. O. Box 400, Kenner, LA 70063-0400

Litho in U.S.A.

Parts List—Hydraulic Gages

Find the correct assembly first, then find the needed components. The item letters (A, B, C, etc.) assigned to assemblies are referred to in the "Used In" column to identify which components belong to an assembly. The item numbers (1, 2, 3, etc.) assigned to components relate the parts list to the illustration.

Used In	Item	Part Number	Description	Comments
-----ASSEMBLIES-----				
	A	AHT10012	GAGE ASSEMBLY 35/50BAR SSPRESS	MP1540, MP1556 MP1640, MP1656, MP1650
	B	AHT10012A	GAGE ASSEMBLY-MP1A03	MP1A56
-----COMPONENTS-----				
all	1	30N125W	WIKA GAGE 7/16-20SAE 2000PSI/B	
all	2	30N127W	WIKAGAGE 7/16-20SAE 10000PSI/B	
A	3	60EH21C60B	ASSY=HYD HOSE 1/4X60 GAGE SSPR	
B	3	60EH21C90B	ASSY=HYD HOSE 1/4X90 GA MP1A03	
A	4	60EH21C60C	ASSY=HYD HOSE 1/4X60 GA SSPRES	
B	4	60EH21C90C	ASSY=HYD HOSE 1/4X90 GA MP1A03	
all	5	X7 10281	PRES.GAGE O-RING SAE-4 PORT	
all	6	03 60250C	UNISTRUT-14" (COLOR=WARM GRAY)	
all	7	07 10249	PRESSURE GAGES MTG BRKT	
all	8	27A0075	CLP-RGDSTL PS#1100-3/4	

Hydraulic Ram and Diaphragm

MP1540, MP1556, MP1640, MP1656, MP1A56
MPL556, MPL640, MPL656

BMP110038/2021055A
(1 / 8)



Pellerin Milnor Corporation
P. O. Box 400, Kenner, LA 70063-0400

Litho in U.S.A.

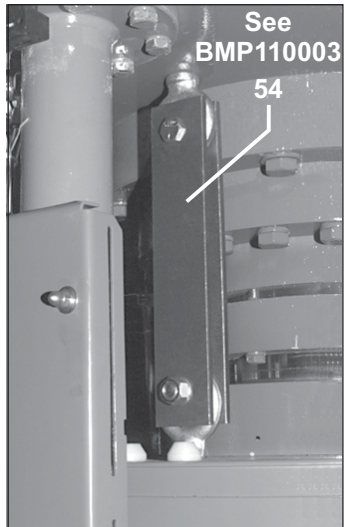

Diaphragm Safety Bar:
*(Install before servicing.
See BIUUUS27, Safety for Service Personnel.)*

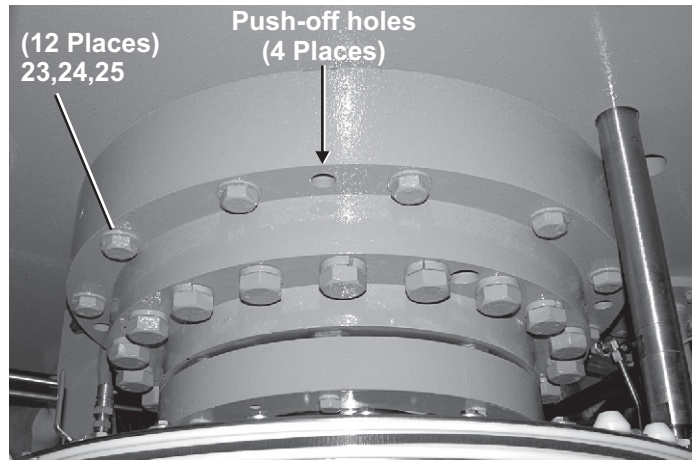

**Figure 1: Hydraulic Ram to
Upper Press Weldment**
(See Detail A.)

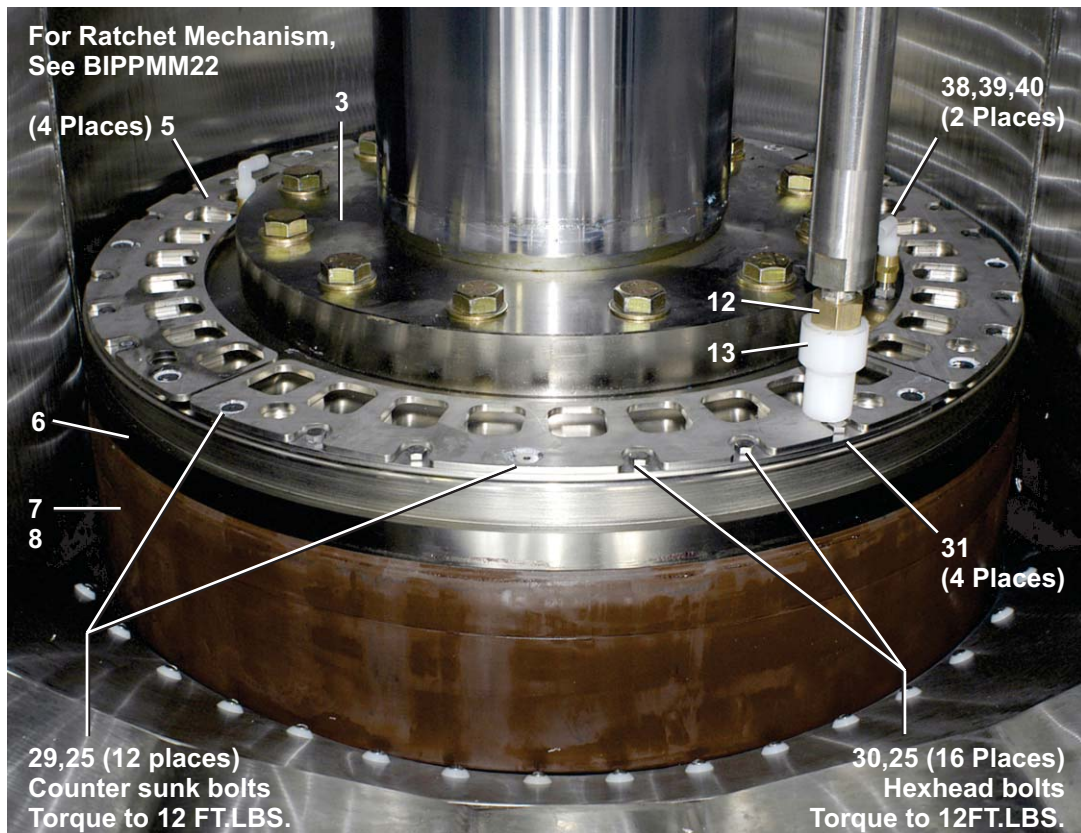

Figure 2: Upper Diaphragm

Hydraulic Ram and Diaphragm

MP1540, MP1556, MP1640, MP1656, MP1A56
MPL556, MPL640, MPL656

BMP110038/2021055A
(2 / 8)



Pellerin Milnor Corporation
P. O. Box 400, Kenner, LA 70063-0400

Litho in U.S.A.

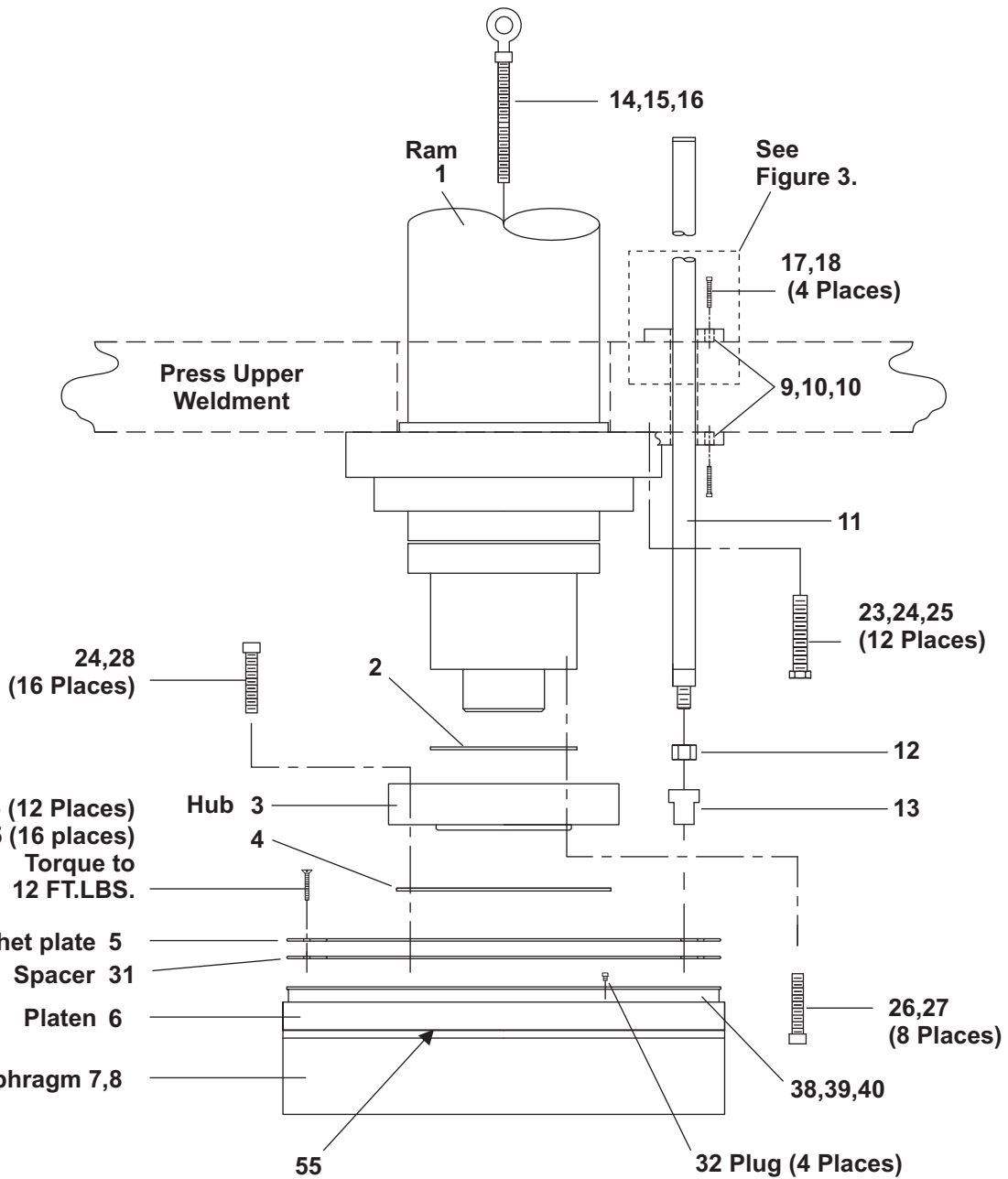

Apply Loctite Gasket Eliminator to the metal ring of the diaphragm that touches the platen, before mating these components.

Detail A

Hydraulic Ram and Diaphragm

MP1540, MP1556, MP1640, MP1656, MP1A56
MPL556, MPL640, MPL656

BMP110038/2021055A
(3 / 8)



Pellerin Milnor Corporation
P. O. Box 400, Kenner, LA 70063-0400

Litho in U.S.A.

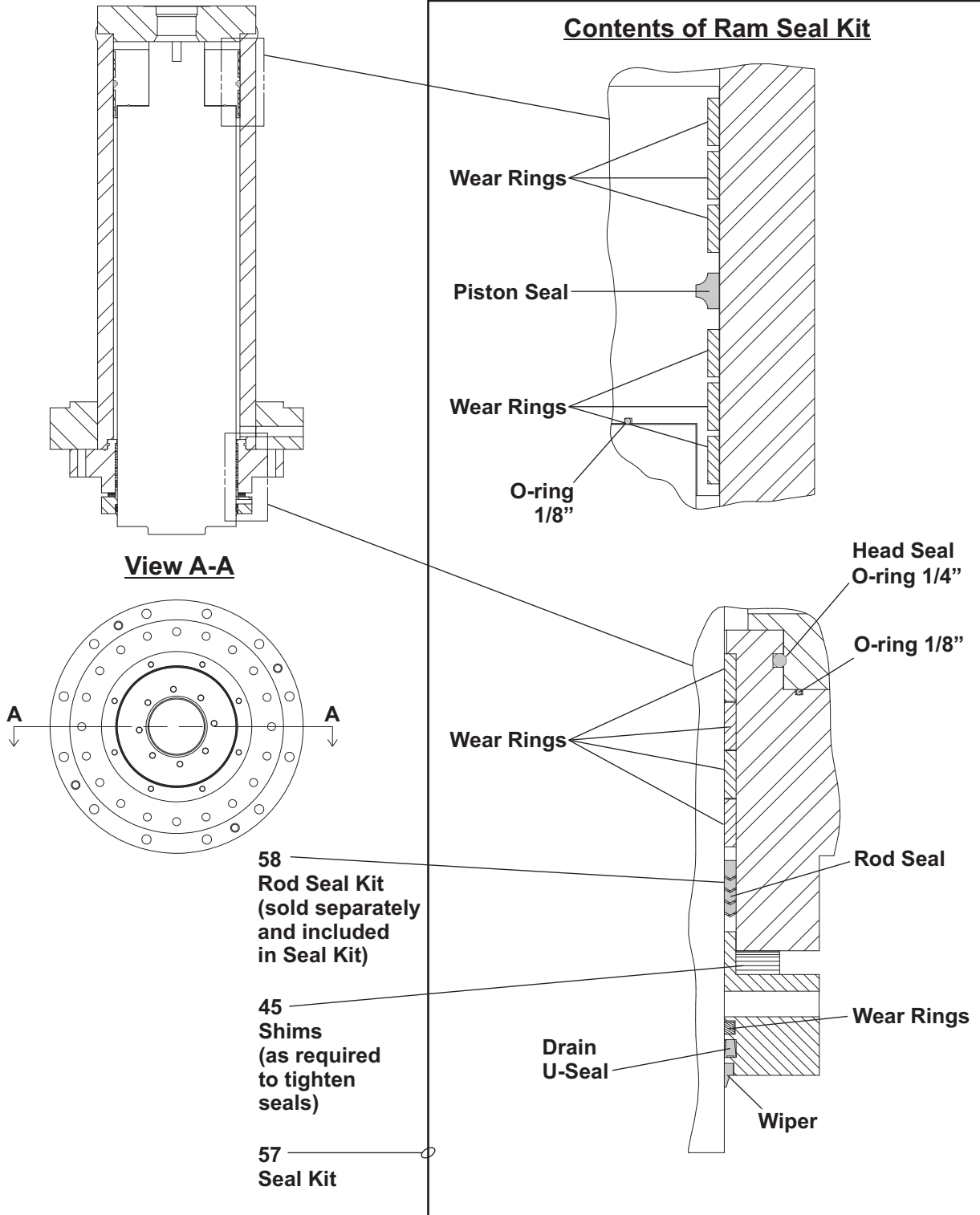

Hydraulic Ram and Diaphragm

MP1540, MP1556, MP1640, MP1656, MP1A56
MPL556, MPL640, MPL656

BMP110038/2021055A
(4 / 8)



Pellerin Milnor Corporation
P. O. Box 400, Kenner, LA 70063-0400

Litho in U.S.A.

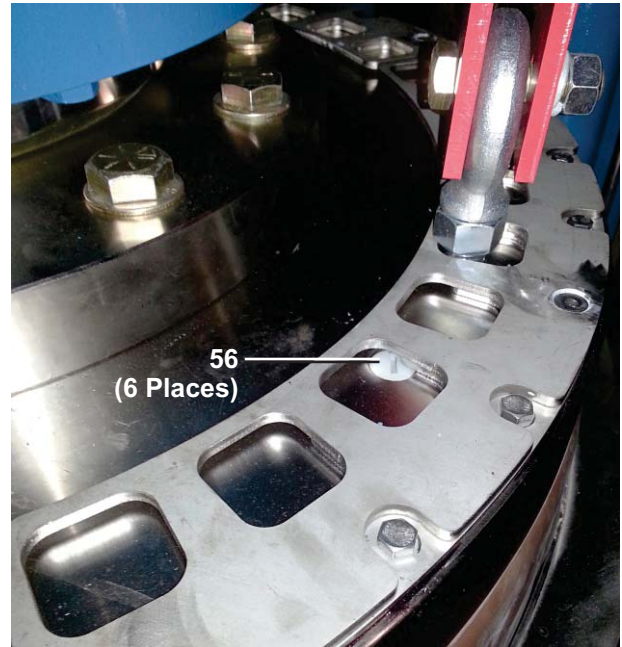
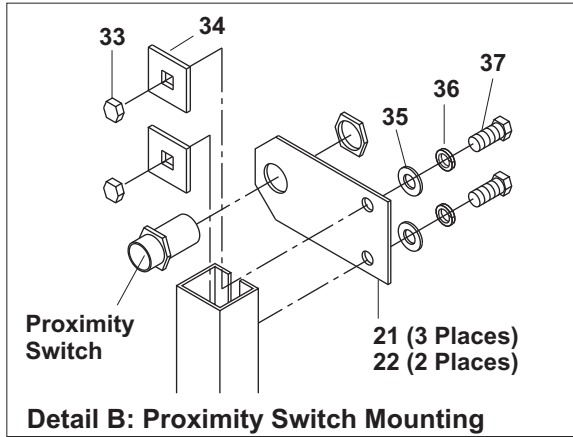

Figure 4: Platen plugs

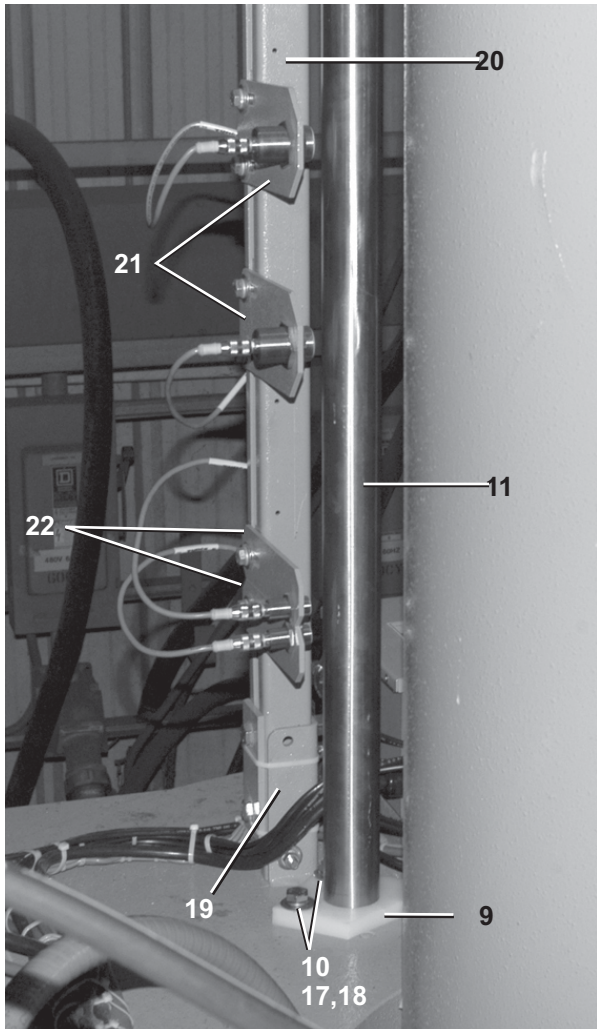

Figure 3: Proximity Switch Mounting Post

Hydraulic Ram and Diaphragm

MP1540, MP1556, MP1640, MP1656, MP1A56
MPL556, MPL640, MPL656

BMP110038/2021055A
(5 / 8)



Pellerin Milnor Corporation
P. O. Box 400, Kenner, LA 70063-0400

Litho in U.S.A.

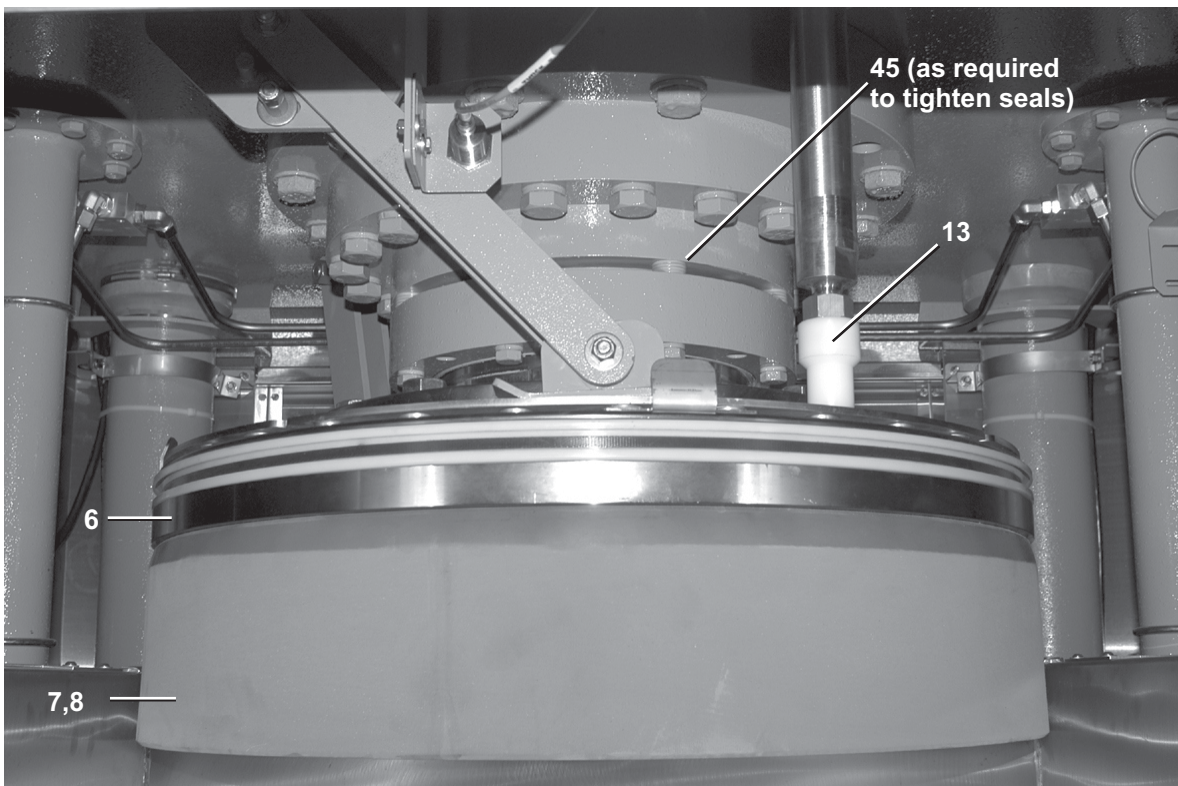
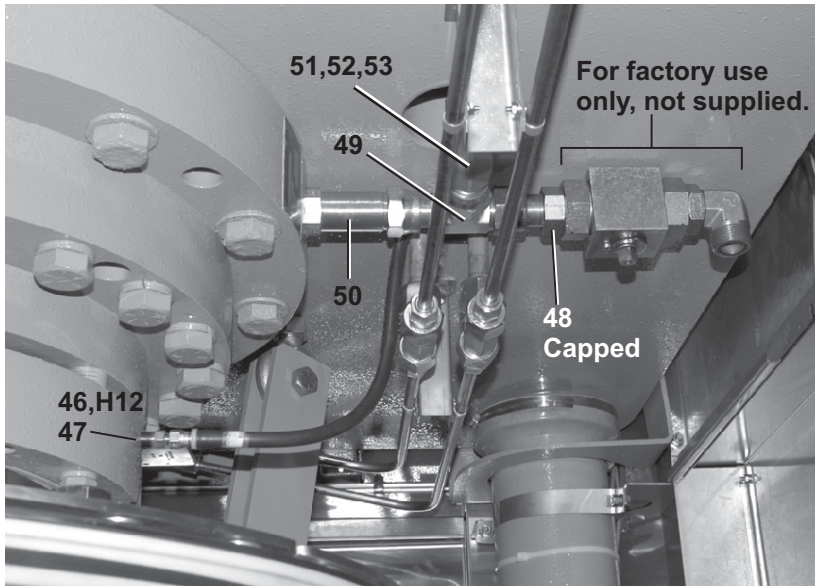

Figure 4: Hydraulic Ram and Diaphragm

Hydraulic Ram and Diaphragm

**MP1540, MP1556, MP1640, MP1656, MP1A56
MPL556, MPL640, MPL656**

**BMP110038/2021055A
(6 / 8)**

Parts List—Hydraulic Ram and Diaphragm

Find the correct assembly first, then find the needed components. The item letters (A, B, C, etc.) assigned to assemblies are referred to in the "Used In" column to identify which components belong to an assembly. The item numbers (1, 2, 3, etc.) assigned to components relate the parts list to the illustration.

Used In	Item	Part Number	Description	Comments
-----MODEL REFERENCES-----				
	A	MP1540B	MP1540 40 BAR PRESS BASE MODEL	MP1540, MP1550
	B	MP1556B	MP1556 56 BAR PRESS BASE MODULE	MP1550, MP1556 MPL556
	C	MP1640B	MP1640 40 BAR PRESS BASE MODULE	MP1640, MPL640
	D	MP1656B	MP1656 56 BAR PRESS BASE MODEL	MP1650, MP1656, MPL650, MPL656
	E	MP1A56B	MP1A56 56BAR BASE MODULE	MP1A50, MP1A56
AB	F	GHC10004	DIAPHRAGM/PLATEN INST-MP1556	
CD	G	GHC10002	DIAPHRAGM/PLATEN INST-MP16XX	
E	H	GHC10003	DIAPHRAGM/PLATEN INST-MP1AXX	
-----COMPONENTS-----				
A	1	27E1613391	HYD.RAM 13"BORE X 39" STROKE CATIC	
BC	1	27E161439A	RAM 14"BORE X 39"STK W/SIDEPOR	
D	1	27E161639A	RAM 16"BORE X 39"STK W/SIDEPOR	
E	1	27E161749A	RAM 17"BORE X 49"STK W/SIDEPOR	
all	2	60C180V	ORING 11"IDX1/8CS V70D#276	
ABCD	3	X7 10040C	PLATEN HUB MACHINED-47BAR	
E	3	X7 10034	PLATEN HUB MACHINE-48"MEMBRANE	
ABCD	4	60C193A	ORING 22"ID 1/4CS BUNA70-471	
E	4	60C193B	ORING 26"ID 1/4CS BUNA70-475	
AB	5	07 10571A	DIAPHRAGM ROTATING PL-MP1550	
CD	5	07 10571	DIAPHRAGM ROTATING PLATE	
E	5	07 10602	DIAPHRAGM ROTATING PLATE-MP1A03	
AB	6	X7 10068	MEMBRANE PLATEN 900MM	
CD	6	X7 10052	MEMBRANE PLATEN SSPRESS	
E	6	X7 10035	PLATEN SSPRESS-48" MEMBRANE	
AB	7	ACW10003R	MEMBRANE/RING ASSY 900MM SBR	
CD	7	ACW10001R	MEMBRANE/RING ASSY 40" SBR	
E	7	ACW10002	MEMBRANE/RING ASSY 48"	
AB	8	ACW10012A	GUM RUBBER 11PCS SET-36MEM	
CD	8	ACW10010A	GUM RUBBER 11PCS SET-40MEM	
E	8	ACW10011A	GUM RUBBER 11PCS SET-48MEM	
all	9	07 10581	DIAPHRAGM ROD LOWER GUIDE	
all	10	27B34010SS	SPACERROLL .51ID.625L.062T SS	
ABCD	11	X7 10254	DIAPH ROD 1-8UN MACHINED	
E	11	X7 10383	MEMBRANE GUIDE ROD-MP1A03	
all	12	15G250B	HEXNUT 1-8UNC2B BRASS	
all	13	X7 10250	GUIDE ROD UHMW BASE	
all	14	17A122	EYE NUT 1.25-7 GAL. STEEL	
all	15	17R125A14K	1-1/4-7X14 STUD B7 BLK.	
all	16	15G260	HXNUT 1+1/4-7UNC2B BLK GR2	
all	17	15K151	HXCAPSCR 1/2-13UNC2AX1.25 GR5	
all	18	15U300	LOKWASHER REGULAR 1/2 ZINC PLT	
all	19	07 10264	DIAPH POST MTG PLATE	
ABCD	20	07 10258	DIAPHRAGM POSITION PROX.SW POST	
E	20	07 10258A	DIAPHRAGM PROX.SW POST-MP1A03	

Hydraulic Ram and Diaphragm

**MP1540, MP1556, MP1640, MP1656, MP1A56
MPL556, MPL640, MPL656**

**BMP110038/2021055A
(7 / 8)**

Parts List—Hydraulic Ram and Diaphragm

Find the correct assembly first, then find the needed components. The item letters (A, B, C, etc.) assigned to assemblies are referred to in the "Used In" column to identify which components belong to an assembly. The item numbers (1, 2, 3, etc.) assigned to components relate the parts list to the illustration.

Used In	Item	Part Number	Description	Comments
all	21	07 10265	DIAPHRAGM PROX.SW PLATE	
all	22	07 10265A	DIAPHRAGM PROX.SW PL 2"W	
ABC	23	X7 10504	RAM BOLT 1-14X5"CHASED THREAD	
DE	23	X7 10505	RAM BOLT 1-14X7"CHASED THREAD	
all	24	15U393	FLTWASH 1" HARD ASTM F436	
all	25	20C510	LOCTITE MOLYPASTE#51048	
ABCD	26	15K234B	HXCAPSCR 3/4-16UNFX3+1/2" GR8	
E	26	15K234C	HXCAPSCR 3/4-16UNFX5+1/2" GR8	
all	27	15U321H	FLTWASH 3/4 HARD ASTM F436	
ABCD	28	15K303	HEXCAPSCR 1-14X4 GR8 ZINC	
E	28	15K300A	HEXCAPSCR 1-14X5.5 GR8 ZINC 14TPI	
ABCD	29	15N230	FLTHDSOKSCR 3/8-16UNC 4"LG SS	
E	29	15N231	FLTHDSOKSCR 3/8-16UNC 5"LG SS	
all	30	15K136S	HEXCAPSCR 3/8-16 X 3.5 SS18-8	
AB	31	07 10674	DIAPHRAGM PLATE SPACER-MP15XX	
CD	31	07 10673	DIAPHRAGM PLATE SPACER-MP16XX	
E	31	07 10675	DIAPHRAGM PLATE SPACER-MP1AXX	
all	32	52PY0GR002	HEXPLUG 3/8"XOR#6-P50N-SS	
all	33	17N070AP	RETAIN NUT#S10222-27	
all	34	02 11942	H20 BRKT JAM PLATE 36/42QU	
all	35	15U240	FLATWASHER(USS STD) 3/8" ZNC P	
all	36	15U255	LOCKWASHER MEDIUM 3/8 ZINCPL	
all	37	15K095	HXCPCSCR 3/8-16UNC2AX1 GR5 ZINC	
all	38	51E509NA	ELB90 HOSEADPT 1/2HX3/8T NYL	
all	39	5SCC0GBE	NPT COUP 3/8 BRASS 125# 103A-C	
all	40	52AY0GR007	MPADPT.3/8"XOR#6-3/8F50F-SS316	
all	45	07 10237	SHIM=RAM SEAL-.050	
ABCD	46	60E076B078	HOSE ASSY 1/4"X78"LG+ENDS	
E	46	60E076B108	HOSE ASSY 1/4"X108"LG+ENDS	
all	47	52AY0ER008	STR.1/4"MJIC X MP #2404-4-4	
all	48	52ZN1AS003	TUBEFIT NUT+CAP #16-FNL-S	
all	49	52ZT1AS003	TUBEFIT TEE 1" PARKER#16 R6LO-S	
all	50	52ZC1AS002	TUBEFITLGSTRTHDCON 1"#16 FF5OLO-S	
all	51	52ZJ1AS002	TUBEFIT90ELSWNT1" #16 C6LO-S	
all	52	87Z1X095	TUBE 1"ODX.095WL 304SMLS *	
all	53	52ZN1AS001	TUBEFIT 1"NUT #16-BL-S	
AB	54	AHT10030	MEMBRANE SAFETY BAR-MP1603	
CD	54	AHT10030A	MEMBRANE SAFETY BAR-MP1604	
E	54	AHT10030B	DIAPHM SAFETY BAR ASSY-MP1A03	
all	55	20C013B	GASKET ELIMINATOR LOC.#51580	
all	56	15Q125A	GRUB SCREW NYLON 1-8X5/8	
ABC	57	27E161439C	CRC SEAL KIT #SK-2140	
D	57	27E161639C	CRC SEAL KIT FOR REBUILT HSI 27E161639	
E	57	27E161749C	CRC SEAL KIT #SK-2305	

Hydraulic Ram and Diaphragm

**MP1540, MP1556, MP1640, MP1656, MP1A56
MPL556, MPL640, MPL656**

**BMP110038/2021055A
(8 / 8)**

Parts List—Hydraulic Ram and Diaphragm

Find the correct assembly first, then find the needed components. The item letters (A, B, C, etc.) assigned to assemblies are referred to in the "Used In" column to identify which components belong to an assembly. The item numbers (1, 2, 3, etc.) assigned to components relate the parts list to the illustration.

Used In	Item	Part Number	Description	Comments
ABC	58	27E167022A	FAB VEE PACK 13 INCH ID X.5 INCH FOR 27E161439	
D	58	27E167032A	FAB VEE PACK 15 INCH ID X .5 INCH FOR 27E161639	
E	58	27E167736A	FAB VEE PACK 15.5 INCH ID X .5 INCH FOR 27E161749	
	H12		FOR HYDRAULIC HOSE, SEE BMP200015.	

Ratchet Mechanism to Turn the Diaphragm—Components and Adjustment

1. Component Identification

Figure 1: Thrust Arm Assembly

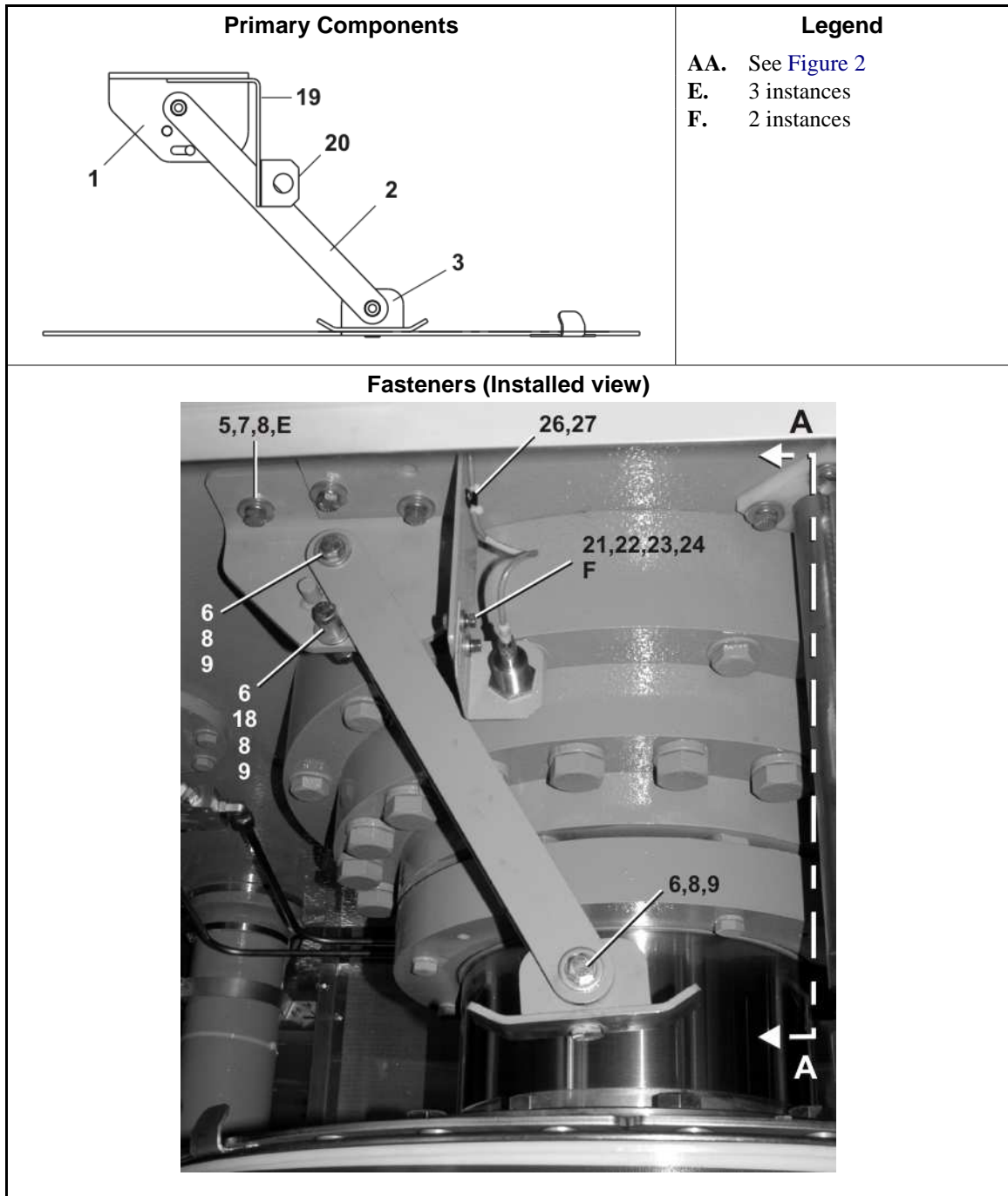

Figure 2: Thrust Arm Assembly—Detailed views

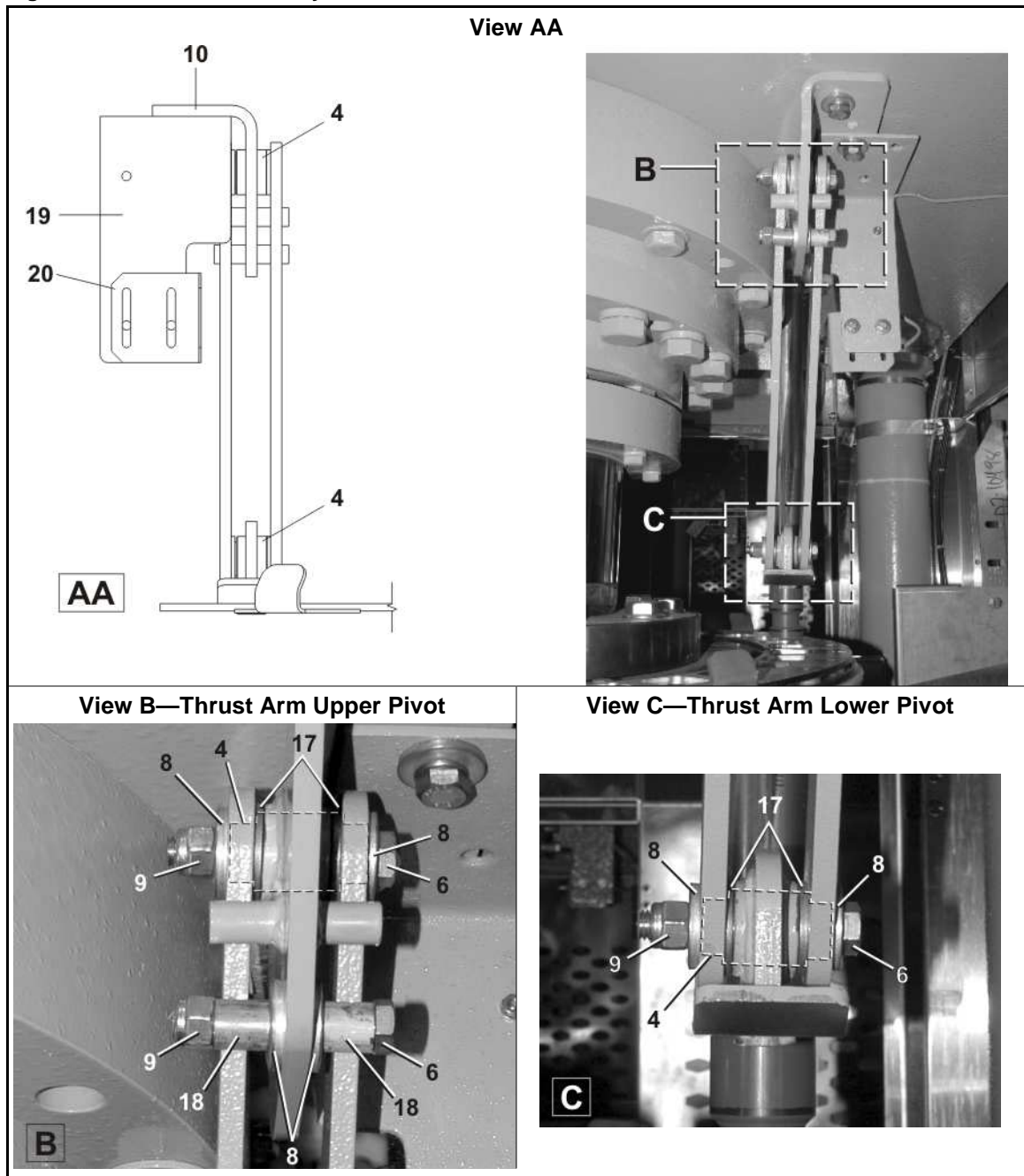

Figure 3: Ratchet Plate

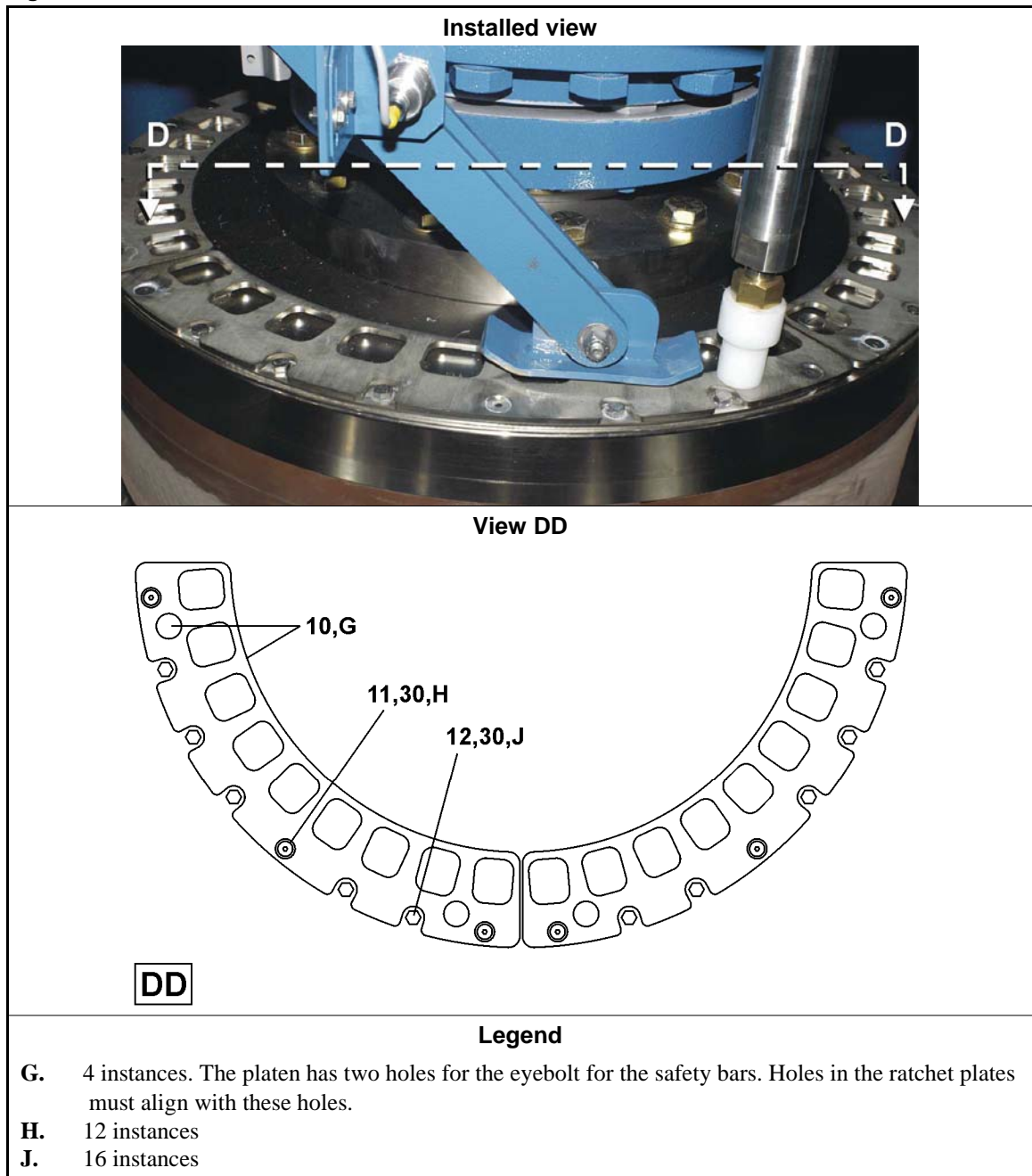

Figure 4: Switch Operation Rod

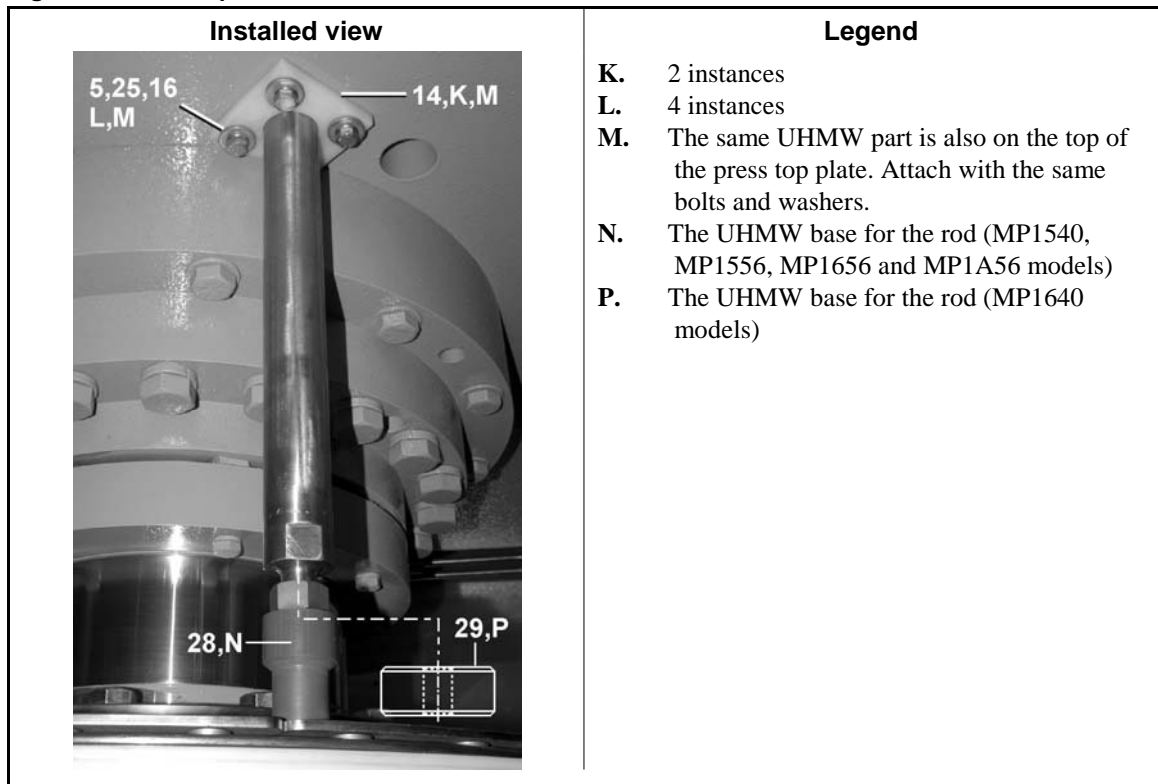

Table 1: Parts List—

Find the assembly for your machine and the letter shown in the "Item" column. The components for your machine will show this letter or the word "all" in the "Used In" column. The numbers shown in the "Item" column are those shown in the illustrations.				
Used In	Item	Part Number	Description/Nomenclature	Comments
Assemblies				
	A	ACW10052	DIAPHRGM ROTATE DEVICE-MP1550	MP1540, MP1556
	B	ACW10051	DIAPHRGM ROTATE DEVICE-MP1603	MP1640
	C	ACW10050	DIAPHRGM ROTATE DEVICE-MP1604	MP1656
	D	ACW10053	DIAPHRGM ROTATE DEVICE-MP1A03	MP1A56
Components				
A	1	W7 10572A	THRUSTARM PIVOT WLMT-MP1550	
B,C,D	1	W7 10572	THRUSTARM PIVOT BRKT WLMT	
A,B	2	07 10573A	DIAPHRAGM THRUST ARM 16IN	
C	2	07 10573	DIAPHRAM THRUST ARM 18IN	
D	2	07 10603	DIAPHRAGM THRUST ARM-MP1A03	
all	3	W7 10574	DIAPHRAGM DRIVE PIN WLMT	
all	4	X7 10578	THRUSTARM PIVOT SHAFT	
all	5	15K153	HXCAPSCR 1/2 -13 X 1 +1/4 SS	
all	6	15K196	HEXCAPSCR 1/2-13UNC2X3 18-8SS	
all	7	15U310	LOKWASHER REGULAR 1/2 SS18-8	
all	8	15U310S	FLATWASH-SS .53 X 1.37 .187T	
all	9	15G234NS	HXLOCKNUT NYL 1/2-13UNC2 SS18-	
A	10	07 10571A	DIAPHRAGM ROTATING PL-MP1550	
B,C	10	07 10571	DIAPHRAGM ROTATING PLATE	
D	10	07 10602	DIAPHRAGM ROTATING PLATE-MP1A03	
A,B,C	11	15N230	FLTHDSOKSCR 3/8-16UNC 4"LG SS	
D	11	15N231	FLTHDSOKSCR 3/8-16UNC 5"LG SS	
all	12	15K136S	HEXCAPSCR 3/8-16x3.5 SS18-8	
all	14	07 10581	DIAPHRAGM ROD LOWER GUIDE	
all	16	27B34010SS	SPACERROLL .51ID.625L.062T SS	
all	17	5.4E+49	THRUSTBRG 1X1.5X1/8 BG#TB1624	
all	18	07 10582	SPACER 3/4"OD X.095 WALL X.75L	
all	19	07 10586	RAM UP PROX.SW BRKT	
all	20	07 10337	RECEIVING CHUTE SW MTG BRKT	
all	21	15N186	HXCAPSCR 1/4-20X3/4 SS18-8	
all	22	15G170	HEXNUT 1/4-20UNC2 SS18-8	
all	23	15U188	FLTWASH 1/4 STD COMM SS18-8	
all	24	15U181	LOCKWASHER MEDIUM 1/4 SS18-8	
all	25	15U285	FLATWASHER 1/2 STD COMM SS18-8	
all	26	15P010	TRDCUT PHILPANHDSCR 10-24X1/2S	
all	27	12P014GG	CAB.CLP.NON-METAL 3/8ID,3/8W	
A,C,D	28	X7 10250	GUIDE ROD UHMW BASE	
B	29	X7 10250A	DIAPHRAGM ROD BASE-MP1603	
all	30	20C510	LOCTITE MOLYPASTE#51048 ANTI-SEIZE	

2. The Stop Adjustment for the Ratchet Mechanism



WARNING 1: Risk of death or severe injury—The container and ram move independently. During operation, these components move without warning. These components can also move down with power off. Spaces can close and cut off your arm.

- Keep personnel not necessary for this maintenance clear of the machine.
- Use special caution when you use the key that bypasses the door guards for maintenance.

The pin on the bottom of the ratchet arm must fall in the center of a hole in the ratchet turn plate each time the platen goes up. You adjust this with the stop bolt (Figure 5, Item 1) which you can move right or left in its slot, then tighten. You will use the Manual mode in this procedure. Each time that you move the ram up and down, you must move it up fully to simulate the automatic operation of the press. This is necessary to get the correct adjustment of the ratchet arm.

1. Put the stop bolt at the center of the slot and tighten it. This will let the arm have moderate movement.
2. Use the Manual mode. Move the ram up fully. Move the ram down until the turn plate is approximately two inches (50 mm) below the bottom of the ratchet arm. The first time that you do this, it is possible that the pin on the ratchet arm will not be aligned with a hole. This step will align the holes in the turn plate with the pin.
3. Look at the position of the pin on the ratchet arm and the hole it will go in. If the pin will not go in the center of the hole, refer to Figure 5. Adjust the stop bolt as follows:
 - Move the bolt to the right for less movement of the arm. The pin will go in the hole near the front edge (the edge that the pin pushes).
 - Move the bolt to the left for more movement of the arm. The pin will go in the hole near the rear edge (the edge the pin moves away from).
4. Do steps 2 and 3 again until you get the correct adjustment.
5. Move the ram up and down continuously until the diaphragm makes one full turn to make sure that the adjustment is correct.

Figure 5: Where to Adjust the Thrust Arm

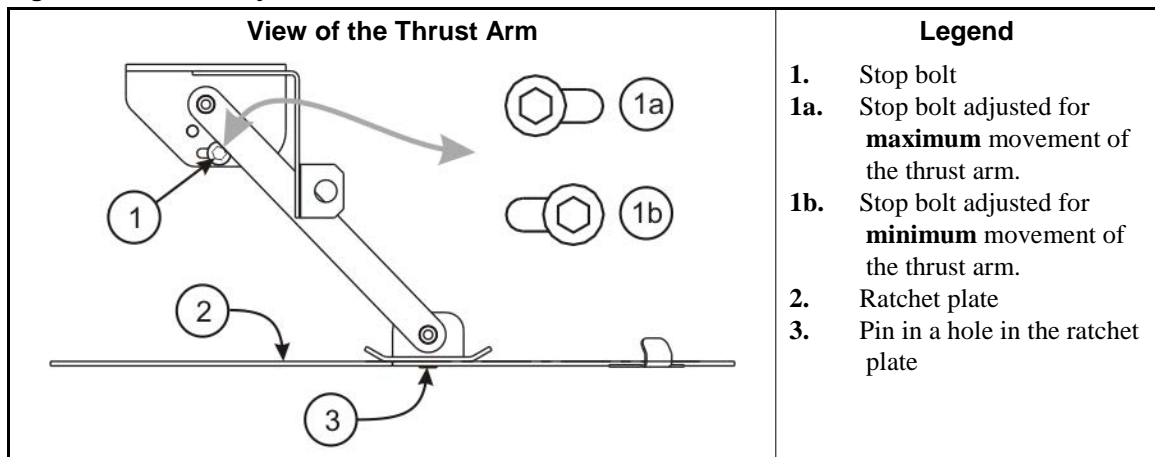

— End of BIPPM22 —

Load Chute Scupper with Adjustable Seal

MP1540, MP1556, MP1640, MP1656, MP1A50
MPL556, MPL640, MPL656

BMP160024/2020275A
(1 / 5)



Pellerin Milnor Corporation
P. O. Box 400, Kenner, LA 70063-0400

Litho in U.S.A.

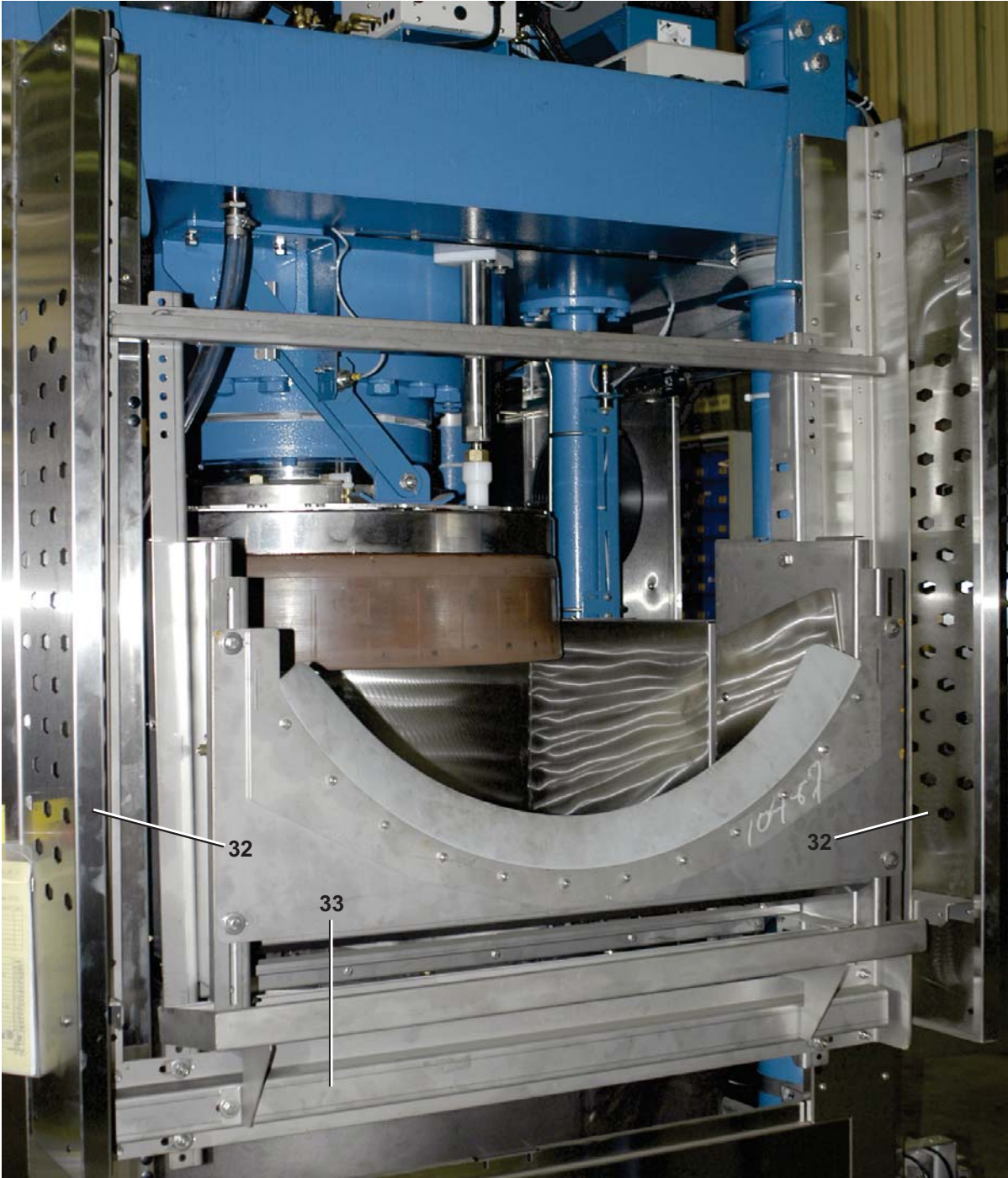

Load Chute Scupper with Adjustable Seal

MP1540, MP1556, MP1640, MP1656, MP1A50
MPL556, MPL640, MPL656

BMP160024/2020275A
(2 / 5)



Pellerin Milnor Corporation
P. O. Box 400, Kenner, LA 70063-0400

Litho in U.S.A.

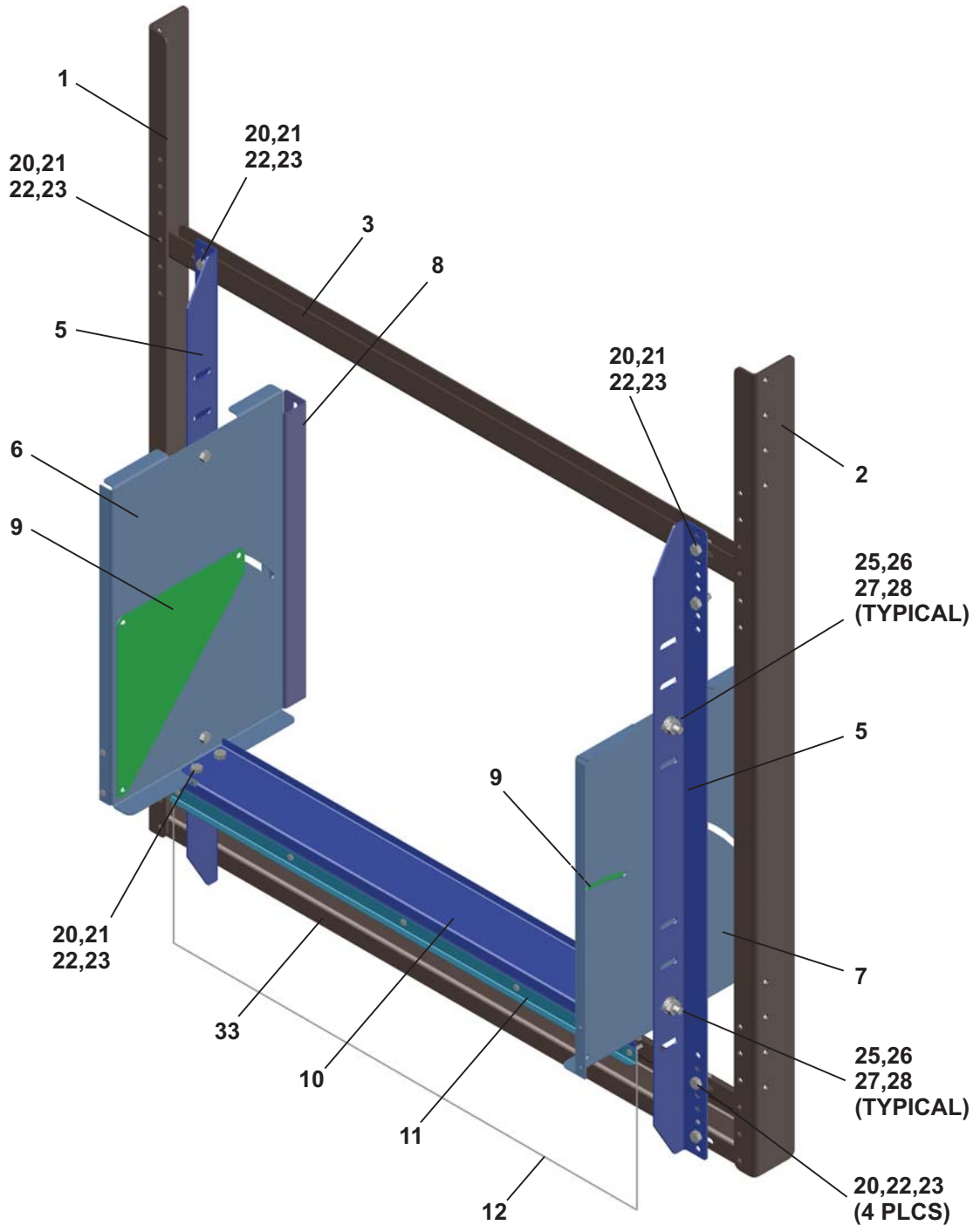

Load Chute Scupper Frame

Load Chute Scupper with Adjustable Seal

MP1540, MP1556, MP1640, MP1656, MP1A50
MPL556, MPL640, MPL656

BMP160024/2020275A
(3 / 5)



Pellerin Milnor Corporation
P. O. Box 400, Kenner, LA 70063-0400

Litho in U.S.A.

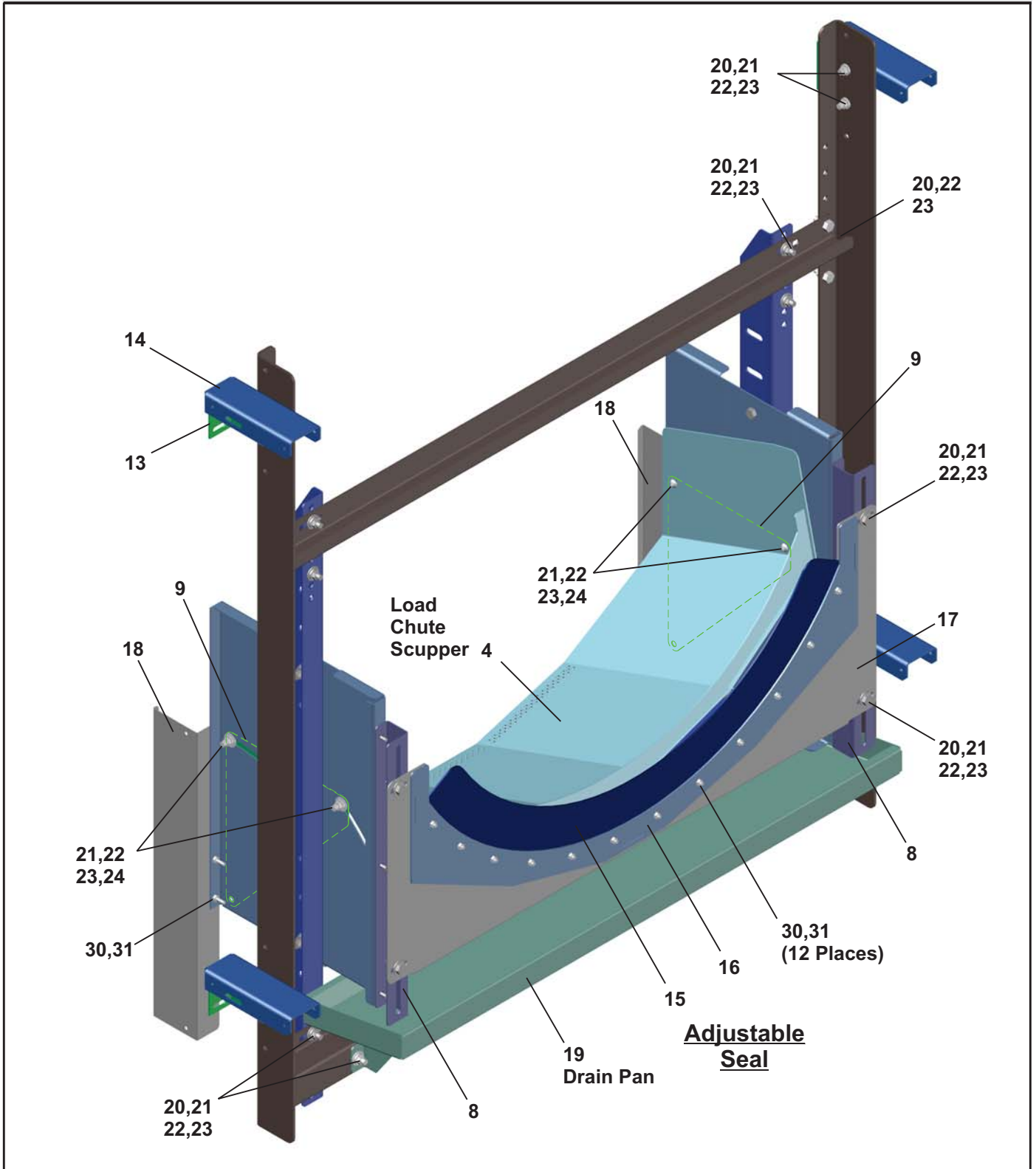

Load Chute Scupper with Adjustable Seal

**MP1540, MP1556, MP1640, MP1656, MP1A50
MPL556, MPL640, MPL656**

**BMP160024/2020275A
(4 / 5)**

Parts List—Scupper Load Chute

Find the correct assembly first, then find the needed components. The item letters (A, B, C, etc.) assigned to assemblies are referred to in the "Used In" column to identify which components belong to an assembly. The item numbers (1, 2, 3, etc.) assigned to components relate the parts list to the illustration.

Used In	Item	Part Number	Description	Comments
			-----ASSEMBLIES-----	
	A	ACS10009A	ENTRY CHUTE W/ADJUSTABLE SEAL-MP16XX	
			-----COMPONENTS-----	
all	1	07 10328	CHUTE DRAIN FRAME-RIGHT	
all	2	07 10328A	CHUTE DRAIN FRAME-LEFT	
all	3	07 10478	ENTRY CHUTE 40W TOP CHAN	
all	4	W7 10703	OUTSIDE LOADCHUTE WLMT-40W	
all	5	07 10498	ENTRY CHUTE MTG ANGLE-MP16XX	
all	6	07 10458	ENTRY CHUTE MTG BRKT-RT	
all	7	07 10458A	ENTRY CHUTE MTG BRKT-LF	
all	8	07 10708	LOADCHUTE SEAL MTG BRKT	
all	9	07 10460	CHUTE ANGLE ADJ PLATE	
all	10	07 10489	PLASTIC SHEET MTG ANGLE-40W	
all	11	07 10332	PLASTIC SHEET MTG STRIP	
all	12	54C241CP	PLASTIC SHT .080X24" EA.=1FT	
all	13	07 10015	LDCHUTE MOUNTING BRKT-SSPRESS	
all	14	07 10017	LOADCHUTE GUARD MTG BRKT	
all	15	07 10486	LOADCHUTE SPLASH GUARD	
all	16	07 10487	ENTRY CHUTE 40W END PLATE	
all	17	07 10707	LOADCHUTE SEAL MTG PANEL	
all	18	07 10684	LOAD CHUTE SIDE PANNEL	
all	19	W7 10706	LDCHUTE DRAIN PAN WLMT	
all	20	15K086	HXCAPSCR 3/8-16NCX3/4 SS18-8	
all	21	15U245A	FLTWASH 25/64IDX1.25ODX3/32 S/	
all	22	15U260	LOCKWASHER MEDIUM 3/8 SS18-8	
all	23	15G206	HEXNUT 3/8-16 UNC2 SS 18-8	
all	24	15K083V	BUTSOKCAPSCR 3/8-16X3/4 SS18-8	
all	25	15K153	HXCAPSCR 1/2 -13 X 1 +1/4 SS	
all	26	15U310S	FLATWASH-SS .53 X 1.37 .187T	
all	27	15U310	LOKWASHER REGULAR 1/2 SS18-8	
all	28	15G234B	HEXNUT 1/2-13UNC2B BRASS	

Load Chute Scupper with Adjustable Seal

**MP1540, MP1556, MP1640, MP1656, MP1A50
MPL556, MPL640, MPL656**

**BMP160024/2020275A
(5 / 5)**

Parts List—Scupper Load Chute

Find the correct assembly first, then find the needed components. The item letters (A, B, C, etc.) assigned to assemblies are referred to in the "Used In" column to identify which components belong to an assembly. The item numbers (1, 2, 3, etc.) assigned to components relate the parts list to the illustration.

Used In	Item	Part Number	Description	Comments
all	29	15U285	FLATWASHER 1/2 STD COMM SS18-8	
all	30	15K041S	HEXCAPSCR 1/4-20UNC2AX1 SS18-8	
all	31	15G164NE	HEXLOKNUT NYL 1/4-20 UNC2A SS	
all	32	07 10018	LOADCHUTE GUARD 7632	
all	33	07 10469	ENTRY CHUTE 40W SUPPORT CHAN	

Receiving Chute and Can

MP1540, MP1566, MP1640, MP1656, MP1A50
MPL566, MPL640, MPL656

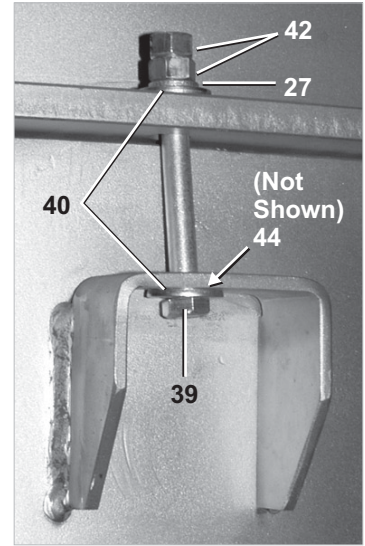
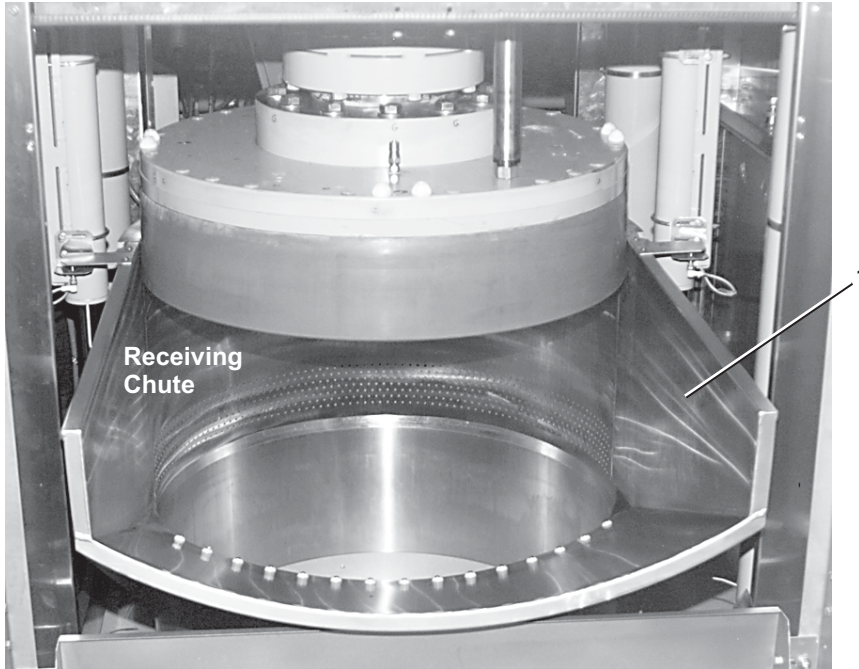

Typical 6 Places

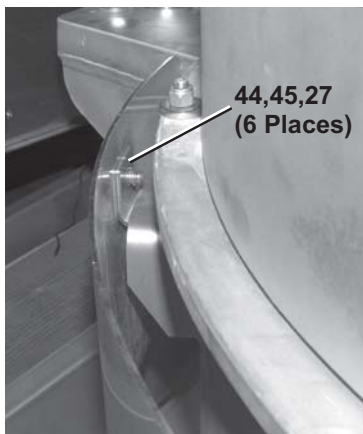
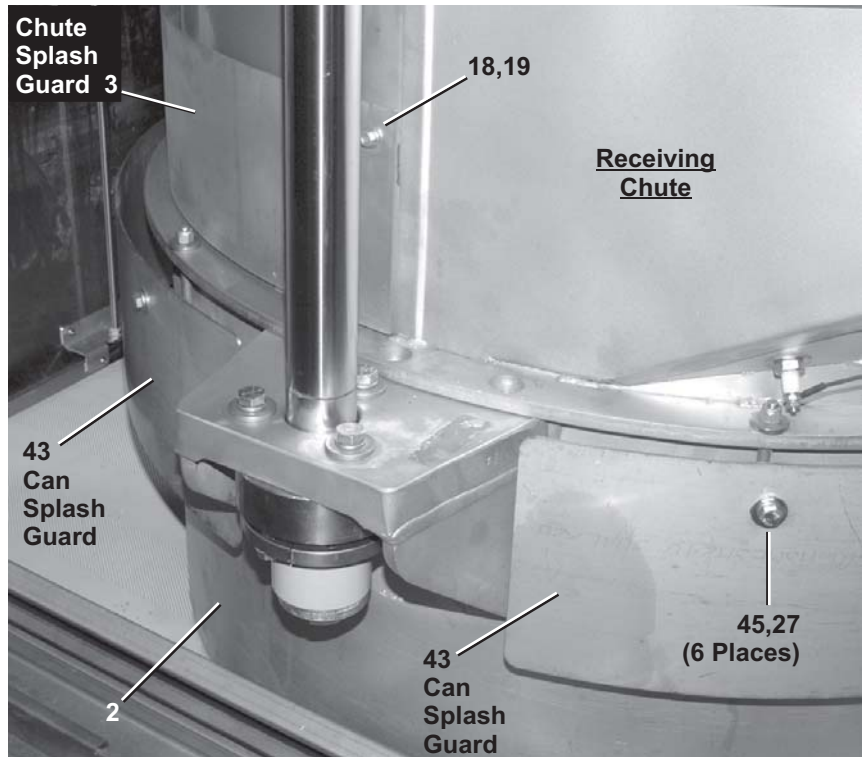

Receiving Chute and Can

MP1540, MP1566, MP1640, MP1656, MP1A50
MPL566, MPL640, MPL656

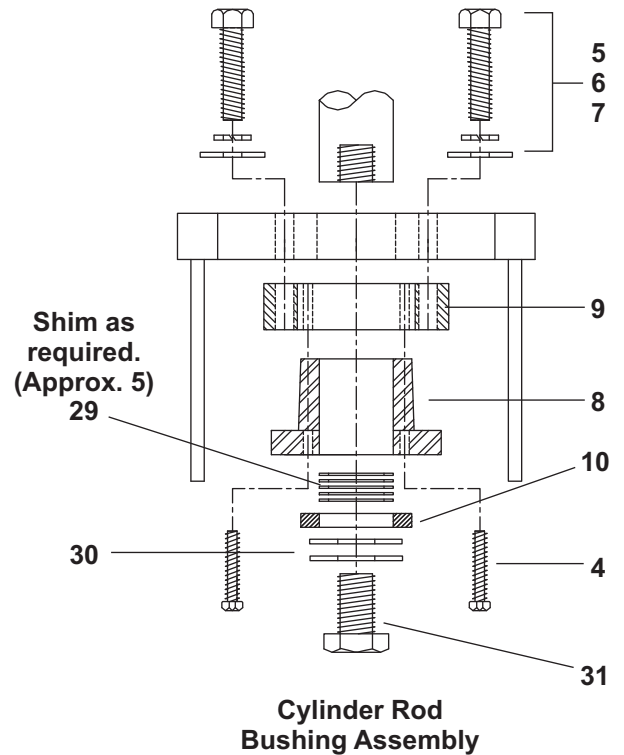
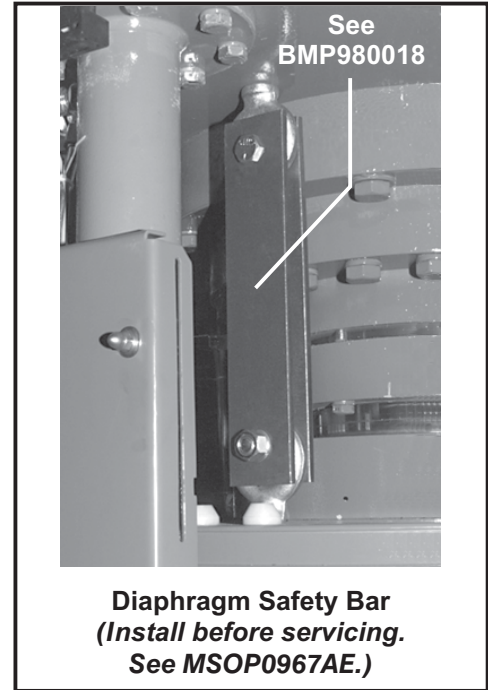
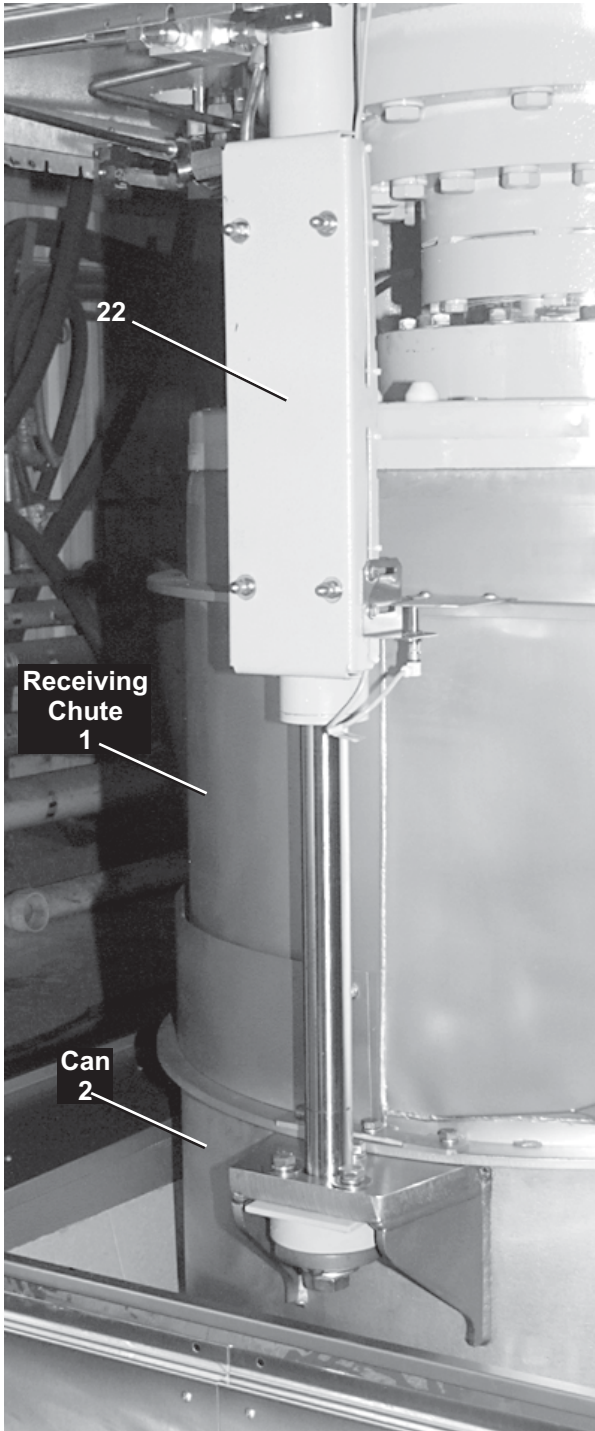

Receiving Chute and Can

MP1540, MP1566, MP1640, MP1656, MP1A50
MPL566, MPL640, MPL656

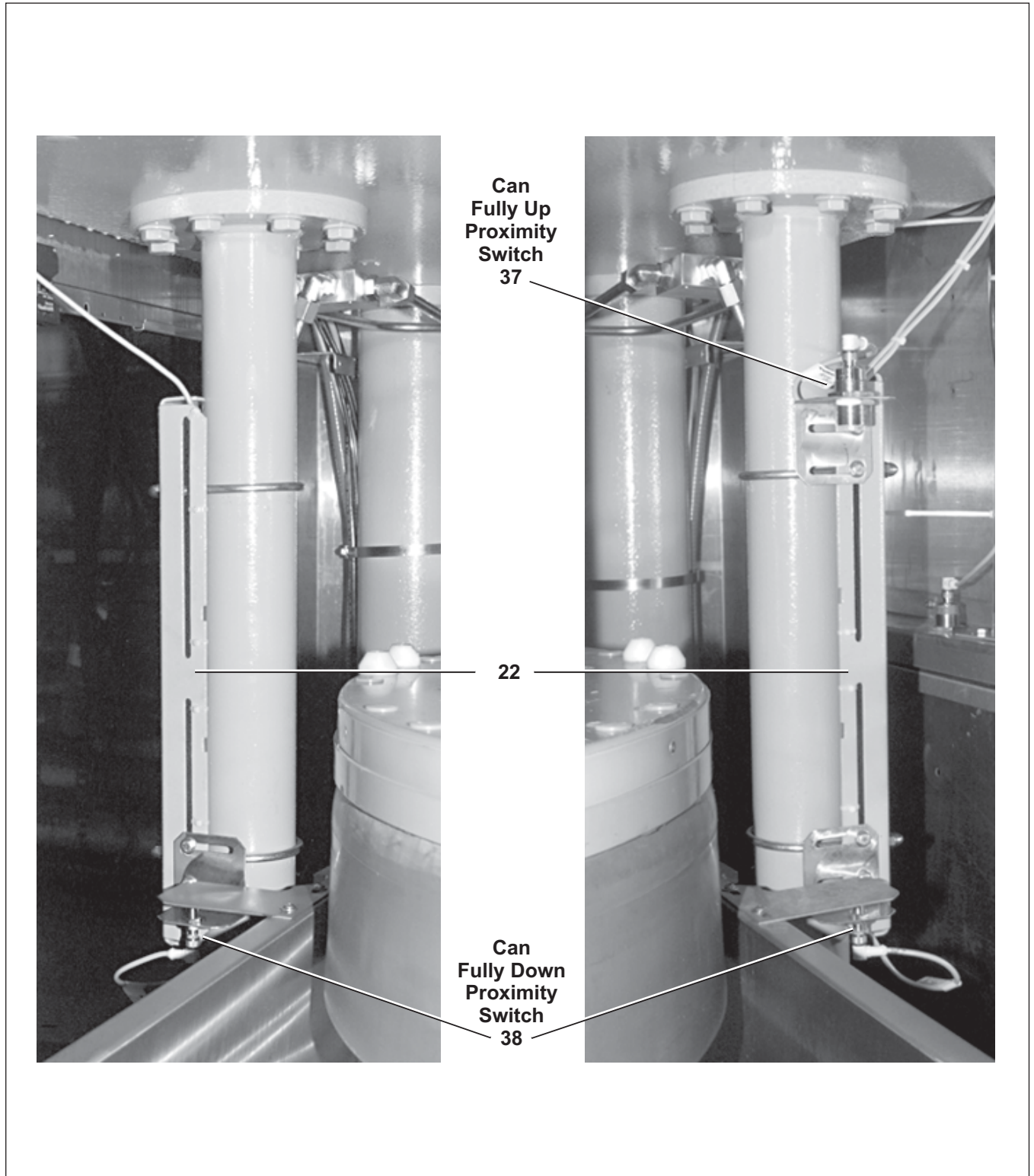

Receiving Chute and Can

MP1540, MP1566, MP1640, MP1656, MP1A50
MPL566, MPL640, MPL656

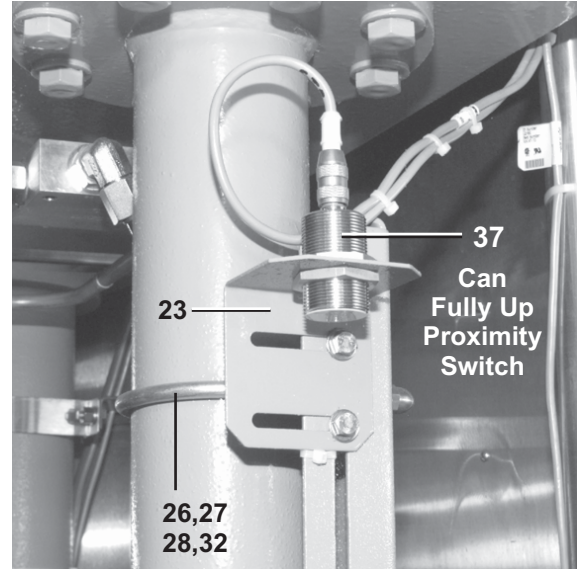
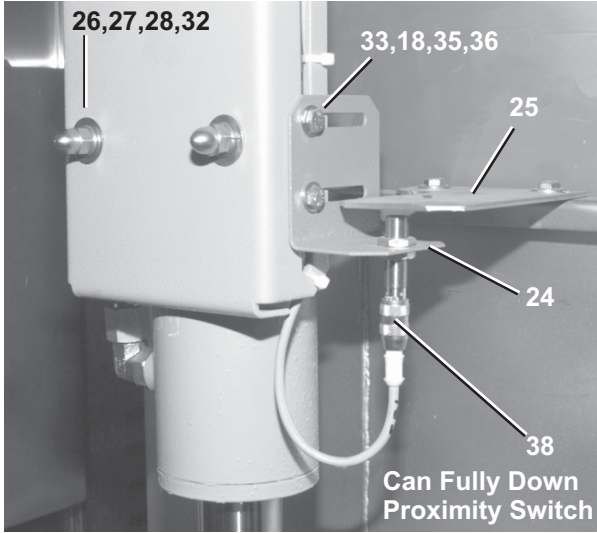

Incomplete Transfer Chute Sensors:



Receiving Chute and Can

MP1540, MP1566, MP1640, MP1656, MP1A50
 MPL566, MPL640, MPL656

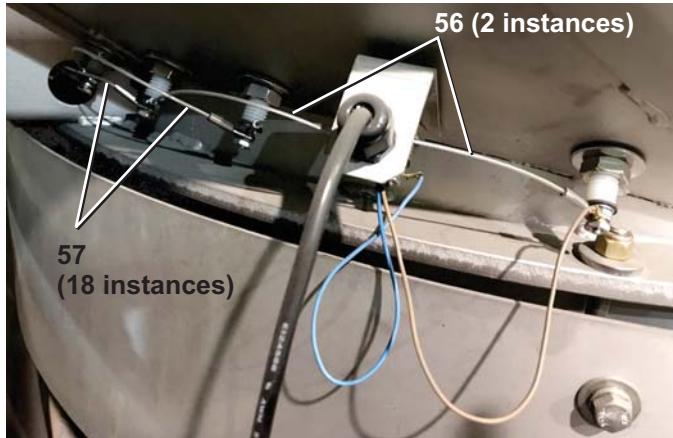

View A-A

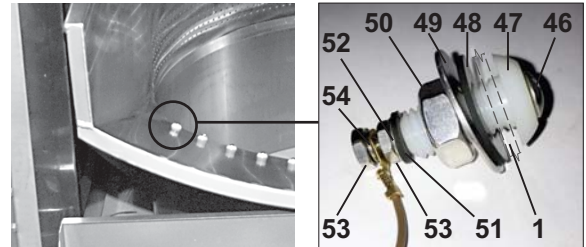

View B-B

Note: Incomplete Transfer Chute Sensors
 Make a closed circuit. Connect every other sensor with nine inch and six inch wires (items 56 and 57) to the furthest point out, as shown. Connect skipped sensors to return to the harness. Make electrical control connections.

Parts List

Find the correct assembly first, then find the needed components. The item letters (A, B, C, etc.) assigned to assemblies are referred to in the "Used In" column to identify which components belong to an assembly. The item numbers (1, 2, 3, etc.) assigned to components relate the parts list to the illustration.

Used In	Item	Part Number	Description	Comments
-----ASSEMBLIES-----				
	A	MP1540B	40 BAR PRESS BASE MODULE	MP1540
	B	MP1556B	MP1556B 56 BAR PRESS BASE MODULE	MP1556, MPL556
	C	MP1640B	MP1640B 40 BAR PRESS BASE MODULE	MP1640, MPL640
	D	MP1656B	MP1656B 56 BAR PRESS BASE MODULE	MP1656, MPL656
	E	MP1A56B	MP1A56 56BAR BASE MODULE	MP1A50
	F	A80CS002	CHUTE SENSOR ASSY-MP1A03	ALL
	G	ECA9B083S	ASSEMBLY FOR SENSOR PRESS	ALL
-----COMPONENTS-----				
AB	1	W7 10518	SSPRESS CHUTE 36"X30DEG WLMT	
CD	1	W7 10468	SSPRESS CHUTE 40WX30DEG WLMT	
E	1	W7 10510	SSPRESS CHUTE 48"X35DEG WLMT	
AB	2	Y7 10064	PRESS 900MMX18.5H CAN-MACHINED	
CD	2	Y7 10026	SSPRESS 18.5H CAN-MACHINED	
E	2	Y7 10032	SSPRESS 48DX22.5H CAN-MACHINED	
AB	3	07 10519	SPLASH GUARD 36DIA CHUTE-ROLLED	
CD	3	07 10306	CHUTE SPLASH GUARD-ROLLED	
E	3	07 10373	SPLASH GUARD 48"CHUTE-ROLLED	

Receiving Chute and Can

MP1540, MP1566, MP1640, MP1656, MP1A50
MPL566, MPL640, MPL656

Parts List

Find the correct assembly first, then find the needed components. The item letters (A, B, C, etc.) assigned to assemblies are referred to in the "Used In" column to identify which components belong to an assembly. The item numbers (1, 2, 3, etc.) assigned to components relate the parts list to the illustration.

Used In	Item	Part Number	Description	Comments
all	4	15K116	HEXFLGSCR 3/8-16X1.75 GR8 ZINC	
all	5	15K191C	HEXCAPSCR 1/2-13X2.5 GR8CHROME	
all	6	15U310	LOKWASHER REGULAR 1/2 SS18-8	
all	7	15U310S	FLATWASH-SS .53 X 1.37 .187T	
all	8	56Q2ASFNIP	2"BUSHING QD TYPE"SF" + PLTG.	
all	9	X7 10111	QD HUB 1.50LG BUSHING	
ABC	10	X7 10051	CAN CYL ROD END SPACER-31BAR	
DE	10	X7 10046	CAN CYL ROD END SPACER-50BAR	
all	18	15U188	FLTWASH 1/4 STD COMM SS18-8	
all	19	15G180	HEXNUT 1/4-20 BRASS	
ABCD	22	07 10360	RECEIVE CHUTE SW CHANNEL	
E	22	07 10384	LOADCHUTE PROX.SW BRKT	
all	23	07 10337	RECEIVING CHUTE SW MTG BRKT	
all	24	07 10337A	CHUTE PROX.SW BRKT-12MM	
all	25	07 10338A	CHUTE TARGET-900MM MEMBRANE	
all	25	07 10338	SSPRESS CHUTE TARGET	
all	26	15U245	FLTWASH 3/8 STD COMM 18-8 SS	
all	27	15U260	LOCKWASHER MEDIUM 3/8 SS18-8	
all	28	27A035	UBOLT 3/8-16 3.625"BETWEN LEGS	
all	29	15U404C	16 GA ADJWASH =BRGHOUS ZINC	
all	30	02 15630	FLATWASH 2.75 X .25+ZINC PLT	
all	31	15K255A	HEXCAPSCR 1-8X1.75 316SS	
all	32	15G221	HEXCASTLENUIT 3/8-16UNC2 SS18-8	
all	33	15N174	HXCAPSCR 1/4-20UNC2X5/8SS18-8	
all	35	15U181	LOCKWASHER MEDIUM 1/4 SS18-8	
all	36	15G170	HEXNUT 1/4-20UNC2 SS18-8	
all	37	09RPS30ADS	PROX SW QK CONN 30M NO-DC SHLD	
AB	38	09RPSDC010	CONN.STR FEMALE DC 3A 300V 10M	
CDE	38	09RPSDC095	CON.90DEG FEMALE DC 3A300V 5M	
all	39	15K227T	HXCAPSCW 3/8-16X3 1/2 TFL S/S	
all	40	15U245A	FLTWASH 25/64IDX1.25ODX3/32 S/	
all	42	15G206	HEXNUT 3/8-16 UNC2 SS 18-8	
AB	43	07 10075	CAN SPLASH GUARD MP1550	
CD	43	07 10072	CAN SPLASH GUARD MP16XX	
E	43	07 10074	CAN SPLASH GUARD MP1A03	

Receiving Chute and Can

MP1540, MP1566, MP1640, MP1656, MP1A50
MPL566, MPL640, MPL656

Parts List

Find the correct assembly first, then find the needed components. The item letters (A, B, C, etc.) assigned to assemblies are referred to in the "Used In" column to identify which components belong to an assembly. The item numbers (1, 2, 3, etc.) assigned to components relate the parts list to the illustration.

Used In	Item	Part Number	Description	Comments
all	44	07 10073	CAN SPLASH GUARD BRKT	
all	45	15K086	HXCAPSCR 3/8-16NCX3/4 SS18-8	
all	45	15K086	HXCAPSCR 3/8-16NCX3/4 SS18-8	
all	46	15N153A	TRUSLTMACCHSCR10-24X1.75 18-8S	
F	47	X7 10322	CHUTE SENSOR NYLON BOLT	
G	48	15U173	FLATWASHER 1/2 VITON - PK = 5 EACH	
F	49	15U285	FLATWASHER 1/2 STD COMM SS18-8	
F	50	15G231S	HXFJNUT 1/2-13UNC2B SS18-8	
G	51	15U132	FLATWASH #10 VITON - PK = 25 EACH	
F	52	15U135	FLATWASH#10 .4370DX.203IDX.04T	
F	53	15G130	HEXMACHSCRNUT 10-24UNC2 SS18-8	
F	54	15U160	LOCKWASHER MEDIUM #10 SS18-8	
F	55	07 10339	SENSOR WIRE CONN BRKT	
G	56	09V300SS09	9" SS WIRE - RING TO RING - COATED	
G	57	09V300SS06	6" SS WIRE - RING TO RING - COATED	

Counterbalance Valves and Tubing

MP1540, MP1556, MP1640, MP1656, MP1A50
MPL556, MPL640, MPL656

BMP110041/2020275A
(1 / 4)



Pellerin Milnor Corporation
P. O. Box 400, Kenner, LA 70063-0400

Litho in U.S.A.

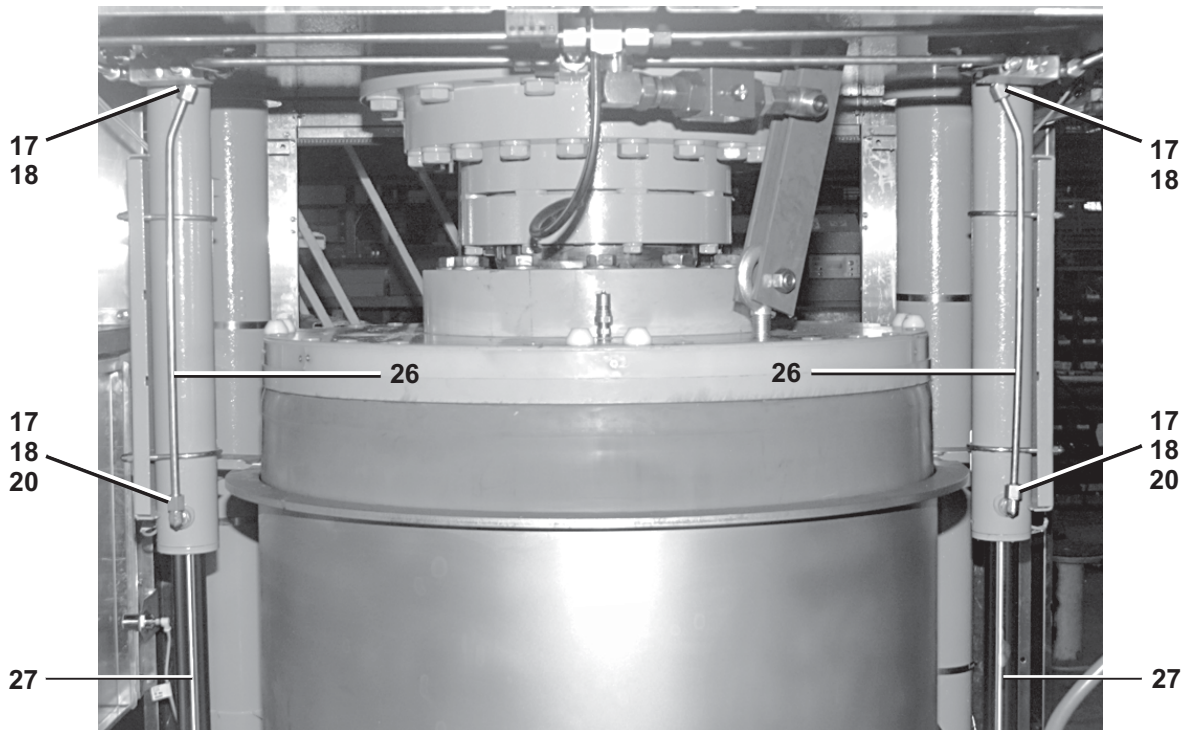
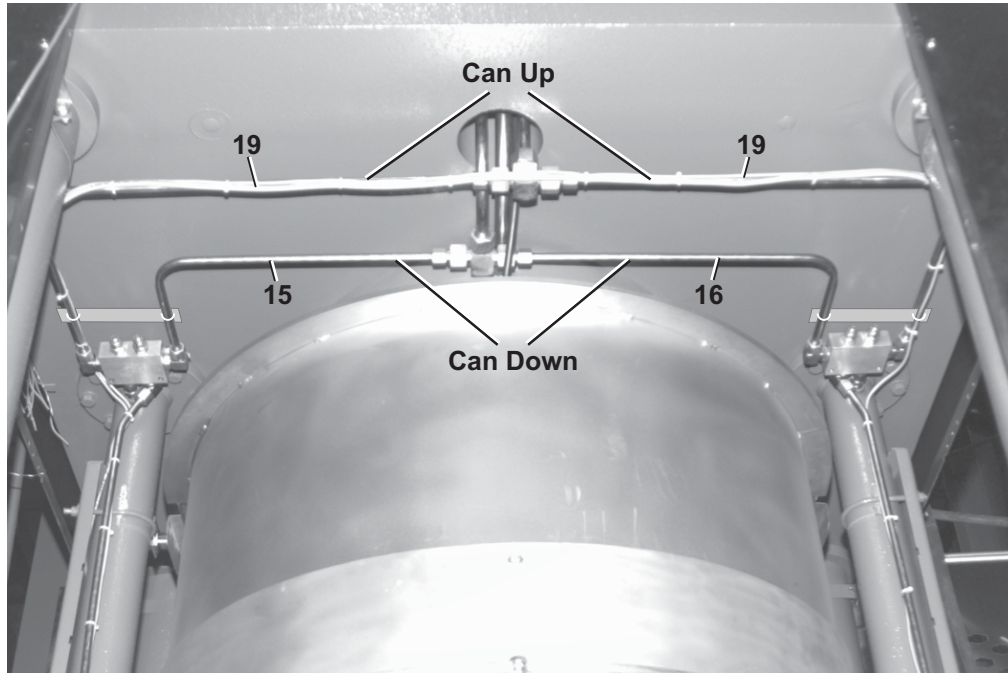

Counterbalance Valves and Tubing

MP1540, MP1556, MP1640, MP1656, MP1A50
MPL556, MPL640, MPL656

BMP110041/2020275A
(2 / 4)



Pellerin Milnor Corporation
P. O. Box 400, Kenner, LA 70063-0400

Litho in U.S.A.

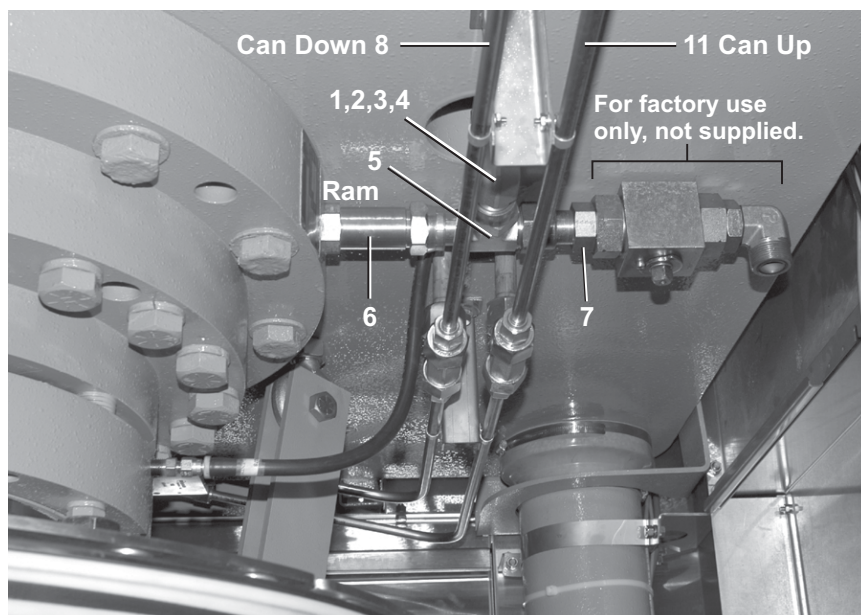
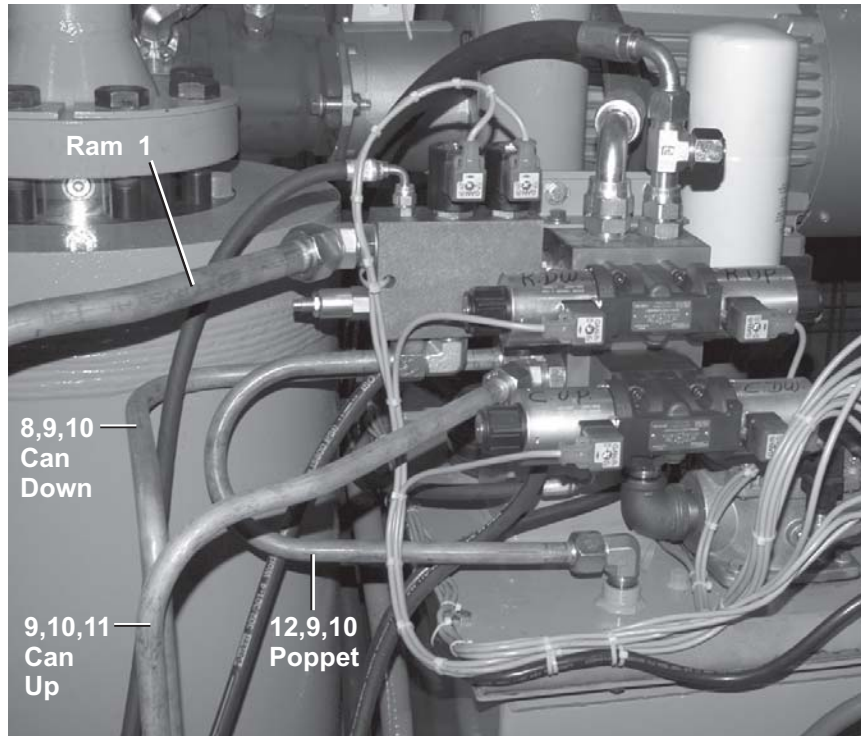

Counterbalance Valves and Tubing

MP1540, MP1556, MP1640, MP1656, MP1A50
MPL556, MPL640, MPL656

BMP110041/2020275A
(3 / 4)



Pellerin Milnor Corporation
P. O. Box 400, Kenner, LA 70063-0400

Litho in U.S.A.

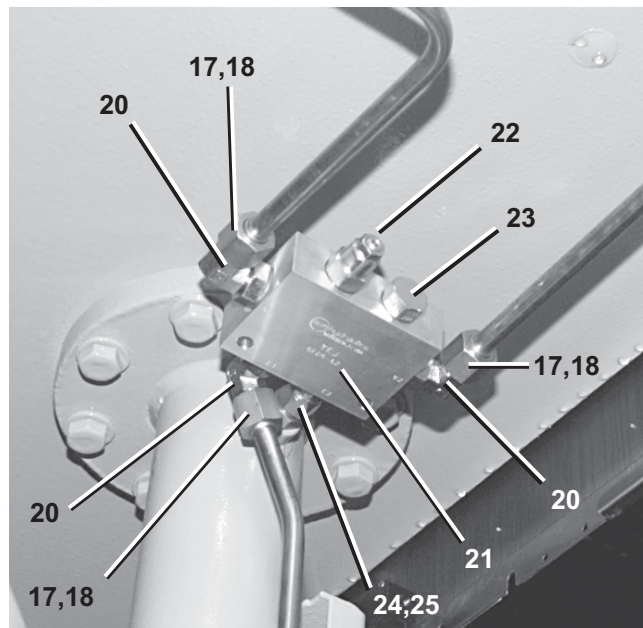
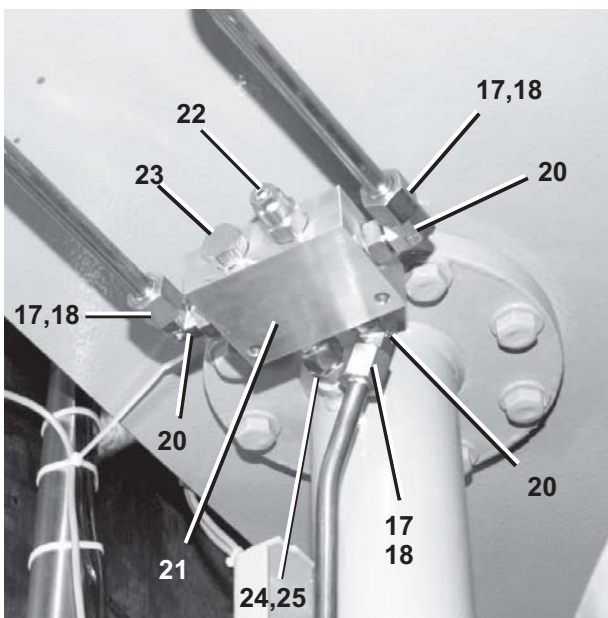
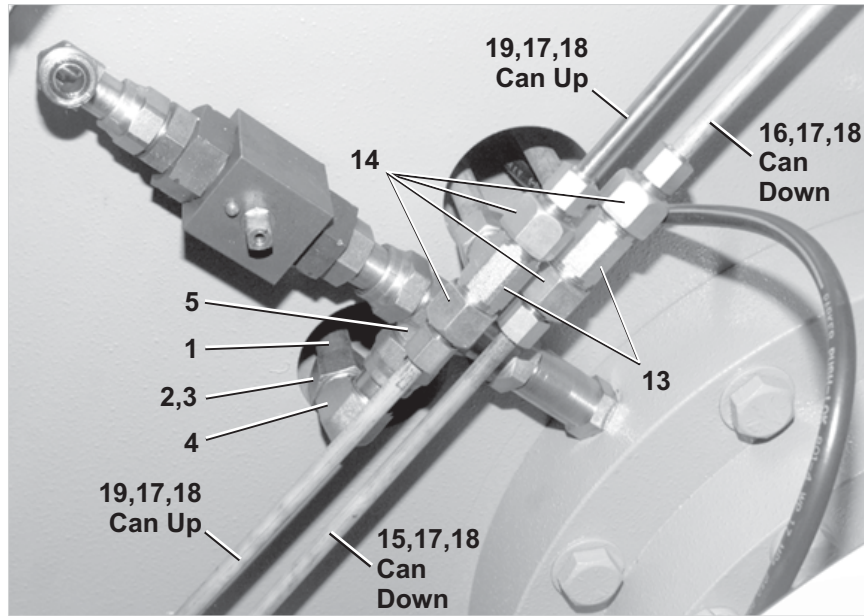

Counterbalance Valves and Tubing

**MP1540, MP1556, MP1640, MP1656, MP1A50
MPL556, MPL640, MPL656**

**BMP110041/2020275A
(4 / 4)**



Pellerin Milnor Corporation
P. O. Box 400, Kenner, LA 70063-0400

Litho in U.S.A.

Parts List—Counterbalance Valves and Tubing

Find the correct assembly first, then find the needed components. The item letters (A, B, C, etc.) assigned to assemblies are referred to in the "Used In" column to identify which components belong to an assembly. The item numbers (1, 2, 3, etc.) assigned to components relate the parts list to the illustration.

Used In	Item	Part Number	Description	Comments
-----ASSEMBLIES-----				
	A	A80CC001	CAN CYL-COUNTERBAL ASSY	MP1540, MP1556, MP1640, MP1656
	B	A80CC005	CAN CYL-COUNTERBAL ASSY-MP1A03	MP1A50
	C	AHT10015	TUBINGS FOR MP1540/1550/1603	MP1540, MP1556, MP1640
	D	AHT10016	TUBINGS FOR MP/1556/1640	MP1656, MP1A50
-----COMPONENTS-----				
C	1	07 10646C	TUBING RAM UP-MP1540	MP1540
C	1	07 10646A	TUBING-RAM UP-MP1556/1640	MP1556, MP1640
D	1	07 10646	TUBING RAM UP-MP1656	MP1656
D	1	07 10646B	TUBING-RAM UP-MP1AXX	MP1A50
all	2	52ZN1AS001	TUBEFIT 1"NUT #16-BL-S	
all	3	52ZN1AS002	TUBEFIT 1"SLEEVE #16-TPL-STAINLESS	
all	4	52ZJ1AS002	TUBEFIT90ELSWNT1"#16-C6LO-S	
all	5	52ZT1AS003	TUBEFTTEE 1"PARKER#16R6L0-S	
all	6	52ZC00S008	TUBEFITSTRTHDCON 1"#16-F50L0	
all	7	52ZN1AS003	TUBEFIT NUT+CAP #16-FNL-S	
all	8A	07 10645	TUBING-CAN DOWN	MP1656
all	9	52ZN0PS001	TUBEFIT 3/4"NUT #12BL-S	
all	10	52ZN0PS002	TUBEFIT 3/4"SLEEVE #12-TPL-STAINLESS	
all	11A	07 10644	TUBING-CAN UP	MP1656
all	12	07 10643	TUBING-POPET VAL MANF RETURN	
all	13	52ZT00S002	TUBEFIT 3/4TEE #12-JLO-S	
all	14	52ZL00S008	TUBEFITRED3/4X1/2#12-8TRL0N-S	
all	15	07 10648	TUBING-C'BAL CAN DOWN-SHORT	
all	16	07 10649	TUBING-C'BAL CAN DOWN LONG	
all	17	52ZN00S004	TUBEFIT 1/2"NUT FCSL#8-BL-S	
all	18	52ZN00S005	TUBEFIT 1/2"PARF.SLEEVE#8TPL-S	
all	19	07 10650	TUBING-C'BAL CAN UP	
all	20	52ZJ00S003	TUBEFIT1/2"90ELFC#8-C50LO-S	
all	21	96DH471	COUNTERBALANCE VALVE-SUN BODY	
all	22	96DH471A	CARTRIDGE-COUNTERBAL.SUN	
all	23	96DH410	CART., SUN CHECKVALVE CKCB-XCN	
all	24	52XY0KR032	STRADPT 1/2MJICX0R#6400-8-8-0	
all	25	52XY0KR034	STRADPT 1/2MORXFJIC#6402-8-8-0	
all	26	07 10647	TUBING-CANCLY CAN UP PORT	
All	27	27E163A17A	HYD.CYL 3.25"BORE X 16.25"STK	MP1540,MP1640 MP1556,MP1656
all	27	27E163A20A	HYD.CYL.3.25"BORE X 20.25"STK.	MP1A50

Pneumatic Piping and Assemblies

3

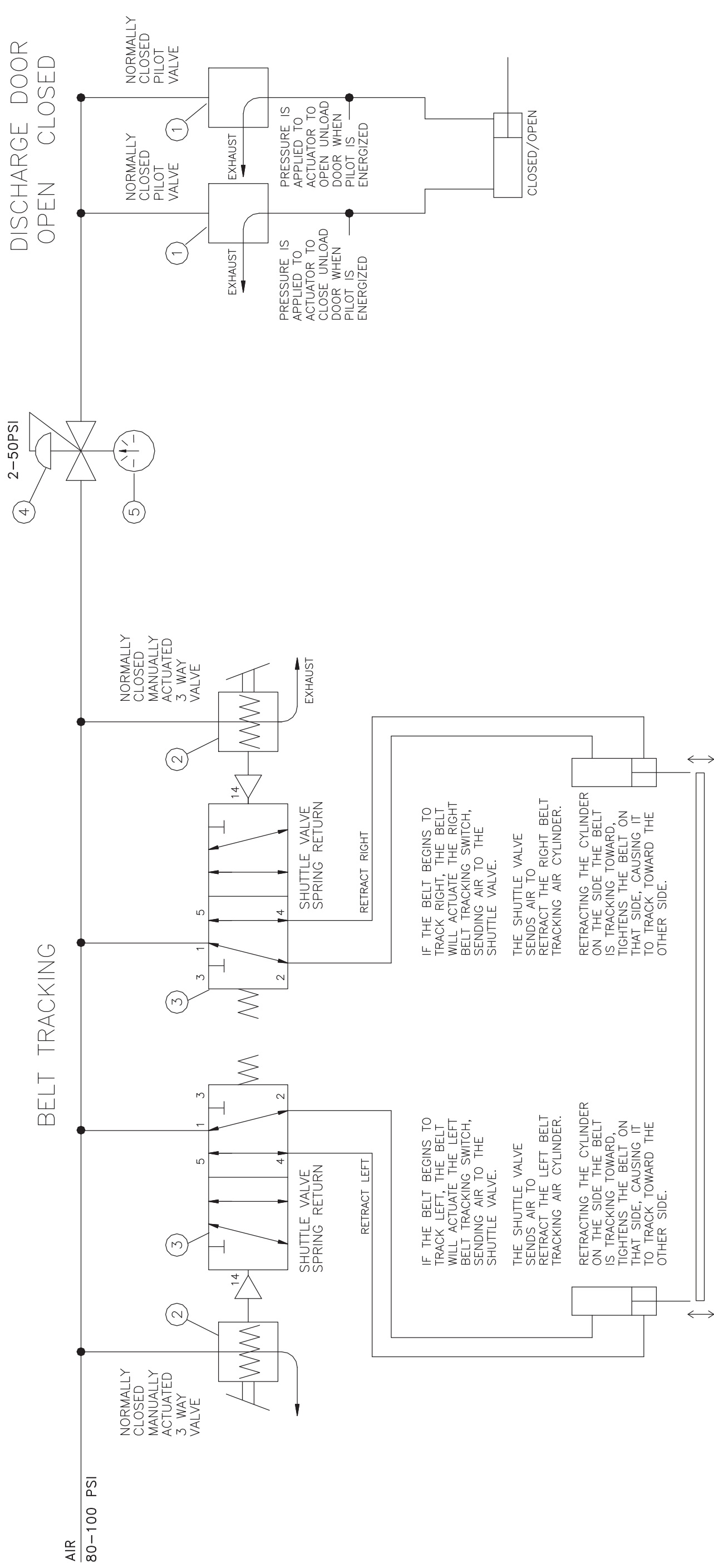

Pneumatic Schematic
MP1540, MP1556, MP1640, MP1656, MP1A50
MPL550/556, MPL640/650/656

BMP110042/2020275B
 (2 / 2)



Pellerin Milnor Corporation
 P. O. Box 400, Kenner, LA 70063-0400

Litho in U.S.A.

Used In	Item	Part Number	Description	Comments
			-----COMPONENTS-----	
all	1	96R301B37	1/8" AIRPILOT 3W NC 120V50/60	
all	2	96N005	3WAY AIROP CONT.VLV.CLIPP#MJV3	
all	3	96N0011H	SHUTLVLV 1/4" 4WAY MECHSPRING	
all	4	96J019E	1/4"PRESSREG2-50P R07-200-RNEA	
all	5	30N101	PRESSGAUGE 1/8"BACKCN.0-60PSI	

Parts List—Pneumatic Schematic

Find the correct assembly first, then find the needed components. The item letters (A, B, C, etc.) assigned to assemblies are referred to in the "Used In" column to identify which components belong to an assembly. The item numbers (1, 2, 3, etc.) assigned to components relate the parts list to the illustration.

Conveyor Assemblies

4

Conveyor Bed
MP1540, MP1556, MP1640, MP1656, MP1A50, MPL1556, MPL640, MPL656

BMP110018/2020275B
 (1/2)



Pellerin Milnor Corporation
 P. O. Box 400, Kenner, LA 70063-0400

Litho in U.S.A.

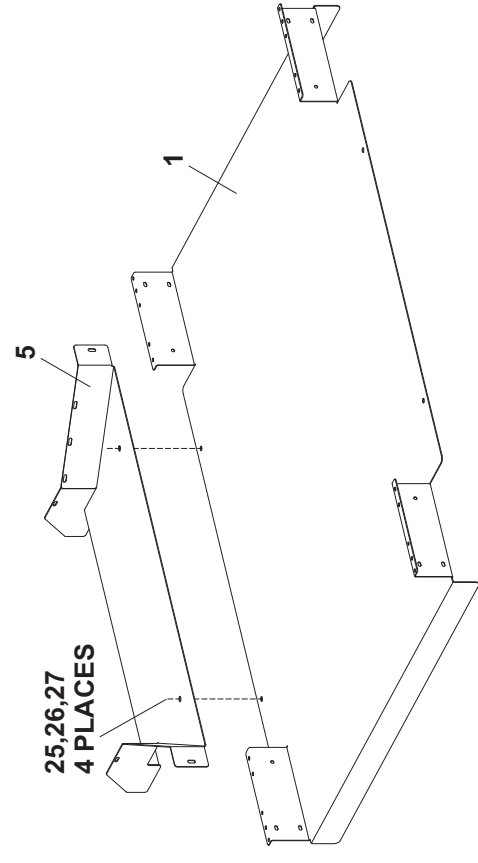
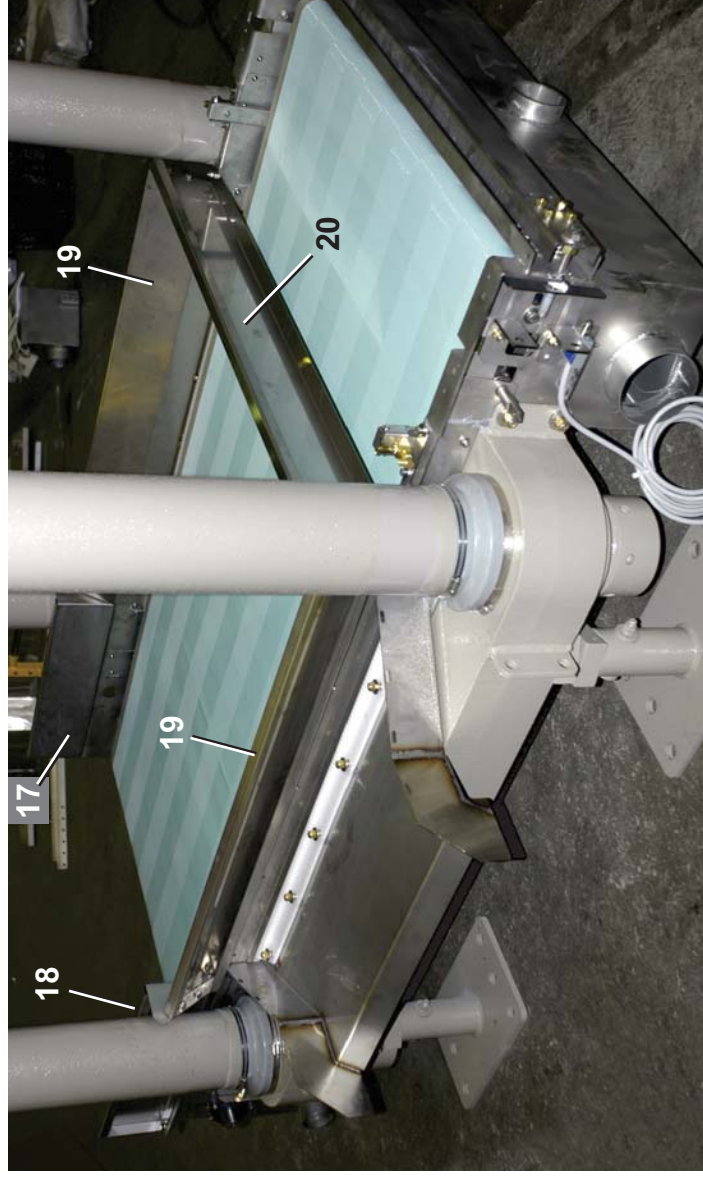
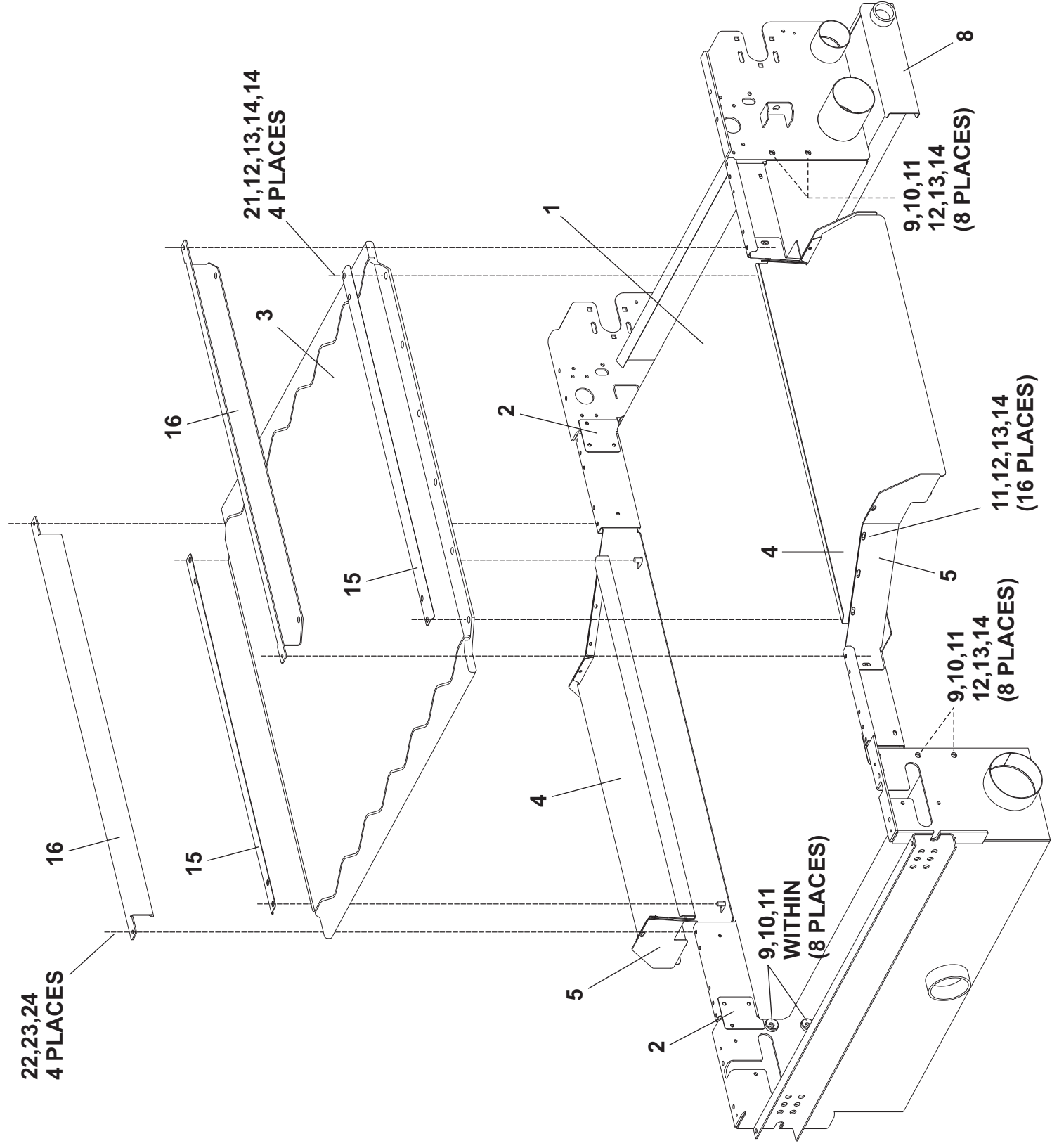

Detail: Bed liner and extension

Conveyor Bed
MP1540, MP1556, MP1640, MP1656, MP1A50, MPL556, MPL640, MPL656

BMP110018/2020275B
 (2 / 2)



Pellerin Milnor Corporation
 P. O. Box 400, Kenner, LA 70063-0400

Litho in U.S.A.

Parts List—Conveyor Bed
 Find the correct assembly first, then find the needed components. The item letters (A, B, C, etc.) assigned to assemblies are referred to in the "Used In" column to identify which components belong to an assembly. The item numbers (1, 2, 3, etc.) assigned to components relate the parts list to the illustration.

Used In	Item	Part Number	Description	Comments
	A	ALC420164	CONV SIDE ASSY-MP16XX	
			-----ASSEMBLIES-----	
			-----COMPONENTS-----	
all	1	W4 24091	CONV BED 42W WLMT-MP16XX	
all	2	04 23508	BED END SEAL PLATE	
all	3	03 80010F	PRESS BED Z-GRV R/L DRAIN-MP16XX	
all	4	04 23620	BED EXT. SPLASH GUARD	
all	5	W4 23536A	CONV BED LINER EXTENSION WLMT	
all	6	04 21460	BELT HOLD DOWN BRKT-RT	
all	7	04 21460A	BELT HOLD DOWN BRKT-LF	
all	8	ALC420114	DRIP TRAY UNLOADEND-31BAR	
all	9	07 20607N	MK2 "O"RING RET PRE-PRESS	
all	10	60C108	ORING 1/2IDX3/16CS BUNA70#310	
all	11	15K180S	HXCAPSCR 1/2-13UNCAX2 18-8SS	
all	12	15U310S	FLATWASH-SS .53 X 1.37 .187T	
all	13	15U310	LOKWASHER REGULAR 1/2 SS18-8	
all	14	15G234B	HEXNUT 1/2-13UNC2B BRASS	
all	15	04 24213	PLASTIC BED HOLD DOWN STRIP	
all	16	04 24215	PLASTIC BED HOLD DOWN CHANNEL	
all	17	04 23505	SIDE UNLOAD END SSPRESS-RT	
all	18	04 23505A	SIDE UNLOAD END SSPRESS-LF	
all	19	04 23512	BED SIDE MIDDLE SECTION	
all	20	04 23513	CONV ENDGATE-MP16XX	
all	21	15K171	HEXCAPSCR 1/2-13UNC2X1+3/4 SS1	
all	22	15K052	HXCAPSCR 5/16-18UNC2AX3/4 SS18	
all	23	15U205	LOCKWASHER MEDIUM 5/16" 18-8SS	
all	24	15G186	HEXNUT 5/16-18UNC2 SS18-8	
all	25	15K086	HXCAPSCR 3/8-16NCX3/4 SS18-8	
all	26	24G030N	ROLLED WASH.379ID NYLTITE 37W	
all	27	15U245A	FLTWASH 25/64IDX1.25ODX3/32 S/	



Conveyor Unload End Assemblies
MP1540, MP1556, MP1640, MP1656, MP1A50, MPL556, MPL640, MPL656

BMP110010/2020275B
 (1 / 8)



Pellerin Milnor Corporation
 P. O. Box 400, Kenner, LA 70063-0400

Litho in U.S.A.

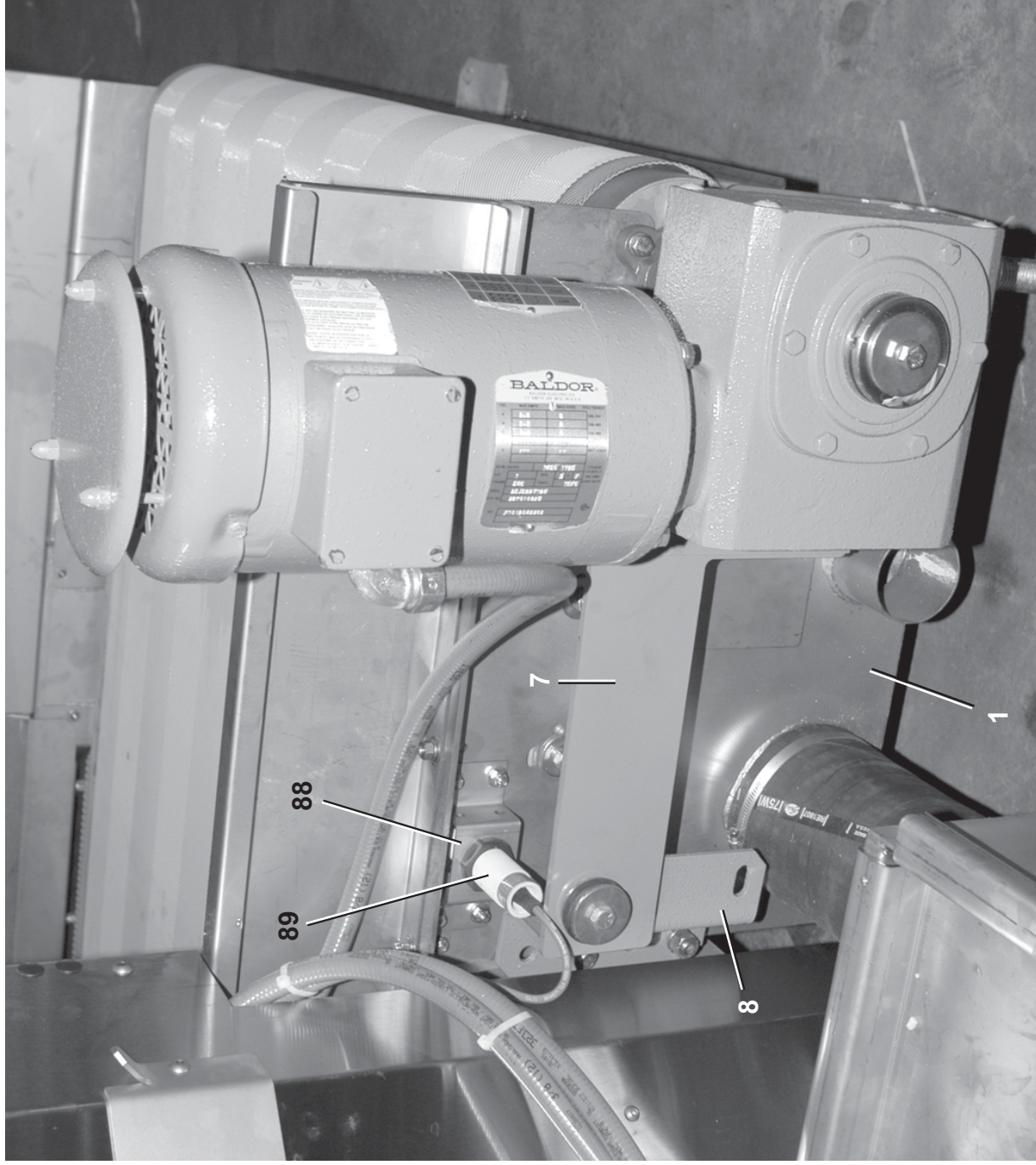

**Conveyor Unload End - 0" Bed Extension
 (00A, 00B)**

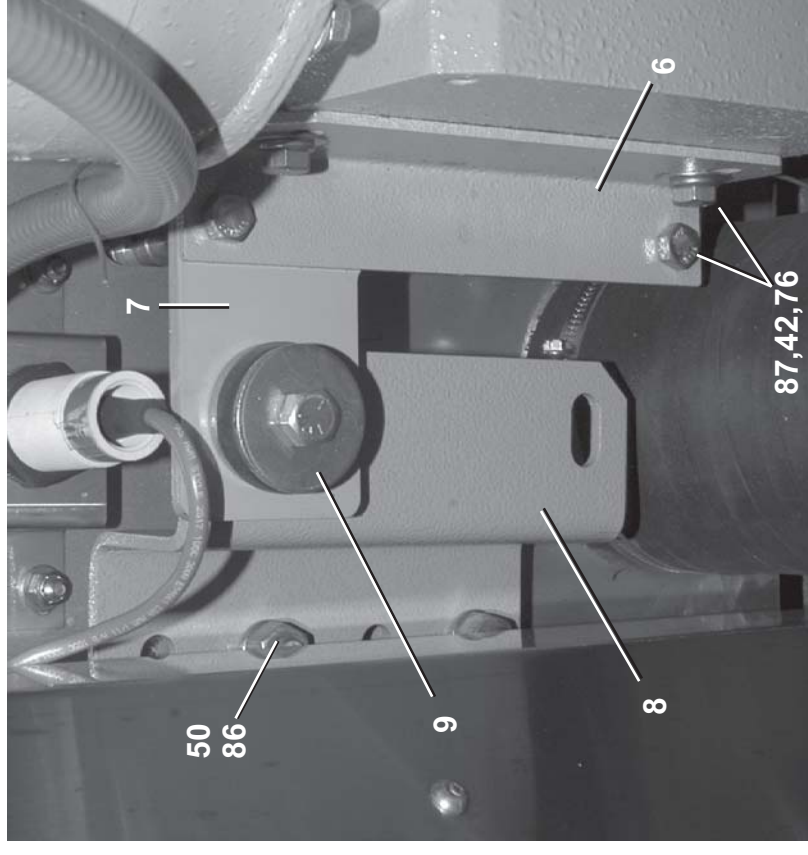

Torque Arm

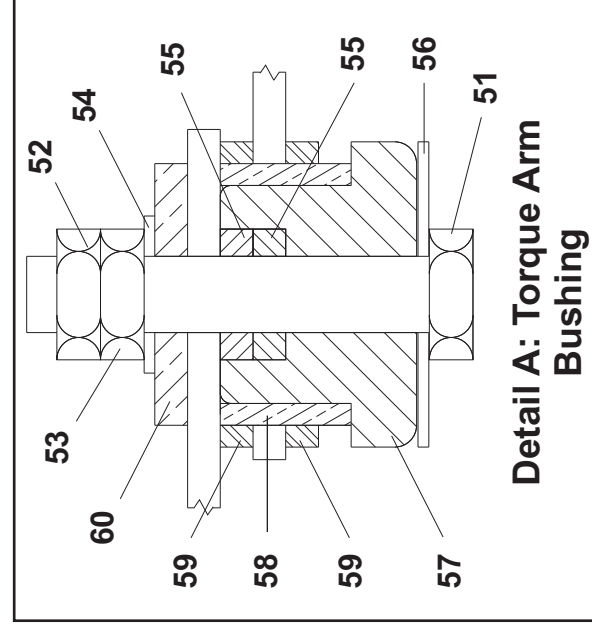

**Detail A: Torque Arm
 Bushing**

Conveyor Unload End Assemblies
MP1540, MP1556, MP1640, MP1656, MP1A50, MPL556, MPL640, MPL656

BMP110010/2020275B
 (2 / 8)

MILNOR
 Pellerin Milnor Corporation
 P. O. Box 400, Kenner, LA 70063-0400

Litho in U.S.A.

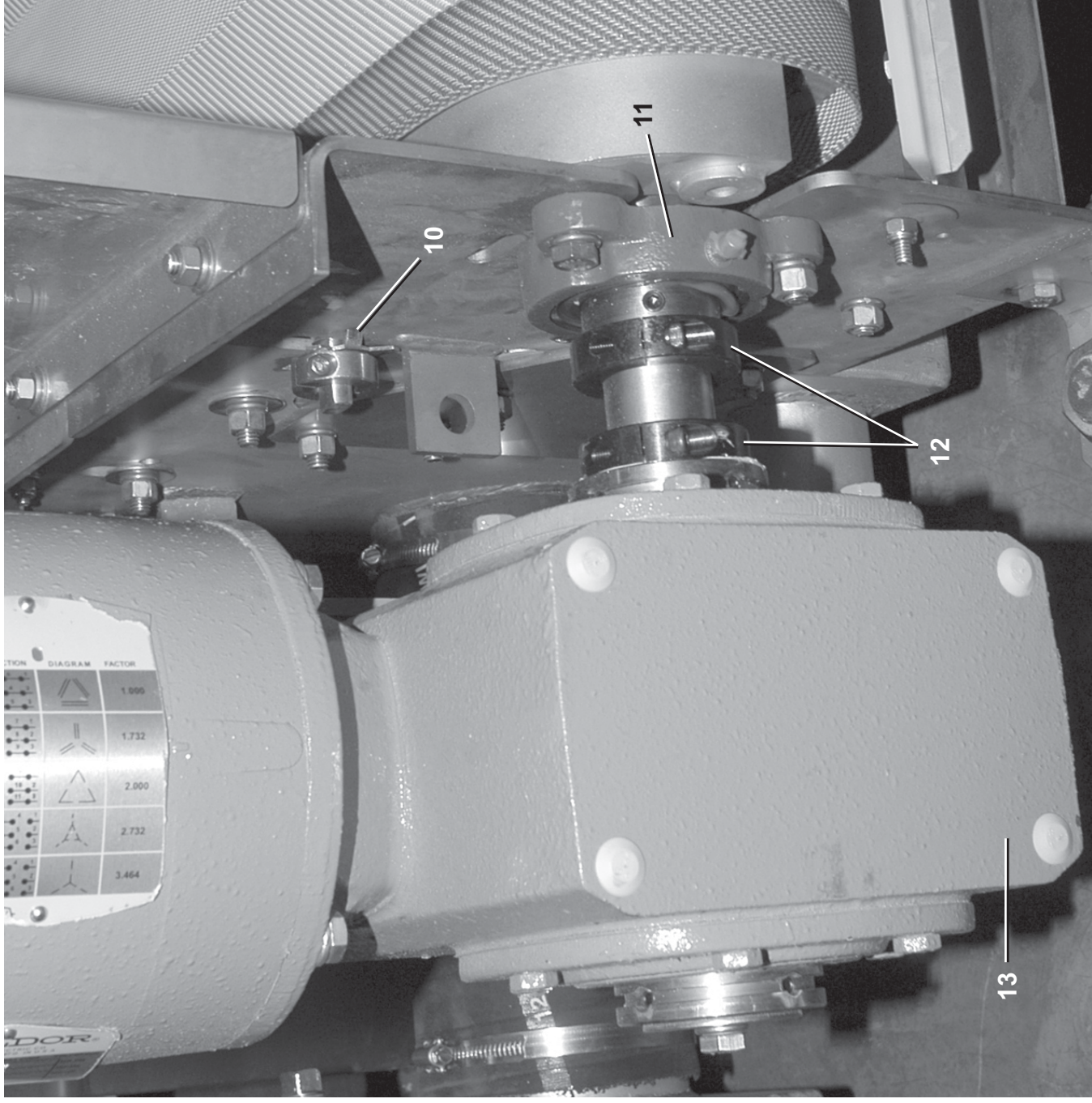

Conveyor Unload End Drive

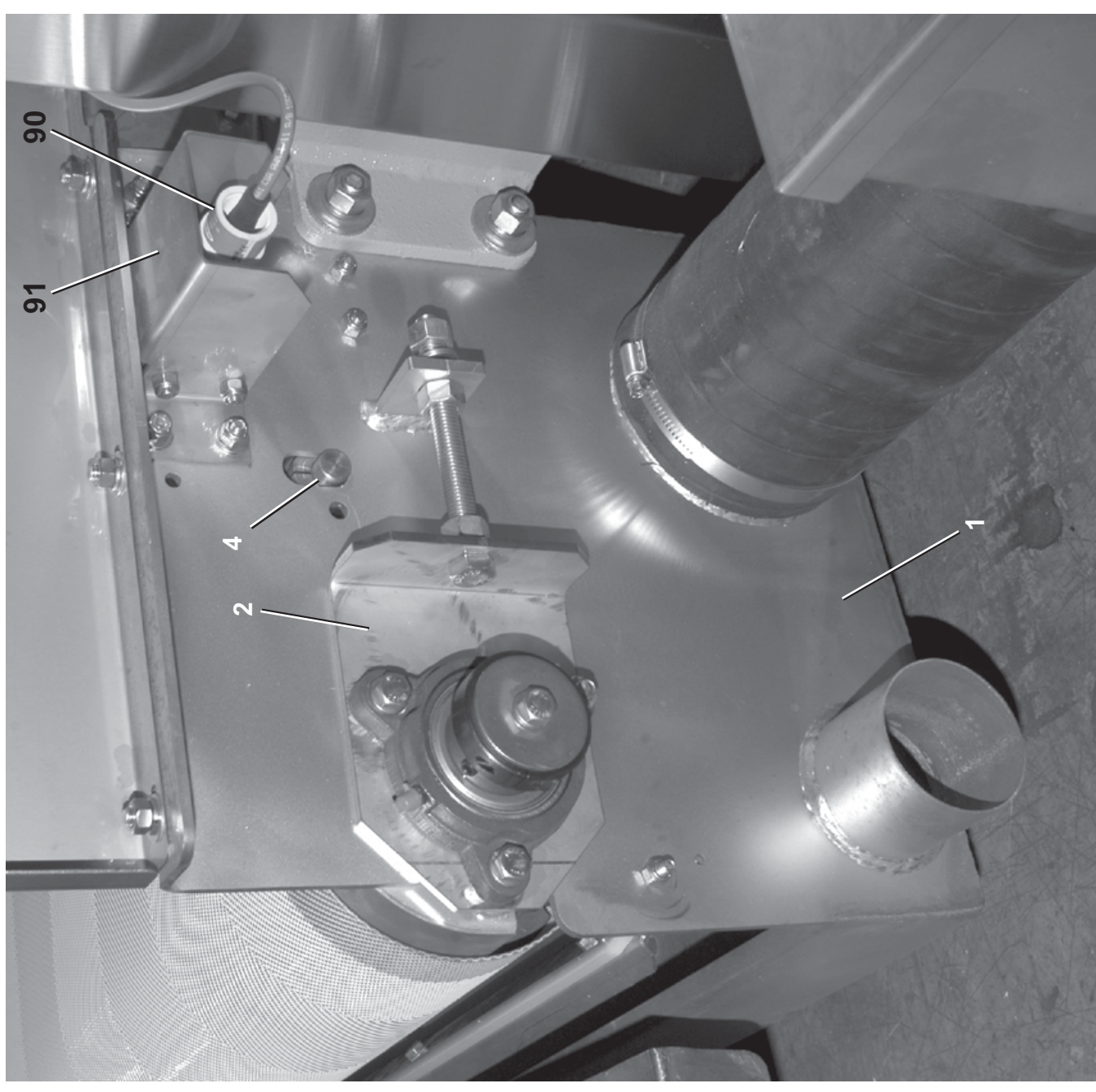

**Conveyor Unload End - 0" Bed Extension
 (00A, 00B)**

Conveyor Unload End Assemblies
MP1540, MP1556, MP1640, MP1656, MP1A50, MPL556, MPL640, MPL656

BMP110010/2020275B
 (3 / 8)



Pellerin Milnor Corporation
 P. O. Box 400, Kenner, LA 70063-0400

Litho in U.S.A.

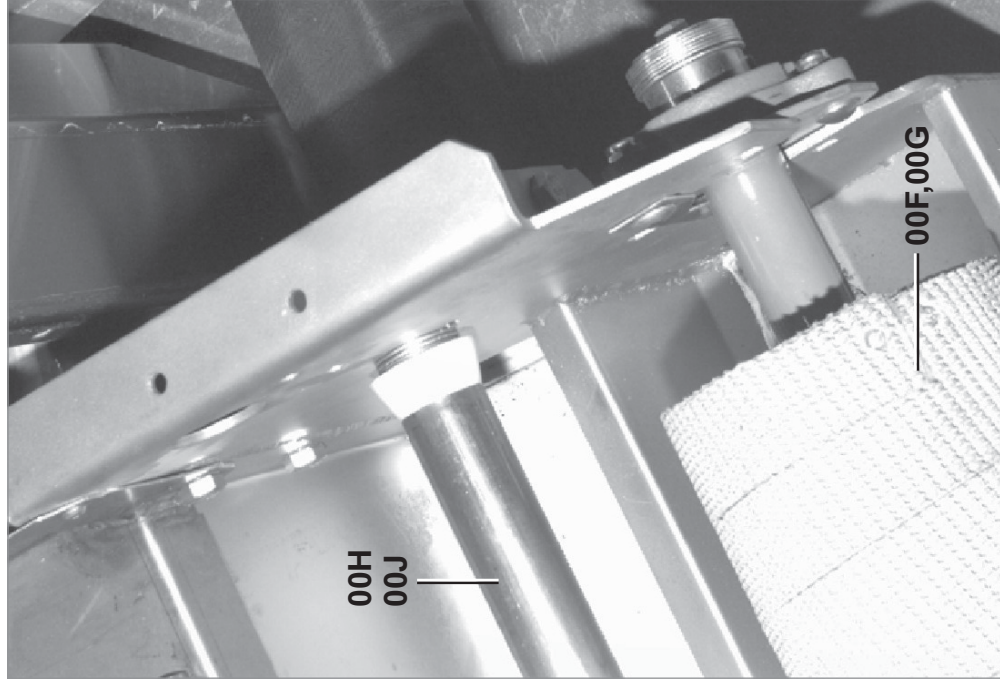

**Top view: Drive Roller and
 Tension "Snubber" Roller**

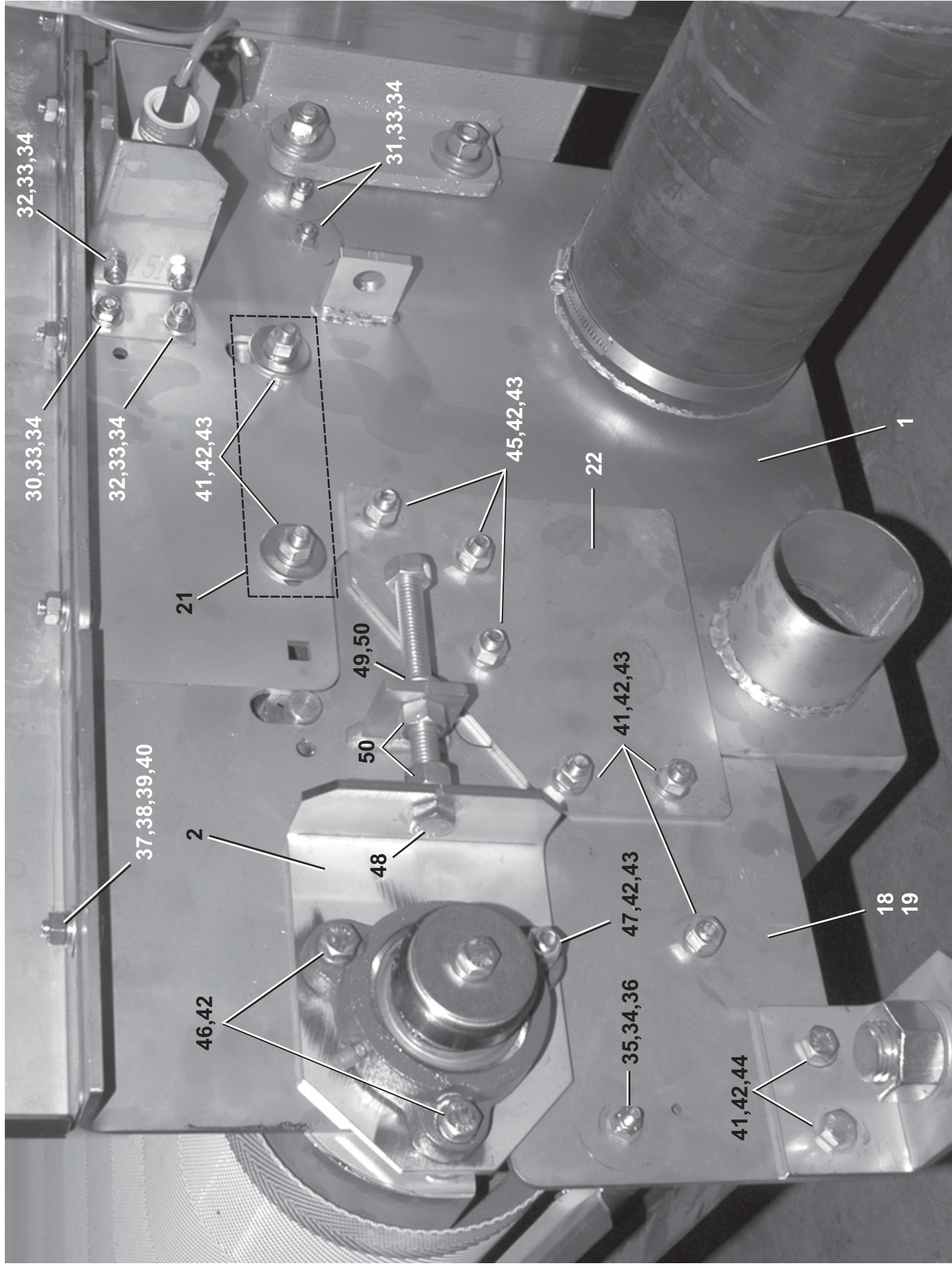

**Conveyor Unload End: Typical hardware connections
 (00C shown)**

Conveyor Unload End Assemblies
MP1540, MP1556, MP1640, MP1656, MP1A50, MP1556, MPL640, MPL656

BMP110010/2020275B
 (4 / 8)



Pellerin Milnor Corporation
 P. O. Box 400, Kenner, LA 70063-0400

Litho in U.S.A.

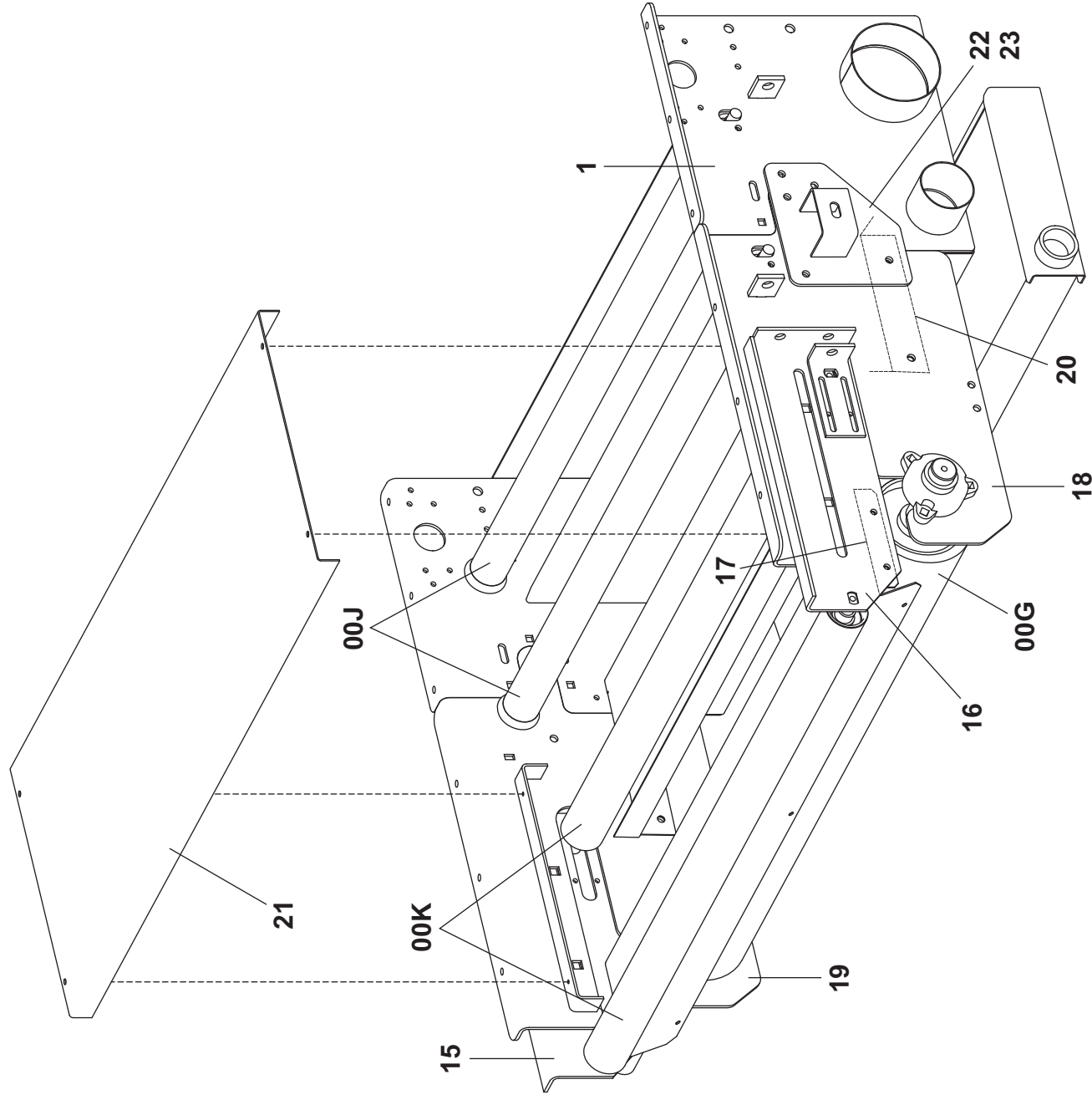

**Conveyor Unload End : 12"-24" Bed Extension
 (00D)**

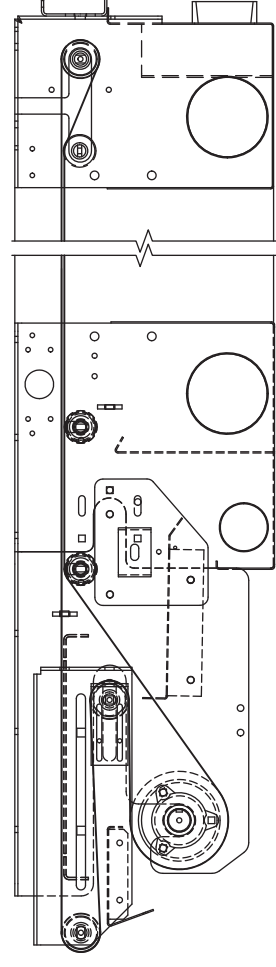

**Belt Path for 12"-24" Bed Extension
 (00D)**

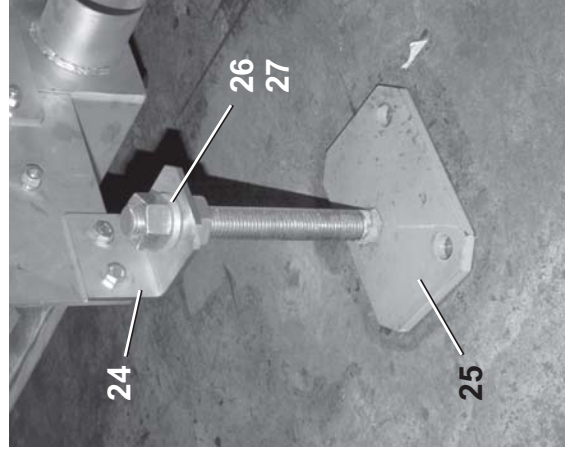

**Support Leg for Bed Extensions
 (00C, 00D, 00E)**

Conveyor Unload End Assemblies
MP1540, MP1556, MP1640, MP1656, MP1A50, MPL556, MPL640, MPL656

BMP110010/2020275B
 (5 / 8)



Pellerin Milnor Corporation
 P. O. Box 400, Kenner, LA 70063-0400

Litho in U.S.A.

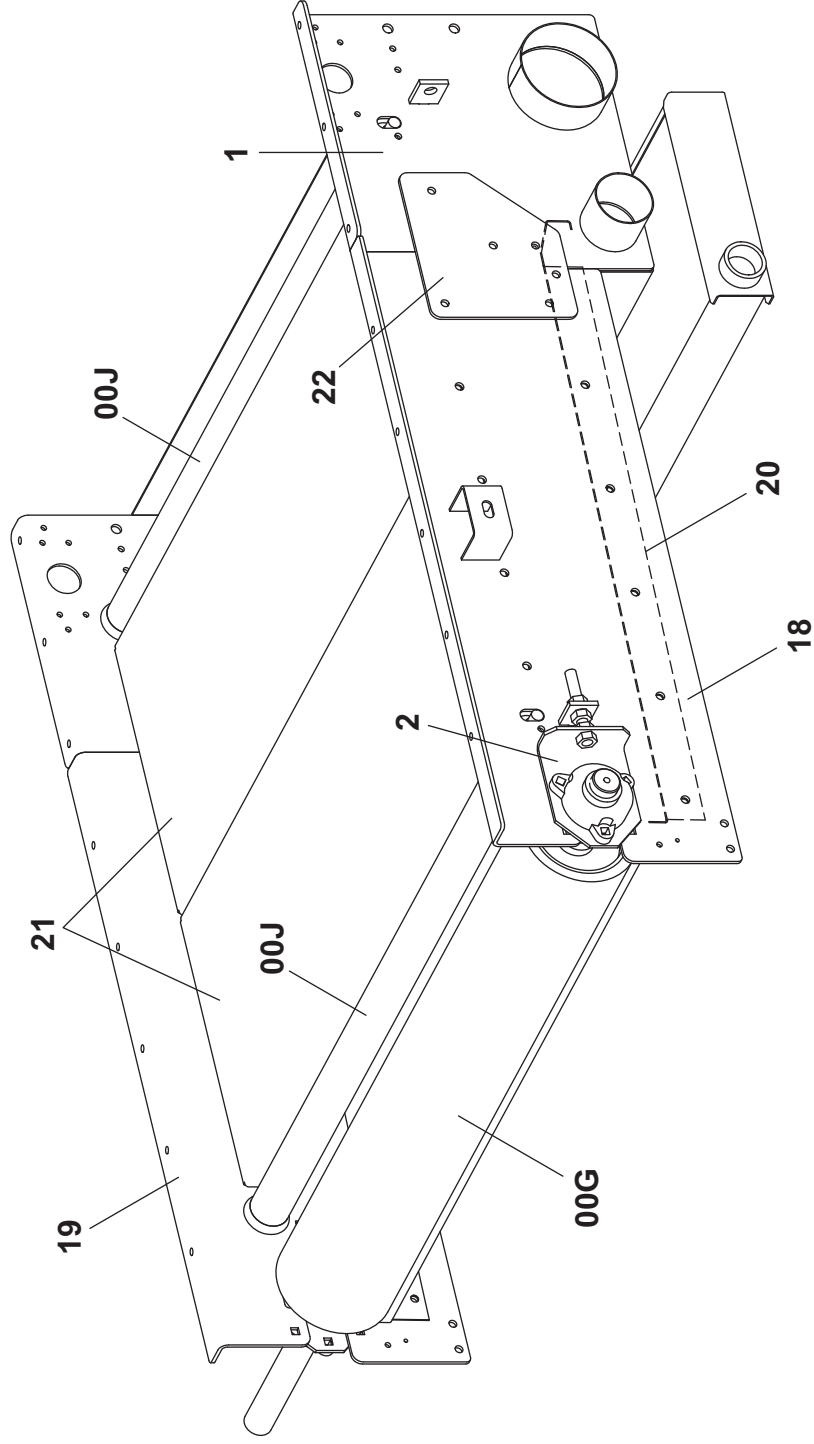

**Conveyor Unload End : 35" Bed Extension
 (00E)**

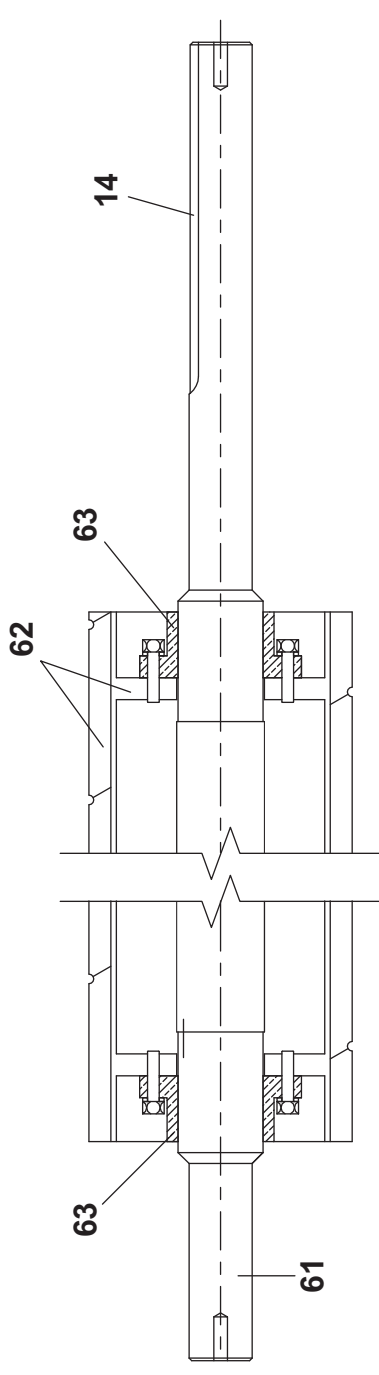

Detail A: Drive Roller (00F, 00G)

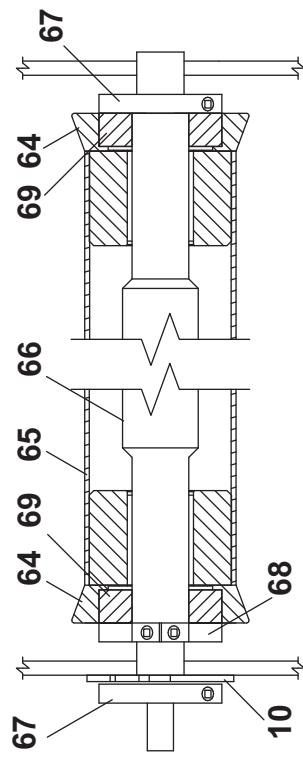

Detail B: Tension Roller "Snubber" (00H,00J)

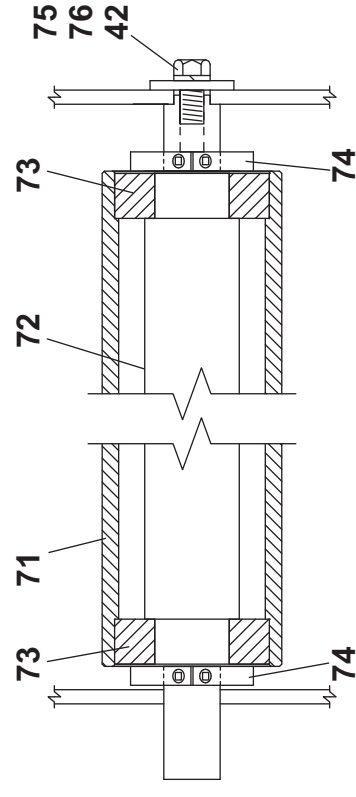

Detail C: Tension Roller (00K)

Conveyor Unload End Assemblies

MP1540, MP1556, MP1640, MP1656, MP1A50, MPL556, MPL640, MPL656

BMP110010/2020275B
(6 / 8)



Pellerin Milnor Corporation
P. O. Box 400, Kenner, LA 70063-0400

Litho in U.S.A.

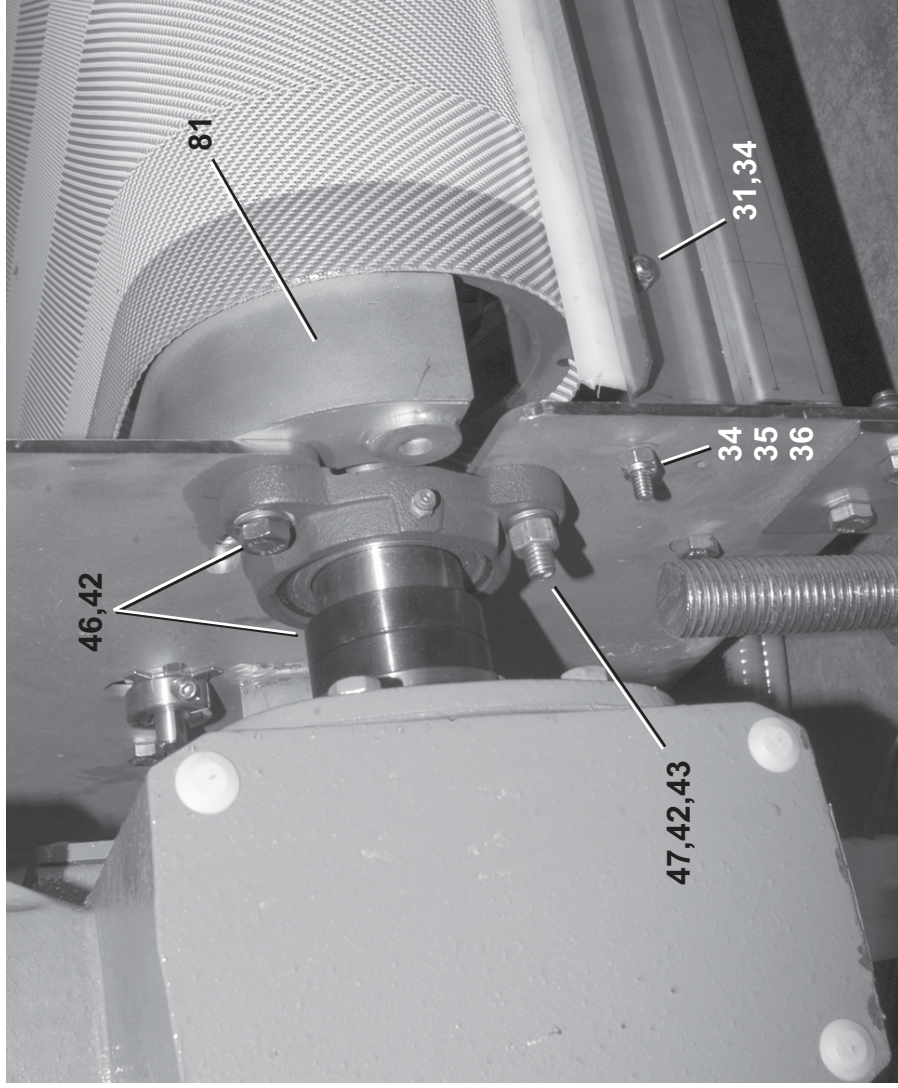

Installing Fenders

To install fenders to the discharge roller, remove the idler end roller to release tension on the belt. Move the belt to find the bolts of the flange bearings. Remove these bolts. Put in the fenders. Install the bolts through the fender, the bearing mounting holes, and the flange bearings.

Install the Roll Wiper Assembly.

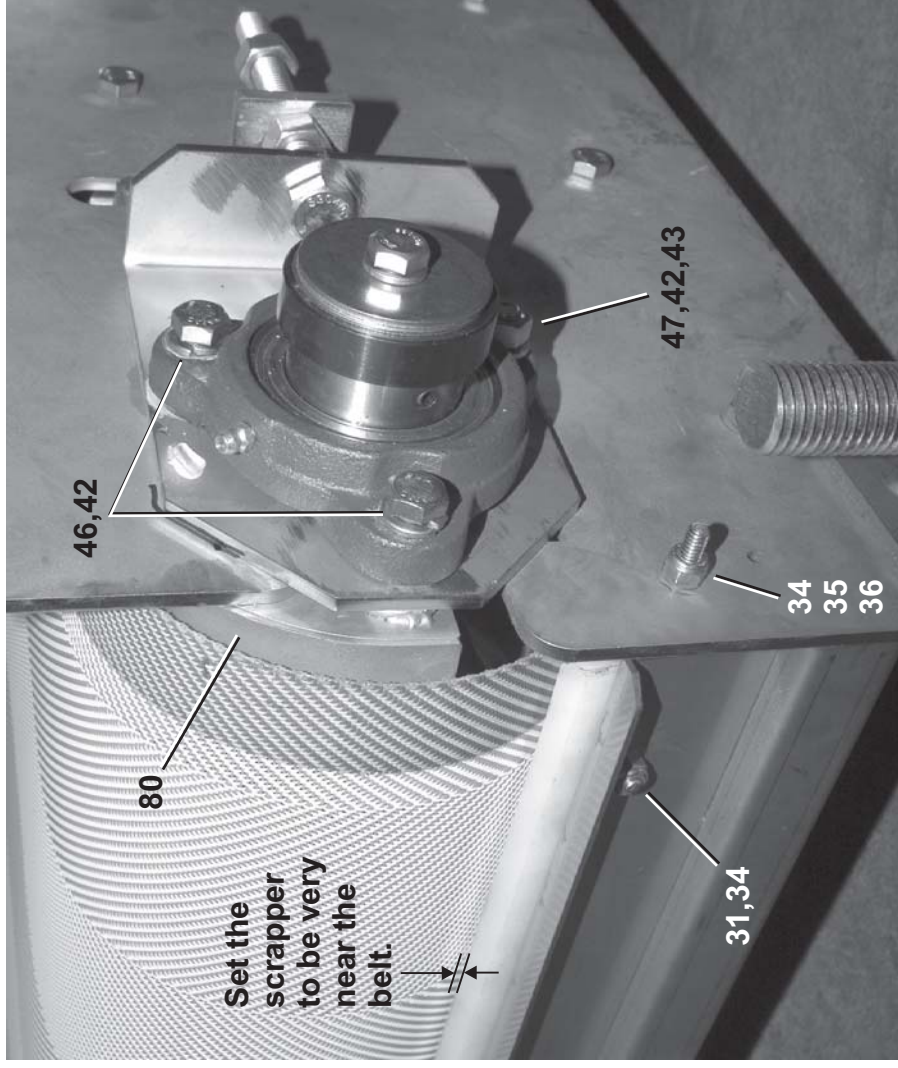

Roll Wiper Assembly

Parts are available to add the Roll Wiper Assembly to the conveyor. See the parts list.

The picture shows the installed roll wiper assembly. The bolt and the nut (items 34,35) are a pivot point for the Roll Wiper Assembly adjustment. Set the scraper to be very near the belt. Tighten the bolt to lock the position of the scraper.

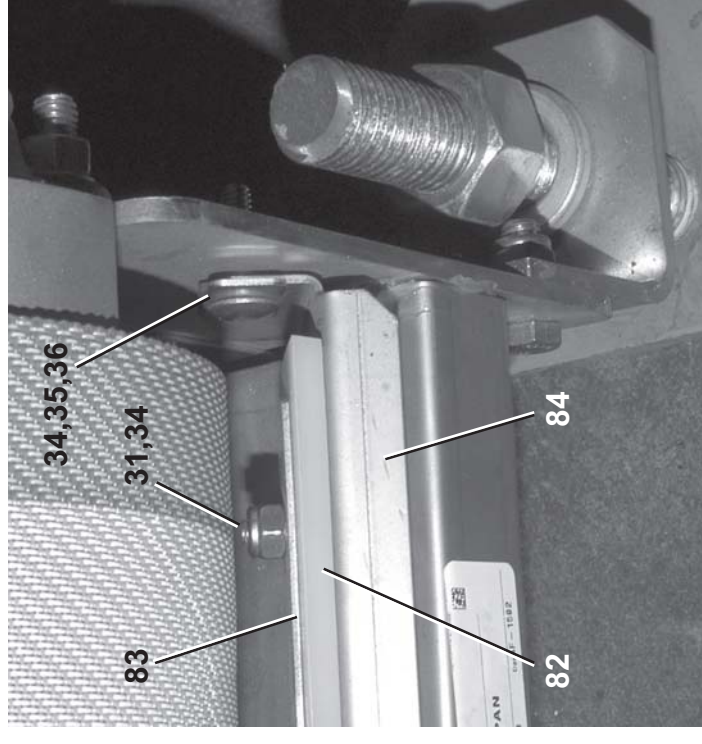

Conveyor Unload End Assemblies

MP1540, MP1556, MP1640, MP1656, MP1A50, MP1A56, MP1A50, MP1A56, MP1640, MP1656, MPL556, MPL640, MPL656



Pellerin Milnor Corporation
P. O. Box 400, Kenner, LA 70063-0400

Litho in U.S.A.

BMP110010/2020275B
(7 / 8)

Used In	Item	Part Number	Description	Comments
<p>Parts List—Conveyor Unload End Assemblies Find the correct assembly first, then find the needed components. The item letters (A, B, C, etc.) assigned to assemblies are referred to in the "Used In" column to identify which components belong to an assembly. The item numbers (1, 2, 3, etc.) assigned to components relate the parts list to the illustration.</p>				
	A	ALC420174	UNLOADEND DRIVE 51W ASSEMBLY	MP1Axx, 0" EXTENSION AVAILABLE ONLY
	B	ALC420177	UNLOAD END DRIVE ASSEMBLY	MP15xx, MP16xx MLP15xx, MLP16xx 0" EXTENSION
	C	ALC420180	UNLOAD END DRIVE ASSM 8" EXT	MP15xx, Mp16xx MPL5xx, MPL16xx 8" EXTENSION
	D	ALC420182	UNLOAD END DRIVE ASSM 24" EXT	MP15xx, Mp16xx MPL15xx, MPL16xx 12-24" EXTENSION
	E	ALC420184	UNLOAD END DRIVE ASSM 35" EXT	MP15xx, MPL15xx MP16xx, MPL16xx 35" EXTENSION
	F	APC50005	51W DRIVE LAGGED 1.437 INPUT	MP1Axx
	G	APC42005	42W DRIVE LAGGED 1.44-SSPRESS	MP15xx, Mp16xx MPL5xx, MPL6xx
	H	ALC50120	DRIVE SNUBBER ROLLER 51W	MP1Axx
	J	ALC50059	DRIVE SNUBBER ROLLER-SSPRESS	MP15xx, Mp16xx MPL5xx, MPL6xx
	K	ALC50060A	TENSION ROLLER 42W SS-BRNG	MP15xx, Mp16xx MPL5xx, MP16xx
	L	ALC420130	UNLOADEND ROLLER WIPER ASSY	MP15xx, Mp16xx MPL5xx, MPL6xx
	M	ALC420130A	UNLOADEND ROLL WIPER 51W ASSY	MP1Axx
<p>-----COMPONENTS-----</p>				
A	1	W4 23626	MP1A03 UNLOAD END WLMT-SSPRESS	
BCDE	1	W4 23602	UNLOAD END WLMT-SSPRESS	
ABCE	2	04 23204	DRIVE ROLLER ADJ BRKT	
all	6	04 22999	TORQARM MTG ANGLE	
B	7	04 23534	TORQARM-SSPRESS CONV	
ACDE	7	04 23578	TORQARM +8-SSPRESS CONV	
ABCD	8	04 22997	TORQUEARM MTG BRKT-SSPRESS	
all	9	ALC420063	TORQUE ARM BUSHING ASSEMBLY	
ABCDE	10	06 20070	LOCKING WASHER ROLLER SHAFT	

Used In		Item	Part Number	Description	Comments
D		17	04 20366	ROLLER BLOW PIPE MTG BRKT	
C		18	W4 23587	BRNG SUPP 8" EXT-LEFT WLDMT	
D		18	W4 23583	BRNG SUPP 24" EXT-LEFT WLDMT	
E		18	W4 23554	BRNG SUPP 35" EXT-LEFT WLDMT	
C		19	W4 23587A	BRNG SUPP 8" EXT-RT WLDMT	
D		19	W4 23583A	BRNG SUPP 24" EXT-RT WLDMT	
E		19	W4 23554A	BRNG SUPP 35" EXT-RT WLDMT	
C		20	04 23588	8" ENTEND DRIP PAN	
D		20	04 23584	24" ENTEND DRIP PAN	
E		20	04 23556	35" ENTEND DRIP PAN	
C		21	04 23585	UNLOADEND BELT SUPP-8"EXT	
D		21	04 20365	CAKE SUPPORT BED	
E		21	04 23555	BELT SUPPORT 35" EXTENSION	
C		22	04 23589	8" PRESS EXT. DOUBLER PLATE	
D		22	W4 23586	24" EXT DBL PLATE WLDMT-LEFT	
E		22	04 23557	PRESS EXTENSION DOUBLER PLATE	
D		23	W4 23586A	24" EXT DBL PLATE WLDMT-RT	
ACDE		24	04 20356	UNLOADEND LEG-SSPRESS CONV+35L	
ACDE		25	W4 20358	FOOTPAD WLMT-UNLOADEND SSPRESS	
ACDE		26	15U400	LOCKWASHER MEDIUM 1" ZINCPL	
ACDE		27	15G250	HXNUT 1-8UNC2B SAE ZNC GR2	
all		30	15K033	BUTSOKCAPSCR 1/4-20X5/8 SS18-8	
all		31	15N186	HXCAPSCR 1/4-20X3/4 SS18-8	
all		32	15K041S	HEXCAPSCR 1/4-20UNC2AX1 SS18-8	
all		33	15U188	FLTWASH 1/4 STD COMM SS18-8	
all		34	15G164NE	HEXLOKNUT NYL 1/4-20 UNC2A SS.	
all		35	15A008	CARBOLT 1/4"-20UNC2X1" SS18-8	
all		36	04 20616	CONLO.BELT WASHER	
all		37	15K052	HXCAPSCR 5/16-18UNC2AX3/4 SS18	
all		38	15U200S	FLATWASHER US STD 5/16 SS18-8	
all		39	15U205	LOCKWASHER MEDIUM 5/16" 18-8SS	
all		40	15G186	HEXNUT 5/16-18UNC2 SS18-8	
all		41	15K096	HEXCAPSCR 3/8-16UNC2X1SS18-8	
all		42	15U260	LOCKWASHER MEDIUM 3/8 SS18-8	
all		43	15G206B	HEXNUT 3/8-16UNC2 BRASS	
all		44	15G201	HXLOKNUT 3/8-16 NYL/SS TYPE NE	

Conveyor Unload End Assemblies

MP1540, MP1556, MP1640, MP1656, MP1A50, MP1556, MPL640, MPL656

BMP110010/2020275B
(8 / 8)



Pellerin Milnor Corporation
P. O. Box 400, Kenner, LA 70063-0400

Litho in U.S.A.

Parts List—Conveyor Unload End Assemblies				Parts List, cont.—Conveyor Unload End Assemblies			
Used In	Item	Part Number	Description	Used In	Item	Part Number	Description
Find the correct assembly first, then find the needed components. The item letters (A, B, C, etc.) assigned to assemblies are referred to in the "Used In" column to identify which components belong to an assembly. The item numbers (1, 2, 3, etc.) assigned to components relate the parts list to the illustration.							
all	45	15A010	CARRSCR 3/8-16UNC2X1 SPECIAL	K	74	54JH10750S	SHFTCOL 3/4X1+1/2X.5 SS C-T
all	46	15K112	HXCAPSCR 3/8-16X1+1/2 SS18-8	K	75	15K083S	HXCAPSCR 3/8-16NCX1/2 SS18-8
all	47	15A021S	CARBOLT 3/8-16X1.5 SS18-8	K	76	15U245	FLTWASH 3/8 STD COMM 18-8 SS
all	48	15K203S	HEXTAPSCR 1/2-13UNC2AX5 SS18-8	all	77	W2 21162A	SUPPLY 5COMP WLMT=4232 LF MNT
all	49	15U300	LOKWASHER REGULAR 1/2 ZINC PLT	all	78	W2 21162	*SUPPLY 5COMP WLMT=4232F
all	50	15G234B	HEXNUT 1/2-13UNC2B BRASS	all	80	W4 21162	ROLLER SIDE GUARD WLMT-RT
all	51	15K144C	HEXCAPSCR 7/16-14UNC X 2.5 GR	all	81	W4 21162A	ROLLER SIDE GUARD WLMT-LF
all	52	15G222	HXFJNUT 7/16-14UNC2B ZINC	L	82	04 21118	UHMW ROLLER WIPER 42W
all	53	15G222C	HEXNUT 7/16-14UNC2B ZINC GR2	M	82	04 21167	ROLLER WIPER BRKT-51W
all	54	15U271	LOKWASH INTOOTH 7/16ZN	L	83	04 21119	ROLLER WIPER STRAP-42W
all	55	15U312	HARD FWASH 3/4ODX33/64IDX.115	M	83	04 21168	UHMW ROLLER WIPER 51W
all	56	15U202	FLATWSHR.50ID1.75OD11GA ZNC	L	84	04 21120	ROLLER WIPER BRKT-42W
all	57	60B065	RUBBER MNT CTR BONDED 40 DURO	M	84	04 21169	ROLLER WIPER STRAP-51W
all	58	04 20796	SLEEVE=TORQUE ARM BUSHING	all	86	15U310	LOKWASHER REGULAR 1/2 SS18-8
all	59	02 18571A	PISTON ROD WASHER-.25"TK	all	87	15K086	HXCAPSCR 3/8-16NCX3/4 SS18-8
all	60	15U490	FLTWASH 1+1/2X17/32X1/4 ZINC	all	88	03 BC2X3P	BRKT=1STG PRESS PHOTOEYE+CVR
G	61	X4 23224	CONV ROLLER SHAFT-1.44DRIVE	all	89	09RPE010E	P.E. EMITTER AC #SM303E W/30'
F	61	X4 21090	DRIVE ROLLER SHAFT-51W BED	all	90	03 BZ0204	BRKT=PHOTOEYE SSPRESS CONV
G	62	54C006	VGORPXTLAGDRMPULLY#D5S40XT20	all	91	09RPE010R	PHOTOEYE RECEIVER AC
F	62	54C006A	VGORPXTLAGDRMPULLY#T5S48XT20				
GF	63	54C006XTB	VGORP XT BUSH 1 15/16 B#XTB20X				
JH	64	X4 23126	TRACKING ROLLER BUSHING S/S				
J	65	X4 23126A	TUBING 2" OD X 42.00 LG 304 SS				
H	65	X4 21093	TUBING 2"OD X 51.00LG 304SS				
J	66	X4 23109	IDLER SHAFT .75DX45.50LG				
H	66	X4 21091	IDLER SHAFT.75DX54.50LG				
JH	67	54JH10625S	SHFTCOL 5/8X1+5/16X.437 SS C-T				
JH	68	54J10625S2	SHFCOL 5/8X1+5/16X.437 2PC SS				
JH	69	54AB75001	BALBRG.75X1.625X.437#SSR122RS				
K	71	X4 23433	TENSION ROLLER 2.50D-ER14 BRNG				
K	72	X4 23434	TENSION ROLLER SHAFT-SS BRNG				
K	73	54AB25001	BALBRG 25X52X15MM-#SS62052RS				

Load End Rollers & Belt Tracking
MP1540, MP1556, MP1640, MP1656, MP1A50, MP1556, MPL640, MPL656

BMP110011/2020275B
 (1/4)

MILNOR
 Pellerin Milnor Corporation
 P. O. Box 400, Kenner, LA 70063-0400

Litho in U.S.A.

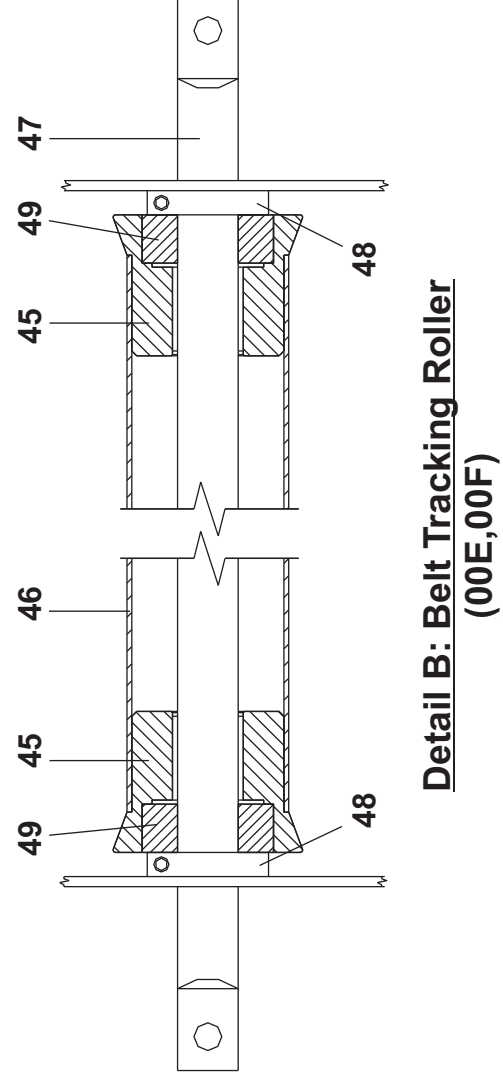
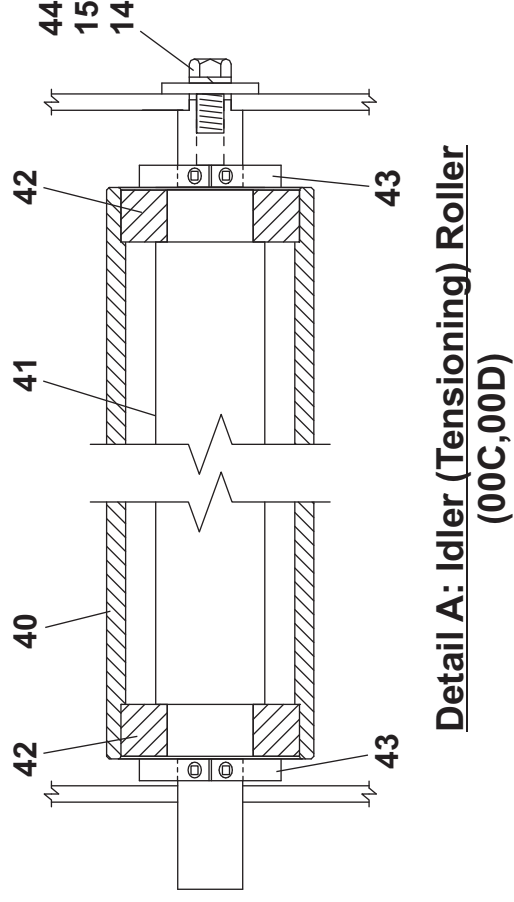
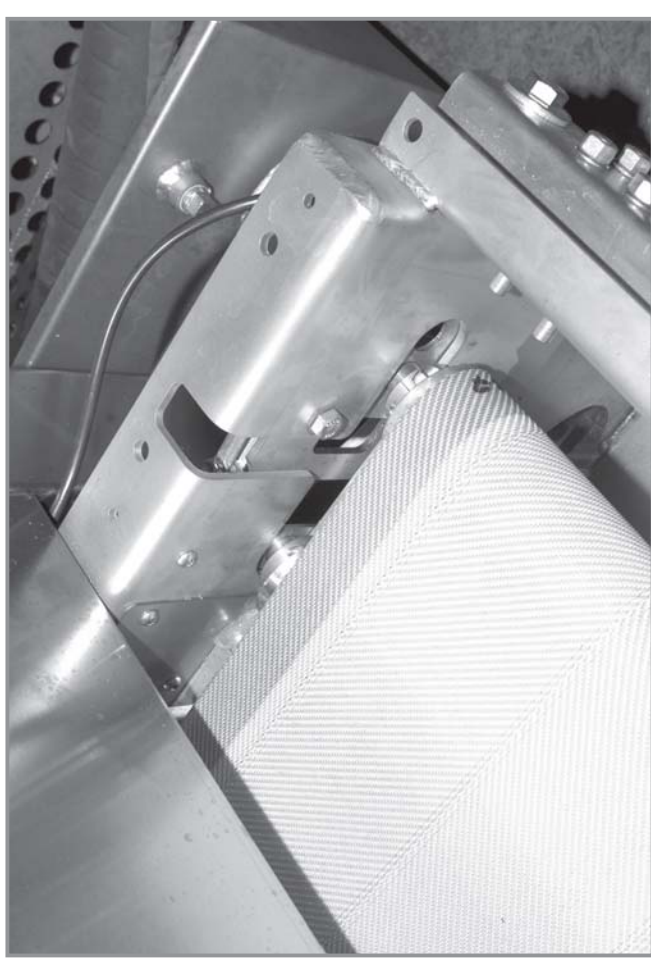
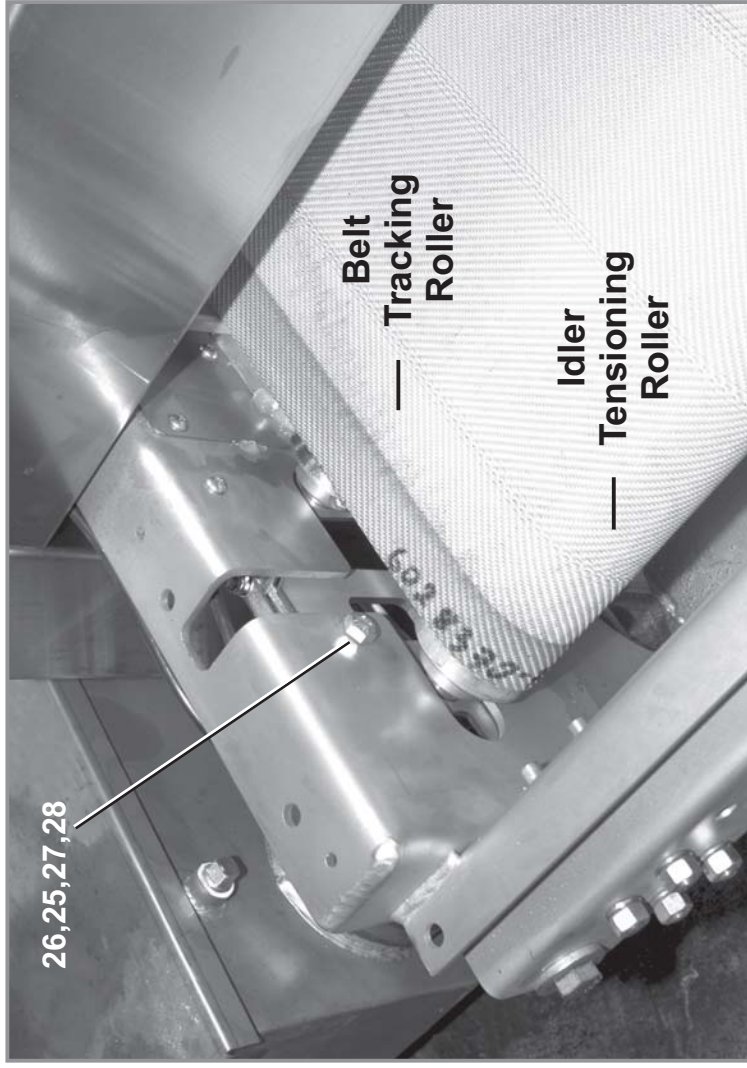

Load End Rollers & Belt Tracking
MP1540, MP1556, MP1640, MP1656, MP1A50, MP1556, MPL640, MPL656

BMP110011/2020275B
 (2 / 4)



Pellerin Milnor Corporation
 P. O. Box 400, Kenner, LA 70063-0400

Litho in U.S.A.

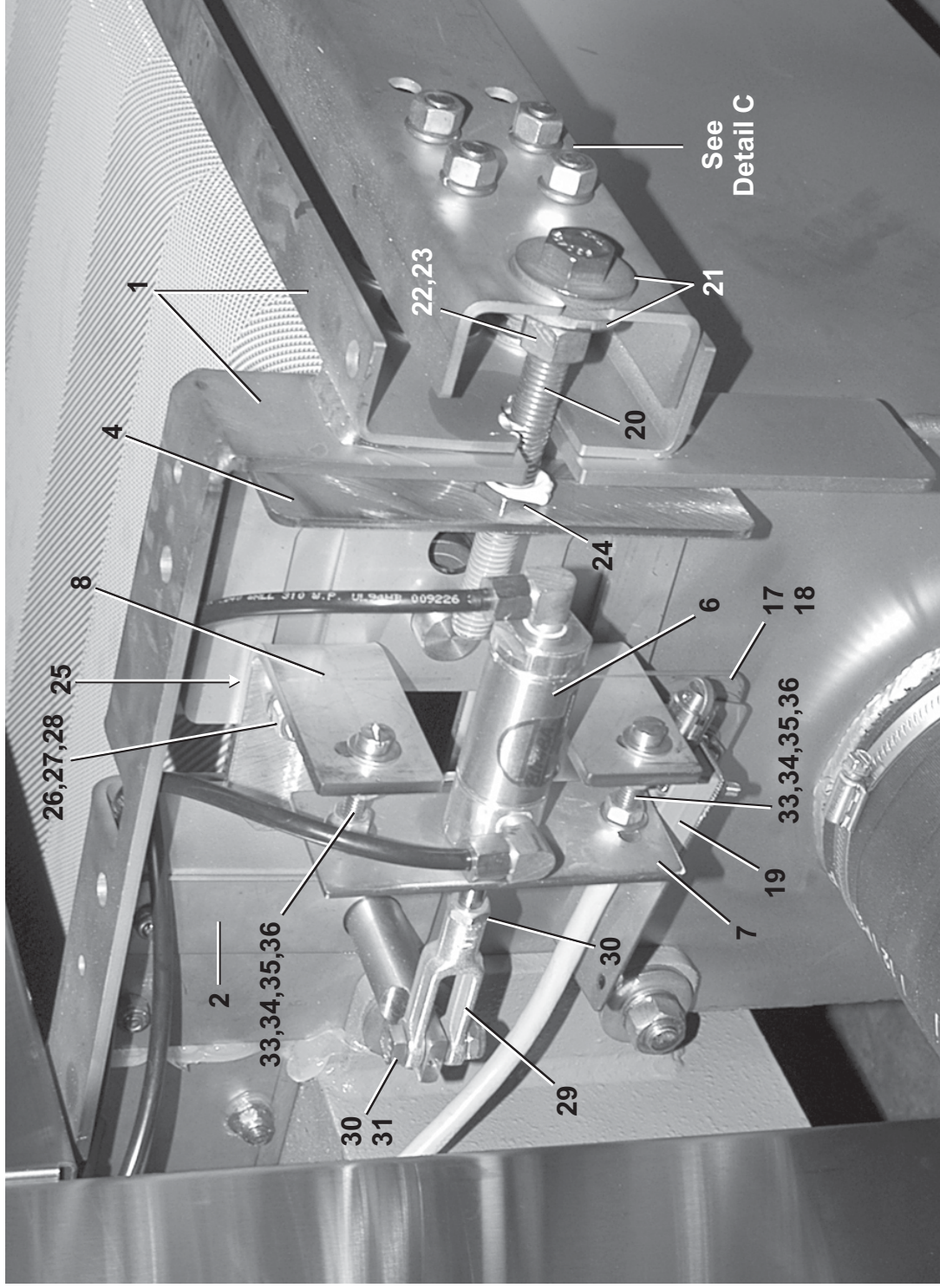

Load End Rollers & Belt Tracking

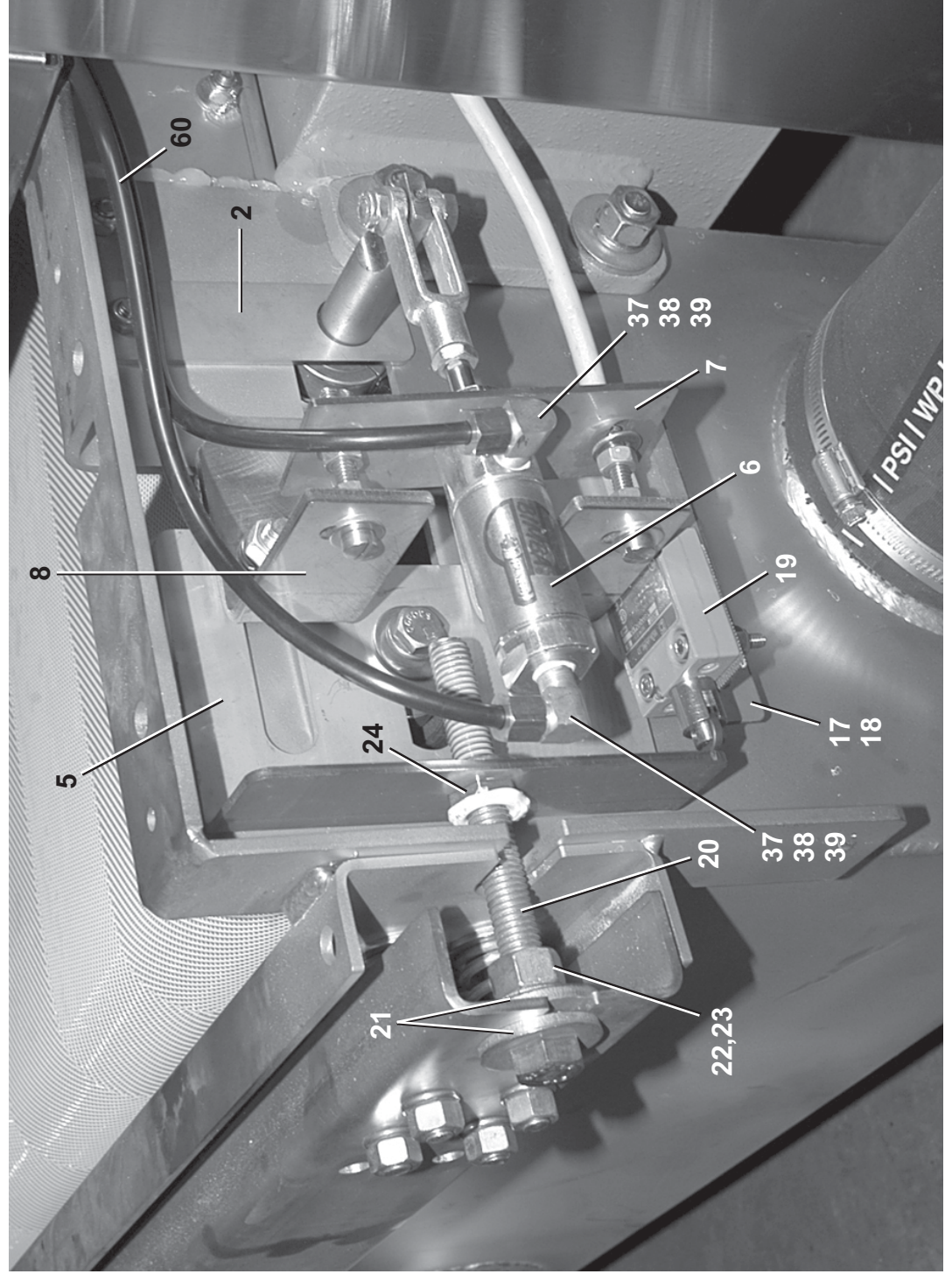

Load End Rollers & Belt Tracking

MP1540, MP1556, MP1640, MP1656, MP1A50, MP1A55, MP1A56, MP1A58, MP1A59, MP1A60, MP1A61, MP1A62, MP1A63, MP1A64, MP1A65, MP1A66, MP1A67, MP1A68, MP1A69, MP1A70, MP1A71, MP1A72, MP1A73, MP1A74, MP1A75, MP1A76, MP1A77, MP1A78, MP1A79, MP1A80, MP1A81, MP1A82, MP1A83, MP1A84, MP1A85, MP1A86, MP1A87, MP1A88, MP1A89, MP1A90, MP1A91, MP1A92, MP1A93, MP1A94, MP1A95, MP1A96, MP1A97, MP1A98, MP1A99, MP1A100



Pellerin Milnor Corporation
P. O. Box 400, Kenner, LA 70063-0400

BMP110011/2020275B
(3 / 4)

Litho in U.S.A.

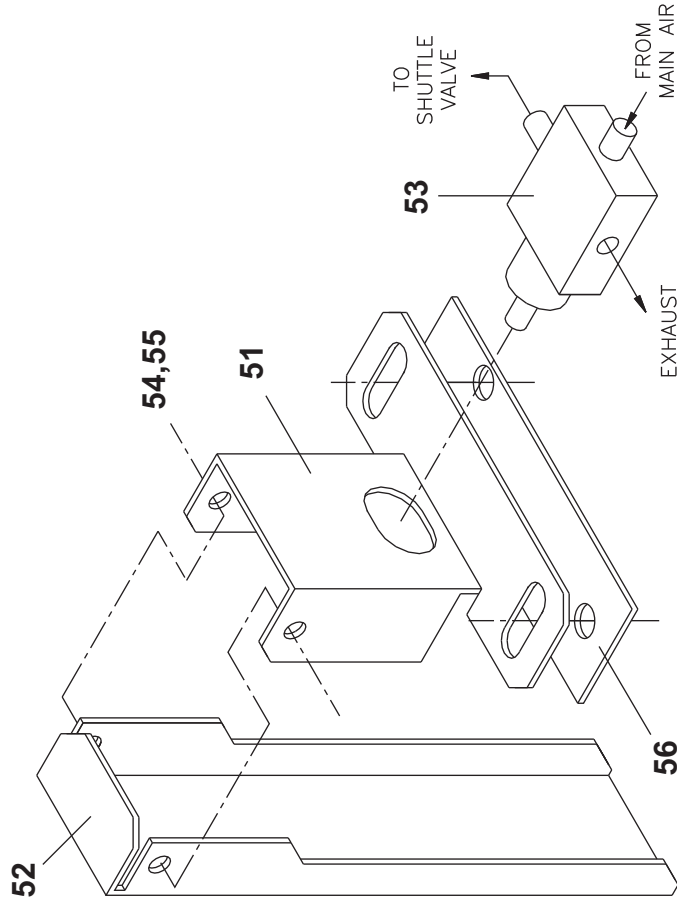
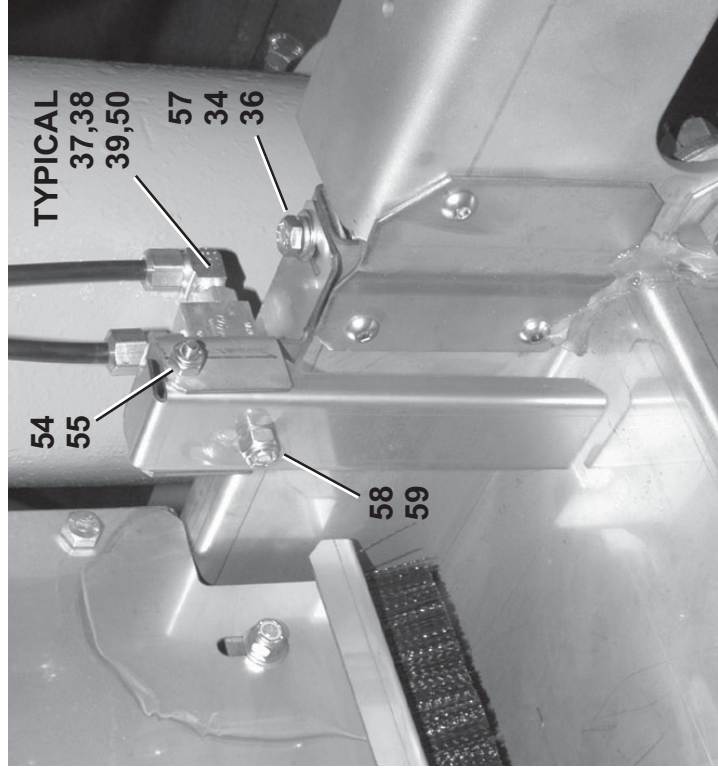

DETAIL D: BELT TRACKING SWITCH

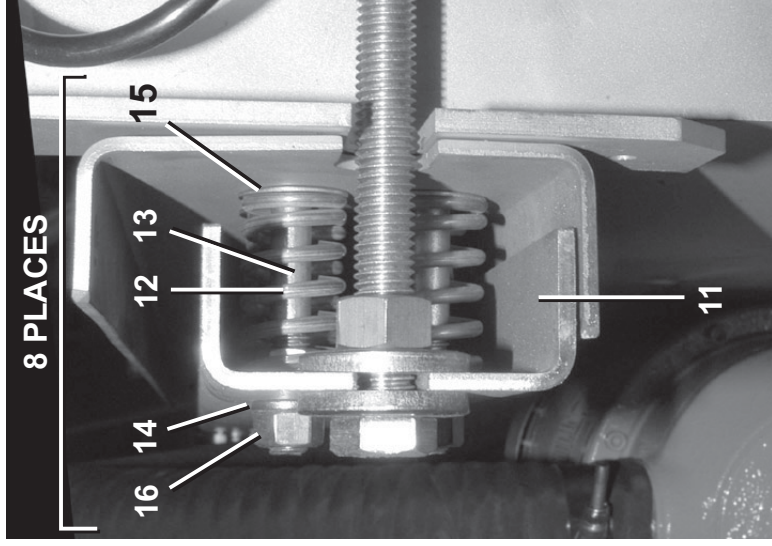

DETAIL C: TENSION BAR



Detail D: Photo Eye

Find the correct assembly first, then find the needed components. The item letters (A, B, C, etc.) assigned to assemblies are referred to in the "Used In" column to identify which components belong to an assembly. The item numbers (1, 2, 3, etc.) assigned to components relate the parts list to the illustration.

Used In	Item	Part Number	Description	Comments
			-----ASSEMBLIES-----	
	A	ALC420178	LOAD END IDLER ASSEMBLY	MP15xx, MP16xx MPL5xx, MPL6xx
	B	ALC420185	LOAD END IDLER 51W ASSEMBLY	MP1Axx
	C	ALC50060A	TENSION ROLLER 42W SS-BRNG	MP15xx, MP16xx MPL5xx, MPL5xx
	D	ALC50122	TENSION ROLLER 51W-SS BRNG	MP1Axx
	E	ALC50065	BELT TRACKING ROLLER-SSPRESS	MP15xx, MP16xx MPL5xx, MPL6xx
	F	ALC50121	BELT TRACKING ROLLER-51W	MP1Axx
	G	ALC420100	BELT TRACKING SWITCH ASSY	
			-----COMPONENTS-----	
A	1	W4 23615	LOAD END WLMT-SSPRESS	
B	1	W4 23624	MP1A03 LOAD END WLMT-SSPRESS	
all	2	04 23205B	TRACK ROLLER SUPPORT PLATE	
A	3	04 23203	LOAD END CROSS BRACE	
B	3	04 21088	LOAD END CROSS BRACE-51W BED	
all	4	04 20568	TENSION ROLLER ADJ BRKT-LF	
all	5	04 20568A	TENSION ROLLER ADJ BRKT-RT	
all	6	27C211	AIRCYL1+1/16BOREX1/2"STK DBL	
all	7	04 23214	BELT TRACKING CYL MTG BRKT	
all	8	04 23215	BELT TRACKING BRKT	
all	9	04 23232	BELT TRACKING COVER-RT	
all	10	04 23232A	BELT TRACKING COVER-LEFT	
A	11	04 20570	BELT TENSIONING BAR	
B	11	04 21089	BELT TENSION BAR-51W BED	
all	12	02 18187	SPRING=OUTER DOOR 60 WEHU	
all	13	04 20571	STUD 3/8-16UN X 3.25LG	
all	14	15U260	LOCKWASHER MEDIUM 3/8 SS18-8	
all	15	15U245	FLTWASH 3/8 STD COMM 18-8 SS	
all	16	15G206B	HEXNUT 3/8-16UNC2 BRASS	
all	17	04 20596	BELT STOP SW.MTG BRKT-SSPRESS	
all	18	04 20597	BELT STOP SW MTG PLATE	

Load End Rollers & Belt Tracking

MP1540, MP1556, MP1640, MP1656, MP1A50, MPL556, MPL640, MPL656

BMP110011/2020275B
(4 / 4)



Pellerin Milnor Corporation
P. O. Box 400, Kenner, LA 70063-0400

Litho in U.S.A.

Parts List—Load End Rollers & Belt Tracking				Parts List, cont.—Load End Rollers & Belt Tracking			
Used In	Item	Part Number	Description	Used In	Item	Part Number	Description
Find the correct assembly first, then find the needed components. The item letters (A, B, C, etc.) assigned to assemblies are referred to in the "Used In" column to identify which components belong to an assembly. The item numbers (1, 2, 3, etc.) assigned to components relate the parts list to the illustration.							
all	21	15U310S	FLATWASH-SS .53 X 1.37 .187T	all	51	04 23217	BELT TRACKING SWITCH BRKT
all	22	15U310	LOKWASHER REGULAR 1/2 SS18-8	all	52	04 23219	BELT TRACKING ACTUATOR
all	23	15G234B	HEXNUT 1/2-13UNC2B BRASS	all	53	96N005	3WAY AIROP CONT.VLV.CLIPP#MJV3
all	24	15G225H	HEXFLGNUT 1/2-13 SERRATED 18-8	all	54	15N154A	PHILPSHDMACHSCR 10-24 X2" 18-8
all	25	15G214SS	HXJAMNUT 3/8-16UNC 18-8 SS	all	55	15G126	HXLOCKNUT NYLON 10-24 UNC SS N
all	26	15K100	HEXCAPSCR 3/8-16X1+1/4 SS18-8	all	56	X4 23218	BELT TRACKING TAP STRIP
all	29	17A007	ADJ YOKE END-CAD 5/16-24NF #27	all	57	15K033	BUTSOKCAPSCR 1/4-20X5/8 SS18-8
all	30	15G191	HXFINJAMNUT 5/16-24UNC2 ZINC G	all	58	15N174	HXCAPSCR 1/4-20UNC2X5/8SS18-8
all	31	15K062	HEXCAPSCR 5/16-18X1 18-8SS	all	59	15U342	FLTWASH .255/.260IDX.750DX.125
all	32	15G193	HEXLOKNUT 5/16-18UNC2A NYL STL	all	60	60E004TE	1/4"OD X.170"ID NYL(BLK)TUBING
all	33	15N200	FILMACSCR 1/4-20UNCX2 SS18-8 S	all	61	09RPE010E	P.E. EMITTER AC #SM303E W/30'
all	34	15U188	FLTWASH 1/4 STD COMM SS18-8	all	62	09RPE010R	PHOTOEYE RECEIVER AC
all	35	15U181	LOKWASHER MEDIUM 1/4 SS18-8				
all	36	15G164NE	HEXLOKNUT NYL 1/4-20 UNC2A SS.				
all	37	53A031B	BODY-EL90MALE.25X1/8 #269C-42B				
all	38	53A500	SLEEVE DELRIN 1/4"OD#60PT-4				
all	39	53A501	TUBE INSERT .163"OD #63PT-4-40				
A	40	X4 23433	TENSION ROLLER 2.50D-ER14 BRNG				
B	40	X4 21094	TENSION ROLLER 2.38DX51.75LG				
A	41	X4 23434	TENSION ROLLER SHAFT-SS BRNG				
B	41	X4 21095	TENSION ROLL SHAFT 1"0DX55"LG				
all	42	54AB25001	BALBRG 25X52X15MM-#SS62052RS				
all	43	54JH10750S	SHFTCOL 3/4X1+1/2X.5 SS C-T				
all	44	15K083S	HXCAPSCR 3/8-16NCX1/2 SS18-8				
all	45	X4 23126	TRACKING ROLLER BUSHING S/S				
all	46	X4 23126A	TUBING 2" OD X 42.00 LG 304 SS				
all	46	X4 21093	TUBING 2"OD X 51.00LG 304SS				
A	47	X4 23109B	TRACKING SHAFT .75DX50.25LG				
B	47	X4 21092	TRACKING SHAFT .75DX59.25LG				
all	49	54AB75001	BALBRG.75X1.625X.437#SSR122RS				
all	50	53A059A	NUT 1/4"BR.HOLYOKE AND #61A-4				