

Published Manual Number/ECN: MAPM7E42BE/2019174A

- Publishing System: TPAS2
- Access date: 05/07/2019
- Document ECNs: NOT latest



# Service & Mechanical Parts

## Centrifugal Extractors

M7V4232C, L, R

M9V4232C, L, R

MMV4232C, MXV4232C



**Read the  
separate  
safety  
manual  
before  
installing,  
operating,  
or servicing**



# Table of Contents

## MAPM7E42BE/19174A

Page	Description	Document
1	Limited Standard Warranty	BMP720097/2019036
2	How to Get the Necessary Repair Components	BIUUUD19/20081231
3	Trademarks of Pellerin Milnor Corporation	BIUUUD14/20170713
4	Safety—Centrifugal Extractor	BIUUUS27PE/20051111
10	SAFETY ALERT for Owner/Managers and Maintenance Personnel: Using the Access Panel Interlock Bypass Key Switch	BICP1S01AB/20060111
11	How To Use the Red Safety Support(s) for Maintenance	BIUUUS06E2/20160823
13	Shipping Bracket Installation	BMP940019/2011152B
15	Safety Stand Installation	BMP940028/2011105B
17	About the Forces Transmitted by Milnor® Washer-extractors	BIWUUI02/20001108
19	Understanding Tag Guidelines	BIUUUI02PE/20160712
22	Safety Placard Use and Placement: M9V,MXS4232 & M9V4840	BMP030013/2013342B
24	Safety Placard Use and Placement ISO: MXS/M9V4232 & M9V4840	BMP030014/2013342B
<b>27</b>	<b>1. Service and Maintenance</b>	
28	Centrifugal Extractor Preventive Maintenance	BIPV7M01/20040324
38	Motor Maintenance	BIUUUM03/2011433A
42	Torque Requirements for Fasteners	BIUUUM04/20180109
50	Conveyor Lubrication & Chain Adjustments	BMP070001/2007042B
52	Conveyor Adjustment Procedures	BMP820015/1996322V
55	Installing Anti-Friction Strips	MSINC402AE/1986361N
56	Inclined Storage Conveyor Assembly Instructions	MSIND422AE/1986462N
<b>61</b>	<b>2. Shell and Door Assemblies</b>	
62	Shell Assembly M7E, M7V, M9E, M9v	BMP940020/2001204V
64	Load Chute Installation	BMP960009/2008105B
66	Load Chute Assembly M7E, M7V, M9E, M9V	BMP940021/2001204V
68	Extractor Auto Load Door	BMP990010/2013285A
70	Cosmetic Covers M7E, M7V, M9E, M9V,	BMP940017/2001204V
<b>73</b>	<b>3. Drive Assemblies</b>	
74	Drive Chart - M9V4232C,L,R MMV4232C,L,R MXV4232C,L,R	BMP000039/2009443B
75	Drive Base Assembly	BMP000041/2007166B
77	M7V4232x Belt Replacement	BIPV7M02/20080923
80	Belt Guard Installation	BMP940051/2001204V
82	Disc Brake Installation	BMP940018/2016302B
<b>85</b>	<b>4. Bearing Assemblies</b>	

## Table of Contents, continued

### MAPM7E42BE/19174A

<b>Page</b>	<b>Description</b>	<b>Document</b>
86	Bearing Assembly & Installation M7E,M7V,M9E,M9V	BMP940031/2002434V
88	Cylinders and Cotton Mod Piping	BMP050031/2018444B
92	Inflatable Rib Assembly	BMP110048/2018444A
<b>95</b>	<b>5. Frame, Pivots and Suspension</b>	
96	Installation of Pivot Ball Bushing	BMP930020/2001204V
98	Ball Bushing	BMP930026/2005105V
99	Hydro-cushion Cylinder Installation	BMP940023/2001204V
101	Hydrocushion Cylinders	BMP940024/2013224A
<b>103</b>	<b>6. Hydraulic Piping and Devices</b>	
104	Hydraulic Schematic	BMP050060/2013342B
105	Hydraulic Tank	BMP130011/2013355A
110	Hydraulic Hoses & Piping	BMP940054/2013212A
113	Hydraulic Tilt Cylinders	BMP050036/2013355A
115	Assuring Proper Counterbalance Valve Operation-Hydraulic Tilting Washer-Extractors and Centrifugal Extractors	BIPEUM01/20110414
<b>119</b>	<b>7. Control and Sensing Devices</b>	
120	Door Safety Switch Installation	BMP940026/2001204V
<b>123</b>	<b>8. M7E Conveyor Assemblies</b>	
124	Pull-wire Stop Switch	BMP140053/2017336A
126	Conveyor Bed - Extractors for Rear Discharge at 20 Degrees	BMP960022/1996467V
129	Extractor Conveyor - 25 Degree Rear Discharge M7E,M7V,M9V,MXV,MZV,MXT4232C	BMP960023/2017494A
136	Folding Unit - Extractor Conveyors with Rear Discharge	BMP960024/1996473V
139	Extractor Conveyor Right (1997-2016)	BMP190001/2019166A
<b>149</b>	<b>9. Water and Steam Piping and Assemblies</b>	
150	Reuse Tank Assembly	BMP940025/2001204V
152	Servicing Air Cylinders	MSSM0130AE/199313AV
<b>155</b>	<b>10. Pneumatic Piping and Assemblies</b>	
156	Air Cylinder Assemblies	BMP830078/2005525B

# **PELLERIN MILNOR CORPORATION**

# **LIMITED STANDARD WARRANTY**

We warrant to the original purchaser that MILNOR machines including electronic hardware/software (hereafter referred to as "equipment"), will be free from defects in material and workmanship for a period of one year from the date of shipment (unless the time period is specifically extended for certain parts pursuant to a specific MILNOR published extended warranty) from our factory with no operating hour limitation. This warranty is contingent upon the equipment being installed, operated and serviced as specified in the operating manual supplied with the equipment, and operated under normal conditions by competent operators.

Providing we receive written notification of a warranted defect within 30 days of its discovery, we will—at our option—repair or replace the defective part or parts, EX Factory (labor and freight specifically NOT included). We retain the right to require inspection of the parts claimed defective in our factory prior to repairing or replacing same. We will not be responsible, or in any way liable, for unauthorized repairs or service to our equipment, and this warranty shall be void if the equipment is tampered with, modified, or abused, used for purposes not intended in the design and construction of the machine, or is repaired or altered in any way without MILNOR's written consent.

Parts damaged by exposure to weather, to aggressive water, or to chemical attack are not covered by this warranty. For parts which require routine replacement due to normal wear—such as gaskets, contact points, brake and clutch linings, belts, hoses, and similar parts—the warranty time period is 90 days.

We reserve the right to make changes in the design and/or construction of our equipment (including purchased components) without obligation to change any equipment previously supplied.

ANY SALE OR FURNISHING OF ANY EQUIPMENT BY MILNOR IS MADE ONLY UPON THE EXPRESS UNDERSTANDING THAT MILNOR MAKES NO EXPRESSED OR IMPLIED WARRANTIES OF MERCHANTABILITY OR FITNESS FOR ANY PARTICULAR USE OR PURPOSE OR ANY OTHER WARRANTY IMPLIED BY LAW INCLUDING BUT NOT LIMITED TO REDHIBITION. MILNOR WILL NOT BE RESPONSIBLE FOR ANY COSTS OR DAMAGES ACTUALLY INCURRED OR REQUIRED AS A RESULT OF: THE FAILURE OF ANY OTHER PERSON OR ENTITY TO PERFORM ITS RESPONSIBILITIES, FIRE OR OTHER HAZARD, ACCIDENT, IMPROPER STORAGE, MIS-USE, NEGLIGENCE, POWER OR ENVIRONMENTAL CONTROL MALFUNCTIONS, DAMAGE FROM LIQUIDS, OR ANY OTHER CAUSE BEYOND THE NORMAL RANGE OF USE. REGARDLESS OF HOW CAUSED, IN NO EVENT SHALL MILNOR BE LIABLE FOR SPECIAL, INDIRECT, PUNITIVE, LIQUIDATED, OR CONSEQUENTIAL COSTS OR DAMAGES, OR ANY COSTS OR DAMAGES WHATSOEVER WHICH EXCEED THE PRICE PAID TO MILNOR FOR THE EQUIPMENT IT SELLS OR FURNISHES.

THE PROVISIONS ON THIS PAGE REPRESENT THE ONLY WARRANTY FROM MILNOR AND NO OTHER WARRANTY OR CONDITIONS, STATUTORY OR OTHERWISE, SHALL BE IMPLIED.

WE NEITHER ASSUME, NOR AUTHORIZE ANY EMPLOYEE OR OTHER PERSON TO ASSUME FOR US, ANY OTHER RESPONSIBILITY AND/OR LIABILITY IN CONNECTION WITH THE SALE OR FURNISHING OF OUR EQUIPMENT TO ANY BUYER.

BMP720097/19036

## How to Get the Necessary Repair Components



This document uses Simplified Technical English.  
Learn more at <http://www.asd-ste100.org>.

You can get components to repair your machine from the approved supplier where you got this machine. Your supplier will usually have the necessary components in stock. You can also get components from the Milnor® factory.

Tell the supplier the machine model and serial number and this data for each necessary component:

- The component number from this manual
- The component name if known
- The necessary quantity
- The necessary transportation requirements
- If the component is an electrical component, give the schematic number if known.
- If the component is a motor or an electrical control, give the nameplate data from the used component.

To write to the Milnor factory:

Pellerin Milnor Corporation  
Post Office Box 400  
Kenner, LA 70063-0400  
UNITED STATES

Telephone: 504-467-2787  
Fax: 504-469-9777  
Email: [parts@milnor.com](mailto:parts@milnor.com)

— End of BIUUUD19 —

## Trademarks of Pellerin Milnor Corporation

These words are trademarks of Pellerin Milnor Corporation and other entities:

**Table 1: Trademarks**

AutoSpot™	E-P Plus®	Linear Costa Master™	MilTouch™	PurePulse®
CBW®	Gear Guardian®	Linear Costo™	MilTouch-EX™	Ram Command™
Drynet™	GreenTurn™	Mentor®	Miltrac™	RecircONE®
E-P Express®	GreenFlex™	Mildata®	MultiTrac™	RinSave®
E-P OneTouch®	Hydro-cushion™	Milnor®	PBW™	SmoothCoil™
		MilMetrix®	PulseFlow®	Staph Guard®

— End of BIUUUD14 —

## Safety—Centrifugal Extractor

### 1. General Safety Requirements—Vital Information for Management Personnel [Document BIUUUS04]

Incorrect installation, neglected preventive maintenance, abuse, and/or improper repairs, or changes to the machine can cause unsafe operation and personal injuries, such as multiple fractures, amputations, or death. The owner or his selected representative (owner/user) is responsible for understanding and ensuring the proper operation and maintenance of the machine. The owner/user must familiarize himself with the contents of all machine instruction manuals. The owner/user should direct any questions about these instructions to a Milnor® dealer or the Milnor® Service department.

Most regulatory authorities (including OSHA in the USA and CE in Europe) hold the owner/user ultimately responsible for maintaining a safe working environment. Therefore, the owner/user must do or ensure the following:

- recognize all foreseeable safety hazards within his facility and take actions to protect his personnel, equipment, and facility;
- work equipment is suitable, properly adapted, can be used without risks to health or safety, and is adequately maintained;
- where specific hazards are likely to be involved, access to the equipment is restricted to those employees given the task of using it;
- only specifically designated workers carry out repairs, modifications, maintenance, or servicing;
- information, instruction, and training is provided;
- workers and/or their representatives are consulted.

Work equipment must comply with the requirements listed below. The owner/user must verify that installation and maintenance of equipment is performed in such a way as to support these requirements:

- control devices must be visible, identifiable, and marked; be located outside dangerous zones; and not give rise to a hazard due to unintentional operation;
- control systems must be safe and breakdown/damage must not result in danger;
- work equipment is to be stabilized;
- protection against rupture or disintegration of work equipment;
- guarding, to prevent access to danger zones or to stop movements of dangerous parts before the danger zones are reached. Guards to be robust; not give rise to any additional hazards; not be easily removed or rendered inoperative; situated at a sufficient distance from the danger zone; not restrict view of operating cycle; allow fitting, replacing, or maintenance by restricting access to relevant area and without removal of guard/protection device;
- suitable lighting for working and maintenance areas;
- maintenance to be possible when work equipment is shut down. If not possible, then protection measures to be carried out outside danger zones;
- work equipment must be appropriate for preventing the risk of fire or overheating; discharges of gas, dust, liquid, vapor, other substances; explosion of the equipment or substances in it.



- 1.1. **Laundry Facility**—Provide a supporting floor that is strong and rigid enough to support—with a reasonable safety factor and without undue or objectionable deflection—the weight of the fully loaded machine and the forces transmitted by it during operation. Provide sufficient clearance for machine movement. Provide any safety guards, fences, restraints, devices, and verbal and/or posted restrictions necessary to prevent personnel, machines, or other moving machinery from accessing the machine or its path. Provide adequate ventilation to carry away heat and vapors. Ensure service connections to installed machines meet local and national safety standards, especially regarding the electrical disconnect (see the National Electric Code). Prominently post safety information, including signs showing the source of electrical disconnect.
- 1.2. **Personnel**—Inform personnel about hazard avoidance and the importance of care and common sense. Provide personnel with the safety and operating instructions that apply to them. Verify that personnel use proper safety and operating procedures. Verify that personnel understand and abide by the warnings on the machine and precautions in the instruction manuals.
- 1.3. **Safety Devices**—Ensure that no one eliminates or disables any safety device on the machine or in the facility. Do not allow machine to be used with any missing guard, cover, panel or door. Service any failing or malfunctioning device before operating the machine.
- 1.4. **Hazard Information**—Important information on hazards is provided on the machine safety placards, in the Safety Guide, and throughout the other machine manuals. **Placards must be kept clean so that the information is not obscured. They must be replaced immediately if lost or damaged. The Safety Guide and other machine manuals must be available at all times to the appropriate personnel.** See the machine service manual for safety placard part numbers. Contact the Milnor Parts department for replacement placards or manuals.
- 1.5. **Maintenance**—Ensure the machine is inspected and serviced in accordance with the norms of good practice and with the preventive maintenance schedule. Replace belts, pulleys, brake shoes/disks, clutch plates/tires, rollers, seals, alignment guides, etc. before they are severely worn. Immediately investigate any evidence of impending failure and make needed repairs (e.g., cylinder, shell, or frame cracks; drive components such as motors, gear boxes, bearings, etc., whining, grinding, smoking, or becoming abnormally hot; bending or cracking of cylinder, shell, frame, etc.; leaking seals, hoses, valves, etc.) Do not permit service or maintenance by unqualified personnel.

## 2. Safety Alert Messages—Internal Electrical and Mechanical Hazards [Document BIUUUS11]

The following are instructions about hazards inside the machine and in electrical enclosures.



**WARNING 1: Electrocution and Electrical Burn Hazards**—Contact with electric power can kill or seriously injure you. Electric power is present inside the cabinetry unless the main machine power disconnect is off.

- Do not unlock or open electric box doors.
- Do not remove guards, covers, or panels.
- Do not reach into the machine housing or frame.
- Keep yourself and others off of machine.
- Know the location of the main machine disconnect and use it in an emergency to remove all electric power from the machine.



**WARNING 2: Entangle and Crush Hazards**—Contact with moving components normally isolated by guards, covers, and panels, can entangle and crush your limbs. These components move automatically.

- Do not remove guards, covers, or panels.
- Do not reach into the machine housing or frame.
- Keep yourself and others off of machine.
- Know the location of all emergency stop switches, pull cords, and/or kick plates and use them in an emergency to stop machine motion.



**WARNING 3: Crush Hazards**—Tilting machines only—The machine housing will crush your body or limbs if it descends or falls while you are under it. Housing can descend with power off or on. Manual operation of tilting valves overrides safety interlocks. Improper operation of manual tilting valves may cause the housing to descend.

- Do not remove guards, covers, or panels.
- Do not reach into the machine housing or frame.

### 3. Safety Alert Messages—External Mechanical Hazards [Document BIUUUS12]

The following are instructions about hazards around the front, sides, rear or top of the machine.



**WARNING 4: Crush Hazards**—Suspended machines only—Spaces between the shell and housing can close and crush or pinch your limbs. The shell moves within the housing during operation.

- Do not reach into the machine housing or frame.
- Keep yourself and others clear of movement areas and paths.



**WARNING 5: Fall, Entangle, and Strike Hazards**—Machine motion can cause you to fall or become entangled in or struck by nearby objects if you stand, walk, or ride on the machine. Shuttles and conveyor belts move automatically.

- Keep yourself and others off of machine.

### 4. Safety Alert Messages—Cylinder and Processing Hazards

[Document BIUUUS13]

The following are instructions about hazards related to the cylinder and laundering process.



**DANGER 6: Entangle and Sever Hazards**—Contact with goods being processed can cause the goods to wrap around your body or limbs and dismember you.

- Do not attempt to open the door or reach into the cylinder until the cylinder is stopped.
- Do not touch goods inside or hanging partially outside the turning cylinder.
- Know the location of all emergency stop switches, pull cords, and/or kick plates and use them in an emergency to stop machine motion.
- Know the location of the main machine disconnect and use it in an emergency to remove all electric power from the machine.



**WARNING 7: Crush Hazards**—Contact with the turning cylinder can crush your limbs. The cylinder will repel any object you try to stop it with, possibly causing the object to strike or stab you.

- Lock out and tag out power at the main machine disconnect before reaching into the cylinder.
- Do not place any object in the turning cylinder.



**WARNING 8: Confined Space Hazards**—Confinement in the cylinder can kill or injure you. Hazards include but are not limited to panic, burns, poisoning, suffocation, heat prostration, biological contamination, electrocution, and crushing.

- Do not attempt unauthorized servicing, repairs, or modification.



**WARNING 9: Explosion and Fire Hazards**—Flammable substances can explode or ignite in the cylinder, drain trough, or sewer. The machine is designed for washing with water, not any other solvent. Processing can cause solvent-containing goods to give off flammable vapors.

- Do not use flammable solvents in processing.

## 5. Safety Alert Messages—Unsafe Conditions [Document BIUUUS14]

### 5.1. Damage and Malfunction Hazards

#### 5.1.1. Hazards Resulting from Inoperative Safety Devices



**WARNING 10: Multiple Hazards**—Operating the machine with an inoperative safety device can kill or injure personnel, damage or destroy the machine, damage property, and/or void the warranty.

- Do not tamper with or disable any safety device or operate the machine with a malfunctioning safety device. Request authorized service.



**WARNING 11: Electrocution and Electrical Burn Hazards**—Electric box doors—Operating the machine with any electric box door unlocked can expose high voltage conductors inside the box.

- Do not unlock or open electric box doors.



**WARNING 12: Entangle and Crush Hazards**—Guards, covers, and panels—Operating the machine with any guard, cover, or panel removed exposes moving components.

- Do not remove guards, covers, or panels.

#### 5.1.2. Hazards Resulting from Damaged Mechanical Devices



**WARNING 13: Multiple Hazards**—Operating a damaged machine can kill or injure personnel, further damage or destroy the machine, damage property, and/or void the warranty.

- Do not operate a damaged or malfunctioning machine. Request authorized service.



**WARNING 14: Explosion Hazards**—Cylinder—A damaged cylinder can rip apart during extraction, puncturing the shell and discharging metal fragments at high speed.

- Do not operate the machine with any evidence of damage or malfunction.

## 5.2. Careless Use Hazards

### 5.2.1. Careless Operation Hazards—Vital Information for Operator Personnel (see also operator hazards throughout manual)



**WARNING 15: Multiple Hazards**—Careless operator actions can kill or injure personnel, damage or destroy the machine, damage property, and/or void the warranty.

- Do not tamper with or disable any safety device or operate the machine with a malfunctioning safety device. Request authorized service.
- Do not operate a damaged or malfunctioning machine. Request authorized service.
- Do not attempt unauthorized servicing, repairs, or modification.
- Do not use the machine in any manner contrary to the factory instructions.
- Use the machine only for its customary and intended purpose.
- Understand the consequences of operating manually.



**CAUTION 16: Goods Damage and Wasted Resources**—Entering incorrect cake data causes improper processing, routing, and accounting of batches.

- Understand the consequences of entering cake data.

### 5.2.2. Careless Servicing Hazards—Vital Information for Service Personnel (see also service hazards throughout manuals)



**WARNING 17: Electrocutation and Electrical Burn Hazards**—Contact with electric power can kill or seriously injure you. Electric power is present inside the cabinetry unless the main machine power disconnect is off.

- Do not service the machine unless qualified and authorized. You must clearly understand the hazards and how to avoid them.
- Abide by the current OSHA lockout/tagout standard when lockout/tagout is called for in the service instructions. Outside the USA, abide by the OSHA standard in the absence of any other overriding standard.



**WARNING 18: Entangle and Crush Hazards**—Contact with moving components normally isolated by guards, covers, and panels, can entangle and crush your limbs. These components move automatically.

- Do not service the machine unless qualified and authorized. You must clearly understand the hazards and how to avoid them.
- Abide by the current OSHA lockout/tagout standard when lockout/tagout is called for in the service instructions. Outside the USA, abide by the OSHA standard in the absence of any other overriding standard.



**WARNING 19: Crush Hazards**—Tilting machines only—The machine housing will crush your body or limbs if it descends or falls while you are under it. Housing can descend with power off or on. Manual operation of tilting valves overrides safety interlocks. Improper operation of manual tilting valves may cause the housing to descend.

- Secure both red safety supports in accordance with the instructions furnished, then lock out and tag out power at the main machine disconnect before working under the tilted machine.
- Do not operate the manual tilt valves with anyone under the machine.
- Do not operate the tilt controls with anyone under the machine.



**WARNING 20: Confined Space Hazards**—Confinement in the cylinder can kill or injure you. Hazards include but are not limited to panic, burns, poisoning, suffocation, heat prostration, biological contamination, electrocution, and crushing.

- Do not enter the cylinder until it has been thoroughly purged, flushed, drained, cooled, and immobilized.

— End of BIUUUS27 —

## SAFETY ALERT for Owner/Managers and Maintenance Personnel: Using the Access Panel Interlock Bypass Key Switch

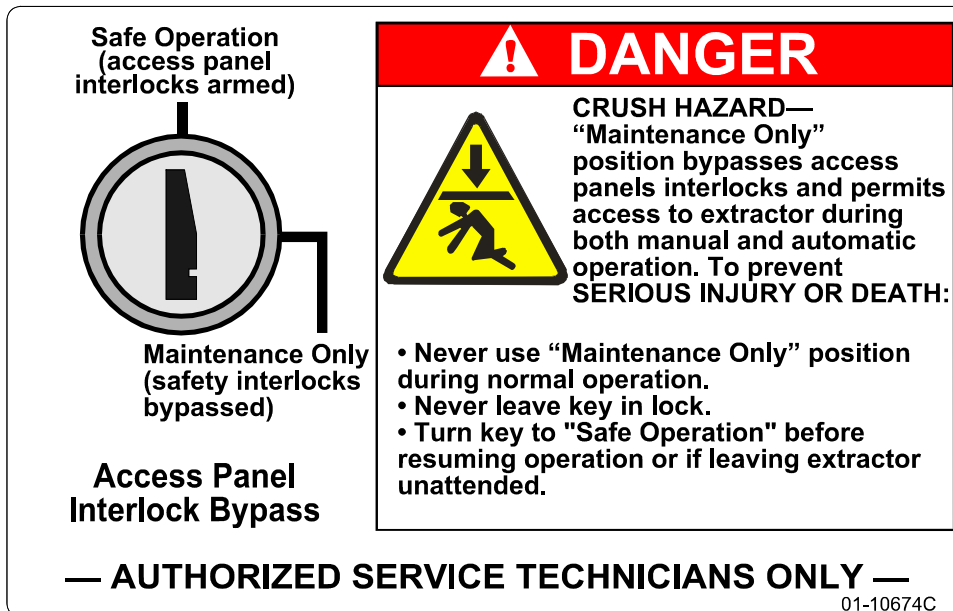
The access panels on this machine are equipped with safety lockout switches that disable the machine if a panel is removed. The Access Panel Interlock Bypass key switch permits bypassing this safety feature to allow access to certain moving parts during required maintenance procedures. This key switch, located inside the low voltage control box, is shown in Figure 1.



**DANGER 1: Crush Hazard**—The “Maintenance Only” position bypasses access panel interlocks and permits access to moving parts during both manual and automatic operation. **To prevent serious injury or death**, comply with, or ensure compliance with the following:

- **Never use the machine for normal operation with this switch in the “Maintenance Only” position.**
- **Never use this switch to clear faults or for any operational function.**
- **Use this switch *only* if you are a trained, authorized service technician**, and only when performing maintenance that requires immediate access to moving parts normally shielded by the access panels.
- Always turn the switch to the “Safe Operation” position **and remove the key** before resuming normal operation or stepping away from the machine.
- Keep the Access Panel Interlock Bypass key secured away from machine operators and all other personnel who do not fully understand the results of using it.
- Keep all electrical and control cabinets closed and securely latched. Keep control cabinet keys away from untrained employees.

Figure 1: Access Panel Bypass Key Switch and Safety Placard



— End of BICP1S01 —

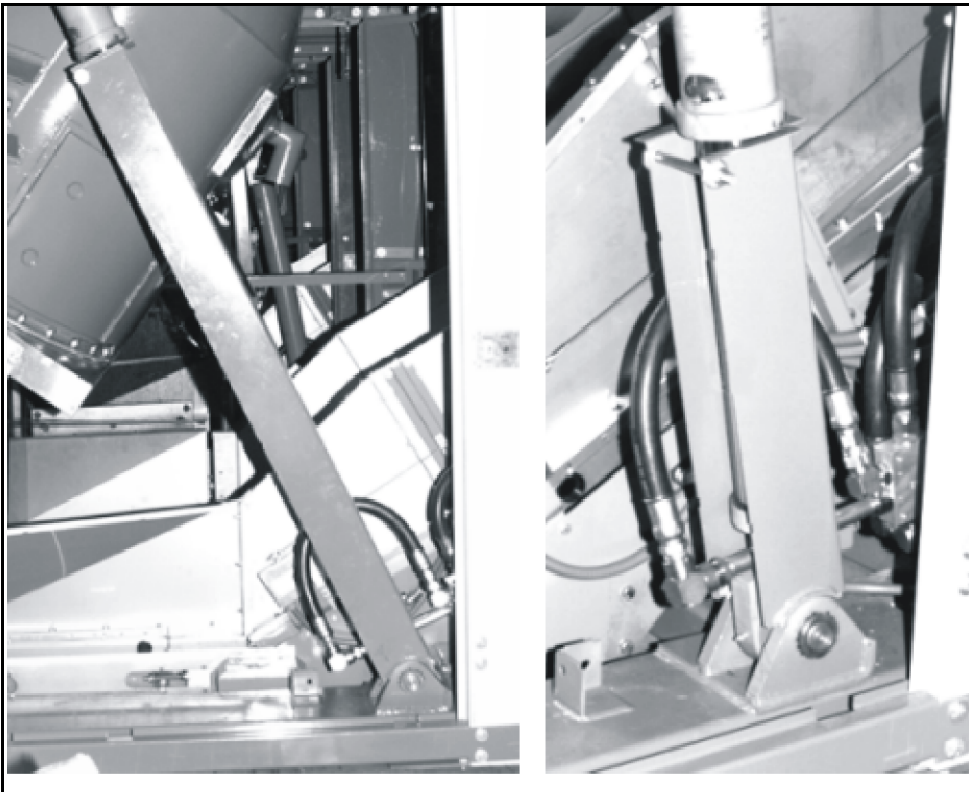
## How To Use the Red Safety Support(s) for Maintenance

### 1. What Safety Supports are Provided and Why

These machines are provided with four safety stands—two short (which also serve as shipping brackets) and two long. After the shell is tilted to the horizontal or full up position, the appropriate stands are placed around the shafts of the extended hydraulic cylinders and secured in position.

Use the safety support(s) whenever the maintenance to be performed requires you to place any part of your body in or near the path of the vertically moving portion of the machine. When not in use, stow the safety supports as explained herein.

**Figure 1: Safety Stands for 42-series Centrifugal Extractor Models**



**WARNING 1: Crush Hazard**—The safety supports provide protection against the drifting down of the vertically moving portion of the machine during maintenance in the event of a leak in the hydraulic system. They are not intended to restrain the machine from coming down under power.

- Never work in or near the path of the vertically moving portion of the machine unless the safety supports are deployed and power is locked out/tagged out.
- Maintain the safety support(s) in good condition.
- Where a pair of safety supports is provided, always use both safety supports.
- Designate a convenient, secure area to stow these safety components when not in use.

## 2. How to Deploy the Safety Support(s)

- 2.1. **Put the Machine In Position to Accept the Safety Support(s)**—At the controls, use the *Manual* mode to raise the shell. Raise the shell only as far as needed to fit the appropriate stands securely.
- 2.2. **Put the Safety Support(s) in Position**—Place the safety stands (long or short, as appropriate) as follows:
  1. Put the stands around the tilt cylinder shafts. Refer to the safety stands parts drawing for a more detailed depiction of the installed stands.
  2. Lock each stand in position with the bolt, nut and washers provided.
- 2.3. **Secure the Safety Support(s) and the Machine**—See [caution statement 2](#) below. At the controls, carefully lower the housing or shell just until it is resting on the stands.

Lock out/tag out power to the machine.



**CAUTION 2: Machine Damage Hazard**—Damage can occur if hydraulic power is applied to the safety stands for an extended time.

- Release the controls as soon as the shell is resting on the stands.

— End of BIUUUS06 —



# Shipping Bracket Installation

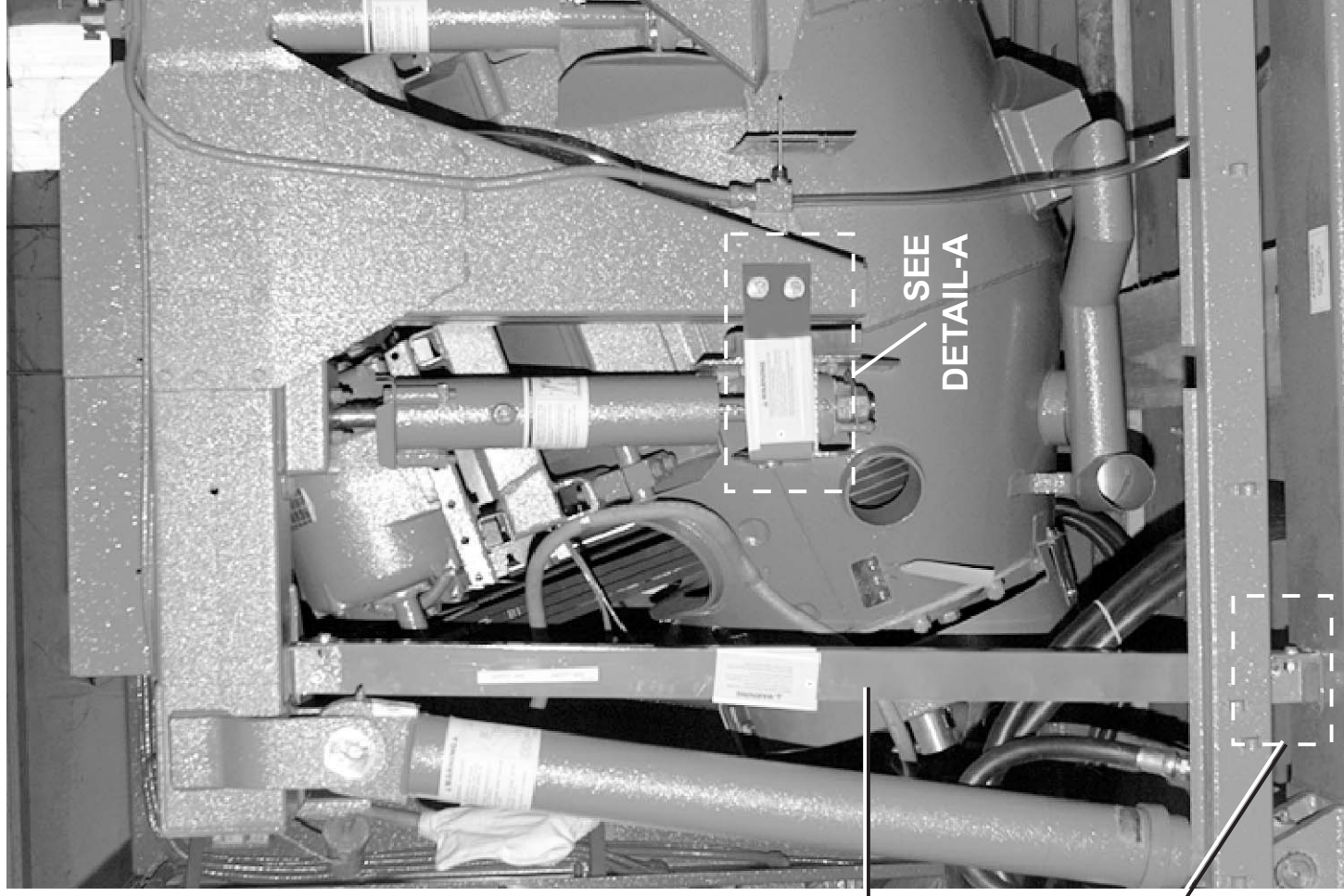
M7E4232C,L,R M9E4232C,L,R M7V4232C,L,R M9V4232C,L,R



**Pellerin Milnor Corporation**  
P. O. Box 400, Kenner, LA 70063-0400

BMP940019/2011152B  
(Sheet 1 of 2)

Litho in U.S.A.

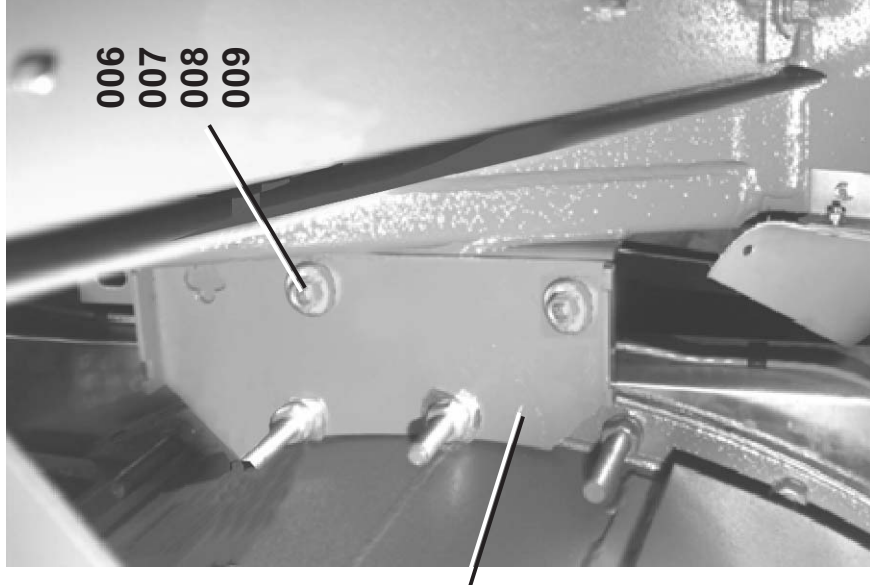


**VERTICAL  
REAR  
SHIPPING  
COLUMNS  
LEFT &  
RIGHT**  
001

**SEE  
DETAIL-B  
TYPICAL  
TOP AND  
BOTTOM**

**SEE  
DETAIL-A**

**LEFT SIDE OF MACHINE SHOWN**



**SHIPPING  
BRACKET  
MOUNTS TO  
SHELLFRONT**

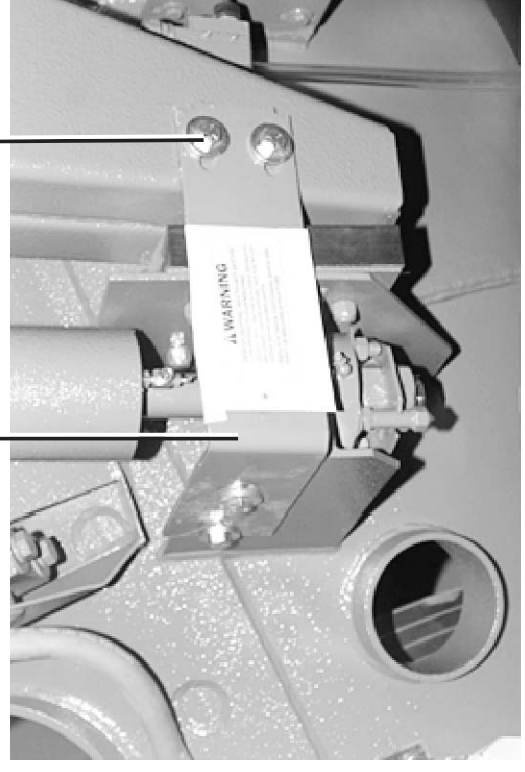
**RIGHT  
SIDE**  
002  
003

006  
007  
008  
009



006  
007  
008  
009

**DETAIL-B**



**004,005  
RIGHT SIDE**

**006,007  
008,009**

**DETAIL-A**



**Pellerin Milnor Corporation**  
P. O. Box 400, Kenner, LA 70063-0400

Litho in U.S.A.

**Parts List—Shipping Bracket Installation**

Find the correct assembly first, then find the needed components. The item letters (A, B, C, etc.) assigned to assemblies are referred to in the "Used In" column to identify which components belong to an assembly. The item numbers (1, 2, 3, etc.) assigned to components relate the parts list to the illustration.

Used In	Item	Part Number	Description	Comments
			-----ASSEMBLIES-----	
	A	GHS16001	INSTL=HOUSE SHIPPING 42M7E	INSTALLATION
			-----COMPONENTS-----	
all	1	03 16300	VERT REAR SHIP COLUMN RT/LFT	
all	2	03 16303	FRONT SHIP MNT BRKT SHELL RT	
all	3	03 16303A	FRONT SHIP MNT BRKT SHELL LF	
all	4	03 16304	MID SHIP BRKT RT	
all	5	03 16304A	MID SHIP BRKT LFT	
all	6	15K147	HXCAPSCR 1/2-13UNC2X1 GR5 ZINC	
all	7	15G230	HXNUT 1/2-13UNC2B SAE ZINC GR2	
all	8	15U300	LOKWASHER REGULAR 1/2 ZINC PLT	
all	9	15U280	FL+WASHER(USS STD)1/2 ZNC PL+D	

# Safety Stand Installation

M7E4232C,L,R M9E4232C,L,R M7V4232C,L,R M9V4232C,L,R

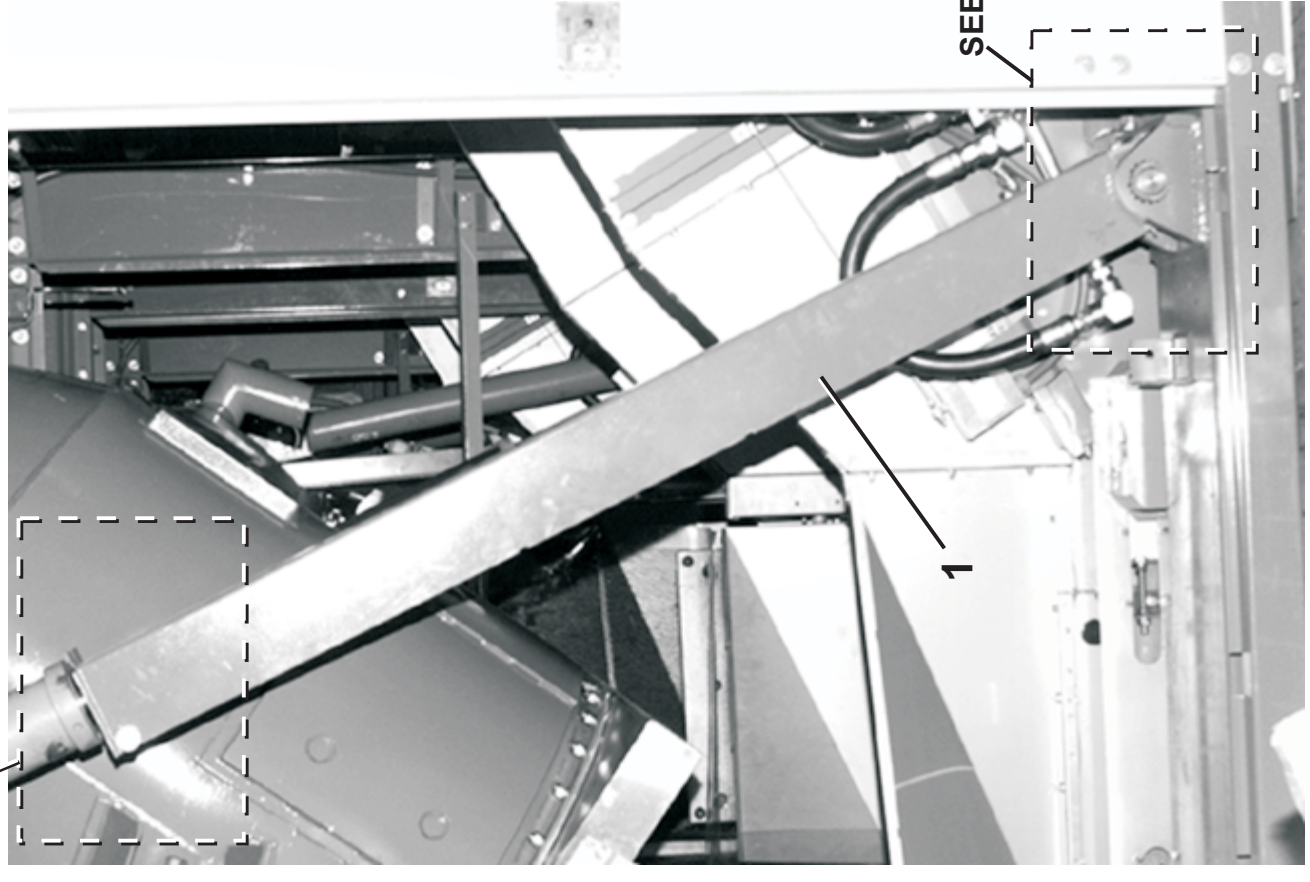


**Pellerin Milnor Corporation**  
P. O. Box 400, Kenner, LA 70063-0400

BMP940028/2011105B  
(Sheet 1 of 2)

Litho in U.S.A.

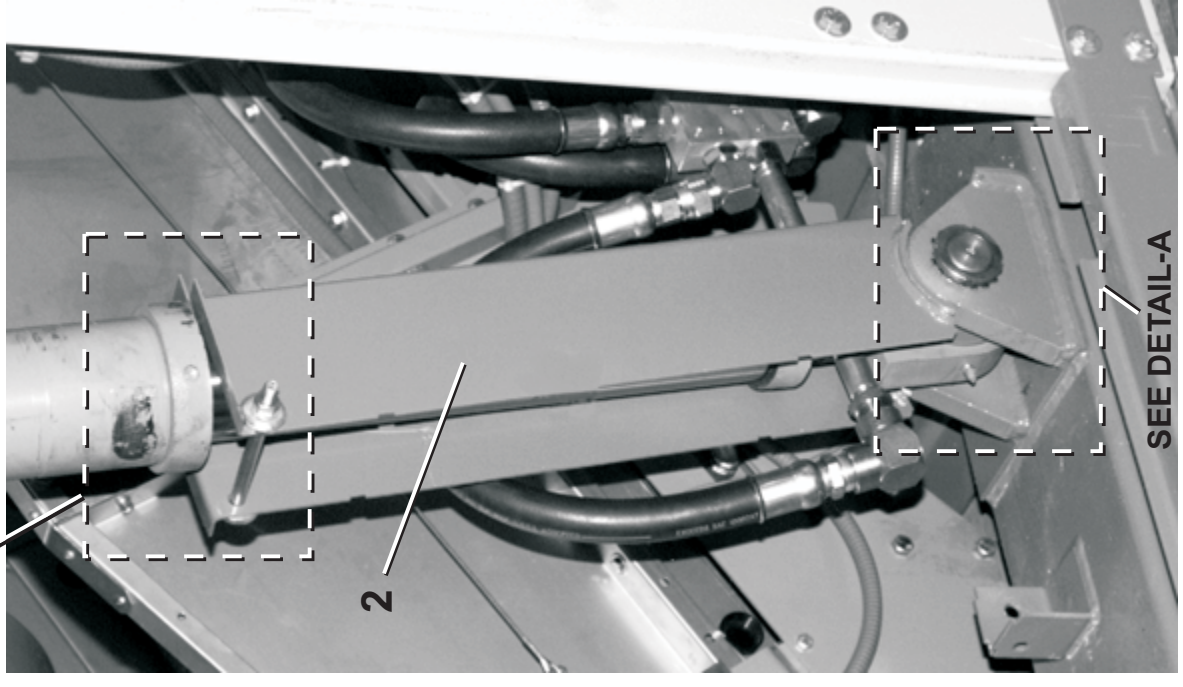
SEE DETAIL-B



SEE DETAIL-A

USED ON BOTH SIDES OF MACHINE

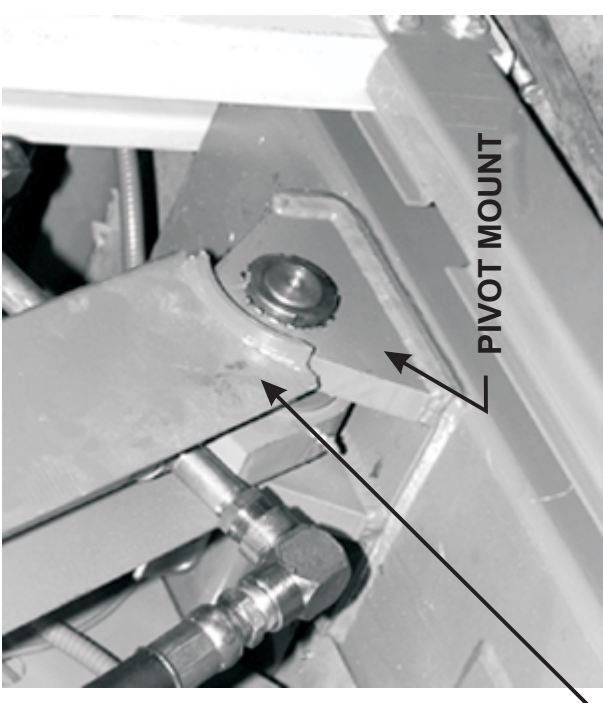
SEE DETAIL-B



SEE DETAIL-A

USED ON BOTH SIDES OF MACHINE

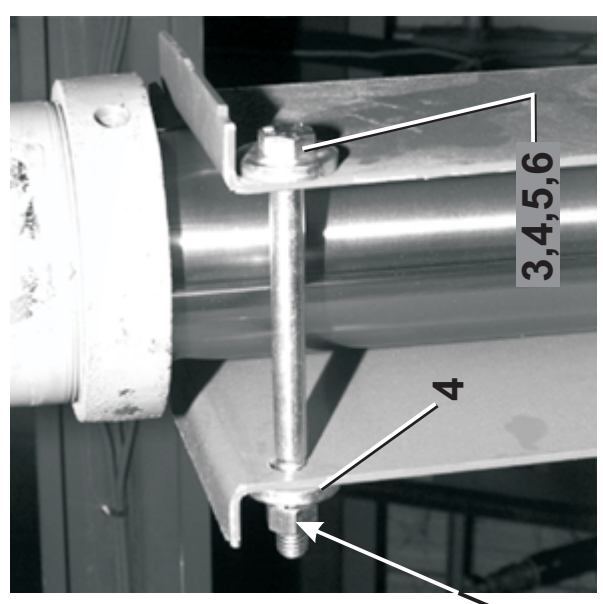
DETAIL-A



PIVOT MOUNT

WHEN INSTALLING THE SAFETY STANDS, INSURE THE ROUNDED EDGE OF THE STAND IS RESTING PROPERLY AGAINST THE PIVOT MOUNT.

DETAIL-B



4

3,4,5,6

INSURE THE FACTORY-SUPPLIED HARDWARE IS FASTENED PROPERLY AS SHOWN HERE



Pellerin Milnor Corporation  
P. O. Box 400, Kenner, LA 70063-0400

Litho in U.S.A.

**Parts List— Safety Stand Installation**

Find the correct assembly first, then find the needed components. The item letters (A, B, C, etc.) assigned to assemblies are referred to in the "Used In" column to identify which components belong to an assembly. The item numbers (1, 2, 3, etc.) assigned to components relate the parts list to the illustration.

Used In	Item	Part Number	Description	Comments
-----ASSEMBLIES-----				
	A	GG516002	SAFETY STAND LARGE 42M7E	LARGE
	B	GG516005	SAFETY STAND SMALL 42M7E	SMALL
-----COMPONENTS-----				
A	1	W3 16325	*WLDMT= LARGE SAFETY STAND	
B	2	W3 16324	*WLDMT= SMALL SAFETY STAND	
all	3	15K203D	HXCAPSCR 1/2-13X5.5UNC2A GR5 P	
all	4	15U280	FL+WASHER(USS STD)1/2 ZNC PL+D	
all	5	15U300	LOKWASHER REGULAR 1/2 ZINC PLT	
all	6	15G230	HXNUT 1/2-13UNC2B SAE ZINC GR2	

## About the Forces Transmitted by Milnor® Washer-extractors

During washing and extracting, all washer-extractors transmit both static and dynamic (cyclic) forces to the floor, foundation, or any other supporting structure. During washing, the impact of the goods as they drop imparts forces which are quite difficult to quantify. Size for size, both rigid and flexibly-mounted machines transmit approximately the same forces during washing. During extracting, rigid machines transmit forces up to 30 times greater than equivalent flexibly-mounted models. The actual magnitude of these forces vary according to several factors:

- machine size,
- final extraction speed,
- amount, condition, and type of goods being processed,
- the liquor level and chemical conditions in the bath preceding extraction, and
- other miscellaneous factors.

Estimates of the maximum force normally encountered are available for each Milnor® model and size upon request. Floor or foundation sizes shown on any Milnor® document are only for on-grade situations based only on previous experience without implying any warranty, obligation, or responsibility on our part.

### 1. Rigid Machines

Size for size, rigid washer-extractors naturally require a stronger, more rigid floor, foundation, or other supporting structure than flexibly-mounted models. If the supporting soil under the slab is itself strong and rigid enough and has not subsided to leave the floor slab suspended without support, on grade installations can often be made directly to an existing floor slab if it has enough strength and rigidity to safely withstand our published forces without transmitting undue vibration. If the subsoil has subsided, or if the floor slab itself has insufficient strength and rigidity, a deeper foundation, poured as to become monolithic with the floor slab, may be required. Support pilings may even be required if the subsoil itself is “springy” (i.e., if its resonant frequency is near the operating speed of the machine). Above-grade installations of rigid machines also require a sufficiently strong and rigid floor or other supporting structure as described below.

### 2. Flexibly-mounted Machines

Size for size, flexibly-mounted machines generally do not require as strong a floor, foundation, or other supporting structure as do rigid machines. However, a floor or other supporting structure having sufficient strength and rigidity, as described in [Section 3](#), is nonetheless vitally important for these models as well.

### 3. How Strong and Rigid?

Many building codes in the U.S.A. specify that laundry floors must have a minimum live load capacity of 150 pounds per square foot (732 kilograms per square meter). However, even compliance with this or any other standard does not necessarily guarantee sufficient rigidity. In any event, it is the sole responsibility of the owner/user to assure that the floor and/or any other supporting structure exceeds not only all applicable building codes, but also that the floor and/or any other supporting structure for each washer-extractor or group of washer-extractors actually has sufficient strength and rigidity, plus a reasonable factor of safety for both, to support the weight of all the fully loaded machine(s) including the weight of the water and goods, and including the published 360° rotating sinusoidal RMS forces that are transmitted by the machine(s). Moreover, the floor, foundation, or other supporting structure must have sufficient

rigidity (i.e., a natural or resonant frequency many times greater than the machine speed with a reasonable factor of safety); otherwise, the mentioned 360° rotating sinusoidal RMS forces can be multiplied and magnified many times. It is especially important to consider all potential vibration problems that might occur due to all possible combinations of forcing frequencies (rotating speeds) of the machine(s) compared to the natural frequencies of the floor and/or any other supporting structure(s). A qualified soil and/or structural engineer must be engaged for this purpose.

**Figure 1: How Rotating Forces Act on the Foundation**

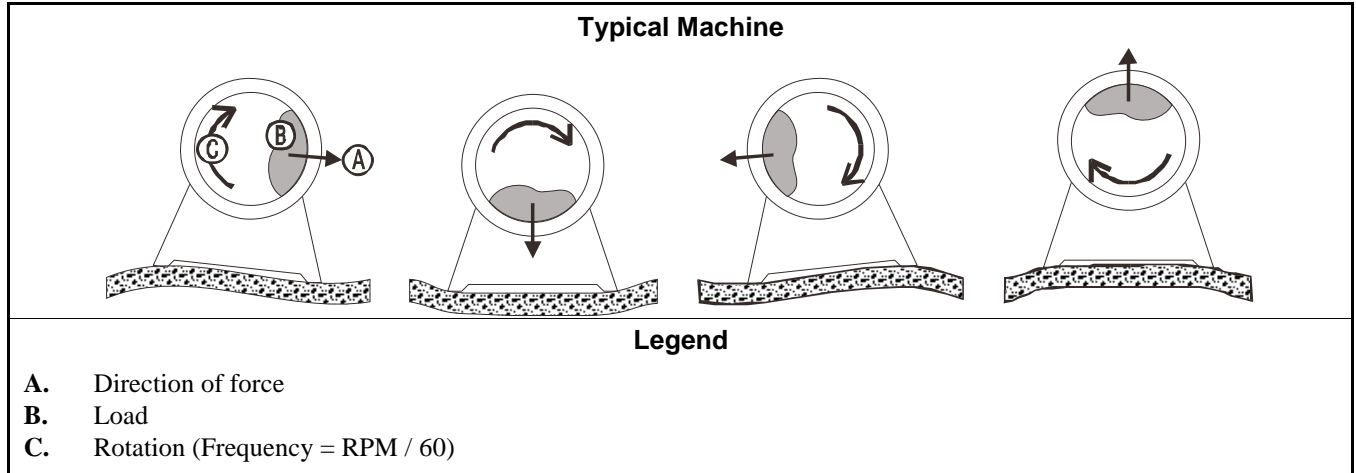


Figure 1 above is intended to depict both on-grade and above-grade installations and is equally applicable to flexibly-mounted washer-extractors, as well as to rigid models installed either directly on a floor slab or on a foundation poured integrally with the slab. Current machine data is available from Milnor® upon request. All data is subject to change without notice and may have changed since last printed. It is the sole responsibility of every potential owner to obtain written confirmation that any data furnished by Milnor® applies for the model(s) and serial number(s) of the specific machines.

— End of BIWUI02 —

BIUUUI02PE (Published) Book specs- Dates: 20160712 / 20160712 / 20160712 Lang: ENG01 Applic: PEU

## Tag Guidelines for the Models Listed Below

M7V4232C	M7V4232L	M7V4232R	M7V4836C	M7V4836L	M7V4836R	M7V4840C
M9S4232C	M9S4232L	M9S4232R	M9V4232C	M9V4232L	M9V4232R	M9V4840C
M9V4840L	M9V4840R	MMS4232C	MMS4232L	MMS4232R	MMV4232C	MMV4232L
MMV4232R	MXS4232C	MXS4232L	MXS4232R	MXV4232C	MXV4232L	MXV4232R

**Notice 1:** This information may apply to models in addition to those listed above. It applies to paper tags. It does not apply to the vinyl or metal safety placards, which must remain permanently affixed to the machine and replaced if no longer readable.

Paper tags on the machine provide installation guidelines and precautions. The tags can be tie-on or adhesive. You can remove tie-on tags and white, adhesive tags after installation. Yellow adhesive tags must remain on the machine.

Tag Guidelines for the Models Listed Below

The following entries explain the installation tags. Each entry includes: 1) the tag illustration, 2) the tag part number displayed at the bottom of the tag, and 3) the meaning of the tag.

**Display or Action**



**Explanation**

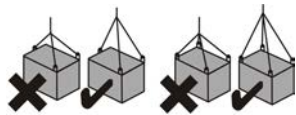
Read the manuals before proceeding. This symbol appears on most tags. The machine ships with safety, operator, and routine maintenance guides for customer use. Milnor dealer manuals for installing, servicing, and commissioning this machine are also available from the Milnor Parts department.



B2TAG88005: This carefully built product was tested and inspected to meet Milnor® performance and quality standards by (identification mark of tester).



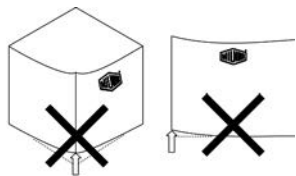
B2TAG94078: Do not forklift here; do not jack here; do not step here—whichever applies.



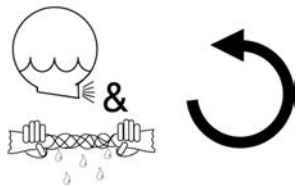
B2TAG94079: Rig for crane lifting (either 3-point or 4-point, depending on the number of lifting eyes provided) using a steep angle on the chains (closer to vertical than horizontal).



B2TAG94081: Motor must rotate in this direction. On single motor washer-extractors and centrifugal extractors, the drive motor must turn in this direction during draining and extraction. This tag is usually wrapped around a motor housing. If the motor turns in the opposite direction when the machine is first tested, the electrical hookup is incorrect and must be reversed as explained in the schematic manual.



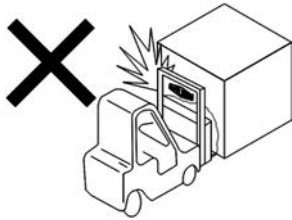
B2TAG94084: Do not lift from one corner of the machine, as this can cause the frame to rack, damaging it.



B2TAG94097: The cylinder must rotate **counterclockwise** during draining and extraction (spin) when viewed from here (rear of machine). Otherwise, reverse the electric power connections, as explained in the schematic manual.

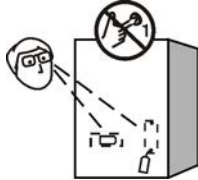


**Display or Action**



**Explanation**

B2TAG94118: Do not strike shipping container during fork-lifting. Fragile components inside.



B2T2001028: Look for tags inside the machine. These tags may identify shipping restraints to be removed or components to be installed. Do not start the machine until these actions are completed.



B2T2002013: Do not start the machine until shipping restraints are removed. This tag will appear on the outside of the machine to alert you to the presence of internal shipping restraints. A tag will also appear on the restraint to help identify it. Most, but not all shipping restraints display the color red. Some shipping restraints are also safety stands. Do not discard these.

— End of BIUUUI02 —

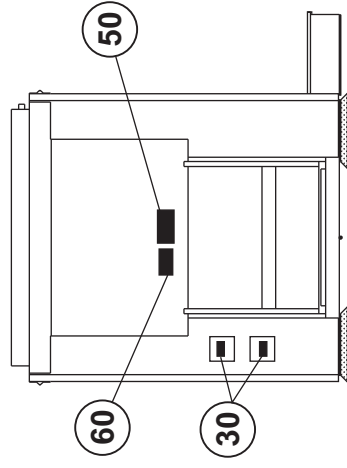


**Pellerin Milnor Corporation**  
P. O. Box 400, Kenner, LA 70063-0400

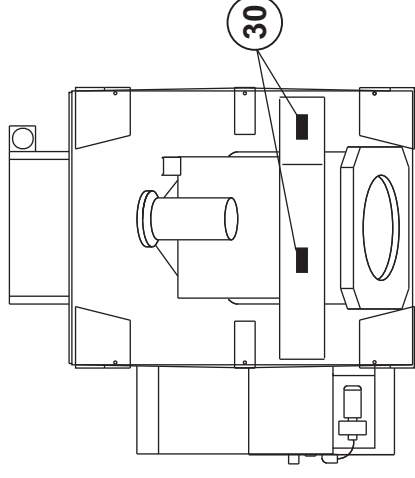
Litho in U.S.A.

**Notes:**

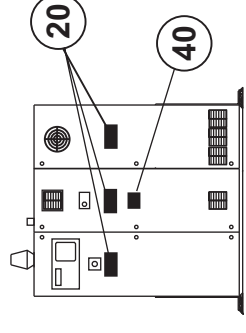
1. Replace placard immediately, if removed or unreadable.
2. Approximate locations of placards are shown. Mounting holes are provided on machine. If aluminum placard use #8 self-tapping screws.



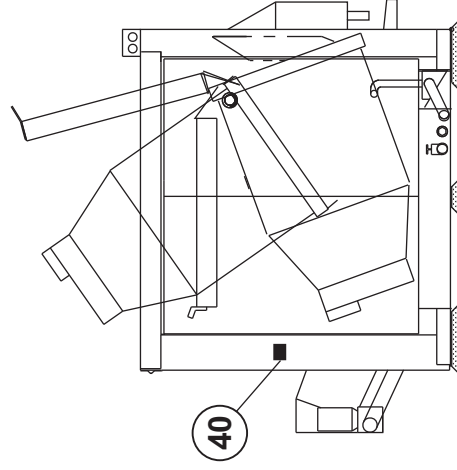
REAR VIEW



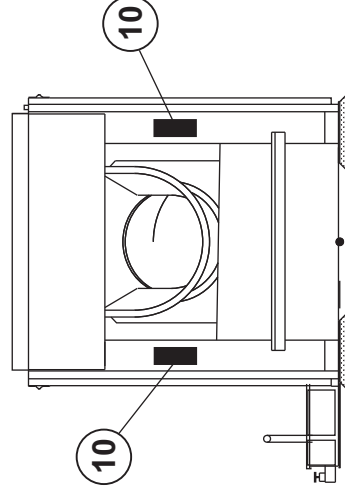
PLAN VIEW



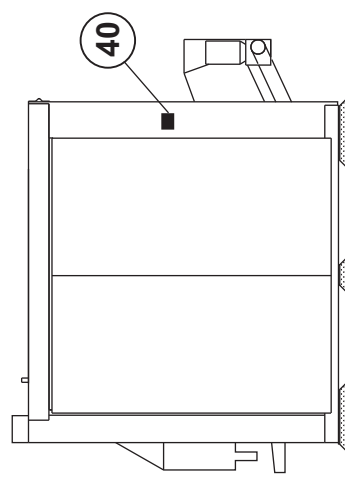
CONTROLS  
FRONT VIEW



LEFT VIEW



FRONT (LOAD END) VIEW



RIGHT VIEW



**Pellerin Milnor Corporation**  
P. O. Box 400, Kenner, LA 70063-0400

Litho in U.S.A.

**Parts List—Safety Placard Placement**

Find the correct assembly first, then find the needed components. The item letters (A, B, C, etc.) assigned to assemblies are referred to in the "Used In" column to identify which components belong to an assembly. The item numbers (1, 2, 3, etc.) assigned to components relate the parts list to the illustration.

Used In	Item	Part Number	Description	Comments
			-----ASSEMBLIES----- none	
			-----COMPONENTS-----	
all	10	01 10583A	NPLT:64/72 W/E WARN FRT-TCATA	
all	20	01 10377A	NPLT:ELEC HAZARD LG-TCATA	
all	30	01 10375B	NPLT:ELEC HAZARD SMALL-TCATA	
all	40	01 10699B	NPLT:SERV HZRD-ALUM-TCATA	
all	50	01 10634A	NPLT:CONVEYOR HAZARDS-TCATA	
all	60	01 10630A	NPLT:TILT CRUSH HAZARD-TCATA	



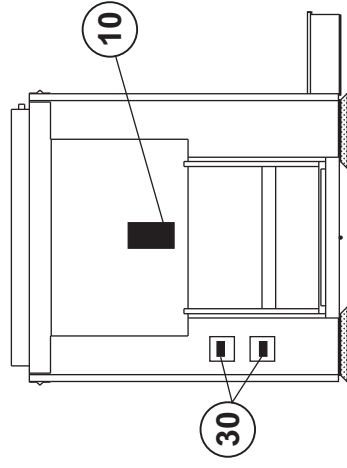
Pellerin Milnor Corporation  
P. O. Box 400, Kenner, LA 70063-0400

Litho in U.S.A.

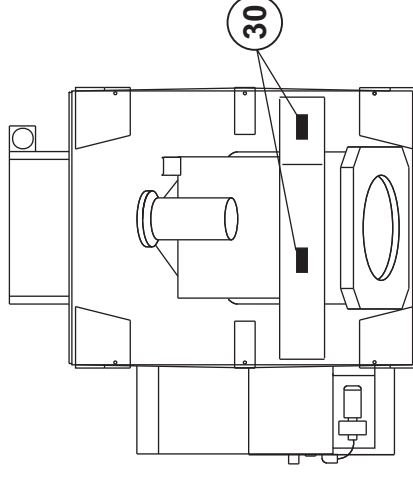
## ISO Placards shown on this page

### Notes:

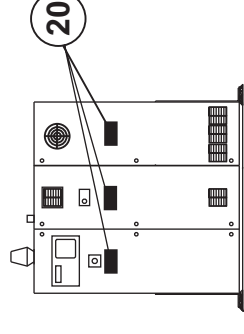
1. Replace placard immediately, if removed or unreadable.
2. Approximate locations of placards are shown. Mounting holes are provided on machine. If aluminum placard use #8 self-tapping screws.



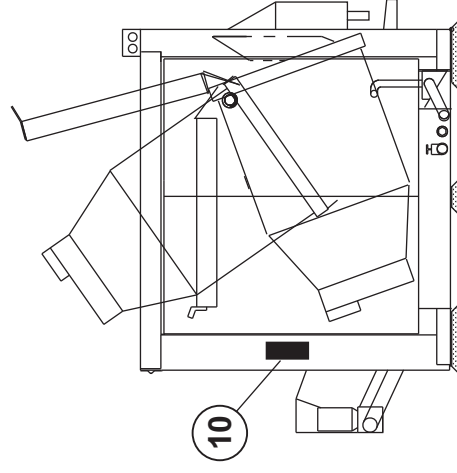
REAR VIEW



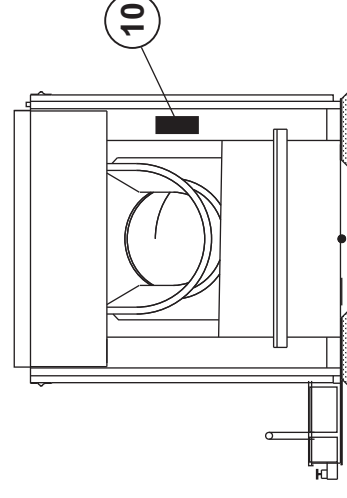
PLAN VIEW



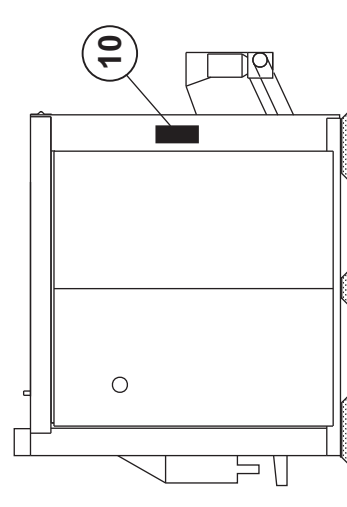
CONTROLS  
FRONT VIEW



LEFT VIEW



FRONT (LOAD END) VIEW



RIGHT VIEW



**Pellerin Milnor Corporation**  
P. O. Box 400, Kenner, LA 70063-0400

Litho in U.S.A.

**Parts List—Safety Placard Placement**

Find the correct assembly first, then find the needed components. The item letters (A, B, C, etc.) assigned to assemblies are referred to in the "Used In" column to identify which components belong to an assembly. The item numbers (1, 2, 3, etc.) assigned to components relate the parts list to the illustration.

Used In	Item	Part Number	Description	Comments
-----ASSEMBLIES-----				
none				
-----COMPONENTS-----				
all	10	01 10588X	NPLT:M7E EXTRACTOR WARNG ISO	
all	20	01 10377	NPLTE:"WARNING" 4X4	
all	30	01 10375	NPLTE:"WARNING" 2X2	



# Service and Maintenance

1

BIPV7M01 (Published) Book specs- Dates: 20040324 / 20040324 / 20040324 Lang: ENG01 Applic: PV7

## Centrifugal Extractor Preventive Maintenance

As required by warranty, and to achieve optimum performance and service life from your Milnor machine, your machine must be maintained in strict accordance with this instruction.

### 1. Lubrication Precautions [Document BIUUUM01]



**CAUTION [1]: Machine Damage Hazard**—Improper lubrication can damage machine components and cause the machine to malfunction.

- Do not mix petroleum and synthetic based lubricants.
- Do not use an unspecified lubricant without consulting the lubricant manufacturer.
- Do not apply grease with a pneumatic grease gun. Use only a hand-operated grease gun.
- Do not over-lubricate.
- Always clean grease fittings before adding grease. Clean off excess grease.
- Ensure that lubricants do not drip onto belts, brake shoes or drums.



**WARNING [2]: Entangle and Crush Hazards**—Contact with moving components normally isolated by guards, covers, and panels, can entangle and crush your limbs. These components move automatically.

- Lock out and tag out power at the main machine disconnect before servicing, or in accordance with factory service procedures.
- Do not service machine unless qualified and authorized.

**1.1. Pumping Grease**—Pump grease slowly, taking 10-12 seconds to complete each stroke. A grease gun can build up extremely high pressure which will force seals out of position and cause them to leak.

**1.2. Grease Quantity**—Apply the quantity of grease called for in the checklist. Over-lubrication can be as damaging as under-lubrication. Where quantities are stated in strokes, one stroke of the grease gun is assumed to provide .0624 fluid oz. (1.77 grams) (by volume) of grease. Therefore, one fluid ounce (28.3 grams) of grease would be provided by 16 stokes of the grease gun. Determine the flow rate of your grease gun by pumping one ounce into a calibrated container. If fewer than 16 stokes are required, all quantities in strokes in the chart should be reduced accordingly, and if more than 16 strokes are required, the number of strokes should be increased. Before starting lubrication, make sure your grease gun is working and that you get a full charge of grease with every stroke.

**1.3. Greasing Seals and Bearings**—Grease seals and bearings with the cylinder turning at wash speed.



**WARNING [3]: Entangle and Crush Hazards**—Contact with moving components normally isolated by guards, covers, and panels, can entangle and crush your limbs. These components move automatically.

- Use extreme care when working near moving components.

Grease seals and main bearing as follows:

1. Locate the seal and bearing grease fittings.
2. Enable the clockwise wash output as described in the reference manual.



3. With the cylinder turning, grease the seals and bearings as called for on the “Preventive Maintenance Checklist.”

**1.4. Lubricant Specifications**—Lubricant specifications are provided in the preventive maintenance checklist. Lubricants should be purchased locally. If a specified lubricant is not available locally, it is permissible to substitute a product that has been specified as equivalent by the lubricant manufacturer. If you cannot obtain either the specified lubricant or a valid equivalent locally, contact the Milnor Service Department for assistance.

## 2. Centrifugal extractor main bearing and seal greasing instructions



**WARNING 4: Entangle and Crush Hazards**—“Bypass door interlocks” position bypasses door interlocks and permits access to extractor during both manual and automatic operation. To prevent **SERIOUS INJURY OR DEATH**:

- Use extreme care when working near moving components.
- Never use “Bypass door interlocks” position during normal operation.

Although centrifugal extractors follow the same general seal and bearing grease instructions stated above, they are equipped with a “bypass door switch” (Figure 1), and require a slightly different procedure as follows:

1. Lock out and tag out power to the machine at the wall disconnect.
2. Locate the bypass door switch in the belt box.
3. Move switch to the “By pass door interlocks” position.
4. Remove left side cosmetic door (as viewed from front of machine).
5. Restore power and place machine in a wash step.
6. With cylinder turning, grease the bearings and seals as called for on the “Preventive Maintenance Checklist.”
7. Lock out and tag off power at the wall disconnect.
8. Replace the door and return bypass switch to automatic.
9. Restore power and resume normal operations.

**Figure 1: Bypass door switch**



### 3. Centrifugal Extractor Preventive Maintenance

Table 1: Lubricant specifications

Assembly	Components	Specifications
<b>Main bearing (Figure 3)</b>	Seals and bearings	Shell Alvania EP (or equivalent)
<b>Hydraulic system (Figures 2 and 4)</b>	Pivot, hydraulic cylinder and pump grease fittings	Shell Alvania EP (or equivalent)
	Hydraulic fluid reservoir	Shell Tellus 68 (or equivalent)
<b>Hydrocushions (Figure 2)</b>	M7V Cylinder oil	Shell Turbo 220 (or equivalent)
	M9V Cylinder oil	Shell Tellus 32 (or equivalent)
	Grease fittings	Shell Alvania EP (or equivalent)
<b>Motor (Figure 2)</b>	Motor bearing grease fittings (if so equipped)	Shell Alvania EP (or equivalent)
<b>Brake (Figure 3)</b>	Brake reservoir	DOT 3 brake fluid
<b>Conveyor</b>	Grease fittings	Shell Alvania EP (or equivalent)
<b>Optional inflatable ribs (Figure 8)</b>	Rotary coupling	Chevron SRI

**Table 2: Centrifugal Extractor Preventive Maintenance Checklist**

<b>Components</b>	<b>Action</b>	<b>Frequency (hours of operation)</b>	<b>Figure</b>
<b>General</b>			
<b>Entire machine</b>	Remove soil build-up	Monthly/200 hours	
<b>Motor</b>			
<b>Extract motor (if equipped with grease fittings)</b>	See Note 1 below		Figure 2
<b>Hydrocushions</b>			
<b>Cylinders</b>	Check oil level at plug, add oil if required	Once every 3 months	Figure 2
	Drain and fill	Annually	
<b>Upper and lower ball joint grease fittings</b>	0.12 ounces (3.54 grams), two strokes at eight locations	Monthly	
<b>Drive belts and pulley sheaves</b>			
<b>Drive belts and pulley sheaves</b>	Check belt tension and wear, replace as required (See Notes 3 and 4)	Monthly (See Table 3)	Figure 2
<b>Bearing Housing</b>			
<b>Front bearing grease fittings</b>	Slowly grease: 0.62 ounces (17.7 grams), ten strokes at one location	Monthly (See "Centrifugal extractor main bearing and seal greasing instructions," above and Note 2 below)	Figure 3
<b>Rear bearing grease fittings</b>	Slowly grease: 0.31 ounces (8.8 grams), five strokes at one location		
<b>Seals</b>	Slowly grease: 0.19 ounces (5.31 grams), three strokes at one location		
<b>Foundation</b>			
<b>Anchor bolts and grout</b>	Inspect anchor bolts and grout	Monthly	
<b>Brake</b>			
<b>Pads</b>	Check for wear, replace as required	Monthly	Figure 3
<b>Reservoir</b>	Check levels, add fluid as required		
<b>Hydraulic components</b>			
<b>Pivot</b>	0.12 ounces (3.54 grams), two strokes at two locations	Monthly	Figure 2
<b>Hydraulic cylinders</b>	0.12 ounces (3.54 grams), two strokes at six locations	Monthly	
<b>Shell stops</b>	Check for wear, replace as required	Semi-annually	

Components	Action	Frequency (hours of operation)	Figure
<b>Reservoir level and temperature gauge</b>	Check level, add if below black mark on gauge (non-tilted), operating temperature (120-130 F) (49-54 C)	Daily	Figure 4
<b>Reservoir</b>	Replace fluid, 60 U.S. Gallons (227.12 Liters)	Annually	Figure 4
<b>Filter</b>	Replace	Semi-annually	Figure 4
<b>Filter pressure gauge</b>	Check pressure with machine tilted, 30 - 60 psi (2 - 4 Bar)	Daily	Figure 4
<b>Line pressure gauge</b>	Check pressure with machine tilted, 400-600 psi (27.5 - 41.3 Bar)	Daily	
<b>All hoses/couplings</b>	Check for leaks, cracks and bulges	Monthly	
<b>Pump</b>	See Note 1 below		
<b>Reuse water systems</b>			
<b>Drip pan and tank strainer</b>	Check and clean	Daily	Figure 5
<b>Reuse pump strainer</b>		Weekly	
<b>Drains</b>			
<b>Load chute drain</b>	Check and clean	Daily	Figure 5
<b>Conveyor components</b>			
<b>Bearings</b>	0.12 ounces (3.54 grams), two strokes at nine locations	Monthly	Figure 6
<b>Drive chain</b>	Inspect chain and gears for wear and lubrication	Monthly	Figure 7
<b>Belt</b>	Check belt tracking, slipping and general condition	Daily	Figure 6
<b>Optional inflatable rib</b>			
<b>Rotary coupling</b>	0.12 ounces (3.54 grams), two strokes	Once every 3 months (See Note 5)	Figure 8
<b>Diffusion bag</b>	Clean	Once every 3 months	
<b>Inflatable rib</b>	Check for cracks in ribs	Weekly	
<b>Muffler</b>	Visually inspect for rust particles, replace as needed	Once every 3 months	
	Check air pressure. Replace muffler if required. (See Note 6)	Bi-annually	

**Note 1:** See "BALDOR MOTOR MAINTENANCE"...MSSM0274AE, in this manual. If motor manufacturers instructions conflict with manual section above, follow the manufacturers instructions. Motors are warranted by the manufacturers, not Milnor.

**Note 2:** The main bearings are prepacked with lubricant at the factory. Do not add grease for the first 30 days of operation. During the first month of operation and every time the bearings are re-lubricated, surplus grease will seep out of the spring loaded relief fittings after a few hours running time. This is normal. Relief

## Centrifugal Extractor Preventive Maintenance

fittings permit excess grease to escape, preventing over-heating problems. Do not replace this excess lubricant. Normal bearings can run hot enough to make it very uncomfortable for a person to hold his hand on the bearing housing for more than a few seconds.

**Note 3:** Check and tighten the drive V-belts (if required);  
 After the first 24 hours of operation (three 8 hour days).  
 After the first 80 hours of operation (ten 8 hour days).  
 After the first 160 hours of operation (twenty 8 hour days).

**Note 4:** All V-belts are not alike. “Super” or “High Capacity” V-belts may have considerably higher capacities than “Standard” belts. Sometimes, a particular manufacturer's V-belts is more suitable for a certain application than another manufacturer, in spite of the fact that both manufacturer's V-belts are reputedly “interchangeable.” Because of this, it is best to purchase replacement belts from the original manufacturer of the equipment. If you do not wish to do this, we suggest that when you replace the belts, you purchase the exact style and type belts with which the machine was originally equipped. This is the best way to achieve belt life on your replacement belts equal to the life of the original belt. (If you are not satisfied with the life of the original set, you should ask our factory if a better belt has been developed for the specific application).

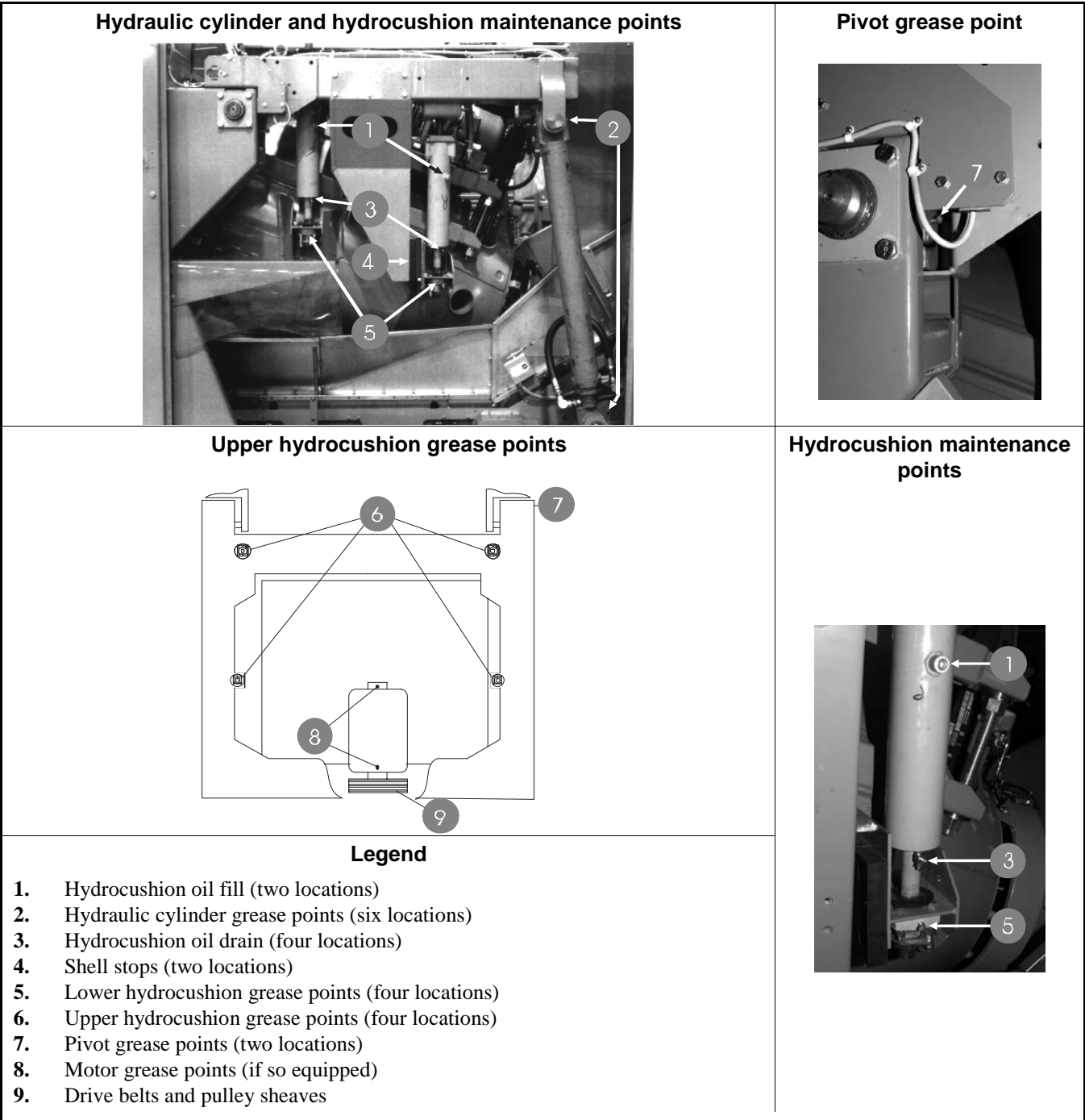
**Note 5:** Rotating unions equipped with grease fittings should be lubricated with a good quality ball bearing grease. We recommend Chevron Oil Company SRI grease for temperatures up to 350 F (177 C). Only enough grease should be applied to the ball bearings to replace that which has been dissipated. Over-greasing can be as damaging to the union as under-greasing. Particularly in high RPM applications, grease should be used sparingly.

**Note 6:** A relief valve in the rib inflation circuit prevents rib damage by bleeding off excess air pressure through a muffler. Test the relief valve by connecting a manometer to the “T” as shown in Figure 8. Verify that the manometer indicates 3.5 - 4.5 inches when the ribs are inflated. Pressures beyond this indicate that the muffler is clogged and must be replaced.

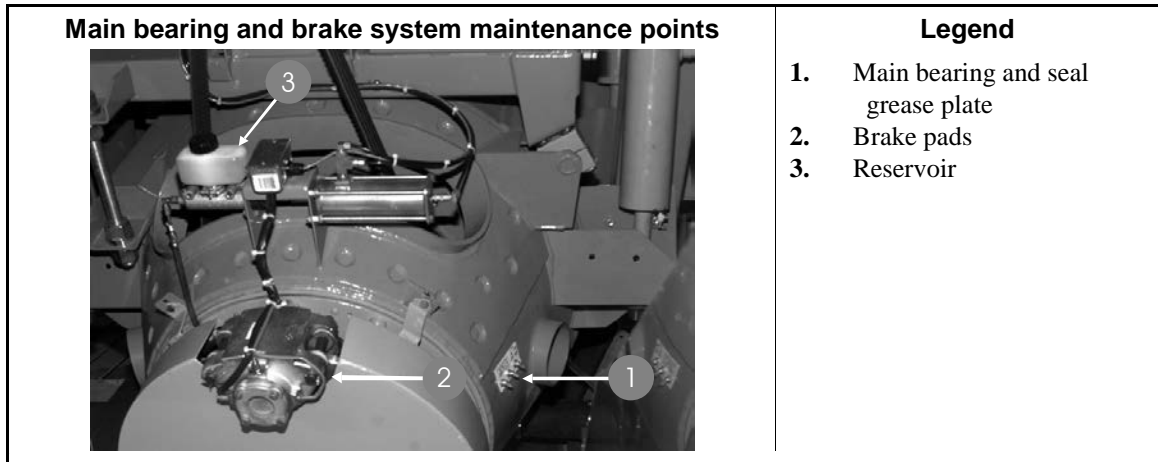
**Table 3: Belt Tension Specifications**

Belt	Hertz	Deflection (inches)	Initial tension (pounds)	Final tension (pounds)
Main	50 Hz	31/64	10.5 - 14.3	8.1 - 11.0
	60 Hz	15/32		

Figure 2: Hydraulic, Hydrocushion and Motor Maintenance Points



**Figure 3: Main Bearing and Brake Maintenance Points**



**Figure 4: Hydraulic System Maintenance Points**

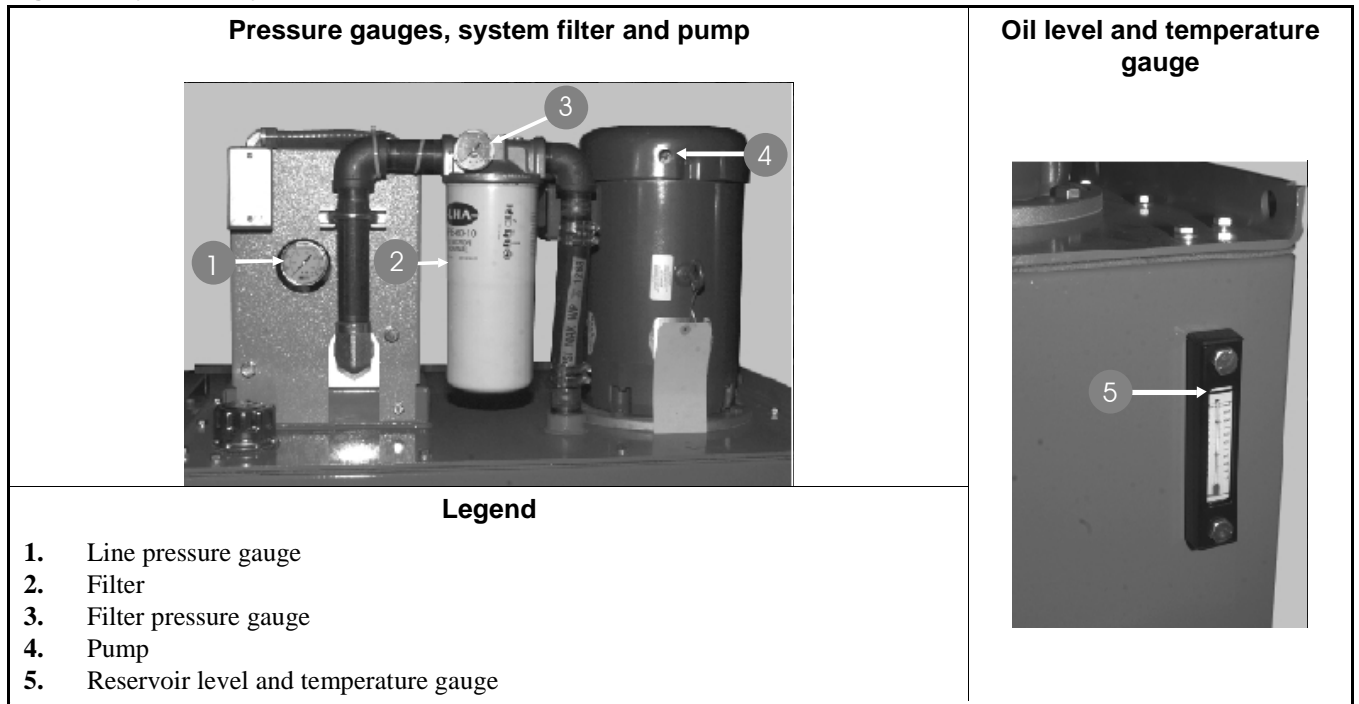


Figure 5: Reuse Water and Drain System Maintenance Points

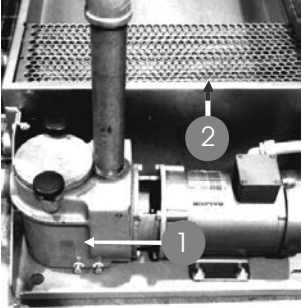
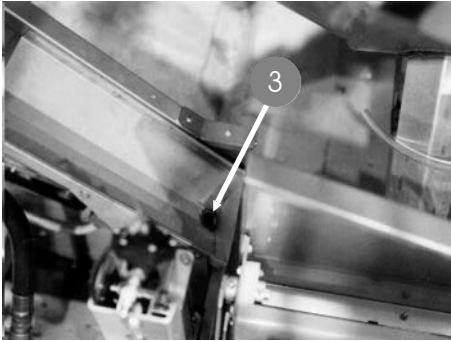

<p><b>Reuse pump and tank strainers</b></p> 	<p><b>Drip pan</b></p> 
<p><b>Load chute drain</b></p> 	<p><b>Legend</b></p> <ol style="list-style-type: none"> <li>1. Pump strainer</li> <li>2. Tank strainer</li> <li>3. Drip pan drain</li> <li>4. Load chute drain</li> </ol>

Figure 6: Conveyor Maintenance Points

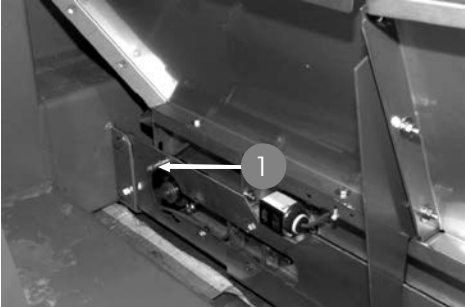

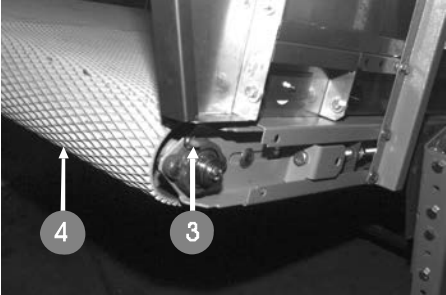
<p><b>Front roller grease point</b></p> 	<p><b>Middle roller and drive chain grease fittings</b></p> 
<p><b>Rear roller grease point (2 locations)</b></p> 	<p><b>Legend</b></p> <ol style="list-style-type: none"> <li>1. Front roller grease point (2 locations)</li> <li>2. Grease fittings for middle rollers and drive chain (2 locations)</li> <li>3. Rear roller grease point (2 locations)</li> <li>4. Belt (2 locations)</li> </ol>



Figure 7: Conveyor Drive Chain Maintenance

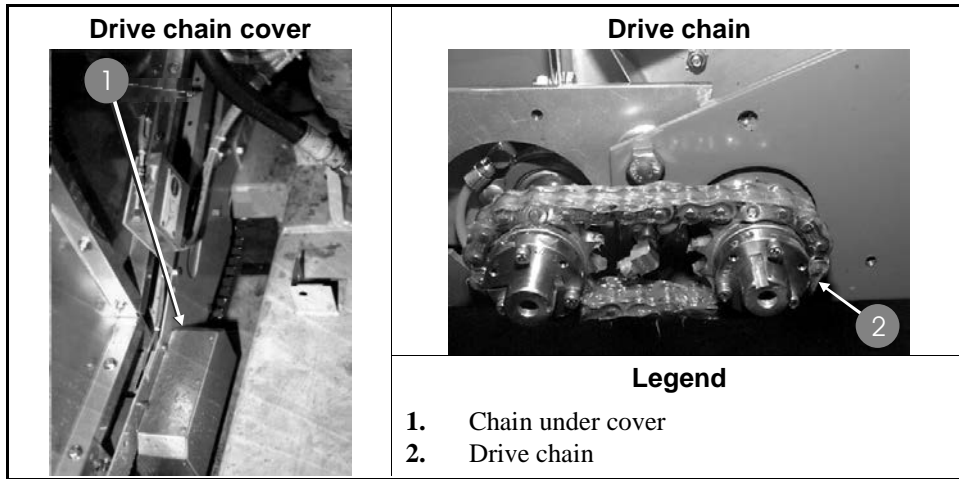
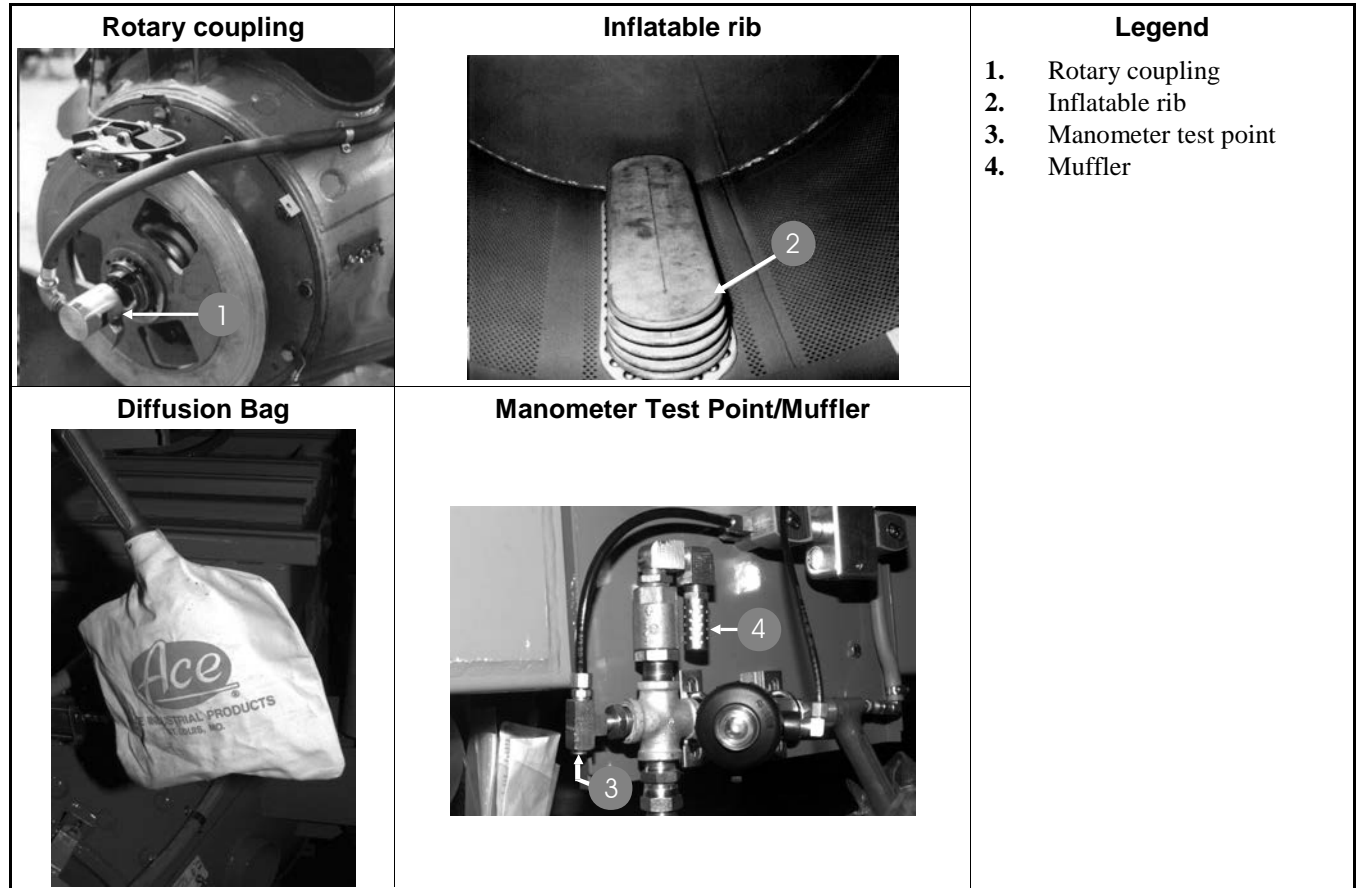


Figure 8: Optional Inflatable Rib Components



— End of BIPV7M01 —

## Motor Maintenance



This document uses Simplified Technical English.  
Learn more at <http://www.asd-ste100.org>.

This document is for motors used on Milnor<sup>®</sup> machines that have grease fittings. If the motor manufacturer supplies maintenance instructions, use them. If not, use this document.

**NOTICE P1:** "Remove power from the machine" means use the necessary safety procedure for your location. In the USA, this is the OSHA lockout/tagout (LOTO) procedure. More local requirements can also apply.



**WARNING 2: Risk of Severe Injury**—A machine in operation without safety guards can pull in and mutilate your body.

- You must be an approved maintenance technician.
- Replace guards and covers that you remove for maintenance.



**WARNING 3: Risk of Severe Injury**—The machine has electrical power when the Master switch (M) on the control panel is off or on.

- Remove power from the machine (see Notice P1).

### 1. Necessary Maintenance

- 1.1. Keep the motors clean.**—Examine and clean motors each 500 hours of operation or a minimum of each three months. Keep the motors free of dirt, oil, grease, and water. Contamination that prevents good airflow will cause too much heat and cause motor damage.
- 1.2. Examine a motor that shows unusual symptoms.** —Examine a motor that becomes too hot, makes noise, makes smoke, smells unusual, or opens the circuit breaker frequently. Examine a motor if the inverter gives errors. Make sure that all electrical connections are tight. Make sure that the wire insulation is good. Use a low resistance ohmmeter. Disassemble the motor to clean it fully If necessary.
- 1.3. Lubricate the motors.**—This document gives the lubricant frequency, quantity, type, and procedure. These are all important. See the related section in document BIIFUM02 which gives the calibration procedures for grease guns.

### 2. How to Find the Interval and Quantity of Grease to Add

**frame code**—codes for the standard motor dimensions used by motor manufacturers.

**standard interval**—the number of hours that a motor can operate in typical conditions before you must add grease.

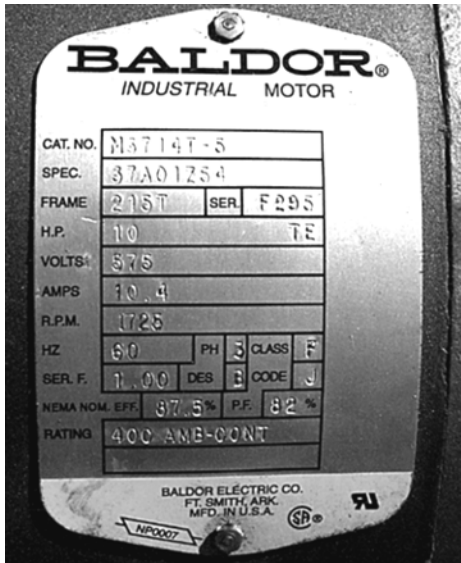
**operation conditions**—the conditions that can decrease the life of the motor and make it necessary to lubricate more frequently.

**rating**—One of three levels of operation conditions: typical, bad, very bad.

**multiplication number**—a decimal number given to the rating. Typical = 1.0, bad = 0.5, and very bad = 0.2.

This section gives the steps you use to find the interval and quantity of grease to add. The examples use the motor data plate shown in [Figure 1](#).

Figure 1: Typical Data Plate on a Motor



1. Find the frame code and RPM on the motor data plate. Example:

*Frame code = 215T, RPM = 1725*

2. Find the standard interval in [Table 1](#). Example:

*Standard interval = 12,000 hours*

3. Find the rating and multiplication number in [Table 2](#) for your worst operation condition. Example: ambient temperature = 102°F (39°C). Moderate contamination.

*Rating = bad, Multiplication number = 0.5*

4. Calculate the correct interval (the number of hours of operation before it is necessary to add grease). Example:

$$12,000 \times 0.5 = 6,000 \text{ hours}$$

Where:

12,000 is the standard interval

0.5 is the multiplication number for a rating = bad.

5. Find the quantity of grease for the frame code for your motor in [Table 3](#). You can use the bearing data in the table to do maintenance. Do not use this data to adjust the quantity of grease. Example:

*grease volume = 0.16 ounces (4.7 grams)*

*grease gun cycles = 2.5*

**Table 1: Standard Interval**

NEMA (IEC)** Range of Frame Codes	Interval in Hours for the Given RPM			
	3600 RPM*	1800 RPM*	1200 RPM*	900 RPM*
Up to 215 (132)	5500	12000	18000	22000
254 to 286 (160 - 180)	3600	9500	15000	18000
324 to 365 (200 - 225)	2200	7400	12000	15000
404 to 5000 (280 - 315) 6313 or 6314 bearings	2200	3500	7400	10500
	Roller bearings	1100	1750	3700

\* Use this column if this is near or the same RPM as your motor.  
 \*\* Frame codes given by the IEC are shown in parentheses.

**Table 2: Operation Condition and Multiplication Number**

Operation Conditions*			Rating	Multiplication Number
Maximum Ambient Temperature	Or Atmospheric Contamination	Or Bearing Type		
104°F (40°C)	Clean, not much corrosion	Ball bearing with a groove of large depth	Typical	1.0
122°F (50°C)	Moderate dirt, corrosion	Ball thrust, roller	Bad	0.5
>122°F (>50°C)	Much dirt, abrasive dust, corrosion	n.a.	Very bad	0.1

\* The worst condition sets the rating.

**Table 3: Grease Quantity (total quantity for all bearings in the motor)**

NEMA (IEC) Range of Frame Codes	Largest Bearing Dimension in Range			Quantity of Grease *		Cycles of the Grease Gun
	Category of Bearing	Outer Diameter (mm)	Width (mm)	(Ounces)	(Grams)	
0 thru 215 (132)	6307	80	21	0.16	4.7	2.5
254 to 286 (160 - 180)	6311	120	29	0.32	9.1	5
324 to 365 (200 - 225)	6313	140	33	0.43	12.2	7
404 to 5000 (280 - 315)	NU322	240	50	1.11	31.5	18

\* This is the quantity for the two bearings.

### 3. Grease Types and Procedures

Table 4: Type of Grease

Rating from Table 2	Type of Grease
Typical	Shell Dolium R, Chevron SRI, or equivalent
Bad	
Very Bad	Darmex 707 or equivalent



**CAUTION [4]: Damage and Malfunction Risks**—Too much grease gun pressure can put grease in the motor and cause electrical components to burn out. If grease touches a brake or a clutch surface, this can cause a malfunction.

- Apply grease carefully.

Apply grease as follows:

1. **Remove power from the machine (see Notice P1).**
2. Clean grease fittings.
3. If the motor has a grease outlet plug, remove it.
4. Add the recommended quantity of grease (See [Item 5](#)). Stop immediately if you see new grease around the motor shaft, wires or the grease outlet plug.
5. If the motor has a grease outlet plug, replace it.

— End of BIUUM03 —

## Torque Requirements for Fasteners



This document uses Simplified Technical English. Learn more at <http://www.asd-ste100.org>.

The document about the assembly gives the torque requirements for other fasteners. **If fastener torque specifications or threadlocker requirements in an assembly document are different from this document, use the assembly document.**

Figure 1: The Bolts in Milnor® Equipment

The Marks on Bolt Heads	Legend
	<p><b>A.</b> SAE Grades 1 and 2, ASTM A307, and stainless steel</p> <p><b>B.</b> Grade BC, ASTM A354</p> <p><b>C.</b> SAE Grade 5, ASTM A449</p> <p><b>D.</b> SAE Grade 8 and ASTM A354 BD</p>

### 1. Torque Values

These tables give the standard dimension, grade, threadlocker, and torque requirements for fasteners frequently used on Milnor® equipment.

**Note 1:** Data from the Pellerin Milnor® Corporation “Bolt Torque Specification” (bolt\_torque\_milnor.xls/2002096).

#### 1.1. Fasteners Made of Carbon Steel

##### 1.1.1. Without a Threadlocker

Table 1: Torque Values for Standard Fasteners with Maximum 5/16-inch Diameters and No Lubricant

Dimension	The Grade of the Bolt							
	Grade 2		Grade 5		Grade 8		Grade BC	
	Pound-Inches	N-m	Pound-Inches	N-m	Pound-Inches	N-m	Pound-Inches	N-m
1/4 x 20	66	7	101	11	143	16	126	14
1/4 x 28	76	9	116	13	163	18	--	--
5/16 x 18	136	15	209	24	295	33	258	29
5/16 x 24	150	17	232	26	325	37	--	--

Torque Requirements for Fasteners

**Table 2: Torque Values for Standard Fasteners Larger Than 5/16-inch Diameters and No Lubricant**

Dimension	The Grade of the Bolt							
	Grade 2		Grade 5		Grade 8		Grade BC	
	Pound-feet	N-m	Pound-feet	N-m	Pound-feet	N-m	Pound-feet	N-m
3/8 x 16	20	27	31	42	44	59	38	52
3/8 x 24	23	31	35	47	50	68	--	--
7/16 x 14	32	43	49	66	70	95	61	83
7/16 x 20	36	49	55	75	78	105	--	--
1/2 x 13	49	66	75	102	107	145	93	126
1/2 x 20	55	75	85	115	120	163	--	--
9/16 x 12	70	95	109	148	154	209	134	182
9/16 x 18	78	106	121	164	171	232	--	--
5/8 x 11	97	131	150	203	212	287	186	252
5/8 x 18	110	149	170	231	240	325	--	--
3/4 x 10	172	233	266	361	376	510	329	446
3/4 x 16	192	261	297	403	420	569	--	--
7/8 x 9	167	226	429	582	606	821	531	719
7/8 x 14	184	249	473	641	668	906	--	--
1 x 8	250	339	644	873	909	1232	796	1079
1 x 12	274	371	704	954	994	1348	--	--
1 x 14	281	381	723	980	1020	1383	--	--
1 1/8 x 7	354	480	794	1077	1287	1745	1126	1527
1 1/8 x 12	397	538	891	1208	1444	1958	--	--
1 1/4 x 7	500	678	1120	1519	1817	2464	1590	2155
1 1/4 x 12	553	750	1241	1682	2012	2728	--	--
1 3/8 x 6	655	888	1469	1992	2382	3230	2085	2827
1 3/8 x 12	746	1011	1672	2267	2712	3677	--	--
1 1/2 x 6	869	1178	1949	2642	3161	4286	2767	3751
1 1/2 x 12	979	1327	2194	2974	3557	4822	--	--

**Table 3: Torque Values for Plated Fasteners with Maximum 5/16-inch Diameters and No Lubricant**

Dimension	The Grade of the Bolt							
	Grade 2		Grade 5		Grade 8		Grade BC	
	Pound-Inches	N-m	Pound-Inches	N-m	Pound-Inches	N-m	Pound-Inches	N-m
1/4 x 20	49	6	76	9	107	12	95	11
1/4 x 28	56	6	88	10	122	14	--	--
5/16 x 18	102	12	156	18	222	25	193	22
5/16 x 24	113	13	174	20	245	28	--	--

**Table 4: Torque Values for Plated Fasteners Larger Than 5/16-inch Diameters and No Lubricant**

Dimension	The Grade of the Bolt							
	Grade 2		Grade 5		Grade 8		Grade BC	
	Pound-feet	N-m	Pound-feet	N-m	Pound-feet	N-m	Pound-feet	N-m
3/8 x 16	15	20	23	31	33	44	29	38
3/8 x 24	17	23	26	35	37	49	--	--
7/16 x 14	24	32	37	50	52	71	46	61
7/16 x 20	27	36	41	55	58	78	--	--
1/2 x 13	37	49	56	76	80	106	70	93
1/2 x 20	41	55	64	85	90	120	--	--
9/16 x 12	53	70	81	110	115	153	101	134
9/16 x 18	59	79	91	122	128	174	--	--
5/8 x 11	73	97	113	150	159	212	139	186
5/8 x 18	83	110	127	172	180	240	--	--
3/4 x 10	129	173	200	266	282	376	246	329
3/4 x 16	144	192	223	297	315	420	--	--
7/8 x 9	125	166	322	430	455	606	398	531
7/8 x 14	138	184	355	474	501	668	--	--
1 x 8	188	250	483	644	682	909	597	796
1 x 12	205	274	528	716	746	995	--	--
1 x 14	210	280	542	735	765	1037	--	--
1 1/8 x 7	266	354	595	807	966	1288	845	1126
1 1/8 x 12	298	404	668	890	1083	1444	--	--
1 1/4 x 7	375	500	840	1120	1363	1817	1192	1590
1 1/4 x 12	415	553	930	1261	1509	2013	--	--
1 3/8 x 6	491	655	1102	1470	1787	2382	1564	2085
1 3/8 x 12	559	758	1254	1672	2034	2712	--	--
1 1/2 x 6	652	870	1462	1982	2371	3161	2075	2767
1 1/2 x 12	733	994	1645	2194	2668	3557	--	--

## 1.1.2. With a Threadlocker

**Table 5: Threadlocker by the Diameter of the Bolt (see Note 2)**

LocTite Product	Dimension			
	1/4-inch	1/4- to 5/8-inch	5/8- to 7/8-inch	1-inch +
LocTite 222	OK			
LocTite 242		OK		
LocTite 262			OK	
LocTite 272			High temperature	
LocTite 277				OK

**Note 2:** The acceptable bolt size ranges for various LocTite® threadlocking products is the LocTite manufacturer's **general** recommendation. Specific applications sometime require that a LocTite product is applied to a bolt size outside the ranges shown here. For example, Milnor specifies LocTite 242 for use on certain 1" bolt applications and has confirmed this usage with the LocTite manufacturer. You may see variances such as this in the documentation for specific machine assemblies.



Torque Requirements for Fasteners

**Table 6: Torque Values if You Apply LocTite 222**

Dimension	The Grade of the Bolt							
	Grade 2		Grade 5		Grade 8		Grade BC	
	Pound-inches	N-m	Pound-inches	N-m	Pound-inches	N-m	Pound-inches	N-m
1/4 x 20	60	7	96	11	132	15	108	12
1/4 x 28	72	8	108	12	144	16	--	--

**Table 7: Torque Values if You Apply LocTite 242**

Dimension	The Grade of the Bolt							
	Grade 2		Grade 5		Grade 8		Grade BC	
	Pound-feet	N-m	Pound-feet	N-m	Pound-feet	N-m	Pound-feet	N-m
5/16 x 18	11	15	17	23	25	34	22	30
5/16 x 24	13	18	19	26	27	37	27	37
3/8 x 16	20	27	31	42	44	60	38	52
3/8 x 24	23	31	35	47	50	68	--	--
7/16 x 14	32	43	49	66	70	95	61	83
7/16 x 20	36	49	55	75	78	106	--	--
1/2 x 13	49	66	75	102	107	145	93	126
1/2 x 20	55	75	85	115	120	163	--	--
9/16 x 12	70	95	109	148	154	209	134	182
9/16 x 18	78	106	121	164	171	232	--	--
5/8 x 11	97	132	150	203	212	287	186	252
5/8 x 18	110	149	170	230	240	325	--	--

**Table 8: Torque Values if You Apply LocTite 262**

Dimension	The Grade of the Bolt							
	Grade 2		Grade 5		Grade 8		Grade BC	
	Pound-feet	N-m	Pound-feet	N-m	Pound-feet	N-m	Pound-feet	N-m
3/4 x 10	155	210	240	325	338	458	296	401
3/4 x 16	173	235	267	362	378	512	--	--
7/8 x 9	150	203	386	523	546	740	477	647
7/8 x 14	165	224	426	578	601	815	--	--

**Table 9: Torque Values if You Apply LocTite 272 (High-Temperature)**

Dimension	The Grade of the Bolt							
	Grade 2		Grade 5		Grade 8		Grade BC	
	Pound-feet	N-m	Pound-feet	N-m	Pound-feet	N-m	Pound-feet	N-m
<b>1 x 8</b>	350	475	901	1222	1272	1725	1114	1510
<b>1 x 12</b>	383	519	986	1337	1392	1887	--	--
<b>1 x 14</b>	393	533	1012	1372	1428	1936	--	--
<b>1-1/8 x 7</b>	496	672	1111	1506	1802	2443	1577	2138
<b>1-1/8 x 12</b>	556	754	1247	1691	2022	2741	--	--
<b>1-1/4 x 7</b>	700	949	1568	2126	2544	3449	2226	3018
<b>1-1/4 x 12</b>	774	1049	1737	2355	2816	3818	--	--
<b>1-3/8 x 6</b>	917	1243	2056	2788	3335	4522	2919	3958
<b>1-3/8 x 12</b>	1044	1415	2341	3174	3797	5148	--	--
<b>1-1/2 x 6</b>	1217	1650	2729	3700	4426	6001	3873	5251
<b>1-1/2 x 12</b>	1369	1856	3071	4164	4980	6752	--	--

**Table 10: Torque Values if You Apply LocTite 277**

Dimension	The Grade of the Bolt							
	Grade 2		Grade 5		Grade 8		Grade BC	
	Pound-feet	N-m	Pound-feet	N-m	Pound-feet	N-m	Pound-feet	N-m
<b>1 x 8</b>	325	441	837	1135	1181	1601	1034	1402
<b>1 x 12</b>	356	483	916	1242	1293	1753	--	--
<b>1 x 14</b>	365	495	939	1273	1326	1798	--	--
<b>1-1/8 x 7</b>	461	625	1032	1399	1674	2270	1464	1985
<b>1-1/8 x 12</b>	516	700	1158	1570	1877	2545	--	--
<b>1-1/4 x 7</b>	650	881	1456	1974	2362	3202	2067	2802
<b>1-1/4 x 12</b>	719	975	1613	2187	2615	3545	--	--
<b>1-3/8 x 6</b>	851	1154	1909	2588	3097	4199	2710	3674
<b>1-3/8 x 12</b>	970	1315	2174	2948	3526	4781	--	--
<b>1-1/2 x 6</b>	1130	1532	2534	3436	4110	5572	3597	4877
<b>1-1/2 x 12</b>	1271	1723	2852	3867	4624	6269	--	--

## 1.2. Stainless Steel Fasteners

**Table 11: Torque Values for Stainless Steel Fasteners 5/16-inch and Smaller**

Dimension	316 Stainless		18-8 Stainless		18-8 Stainless with Loctite 767	
	Pound-Inches	N-m	Pound-Inches	N-m	Pound-Inches	N-m
<b>1/4 x 20</b>	79	9	76	9	45	5
<b>1/4 x 28</b>	100	11	94	11	56	6
<b>5/16 x 18</b>	138	16	132	15	79	9
<b>5/16 x 24</b>	148	17	142	16	85	10

**Table 12: Torque Values for Stainless Steel Fasteners Larger Than 5/16-inch**

Dimension	316 Stainless		18-8 Stainless		18-8 Stainless with Loctite 767	
	Pound-feet	N-m	Pound-feet	N-m	Pound-feet	N-m
3/8 x 16	21	28	20	27	12	16
3/8 x 24	23	31	22	29	13	18
7/16 x 14	33	44	31	42	19	25
7/16 x 20	35	47	33	45	20	27
1/2 x 13	45	61	43	58	26	35
1/2 x 20	47	64	45	61	27	37
9/16 x 12	59	81	57	77	34	46
9/16 x 18	66	89	63	85	38	51
5/8 x 11	97	131	93	125	56	75
5/8 x 18	108	150	104	141	62	84
3/4 x 10	132	179	128	173	77	104
3/4 x 16	130	176	124	168	75	101
7/8 x 9	203	275	194	263	116	158
7/8 x 14	202	273	193	262	116	157
1 x 8	300	406	287	389	172	233
1 x 14	271	367	259	351	156	211
1-1/8 x 7	432	586	413	560	248	336
1-1/8 x 12	408	553	390	529	234	317
1-1/4 x 7	546	740	523	709	314	425
1-1/4 x 12	504	683	480	651	288	390
1-1/2 x 6	930	1261	888	1204	533	722
1-1/2 x 12	732	992	703	953	422	572

## 2. Preparation



**WARNING 2: Fire Hazard**—Some solvents and primers are flammable.

- Use threadlocker and primers with sufficient airflow.
  - Do not use flammable material near ignition sources.
1. Clean all threads with a wire brush or a different tool.
  2. Remove the grease from the fasteners and the mating threads with solvent. Make the parts dry.

**Note 3:** Loctite 7649 Primer™ or standard solvents will remove grease from parts.

3. Apply a spray of Loctite 7649 Primer™ or equal on the fasteners and the mating threads. Let the primer dry for one minute minimum.

## 3. How to Apply a Threadlocker

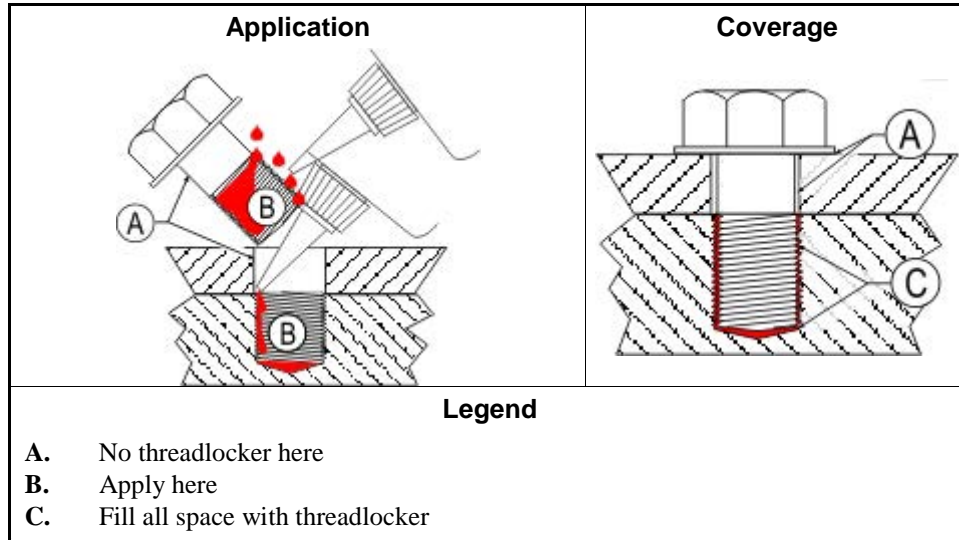


**CAUTION 3: Malfunction Hazard**—Heat, vibration, or mechanical shocks can let the fasteners loosen if you do not apply the threadlocker correctly. Loose fasteners can cause malfunctions of the equipment.

- Read the threadlocker manufacturer's instructions and warnings. Obey these instructions.

Apply the threadlocker only to the areas where the fastener threads and the mating threads engage.

**Figure 2: Blind Hole**



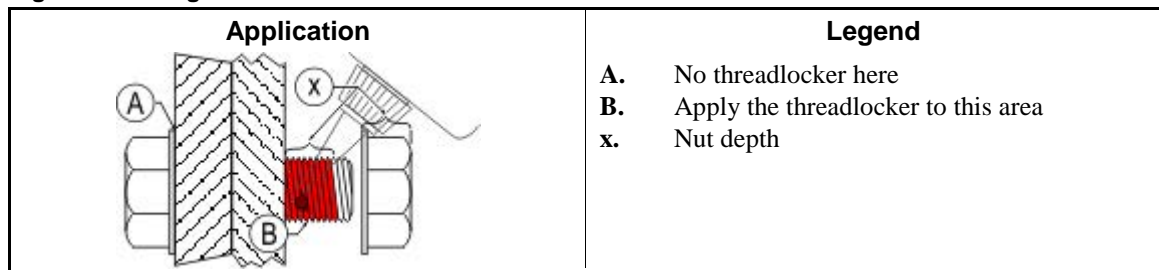
### 3.1. Blind Holes

1. Apply the threadlocker down the threads to the bottom of the hole.
2. Apply the threadlocker to the bolt.
3. Tighten the bolt to the value shown in the correct table ([Table 5](#) to [Table 11](#)).

### 3.2. Through Holes

1. Put the bolt through the assembly.
2. Apply the threadlocker only to the bolt thread area that will engage the nut.
3. Tighten the bolt to the value shown in the correct table ([Table 5](#) to [Table 11](#)).

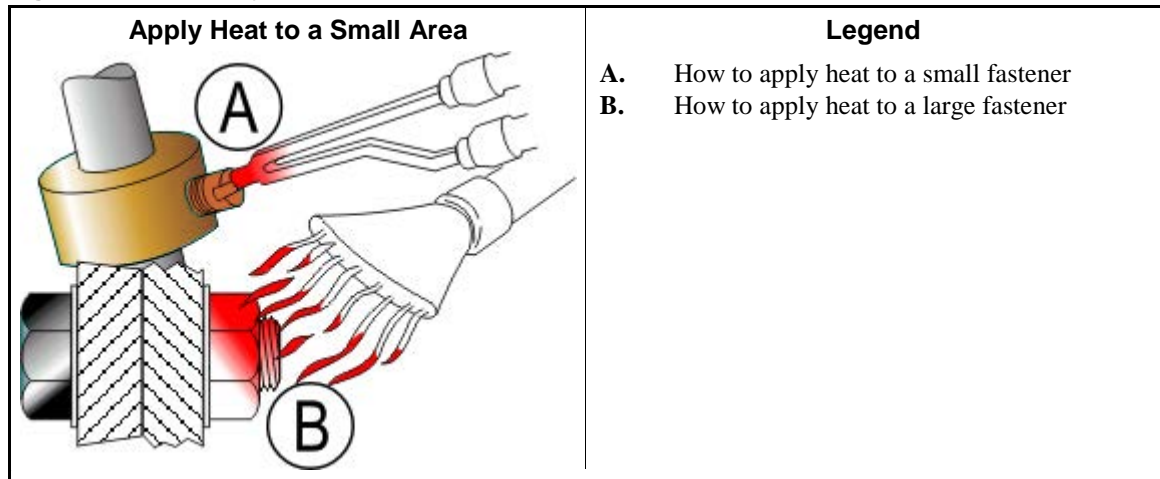
**Figure 3: Through Hole**



- 3.3. Disassembly**—For high-strength threadlocker, apply heat for five minutes. Disassemble with hand tools while the parts are hot.

For low-strength and moderate-strength threadlocker, disassemble with hand tools.

Figure 4: Disassembly



— End of BIUUM04 —

# Conveyor Lubrication & Chain Adjustments

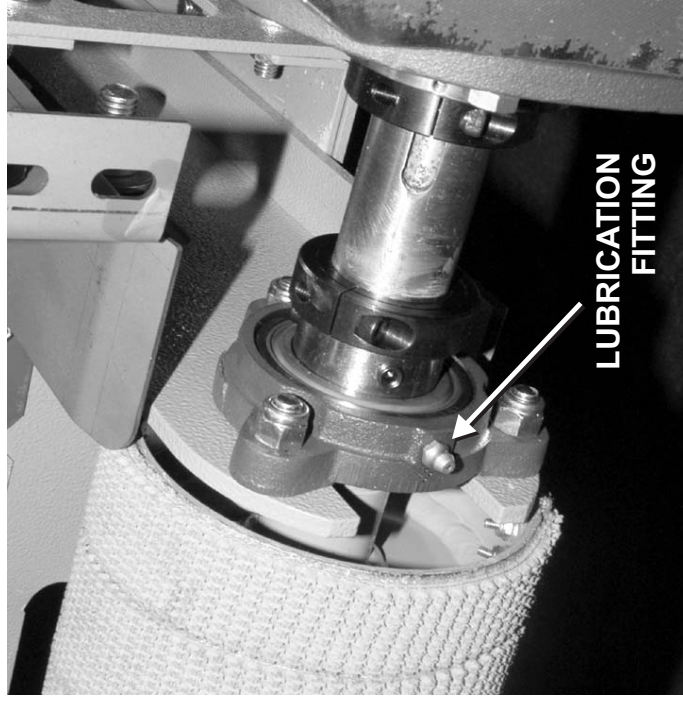
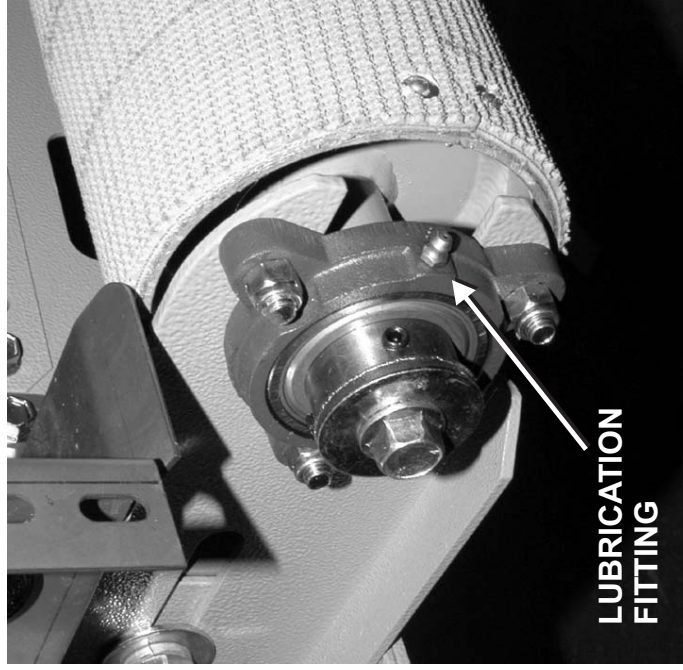
## Flatbelt, Load Conveyors & Extractor Conveyors

BMP070001/2007042A  
(Sheet 1 of 2)

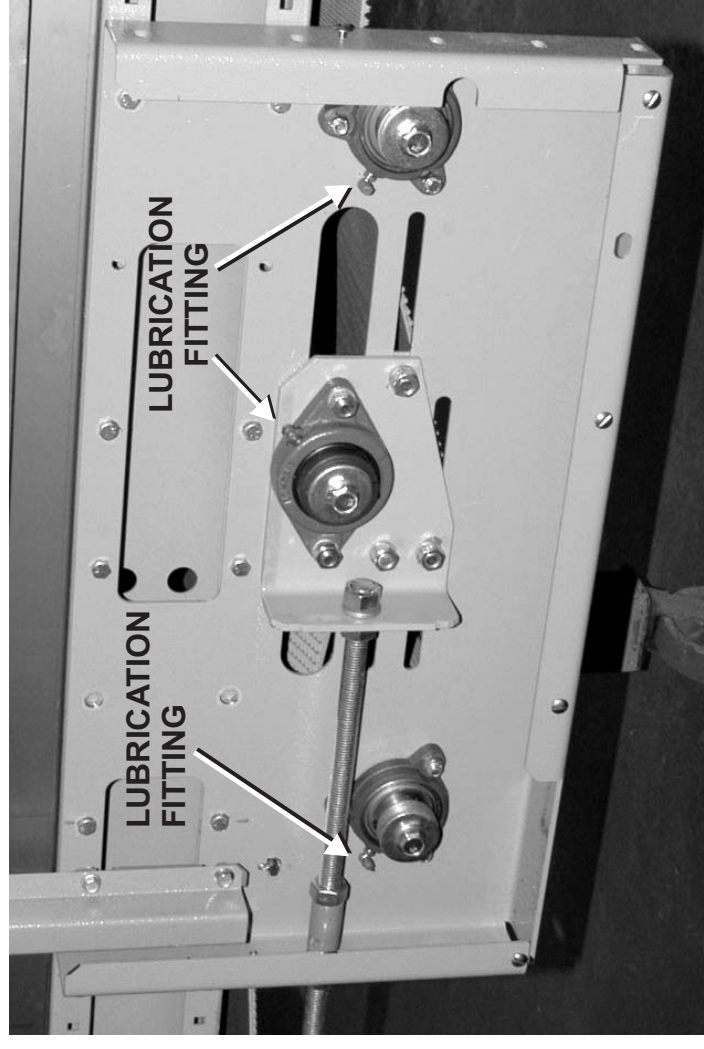


**Pellerin Milnor Corporation**  
P. O. Box 400, Kenner, LA 70063-0400

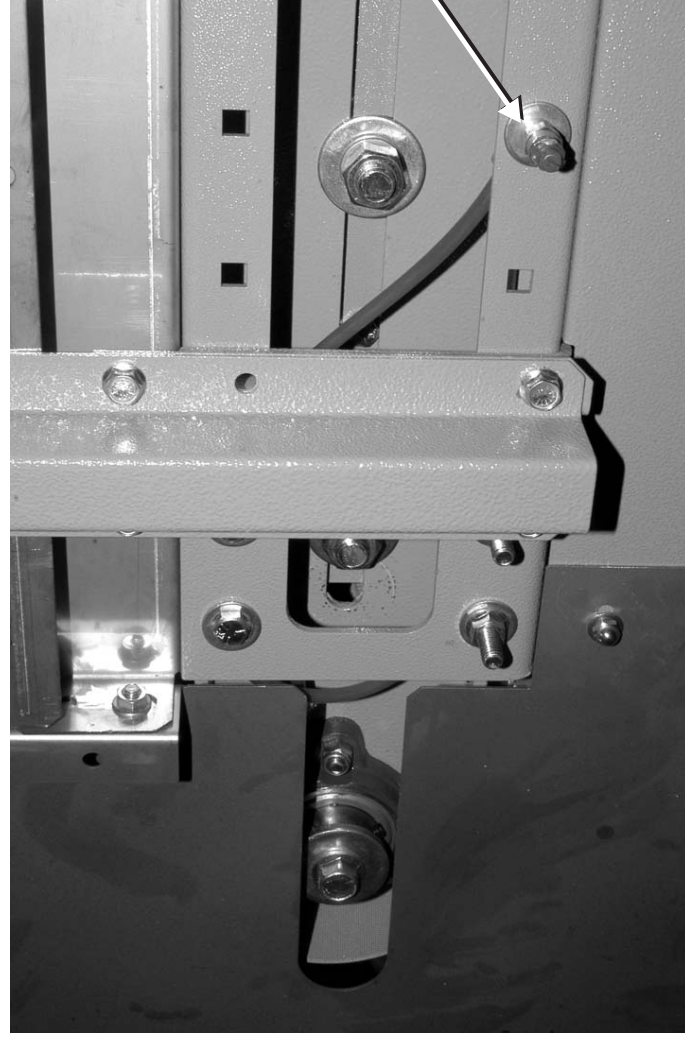
Litho in U.S.A.



**TYPICAL: FLATBELT CONVEYORS**



**TYPICAL: UNDERDRIVE**



**TYPICAL: LOAD CONVEYORS**

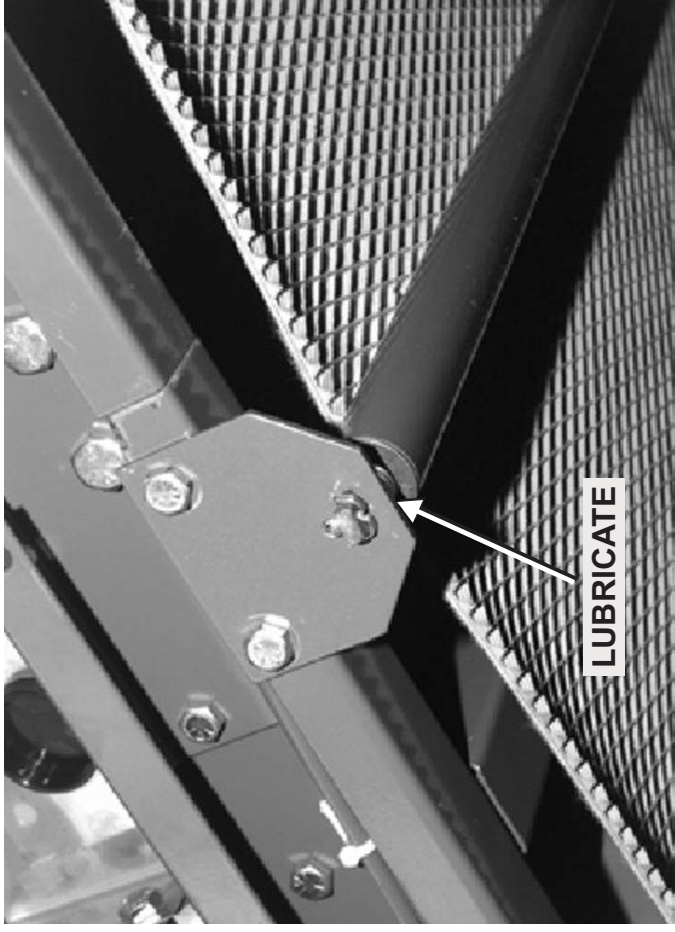
### CONVEYOR LUBRICATION:

Every three months, all CONVEYOR ROLLER BEARINGS should be lubricated with bearing lubricant, Shell Alvania EP2 Lithium Grease or equivalent, using a hand pressure grease gun. Lubrication fittings are located on the bearings when they are easily accessible or they are remotely located to a position on the conveyor bed frame, if the bearing cannot be reached easily.



Pellerin Milnor Corporation  
 P. O. Box 400, Kenner, LA 70063-0400

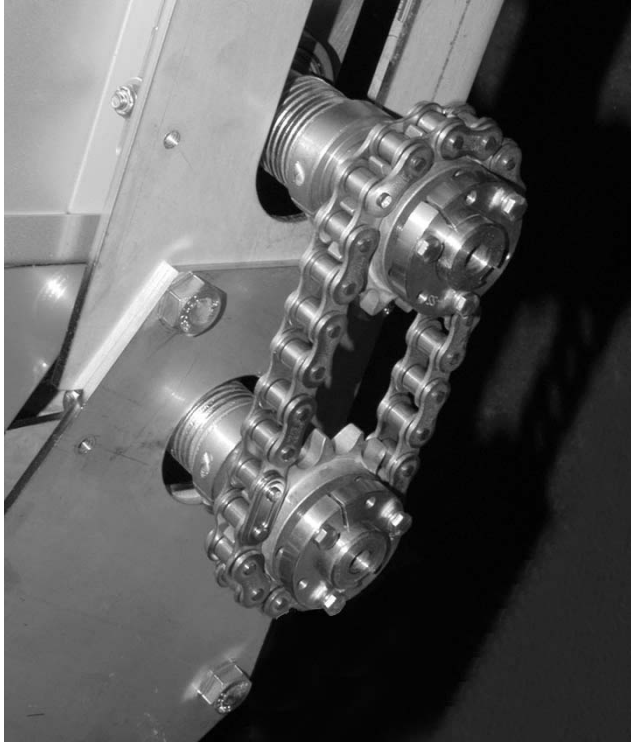
Litho in U.S.A.



TYPICAL: IDLER ROLLER

**CHAIN LUBRICATION:**

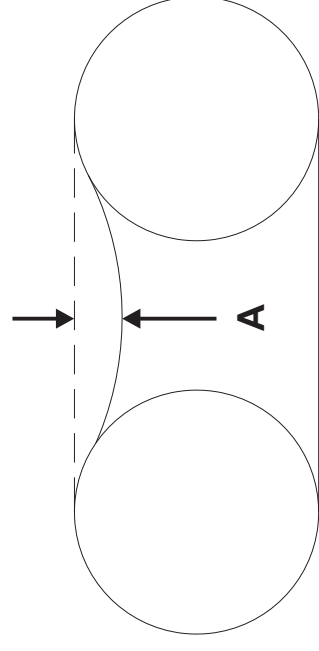
Every thirty days of operation, **CHAIN DRIVES** should be lubricated with bearing lubricant, Shell Alvania EP2 Lithium Grease or equivalent. Chain drives are covered by a safety cover and their lubrication fitting are remotely mounted where they are easily accessible.



**CHAIN ADJUSTMENTS:**

Every thirty days of operation, **CHAIN DRIVES** should be checked for proper adjustment.

A = 0 - .125" [0- 3mm]      New Chain  
 A= .125" - .25" [3mm - 6mm]      After 48 hours



# Conveyor Adjustment Procedures Flatbelt & Load Conveyors

BMP820015/96322V  
(Sheet 1 of 3)



Pellerin Milnor Corporation  
P. O. Box 400, Kenner, LA 70063-0400

BMP820015/96322V (1 of 3)

Litho in U.S.A.

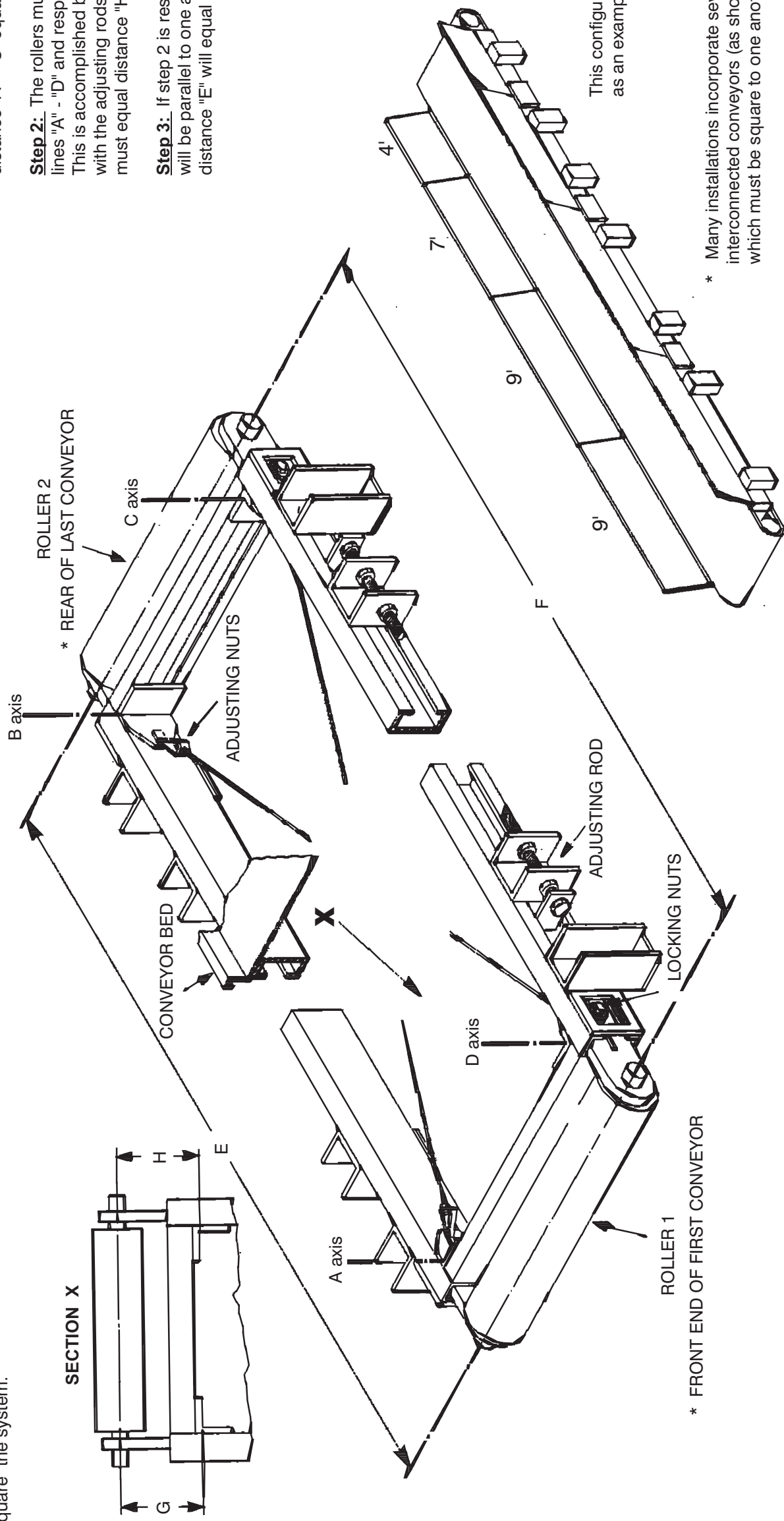
### Comments:

To provide optimum durability of the conveyor belt, it is essential that the conveyor is properly "squared". These instructions define the procedures to "square" the system.

**Step 1:** The conveyor frame must be "square". This is accomplished by adjusting the tie rods between points "A" - "C" and "B" - "D". The frame is "square" if and only if met: distance "A" - "C" equals distance "B" - "D".

**Step 2:** The rollers must be parallel to the lines "A" - "D" and respectively "B" - "C". This is accomplished by moving the rollers with the adjusting rods. Therefore distance "G" must equal distance "H".

**Step 3:** If step 2 is respected the rollers will be parallel to one another, therefore distance "E" will equal distance "F".



This configuration is shown as an example only.

\* Many installations incorporate several interconnected conveyors (as shown above) which must be square to one another.



# Conveyor Adjustment Procedures

## Flatbelt & Load Conveyors

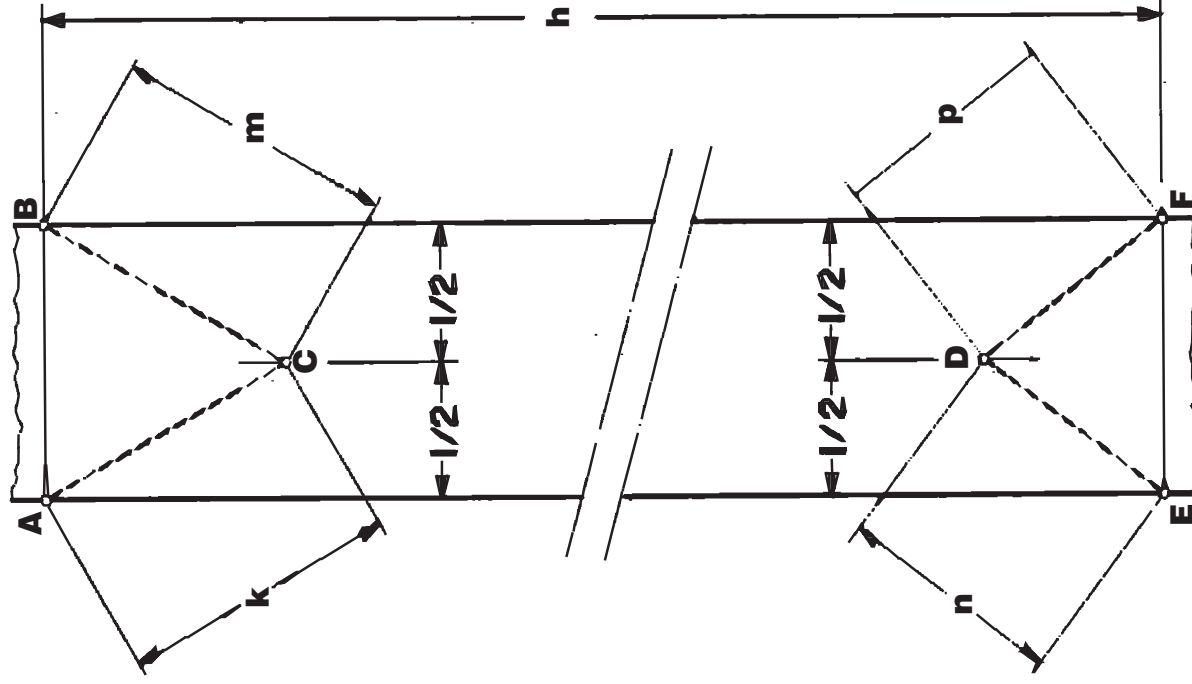
BMP820015/96322V  
(Sheet 2 of 3)



Pellerin Milnor Corporation  
P. O. Box 400, Kenner, LA 70063-0400

BMP820015/96322V (2 of 3)

Litho in U.S.A.



**Step 1:** At some point well back from the end of the belt, measure and carefully mark a point (C) at the exact center of the belt width.

**Step 2:** Measure from this centerpoint two equal lengths (k and m) and mark points (A and B) along the edges and near the end of the belt. Be sure length "k" equals length "m".

**Step 3:** Measure the total desired length (h) from point "B" to point "F" and mark that point.

**Step 4:** At some point well back from this end of the belt, mark a point (D) at the exact center of the belt width.

**Step 5:** Repeat step 2 to find point "E". Be sure that length "n" equals length "p".

**Step 6:** Cut along lines "A" - "B" and "E" - "F". Cuts must be straight so that the ends may be laced together without causing the belt material to warp.

(THIS PROCEDURE TO BE USED IF A BELT IS TO BE CUT AND LACED IN THE FIELD.)

# Conveyor Adjustment Procedures Flatbelt & Load Conveyors

BMP820015/96322V  
(Sheet 3 of 3)



Pellerin Milnor Corporation  
P. O. Box 400, Kenner, LA 70063-0400

BMP820015/96322V (3 of 3)

Litho in U.S.A.

**Step 1:** Check the conveyor frame to make sure it is square in accordance with illustration 1. Make sure the ends of the belt are square and laced properly in accordance with illustration 2.

**Step 2:** Run the conveyor for enough revolutions to indicate what direction it tracks.

Example: If the belt tracks to the right, adjust the right side non driven end adjusting rod (for double ended drives pick one end to adjust only) by following these steps:

**Step 2a:** Loosen the two (2) 5/8" drive locking nuts.

**Step 2b:** Turn the adjusting rod so as to move the right side non-driven end out until the belt is tracking straight.

**Step 2c:** Retighten the locking nuts.

**Step 2d:** If the above procedure does not correct the problem apply the same steps on the right side driven end.

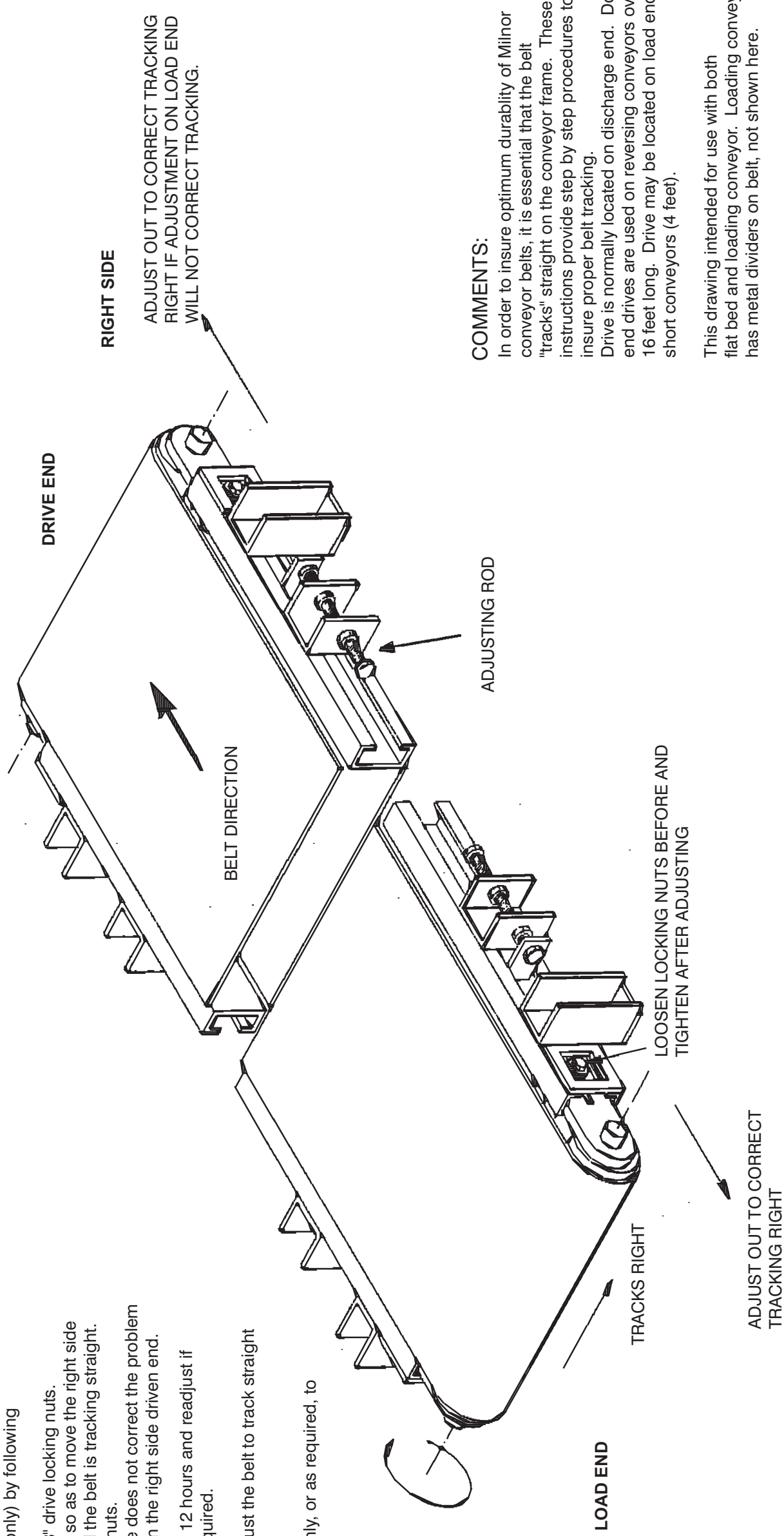
**Step 3:** Run the conveyor for at least 12 hours and readjust if necessary. Frequent inspection is required.

**Step 4:** After 72 hours operating, adjust the belt to track straight if required.

**Step 5:** Check the belt at least monthly, or as required, to insure straight tracking.

**WARNING:**

When moving conveyor, never allow frame to twist; such as would occur if one corner were raised higher than the others. Misalignment and damage to the frame may occur.



**COMMENTS:**

In order to insure optimum durability of Milnor conveyor belts, it is essential that the belt "tracks" straight on the conveyor frame. These instructions provide step by step procedures to insure proper belt tracking.  
Drive is normally located on discharge end. Double end drives are used on reversing conveyors over 16 feet long. Drive may be located on load end of short conveyors (4 feet).

This drawing intended for use with both flat bed and loading conveyor. Loading conveyor has metal dividers on belt, not shown here.

---

---

## INSTALLING ANTI-FRICTION STRIPS

---

**APPLICABILITY:** Flatbed conveyors

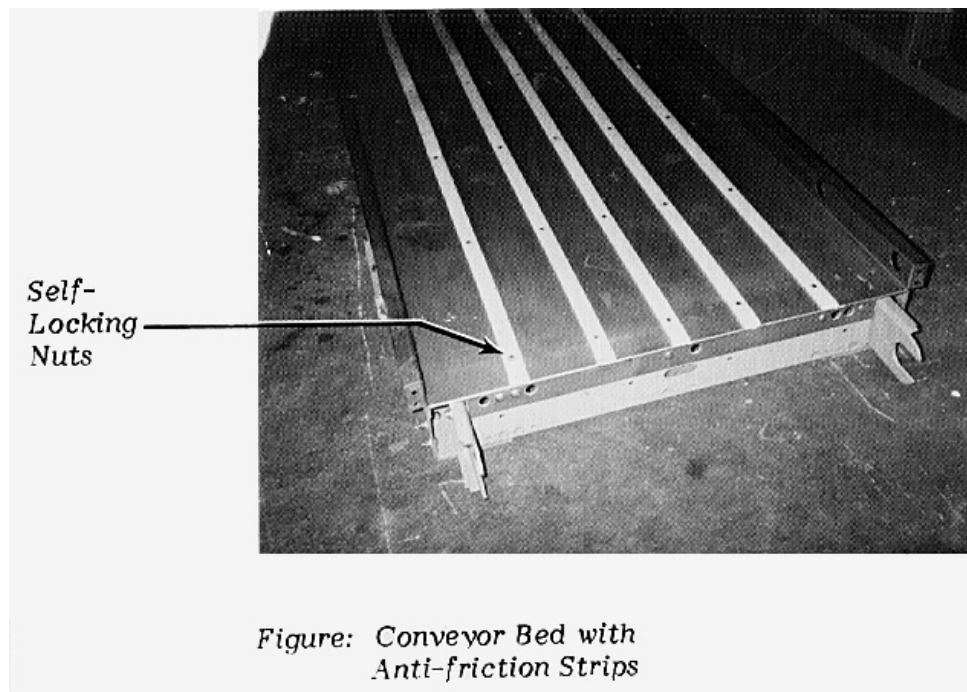
---

**SCOPE:** Purpose for; how to install strips

---

The polymer anti-friction strips shipped with your conveyor must be installed after the conveyor sections have been joined together. These strips which run continuous along the entire conveyor length, prevent the conveyor belt from adhering to the bed and straining the motor when the conveyor is started.

Once all conveyor sections have been joined and before installing the belt, attach these strips as shown in the figure below using the flat head bolts and self locking nuts provided. Note that the holes in both the strips and the conveyor bed were pre-drilled.



---

---

# INCLINED STORAGE CONVEYOR ASSEMBLY INSTRUCTIONS

---

**APPLICABILITY:** Inclined Storage Conveyor

---

---

**SCOPE:** How to assemble

---

**NOTE:** Storage conveyors are generally shipped fully assembled or in various stages of assembly depending on special site conditions.

## General

It is recommended to assemble inclined COSTO conveyors in the following sequence:

1. Join beds.
2. Install plastic anti-friction strips.
3. Install adjustment leg mounts.
4. Install belt to conveyor bed.
5. Install load end legs.
6. Install unloading end legs.
7. Install middle legs.
8. Install cross members.
9. Anchor bolt legs to floor where applicable.
10. Mount motor to gear reducer where applicable.
11. Make electrical connection and extend safety shut-off switch wires.

## Installation Procedure

### Joining Beds

Each conveyor bed is comprised of one or more 4, 7, or 9 foot section.

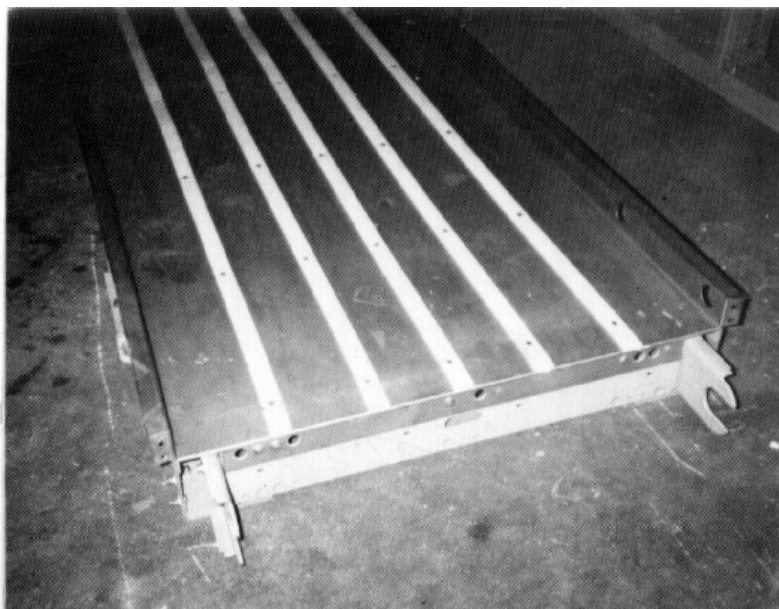
The connection between bed sections is made by eight 3/8" carriage bolts at each corner of the middle section or junction of two beds. (Combination: nut, bolt, lockwasher, and flatwasher.) Six on the side and two underneath.

When bolting sections together make sure all butting surfaces are flush and the conveyor is level along the entire length. Refer to BMP820024 for flat bed conveyor assembly details.

## **Install Plastic Anti-Friction Strips**

The polymer anti-friction strips shipped with your conveyor must be installed after the conveyor sections have been joined together. These strips which run continuously along the entire conveyor length, prevent the conveyor belt from adhering to the bed and straining the motor when the conveyor is started.

Attach anti-friction strips as shown in the figure next page using the flat head bolts and self-locking nuts supplied. Note that the strips and conveyor bed were pre-drilled. Bolt heads must be countersunk slightly below the top surface of the strip to assure that bolt head doesn't cut into belt material.

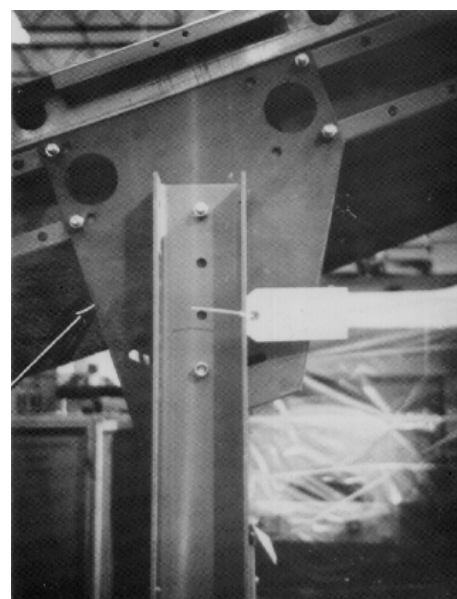


*FIGURE 1: Install Anti-Friction Strips*

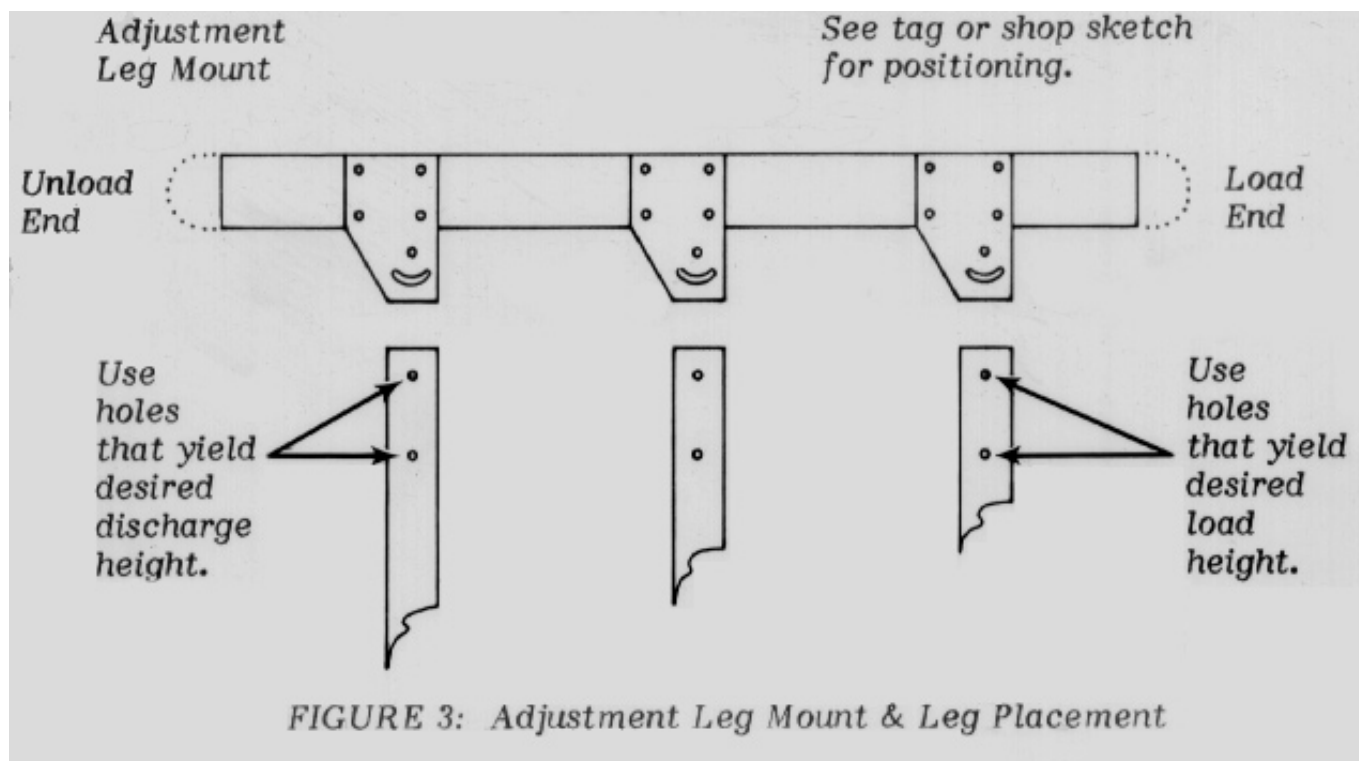
## **Install Adjustment Leg Mounts**

In order to raise conveyor from resting on floor, it is recommended to mount the adjustment leg mounts to the sides of the conveyor. Adjustment leg mount locations are marked with tags or illustrated by a shop sketch for positioning. Mounts are bolted to the conveyor bed in four places, as shown in the photo right, and figure next page.

**Note:** All bolts for attaching leg adjustment mounts, legs, and cross members are 1/2". All nuts have full threads and are used in a combination of bolt, lock-washer, and nut. Flatwashers are added where slotted holes are being used.



*FIGURE 2: Adjustment Leg Mount*



### **Install Belt**

Belt tension adjustments are made on the idler (load) end. The bearing carrier is attached loosely to adjust tension after belt is on. See BMP820024 for more information.

### **Install Load End Legs**

Raise load end of conveyor to load height. Position legs on adjustment leg mounts (see illustration above) and secure loosely.

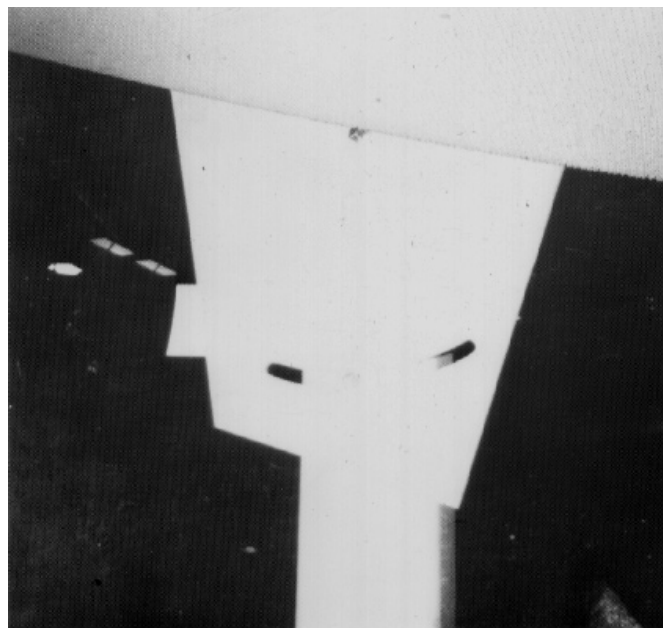
### **Install Unloading End Legs**

Raise unloading end of conveyor to discharge height and secure legs to adjustment leg mounts.

**CAUTION:** Do not lift conveyor from roller. This may damage the roller or belt. Lift from connecting bracket or conveyor bed. See BMP820024.

### **Install Middle Legs**

Install middle legs to adjustment leg mount and secure. Go back and adjust all legs vertically and tighten all bolts.



**FIGURE 4: Backview Leg Connection**

### **Install Crossmembers**

Cross members are used in pairs, bracing legs front and back. Shorter legs ranging from 9" to 26" do not require crossmembers, whereas legs ranging from 27" to 145" require cross-bracing approximately 13" from the bottom of the leg using pre-drilled holes. Taller legs, ranging from 40" to 145" require a second pair of cross braces placed near the top of the legs where bolt holes are available. (See photo right.)

### **Anchor to Foundation**

Use one 1" 0 anchor bolt per leg. Anchor bolt hardware not supplied by Pellerin Milnor Corporation.

### **Mount Motors**

All conveyors are shipped with gear reducers mounted to the drive roller (unloading end). Motors may need to be mounted to the gear reducer if shipped detached.

**Note:** No adjustment is needed on the drive end of the system.

### **Additional Connections**

Make electrical connection and extend safety shut-off switch wires.



FIGURE 5: Crossmembers, one of two shown.





# Shell and Door Assemblies

2

**Shell Assembly**

**M7E4232C,L,R M9E4232C,L,R M7V4232C,L,R M9V4232C,L,R**

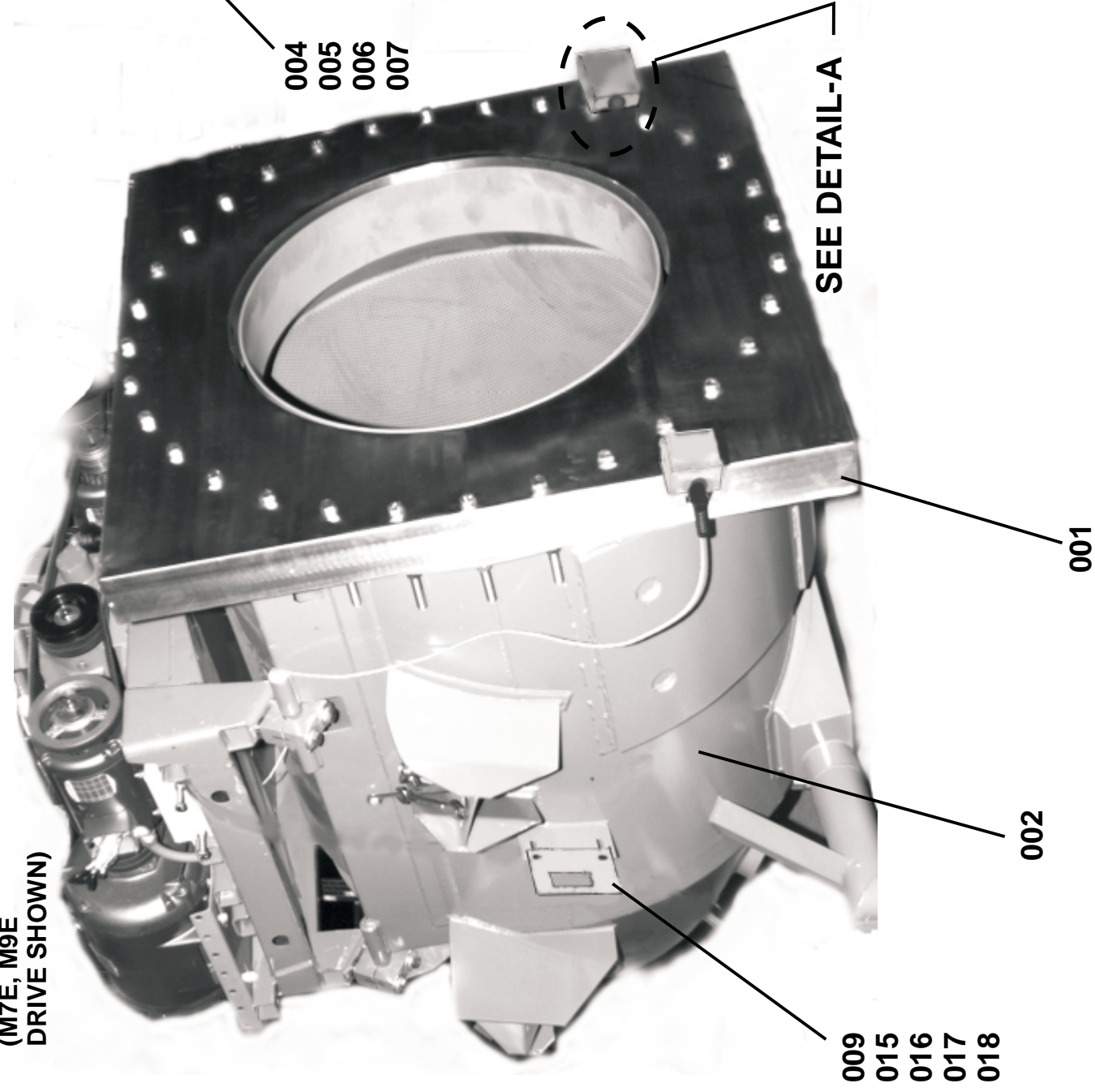
BMP940020/2001204V  
(Sheet 1 of 2)



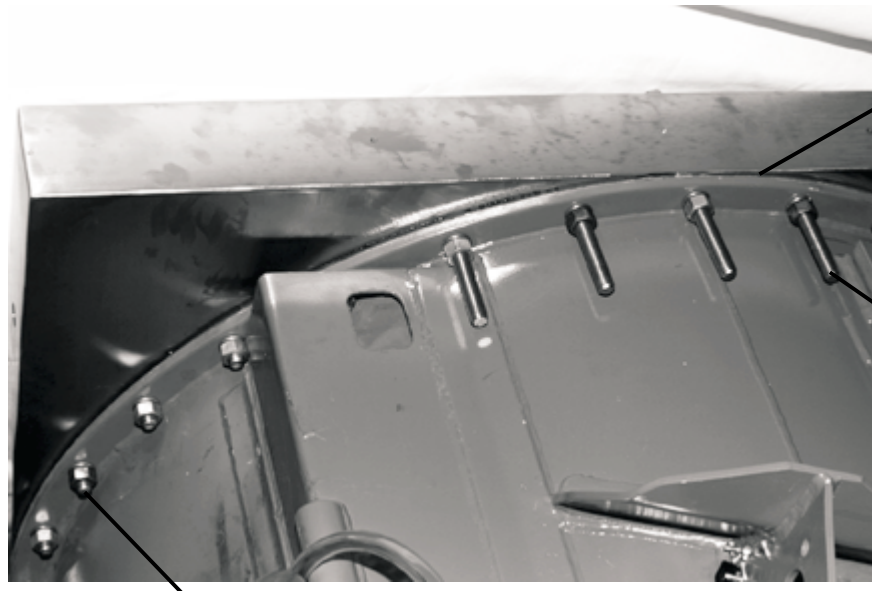
Pellerin Milnor Corporation  
P. O. Box 400, Kenner, LA 70063-0400

Litho in U.S.A.

(M7E, M9E  
DRIVE SHOWN)

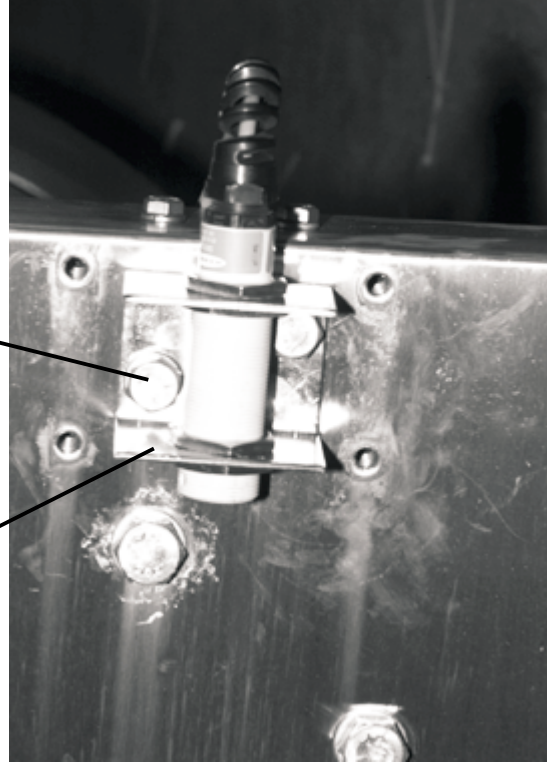


REAR VIEW OF SHELLFRONT

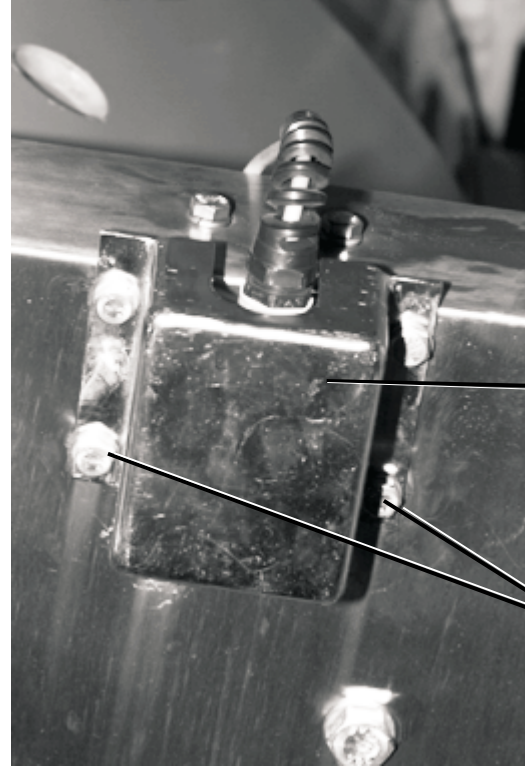


011A

021,022



DETAIL-A  
ASSEMBLY PRIOR TO MOUNTING COVER-  
ITEM 011 AS SHOWN BELOW





Pellerin Milnor Corporation  
P. O. Box 400, Kenner, LA 70063-0400

Litho in U.S.A.

**Parts List—Shell Assembly**

Find the correct assembly first, then find the needed components. The item letters (A, B, C, etc.) assigned to assemblies are referred to in the "Used In" column to identify which components belong to an assembly. The item numbers (1, 2, 3, etc.) assigned to components relate the parts list to the illustration.

Used In	Item	Part Number	Description	Comments
			-----ASSEMBLIES-----	
	A	ASE16001	*SHELL ASSY 4232 M7E	
			-----COMPONENTS-----	
all	1	W3 16073	*WLDMT=SHELLFRONT 42M7E	
all	2	W3 16027	*SHELL WELDMENT 42M7E	
all	3	15K227M	HEXCPSCR 5/8-11 X 8.5 SS	
all	4	15K227G	HEXCAPSCR 5/8-11X5+1/2 SS-18-8	
all	5	15U318S	FLATWASH 1.12ODX.656IDX.09T 30	
all	6	15U315S	LOKWASHER MEDIUM 5/8 18-8 S/S	
all	7	15G236B	HEX NUT 5/8-11UNC2B BRASS	
all	8	02 11153A	GASKET=46"BCX1/8THK=4/42Q+D	
all	9	03 16313A	EXCURSION SW PLT 42M7E	
all	11	W3 16431	*WLMT=PHOTOEYE COVER 42M7E	
all	11	03 16432	PHOTOEYE MNT BRKT 42M7E	
all	12	15U245	FLTWASH 3/8 STD COMM 18-8 SS	
all	13	15U260	LOCKWASHER MEDIUM 3/8 SS18-8	
all	14	15K083S	HXCAPSCR 3/8-16NCX1/2 SS18-8	
all	15	15K084	TRUSS HXSOK 3/8-16 X 23/32SS	
all	16	15U240	FLATWASHER(USS STD) 3/8" ZNC P	
all	17	15U255	LOCKWASHER MEDIUM 3/8 ZINCPL	
all	18	15G205	HXNUT 3/8-16UNC2B ZINC GR2	
all	19	15U260	LOCKWASHER MEDIUM 3/8 SS18-8	
all	20	15K096	HEXCAPSCR 3/8-16UNC2X1SS18-8	
all	21	15K146	HEX CAP SCR 1/2-13 UNC2 X 1 SS	
all	22	15U310	LOKWASHER REGULAR 1/2 SS18-8	
all	23	09RPELKNUT	LOCKNUT MICRO SWITCH #925NZ30	

# Load Chute Installation

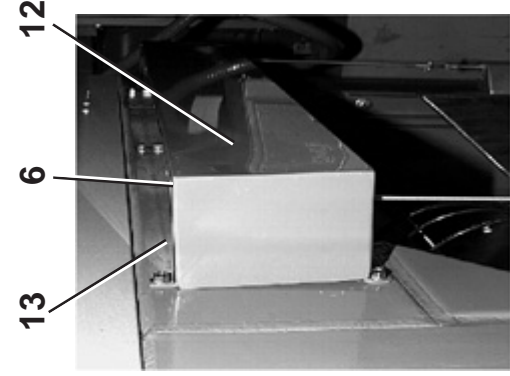
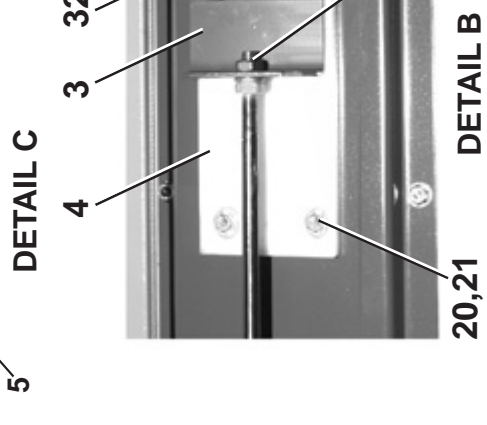
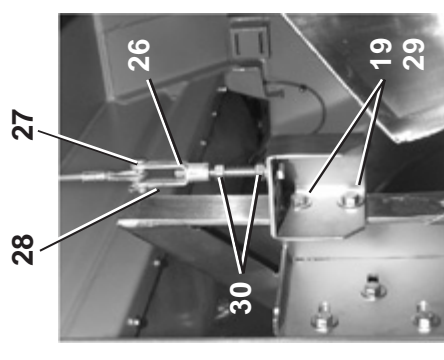
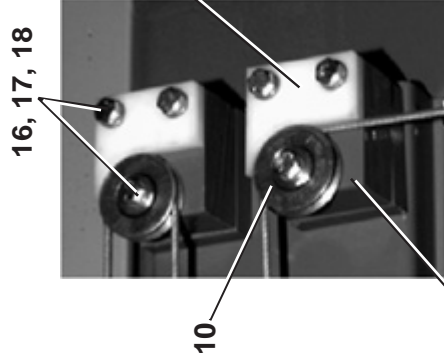
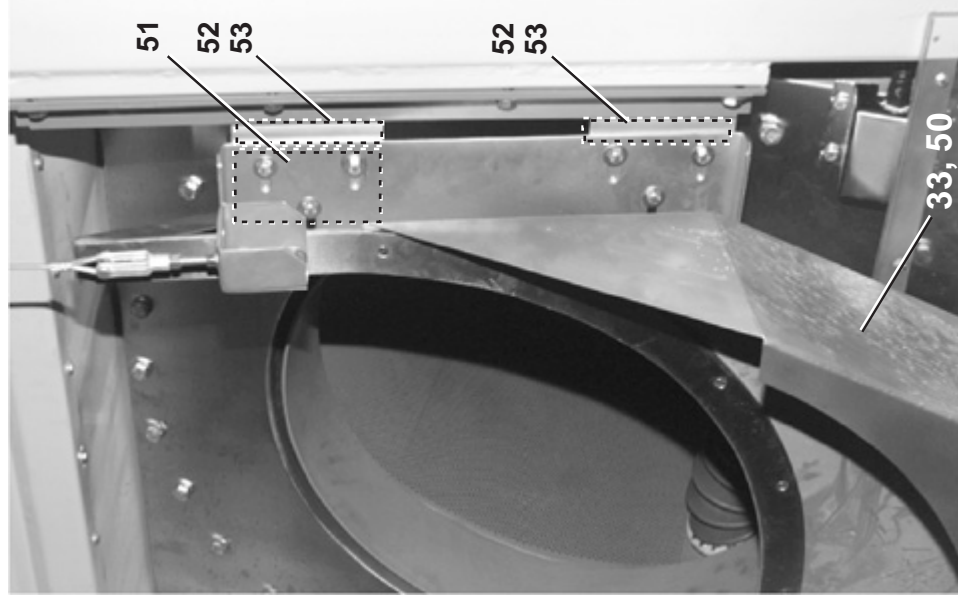
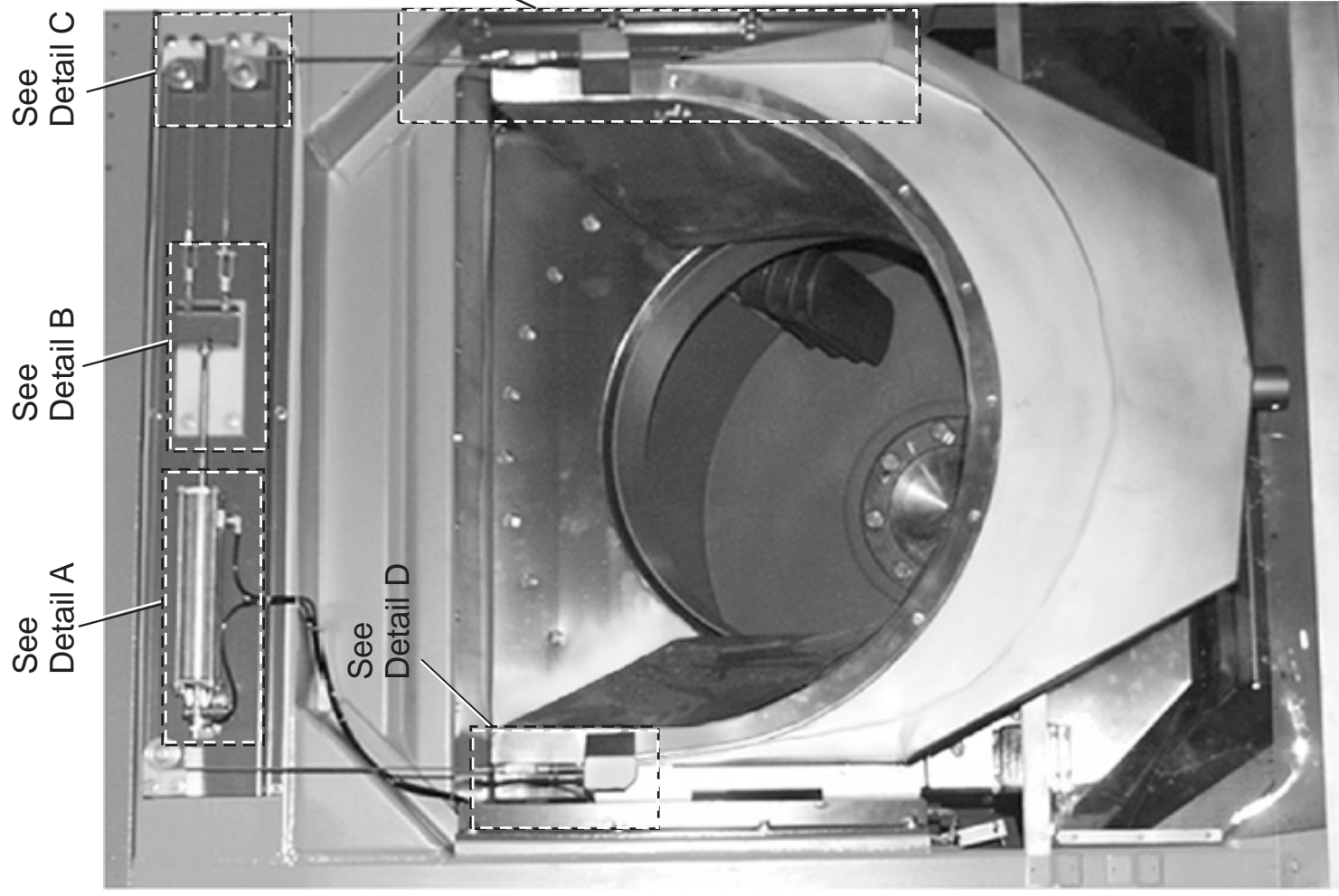
M7V4232CL,CR,L,R M9V4232CL,CR,L,R MMV4232CL,CR,L,R MXV4232CL,CR,L,R

BMP960009/2008105B  
(Sheet 1 of 2)



Pellerin Milnor Corporation  
P. O. Box 400, Kenner, LA 70063-0400

Litho in U.S.A.



See Detail E

See Detail C

See Detail B

See Detail A

See Detail D



**Pellerin Milnor Corporation**  
P. O. Box 400, Kenner, LA 70063-0400

Litho in U.S.A.

Parts List—Load Chute Installation				Parts List, cont.—Load Chute Installation			
Used In	Item	Part Number	Description	Used In	Item	Part Number	Description
Find the correct assembly first, then find the needed components. The item letters (A, B, C, etc.) assigned to assemblies are referred to in the "Used In" column to identify which components belong to an assembly. The item numbers (1, 2, 3, etc.) assigned to components relate the parts list to the illustration.							
			ASSEMBLIES-----				
A		GCL16002	95036B INST=LOAD CHUTE (CABLE)				
B		ACL16001	93463B ASSY=LOAD CHUTE 42M7E				
-----COMPONENTS-----							
all	1	W3 16533	94533C*WLMT=LD CHT LIFT BKT-L		28	17A030	CLEVISPIN 3/8"X1+3/32"DRILLED
all	2	W3 16533A	94533C*WLMT=LD CHT LIFT BKT-R		29	15U240	FLATWASHER(USS STD) 3/8" ZNC PLT
all	3	03 16535	95392C AIR CYL TO CABLE BKT		30	15G214	HXJAMNUT 3/8-16UNC2B SAE ZINC GR2
all	4	03 16536	94533C UHMMW AIR CYL BKT GUIDE		31	AAC03001	AIRCYL DBLACT=S/S HWD
all	5	03 16537	95427B LD CHT LIFT PULLEY SPACER		32	15K121	HXTAPBOLT 3/8-16UNC2X2" GR5 ZIN/CAD
all	6	03 16538	94533D LD CHT LIFT COVER-TOP		33	ACL16001	93463B ASSY=LOAD CHUTE 42M7E
all	7	15P003	TRDCUT-F FLATHD 6-32UNC2X3/8 ZINCPL		34	03 16218	92481C OUTER RAIL BRKT=LOAD CHUTE
all	8	W3 16539	94000Z*WLMT=LD CHUTE LIFT MTG PLATE		35	03 16219	92803C OUTER MNT BRKT=LOAD CHUTE RT
all	9	15P200	02Z TRDCUT-F HXWASHD 3/8-16X3/4NIK		36	03 16277	95053B TARGET-SCOOP 42M7E
all	10	27A965	PULLEY-ZC.PLATED-CPS650		37	03 16317	92563B SCOOP PHOTOEYE MTG ANGLE
all	11	07 40935A	94517# UHMMW PULLEY CABLE GUIDE PRES		38	03 16276	93101L SWITCH MTG BRKT-SCOOP 42M7E
all	12	W3 16542	94533D*WLMT=LD CHT LIFT COVER		39	03 16327	92632C SCOOP=FRNT PLASTIC GRD 42M7E
all	13	15K085	HEXCAPSCR 3/8-16UNC2AX3/4 GR5 ZINC		40	53A031XB	BODY-EL90MALE.25X25 #269C-4-4B
all	14	ASC16000	95000Z ASSY= SCOOP LIFT CABLE SHORT		41	5N0ECLSBE2	NPT NIP 1/4XCLS TBE BRASS 125#
all	15	ASC16000A	95000Z ASSY= SCOOP LIFT CABLE LONG		42	5SCC0EBE	NPT COUP 1/4 BRASS 125# #103
all	16	15K140	HXCAPSCR 3/8-16UNC2AX4 ZINC GRADE 5	B	50	W3 16201	95266D*WLMT=LOAD CHUTE SCOOP 42M7E
all	17	15U255	LOCKWASHER MEDIUM 3/8 ZINCPL	B	51	03 16211	92613B RAIL ADJUST PLT 42M7E
all	18	15G205	HXNUT 3/8-16UNC2B ZINC GR2	B-	52	03 16212	92443B NYLON SLIDE STRIP FRNT 42M7E
all	19	15K105	HXCAPSCR 3/8-16UNC2A1.25 GR5 PLATED	B-	53	03 16213	92443B NYLON SLIDE STRIP BACK 42M7E
all	20	15K041	HXCAPSCR 1/4-20UNC2AX1 GR 5 ZINC/CD				
all	21	15G165	HXNUT 1/4-20UNC2BSAE ZC GR2				
all	22	15U180	LOCKWASHER MEDIUM 1/4 ZINCPL				
all	23	15U185	FLATWASHER(USS STD) 1/4" ZNC PLT				
all	24	15G231	HXFINJAMNUT 1/2-13UNC2B ZINC GR2				
all	25	15B107	HEXTAPBOLT 3/8-16UNC2X3+1/2 ZNC GR5				
all	26	17A010	ADJ CLEVIS MACHINED 3/8-16 ZNC PLT				
all	27	15H040	STDCOTTERPIN 1/8X3/4 ZINCPL				

# Load Chute Assembly

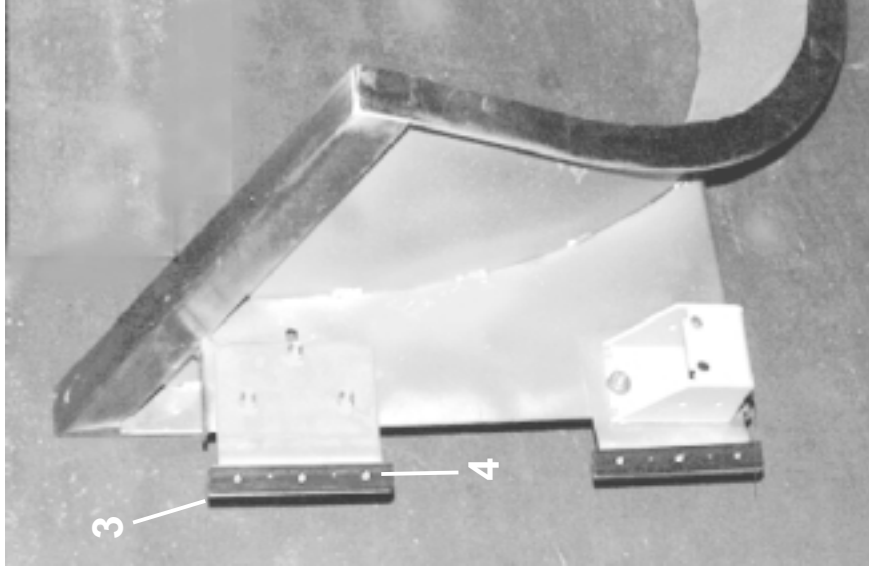
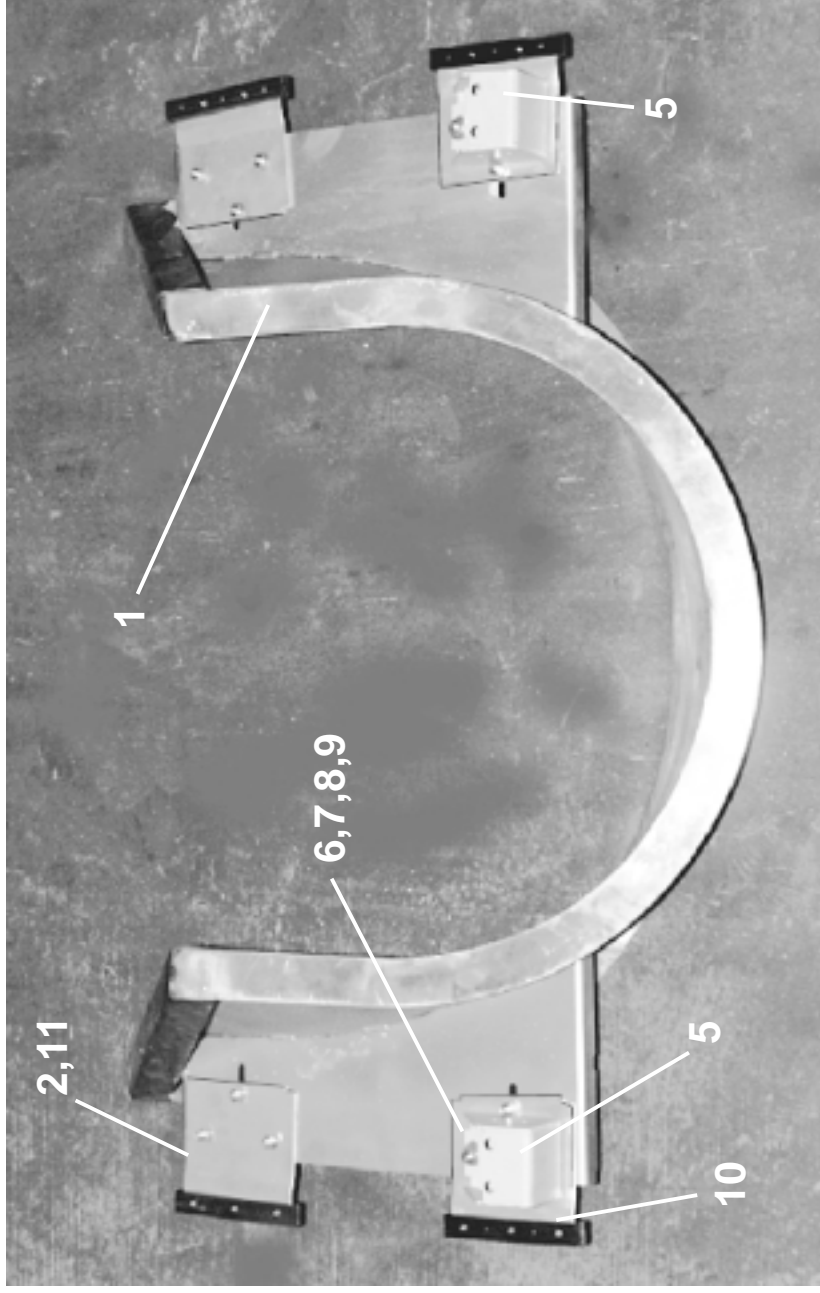
M7E4232C,L,R M9E4232C,L,R M7V4232C,L,R M9V4232C,L,R

BMP940021/2001204V  
(Sheet 1 of 2)



Pellerin Milnor Corporation  
P. O. Box 400, Kenner, LA 70063-0400

Litho in U.S.A.





Pellerin Milnor Corporation  
P. O. Box 400, Kenner, LA 70063-0400

Litho in U.S.A.

**Parts List—Load Chute Assembly**

Find the correct assembly first, then find the needed components. The item letters (A, B, C, etc.) assigned to assemblies are referred to in the "Used In" column to identify which components belong to an assembly. The item numbers (1, 2, 3, etc.) assigned to components relate the parts list to the illustration.

Used In	Item	Part Number	Description	Comments
			-----ASSEMBLIES-----	
	A	ACL16001	ASSY=LOAD CHUTE 42M7E	
			-----COMPONENTS-----	
all	1	W3 16201	*WLMT=LOAD CHUTE SCOOP 42M7E	
all	2	03 16211	RAIL ADJUST PLT 42M7E	
all	3	03 16212	NYLON SLIDE STRIP FRNT 42M7E	
all	4	03 16213	NYLON SLIDE STRIP BACK 42M7E	
all	5	W3 16215	WLMT=AIR CYL SUP RT 42M7E	
all	6	15K083S	HXCAPSCR 3/8-16NCX1/2 SS18-8	
all	7	15U245	FLTWASH 3/8 STD COMM 18-8 SS	
all	8	15U260	LOCKWASHER MEDIUM 3/8 SS18-8	
all	9	15G206	HEXNUT 3/8-16 UNC2 SS 18-8	
all	10	15J051AL	POPRIVET 1/8DIAX.765L	
all	11	03 16332	SCOOP= MTG BRKT SHIMS	

Extractor Auto Load Door

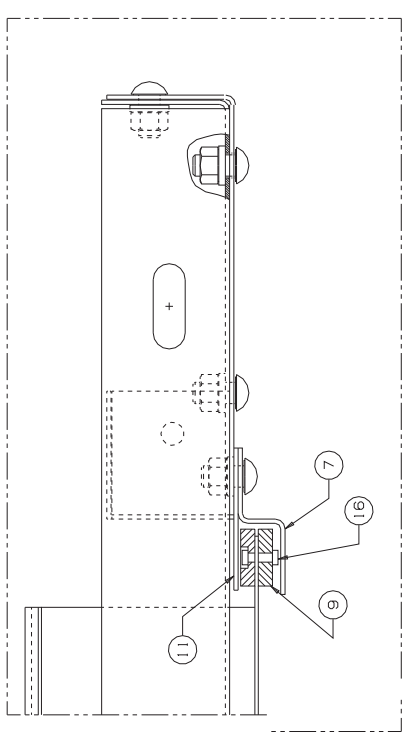
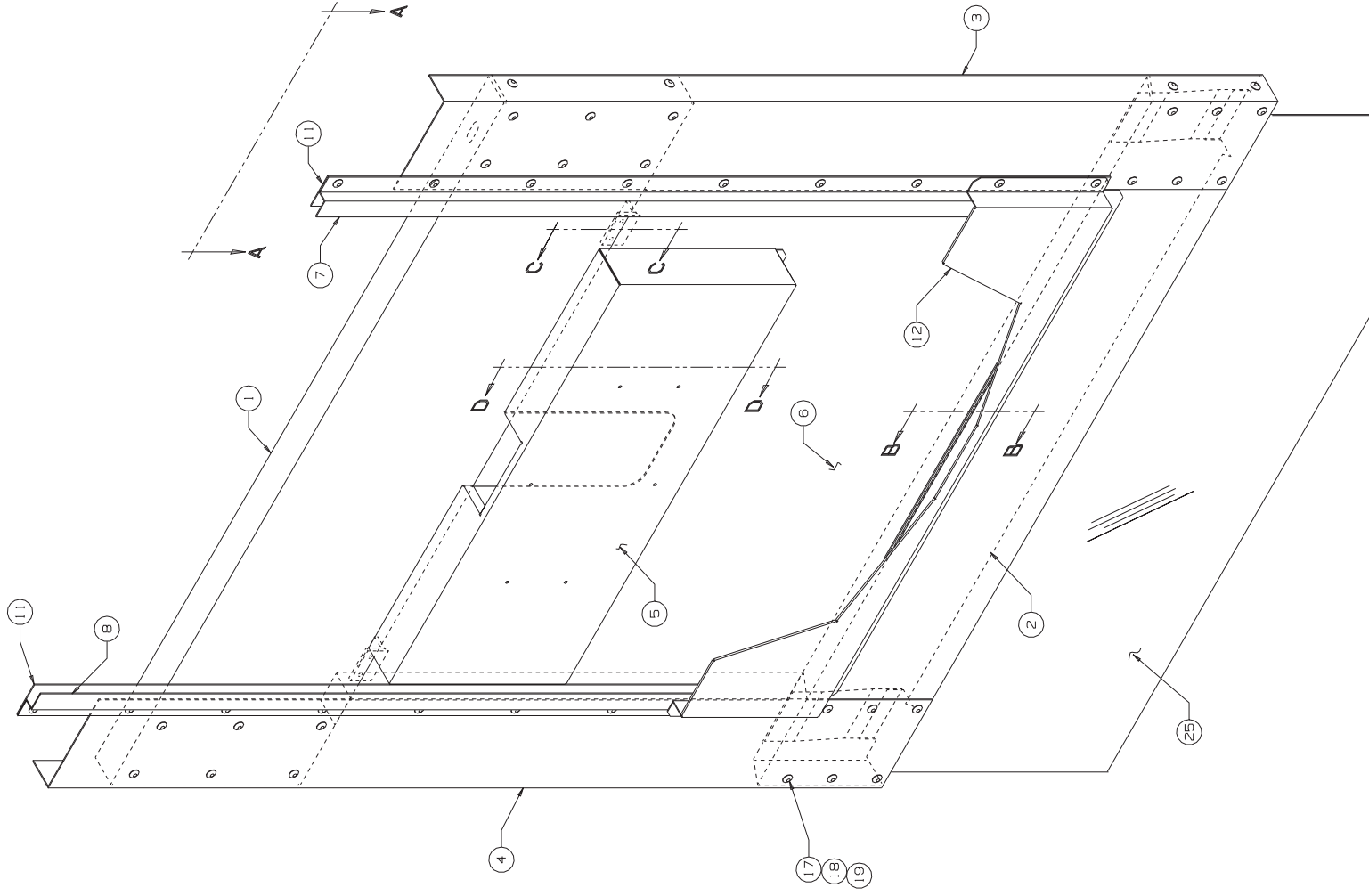
M7E4232C,L,R M9E4232C,L,R M7V4232C,L,R M9V4232C,L,R **MXS4232C,L,R**



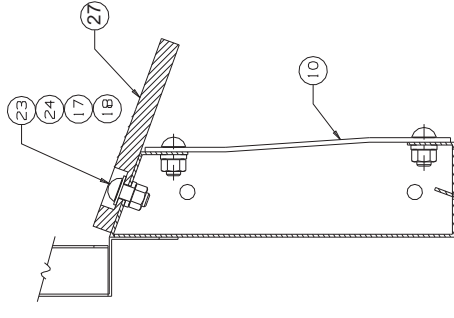
**Pellerin Milnor Corporation**  
P. O. Box 400, Kenner, LA 70063-0400

**BMP990010/2013285B**  
(Sheet 1 of 2)

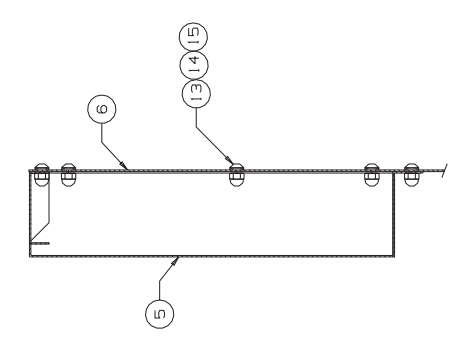
Litho in U.S.A.



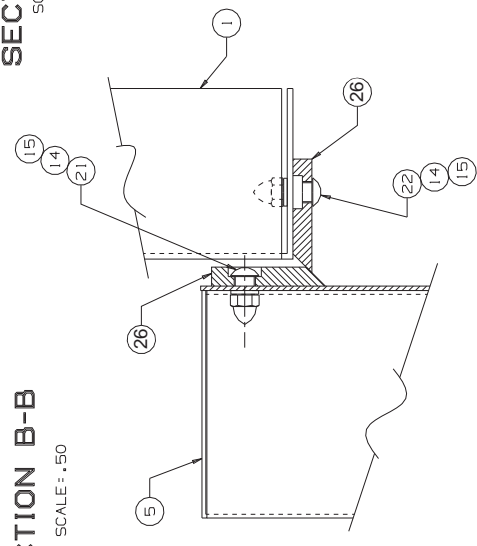
**VIEW A-A**  
SCALE: .75



**SECTION B-B**  
SCALE: .50



**SECTION D-D**  
SCALE: .375



**SECTION C-C**  
SCALE: FULL





**Pellerin Milnor Corporation**  
P. O. Box 400, Kenner, LA 70063-0400

Litho in U.S.A.

**Parts List—Auto Load Door**

Find the correct assembly first, then find the needed components. The item letters (A, B, C, etc.) assigned to assemblies are referred to in the "Used In" column to identify which components belong to an assembly. The item numbers (1, 2, 3, etc.) assigned to components relate the parts list to the illustration.

Used In	Item	Part Number	Description	Comments
			-----ASSEMBLIES-----	
	A	ASD16000	EXTRACTOR DOOR ASSY 42M7E	
			-----COMPONENTS-----	
all	1	03 16289	EXTR DOOR TOP PLATE 42M7E	
all	2	03 16290	EXTR DOOR BOTT CHNL 42M7E	
all	3	03 16291	EXTR DOOR RT SIDE CHNL 42M7E	
all	4	03 16291A	EXTR DOOR LF SIDE CHNL 42M7E	
all	5	03 16292	EXTR DOOR COVER 42M7E	
all	6	03 16293	EXTR DOOR 42M7E	
all	7	03 16294	EXTR DOOR GUIDE CHNL RT 42M7	
all	8	03 16294A	EXTR DOOR GUIDE CHNL LFT 42M	
all	9	03 16297	EXTR DOOR PLASTIC STRIPS	
all	10	03 16310	DOOR=BOTTOM SILL STFNR 42M7E	
all	11	03 16311	DOOR= GUIDE CHNL REAR 42M7E	
all	12	03 16316	DOOR=FRONT SCUPPER	
all	13	15K032	BUTSOKCAPSCR 1/4-20X3/8 SS18-8	
all	14	15G140S	HEXCAPNUT(ACORN) 1/4-20 SS 18-	
all	15	15U181	LOCKWASHER MEDIUM 1/4 SS18-8	
all	16	15J051	POPRIVET 1/8DIAX.265 LONG S/S	
all	17	15U260	LOCKWASHER MEDIUM 3/8 SS18-8	
all	18	15G206	HEXNUT 3/8-16 UNC2 SS 18-8	
all	19	15K083V	BUTSOKCAPSCR 3/8-16X3/4 SS18-8	
all	20	15K086	HXCAPSCR 3/8-16NCX3/4 SS18-8	
all	21	15K031	BUTSOKCAPSCR 1/4-20X1/2 SS18-8	
all	22	15K180S	HXCAPSCR 1/2-13UNCAX2 18-8SS	
all	23	15K091F	BUTSOKCAPSCR 3/8-16X1 BRASS E=	
all	24	15U245	FLTWASH 3/8 STD COMM 18-8 SS	
all	25	03 16287A	PLASTIC FRNT GUARD 24X55.25	
all	26	03 16338	DOOR = UHMW WEDGE	
all	27	03 16290A	DOOR TRANSFER UHMW	
all	28	27C215	AIR CYL 1.5"BORE X 34" STROKE	
all	29	15G239	HXNUT 3/4-16UNF2B SAE ZINC GR2	
all	30	15G214	HXJAMNUT 3/8-16UNC2B SAE ZINC	
all	31	15U238	LOKWAS INTOOTH 3/8" (US STD) 4	
All	32	96N0013HU	SHUTLVLV 1/4" 4WAY CENTER-OFF	

**Cosmetic Covers**

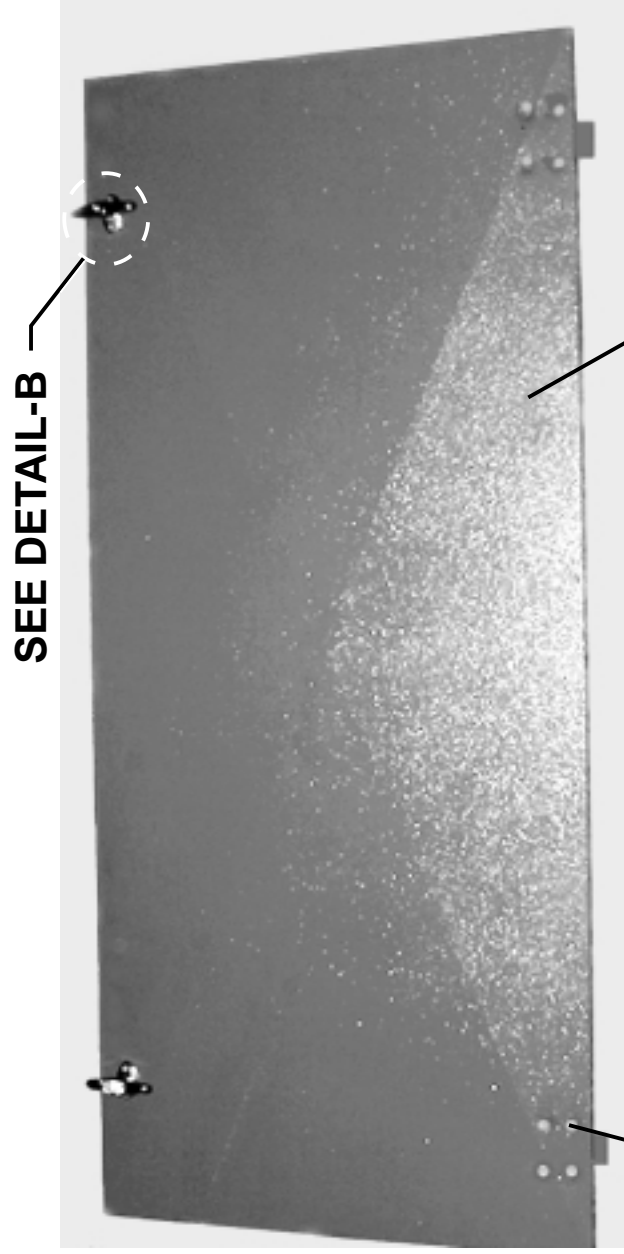
**M7E4232C,L,R M9E4232C,L,R M7V4232C,L,R M9V4232C,L,R**

BMP940017/2001204V  
(Sheet 1 of 2)



Pellerin Milnor Corporation  
P. O. Box 400, Kenner, LA 70063-0400

Litho in U.S.A.



SEE DETAIL-B

OUTSIDE OF DOOR

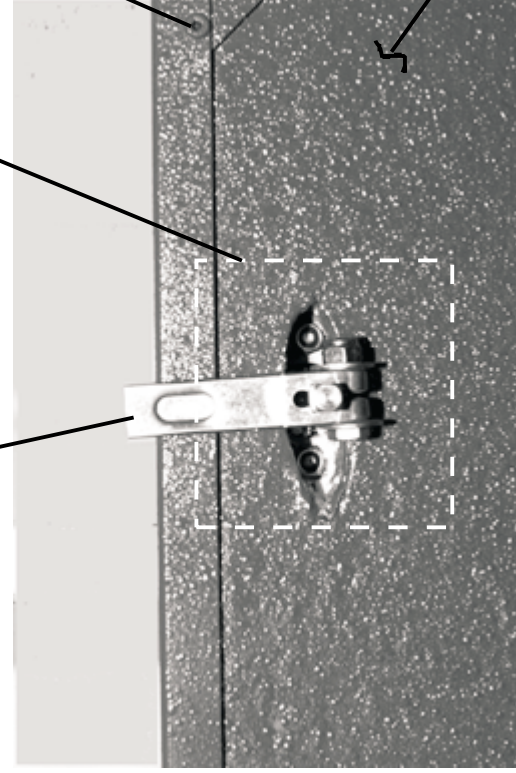
001

005,006  
007,008

012

010

011



DETAIL-A



SEE DETAIL-A

INSIDE OF DOOR

009,012

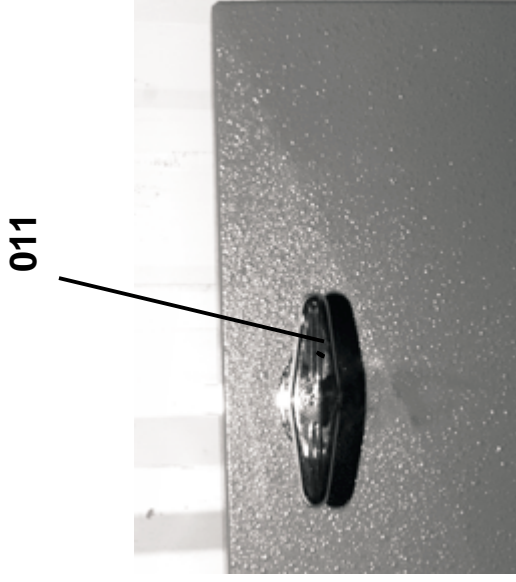
SEE DETAIL-C

001

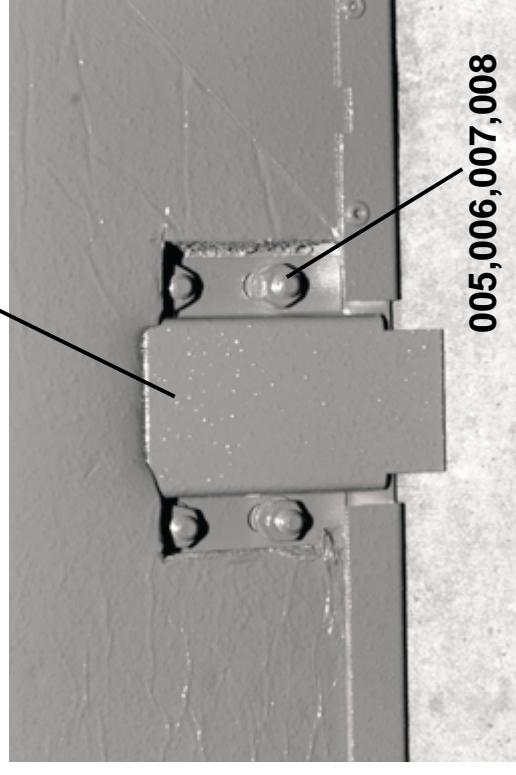
010

011

013



DETAIL-B



DETAIL-C



Pellerin Milnor Corporation  
P. O. Box 400, Kenner, LA 70063-0400

Litho in U.S.A.

**Parts List—Cosmetic Covers**

Find the correct assembly first, then find the needed components. The item letters (A, B, C, etc.) assigned to assemblies are referred to in the "Used In" column to identify which components belong to an assembly. The item numbers (1, 2, 3, etc.) assigned to components relate the parts list to the illustration.

Used In	Item	Part Number	Description	Comments
-----ASSEMBLIES-----				
	A	AGS16000	ASSY=COSM COVER 79.19X40.81	
	B	AGS16003	ASSY=COSM COVER 69.50X40.81	
	C	AGS16004	ASSY=COSM COVER 65.48X28.25	
	D	AGS16006	ASSY=COSM COVER 32.62X80.06	
	E	AGS16007	ASSY=COSM COVER 34.06X79.19	
-----COMPONENTS-----				
A	1	03 16266	COSM=LARGE DOOR 42M7E	
B	1	03 16266A	COSM=LFT LARGE DOOR 42M7E	
C	1	03 16267	COSM=SMALL DOOR 42M7E	
D	1	03 16436	SIDE UNLOAD COSM REAR DOOR	
E	1	03 16435	UNLOAD SIDE LONG DOOR	
all	3	02 11378	CORNER GUSSET=COVER	
all	4	98P050	INSULATION BRD 4X8X1+1/16E=	
all	5	15K095	HXCPSCR 3/8-16UNC2AX1 GR5 ZINC	
all	6	15U240	FLATWASHER(USS STD) 3/8" ZNC P	
all	7	15U255	LOCKWASHER MEDIUM 3/8 ZINCPL	
all	8	15G205	HXNUT 3/8-16UNC2B ZINC GR2	
all	9	02 11424	INSULTN RETNR=50 COVRS 42QHE	
all	10	02 11807	STIFF=COSMETIC COVER	
all	11	27A012LTKL	LOCK" T"HANDL,L.LTCH&MTGHDW	
all	12	15J050AL	POPRIVET 1/8DIA X.328LONG ALUM	
all	13	07 70134A	3" BASE=COVER HANGER BRKT	



# Drive Assemblies

3

# Drive Chart

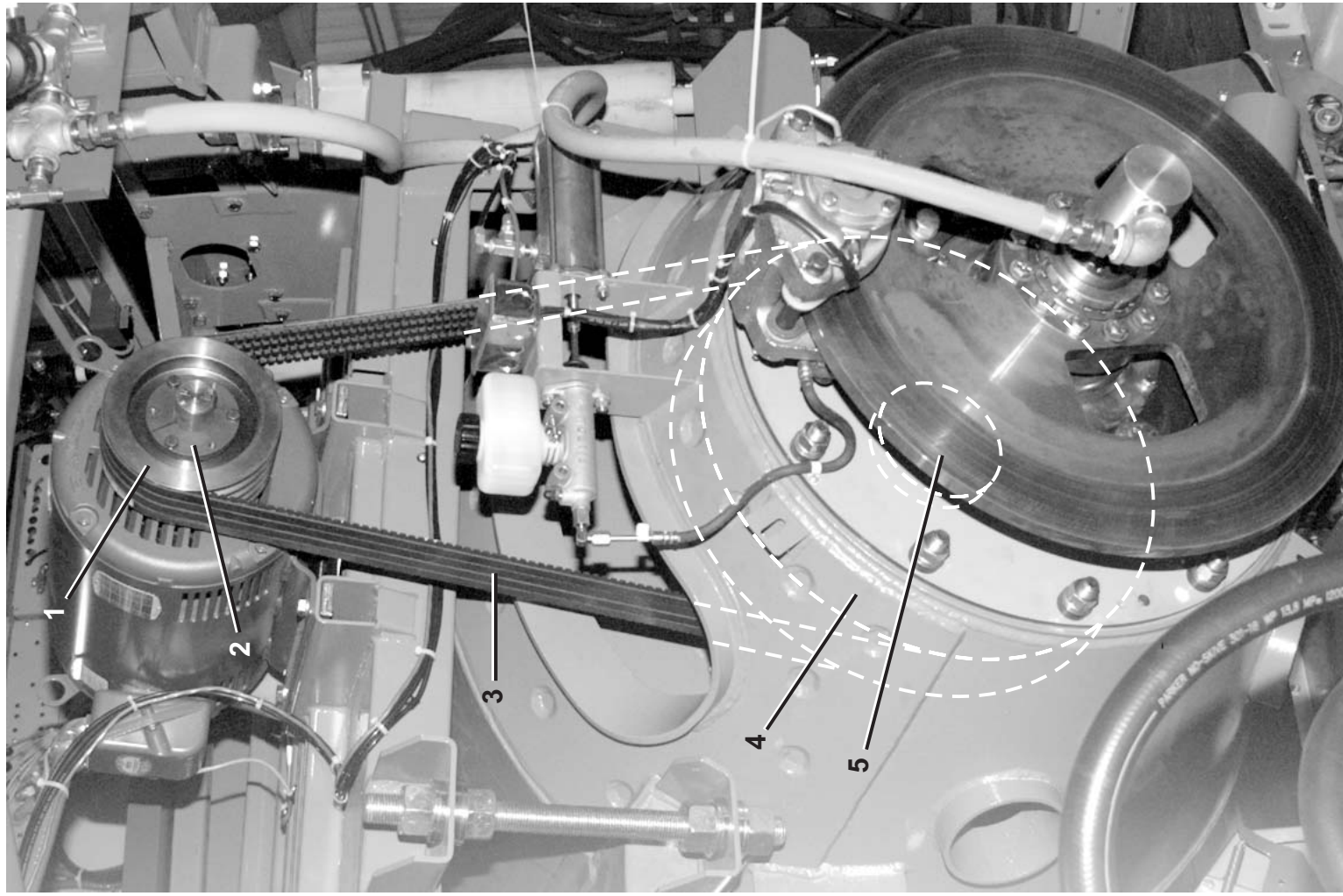
M9V4232C,L,R **MMV4232C,L,R** **MXV4232C,L,R**



**Pellerin Milnor Corporation**  
P. O. Box 400, Kenner, LA 70063-0400

**BMP000039/2009443B**  
(Sheet 1 of 1)

Litho in U.S.A.



## Parts List—Drive Chart

Find the correct assembly first, then find the needed components. The item letters (A, B, C, etc.) assigned to assemblies are referred to in the "Used In" column to identify which components belong to an assembly. The item numbers (1, 2, 3, etc.) assigned to components relate the parts list to the illustration.

Used In	Item	Part Number	Description	Comments
-----ASSEMBLIES-----				
A		ADB16002	DRIVE BASE ASSY 42E7P SINGL MTR	M9V4232C,L,R
B		ADB16003	DRIVE BASE ASSY 42MXV SM	MMV4232C,L,R MXV4232C,L,R
-----COMPONENTS-----				
A	1	56070B4SK	VPUL 4B7.0/A6.6 (SK) TYPE QD	
B	1	56070B4SKD	VPUL 4B7.0/A6.6 (SK)QD DUCTILE	
A	2	56Q1MSK	1+5/8" BUSH VPUL QD TYPE SK	
B	2	56Q1RSK	1+7/8" BUSH VPUL QD TYPE SK	
all	3	56VB112WB4	VBAND RBP112-4 WRAP	
A	4	X3 16216	VPUL 4GB 21.65 - MHUB	
B	4	X3 16216A	VPUL 4GB 21.65-MHUB-DUCTIRON	
all	5	56Q5EM	5+1/4" BUSH VPUL QD TYPE M	

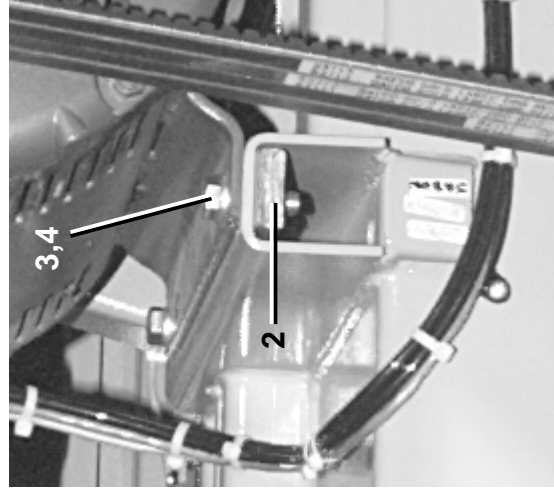
**Drive Base Assembly**  
**M7V4232C,L,R M9V4232C,L,R MXV4232C**

BMP000041/2007166B  
 (Sheet 1 of 2)

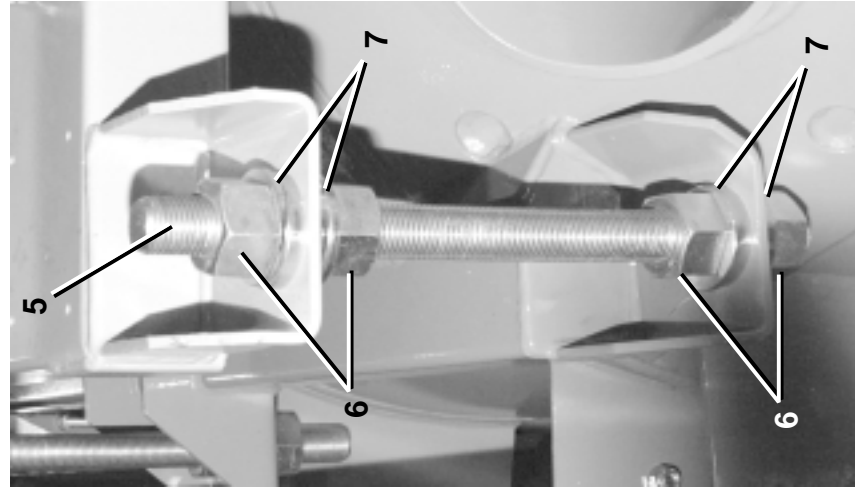


Pellerin Milnor Corporation  
 P. O. Box 400, Kenner, LA 70063-0400

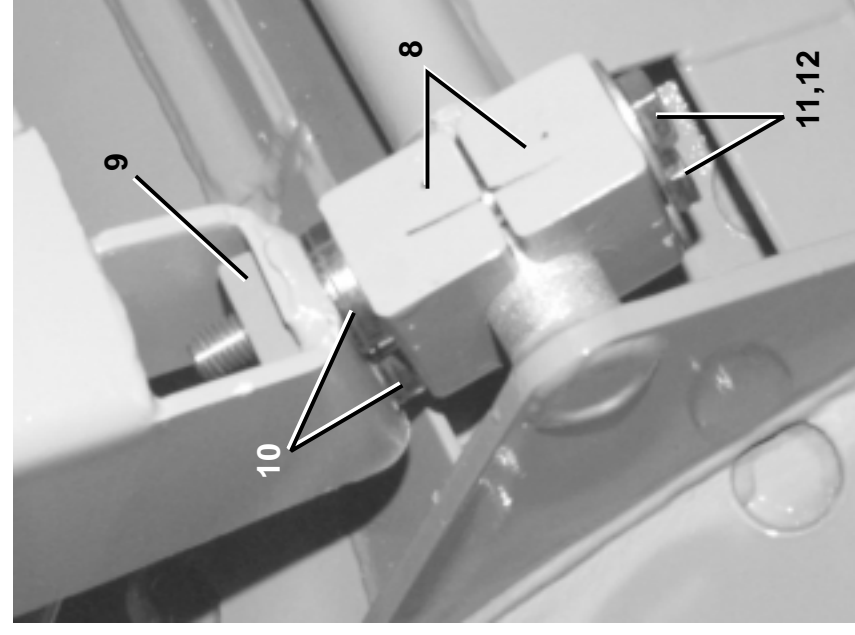
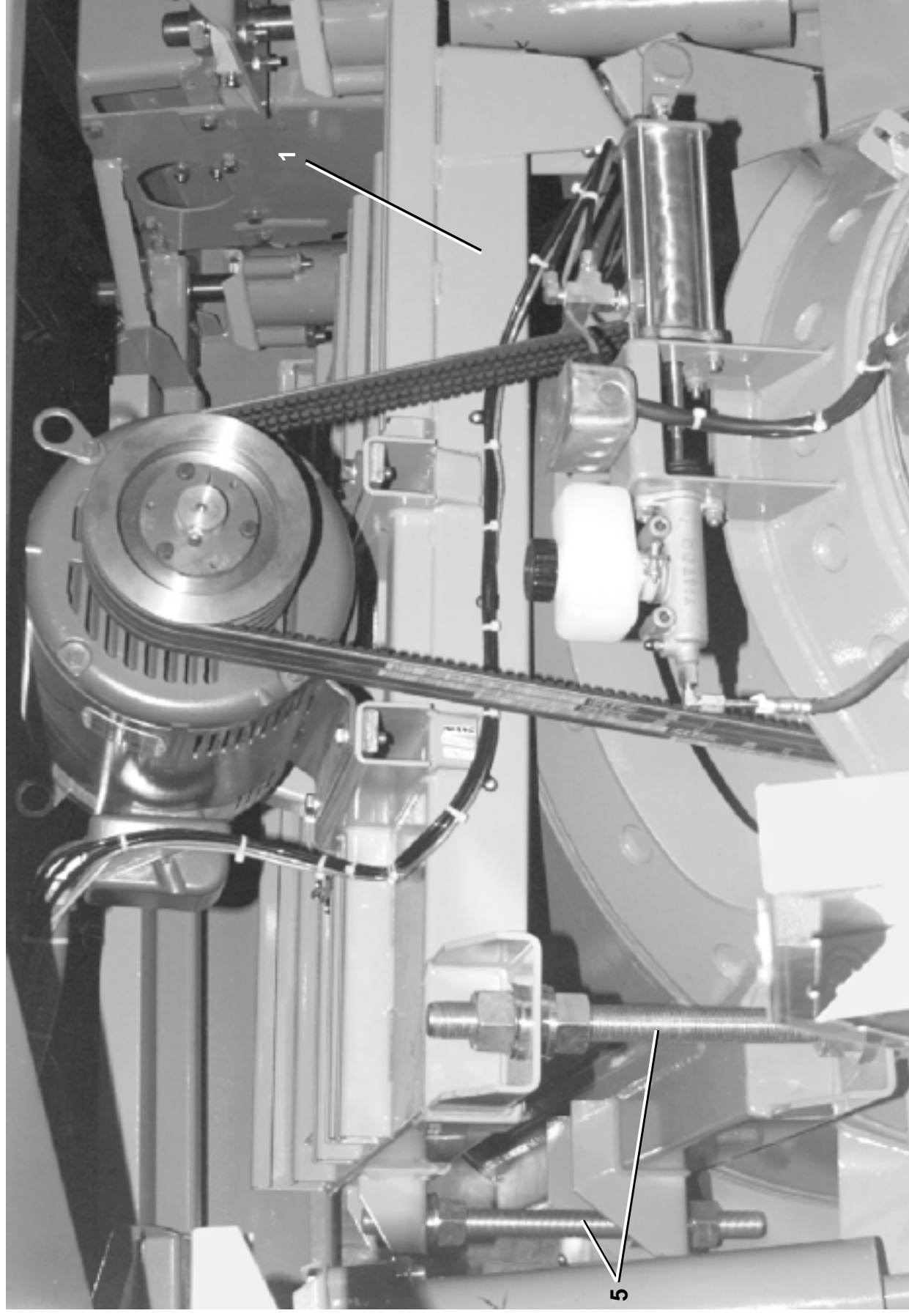
Litho in U.S.A.



TYPICAL MOTOR INSTALLATION



TYPICAL 2 PLACES



TYPICAL 2 PLACES

**Drive Base Assembly**  
**M7V4232C,L,R M9V4232C,L,R MXV4232C**



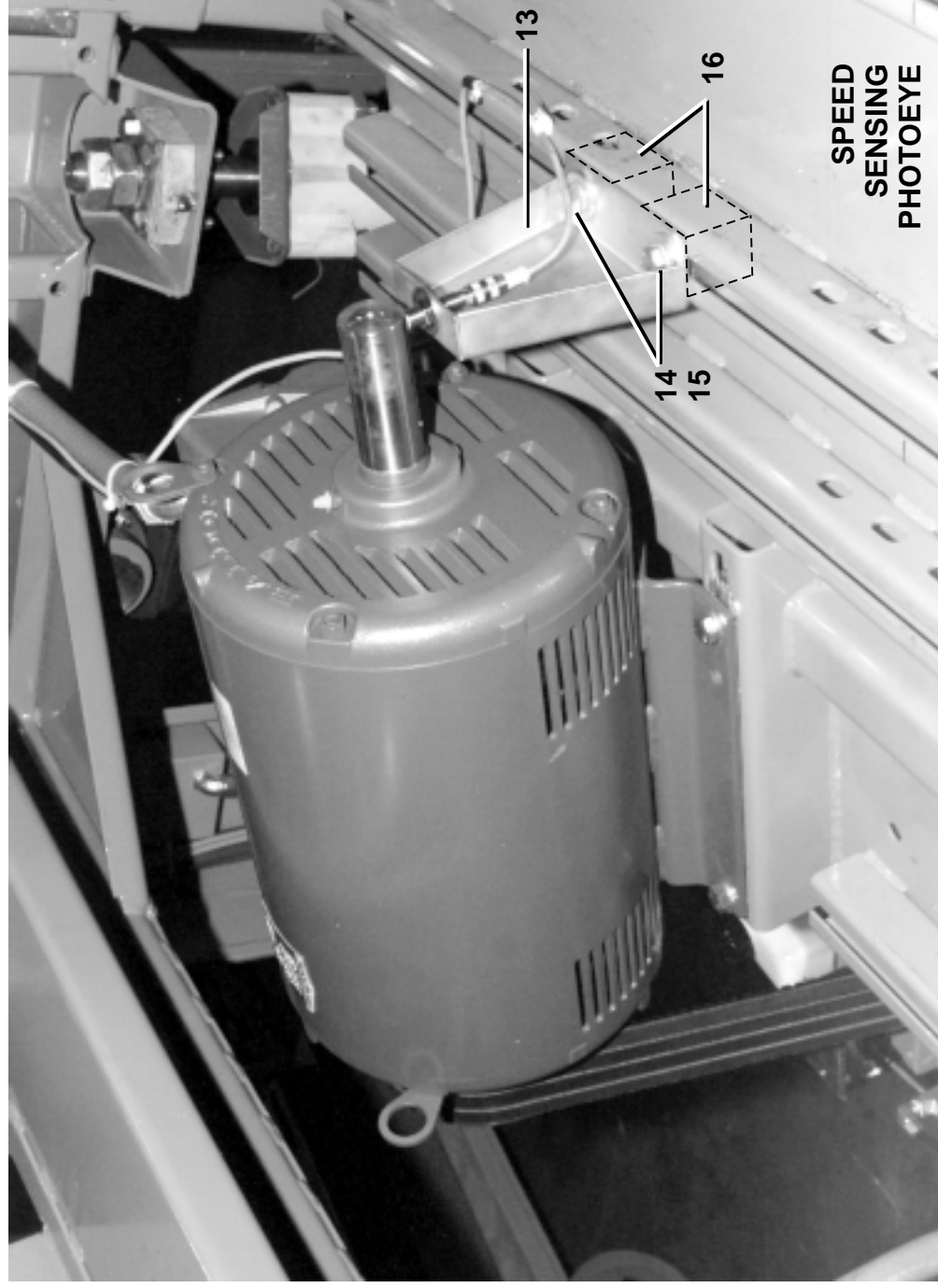
Pellerin Milnor Corporation  
 P. O. Box 400, Kenner, LA 70063-0400

BMP000041/2007166B  
 (Sheet 2 of 2)

Litho in U.S.A.

**Parts List—Drive Base Assembly**  
 Find the correct assembly first, then find the needed components. The item letters (A, B, C, etc.) assigned to assemblies are referred to in the "Used In" column to identify which components belong to an assembly. The item numbers (1, 2, 3, etc.) assigned to components relate the parts list to the illustration.

Used In	Item	Part Number	Description	Comments
	A	ADB16002	DRIVE BASE ASY 42E7P SINGL MTR	
			-----ASSEMBLIES-----	
			-----COMPONENTS-----	
all	1	W3 16138	*MTR MNT WLDMT 4232 MTE	
all	2	02 16322	TAP STRIP-MOTOR MTG	
all	3	15U300	LOKWASHER REGULAR 1/2 ZINC PLT	
all	4	15K173A	HXCAPSCR 1/2-13UNC2AX1.75 GR5	
all	5	17R125A17K	STUD=DRIVEBASEADJ 1+1/4X17.5	
all	6	15G261	HVHXNUT 1+1/4-8UNC2B ZINC GR2H	
all	7	17W125	1+1/4"SPHERICAL WASHER SET	
all	8	C2 11311B	2007033 CAST=MOTOR PIVOT CLAMP, 6836F	
all	9	03 48138	TAP STRIP=MOTOR MNT BRKT 48"	
all	10	17W050	SPHERICALWASHER SET 7/8 M/F	
all	11	15K227D	HXCPCS 5/8-11X6 GR8 ZNC PLT	
all	12	15U314	FLATWASHER(USS STD) 5/8" ZNC P	
all	13	03 16143	DRIVE MTR PROX BRKT	
all	14	15K162	HXCAPSCR 1/2-13UNC2AX1.5 GR5 P	
all	15	15U280	FL+WASHER(USS STD)1/2 ZNC PL+D	
all	16	02 19283	NUT=1/2-13UNCX1+1/25Q SPEC	





## M7V4232x Belt Replacement

This document explains how to replace the drive belt on M7x4232x centrifugal extractors. The other documents referred to in this document can be found in the extractor service manual MAPM7E42BE.



**CAUTION [1]: Crush Hazards**—This procedure requires handling heavy components.

- Handle components with suitable lifting equipment.
- Use the safety stands. (See document BIUUUS06.)

### 1. Resources and Equipment Needed

- Torque wrench to measure 727 Ft-Lbs
- Loctite 242 Thread locker

### 2. Set up

1. Set the shell at the horizontal position and install the short safety stands.
2. Lockout/tagout power and shut off main air.
3. Temporarily support the front of the cylinder (basket) within the shell by tightly inserting six wedges in the gap between the shell front and cylinder door ring. Secure the wedges with large C-clamps equally spaced 60 degrees apart all around the opening (see Shell Assembly document BMP940020). The wedges must prevent the cylinder from moving during the procedure.

### 3. Remove Obstructions

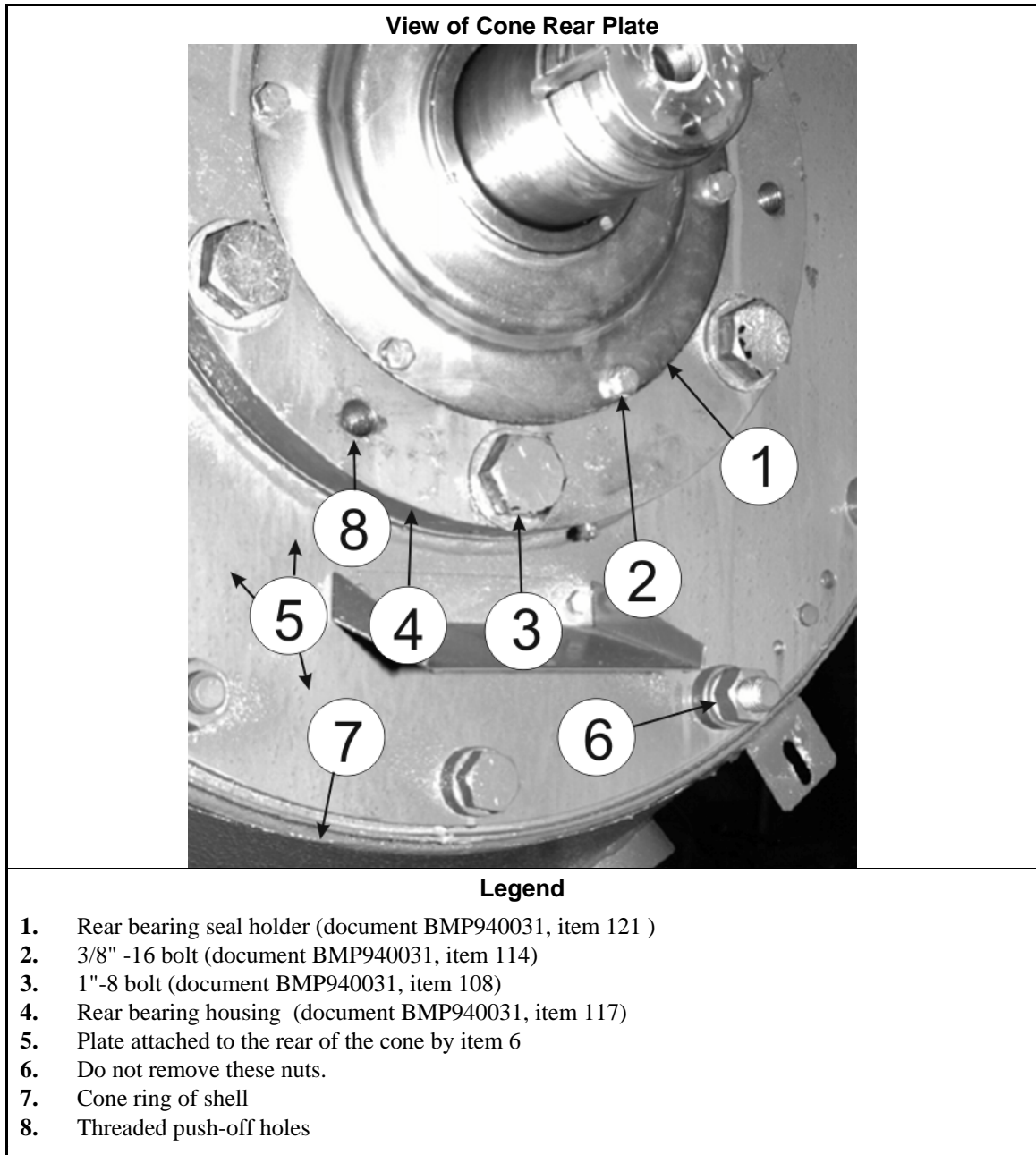
1. Disconnect the air supply line to the rotary coupling on the rear of the main shaft. Then separate the rotary coupling from the shaft by unscrewing the pipe that connects it to the shaft (see Drive Chart, document BMP000039).
2. Remove the disc brake and disc (see Disc Brake Installation, document BMP940018).

### 4. Remove the Rear Bearing Housing but not the Bearing

Refer to Bearing Assembly & Installation, document BMP940031. Remove the rear bearing housing as follows:

1. Work through the hand holes in the cone to unbolt the rear bearing front seal holder (Item 128).
2. Work through the hand holes in the cone to remove the rear bearing grease line and fittings (Items 130 through 135).
3. Unscrew the six bolts (Figure 1, item 3) from the rear bearing housing (Figure 1, item 4) and the plate attached to the rear of the cone (Figure 1, item 5).
4. Insert two of the mounting bolts from the outside, into the threaded push-off holes (Figure 1, item 8) and push the bearing housing (Figure 1, item 4) from the plate (Figure 1, item 5). The bearing will remain on the shaft.
5. Leave the bearing on the shaft. Cover it with a clean rag to protect it from debris.

Figure 1: Components Involved in Disassembly



## 5. Replace the belt

1. Remove the belt guards on top of the machine.
2. Before lowering the drive base, tape the topmost nuts on the drive base adjustment studs to prevent them from moving (see Drive Base Assembly, document BMP000041).
3. Lower the drive base by loosening and lowering the adjustment nuts.
4. Remove the old belt if it is still in place.
5. Install the new belt.

- Pass the belt through the small gap between the rear bearing (document BMP940031, item 129) and the cone ring plate (Figure 1, item 5) .
- Use care to protect the bearing from debris.

## 6. Reassembly

1. Raise the drive base with the adjustment nuts until the base is again tight against the upper nuts. Provided the upper nuts did not move, the belt will be properly tensioned.
2. Replace all other components in reverse order of removal.

**Note 1:** When replacing the bearing housing, be sure to apply Loctite 242 thread locker and torque the bolts to 727 Ft-Lbs as specified in note 1 at the top of document BMP940031.

3. Remove the cylinder wedges.
4. Apply power and main air. Remove the safety stands.

— End of BIPV7M02 —

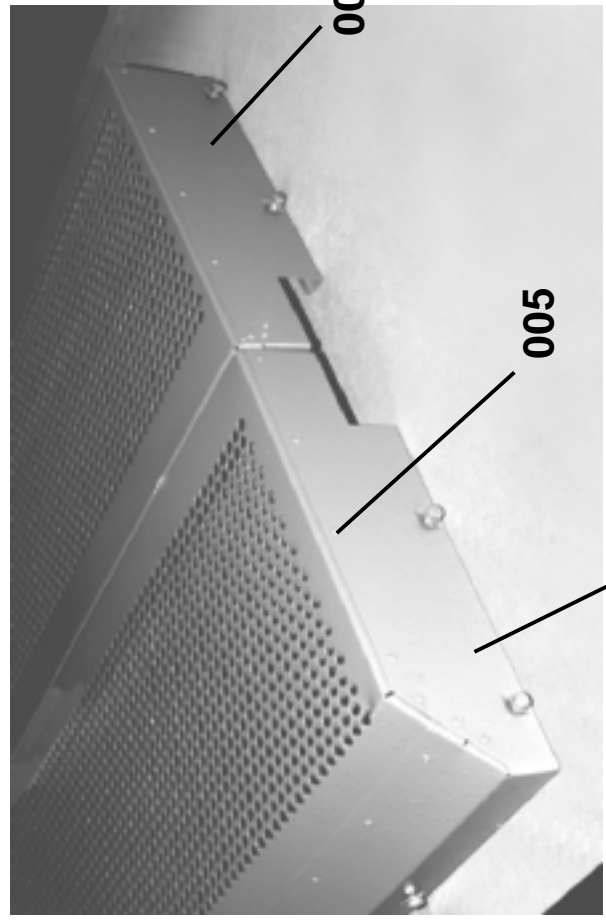
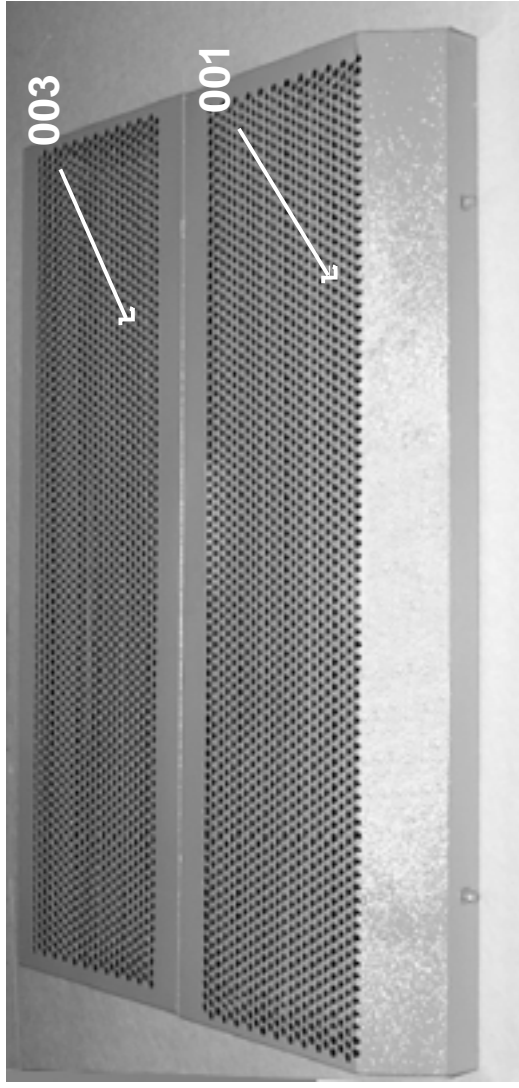
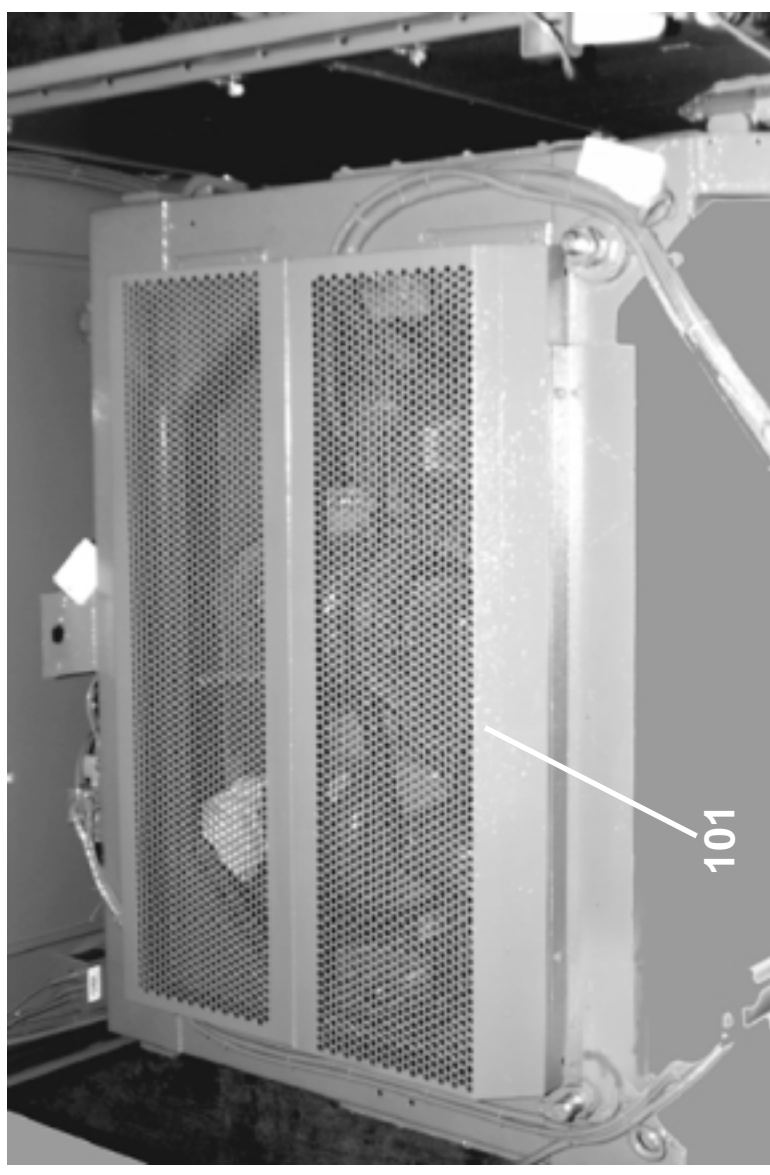
**Belt Guard Installation**  
**M7V4232C,L,R M9E4232C,L,R**

BMP940051/2001204vV  
(Sheet 1 of 2)



Pellerin Milnor Corporation  
P. O. Box 400, Kenner, LA 70063-0400

Litho in U.S.A.





Pellerin Milnor Corporation  
P. O. Box 400, Kenner, LA 70063-0400

Litho in U.S.A.

**Parts List—Belt Guard Installation**

Find the correct assembly first, then find the needed components. The item letters (A, B, C, etc.) assigned to assemblies are referred to in the "Used In" column to identify which components belong to an assembly. The item numbers (1, 2, 3, etc.) assigned to components relate the parts list to the illustration.

Used In	Item	Part Number	Description	Comments
-----ASSEMBLIES-----				
	A	GGs16001	BELTGUARD INSTLL 42E7P	INSTALLATION
	B	AGS16005	DRIVE ENCL ASSY=4232M7E	
-----COMPONENTS-----				
all	1	03 16319	BLTGD= FRONT TOP 42M7E	
all	2	03 16320	BLTGD= FRONT BOTTOM 42M7E	
all	3	03 16321	BLTGD= REAR TOP 42M7E	
all	4	03 16322	BLTGD=REAR BOTTOM 42M7E	
all	5	15J051	POPRIVET 1/8DIAX.265 LONG S/S	
all	101	AGS16005	DRIVE ENCL ASSY=4232M7E	
all	102	15K162	HXCAPSCR 1/2-13UNC2AX1.5 GR5 P	
all	103	15U310	LOKWASHER REGULAR 1/2 SS18-8	

# Disc Brake Installation

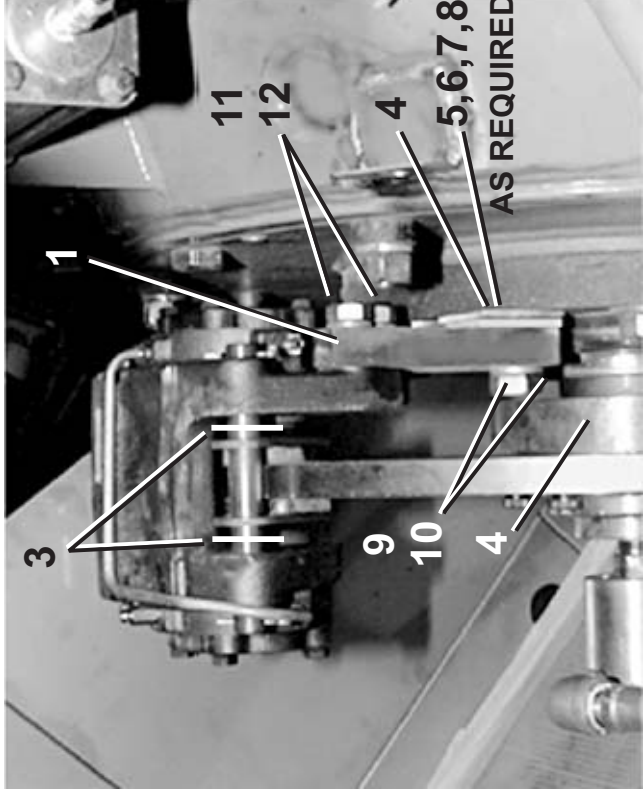
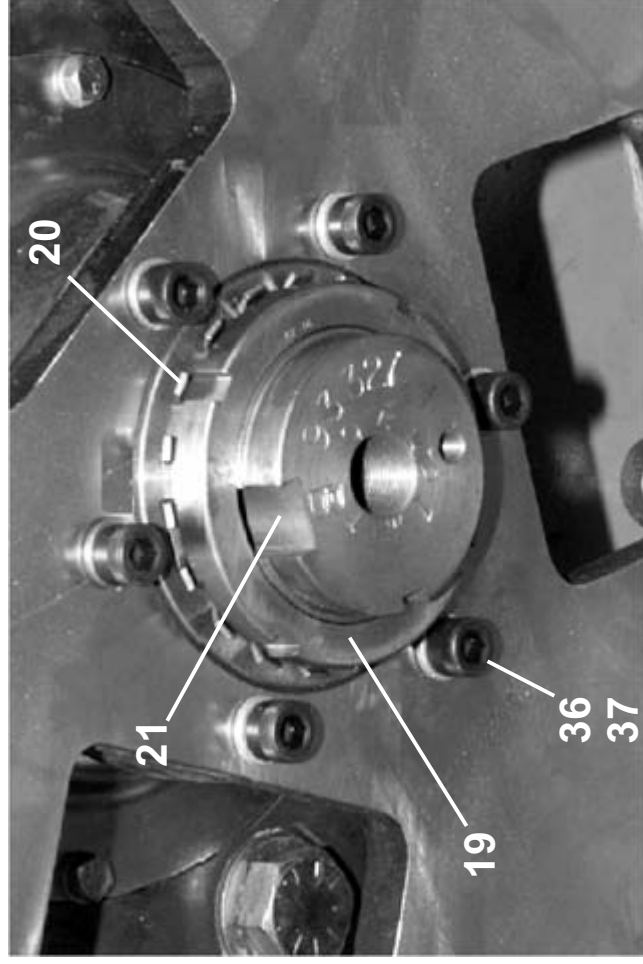
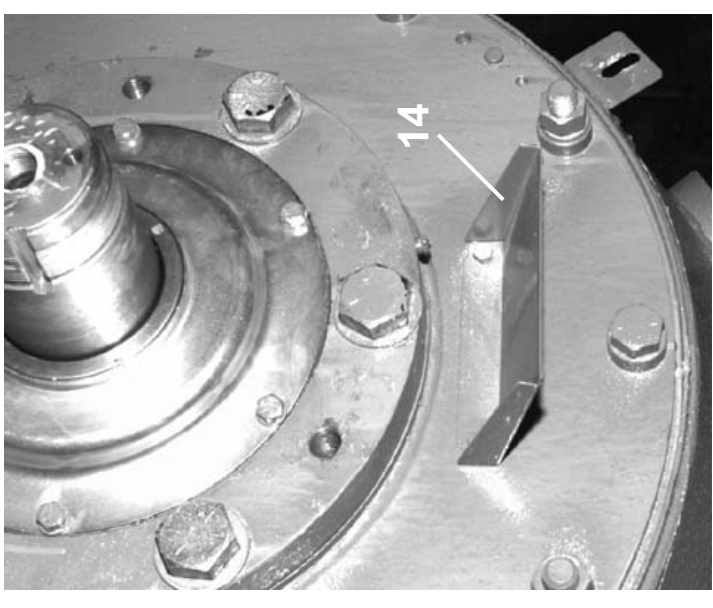
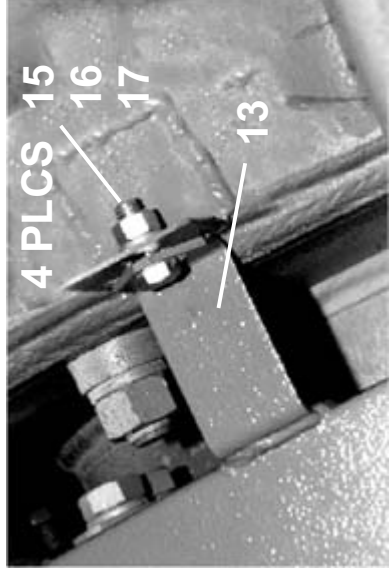
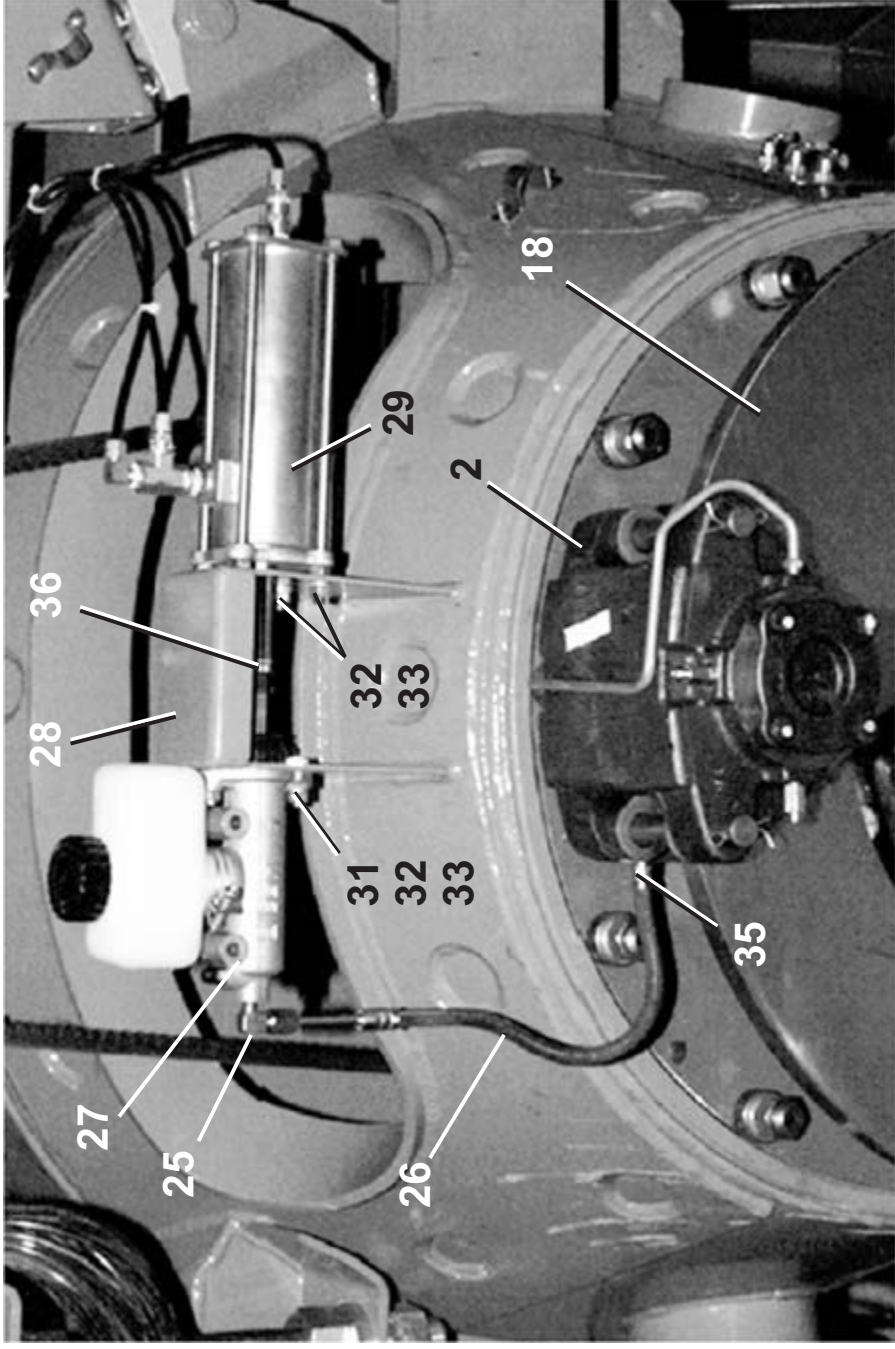
M7E4232C,L,R M9E4232C,L,R M7V4232C,L,R M9V4232C,L,R

BMP940018/2016302B  
(Sheet 1 of 2)



**Pellerin Milnor Corporation**  
P. O. Box 400, Kenner, LA 70063-0400

Litho in U.S.A.





**Pellerin Milnor Corporation**  
P. O. Box 400, Kenner, LA 70063-0400

Litho in U.S.A.

Used In	Item	Part Number	Description	Comments
			ASSEMBLIES-----	
all	A	GBR16001	INSTL=DISC BRAKE 42M7E	INSTALLATION
all	1	X3 65202	COMPONENTS----- MACH=CALIPER MNT PLT MOD2	
all	2	54KC7961	CALIPER HYD FIXMT 12/20 ROTOR	
	2A	54KC7961RS	00Z BRAKE PAD W/SENSOR #B99-13727	REPAIR PART FOR 2
	2B	54KC7961BG	BRAKE HOSE=18"X18"OAL #50612	REPAIR PART FOR 2
	2C	54KC7961BH	02Z BRAKE HOSE #W2261 1/8X18"OAL	REPAIR PART FOR 2
	2D	54KC7961BP	01Z BRAKEFLUID/PISTON KIT #98-1198	REPAIR PART FOR 2
	2E	54KC7961BS	BLEEDERSCREW#10-07721 #2-660	REPAIR PART FOR 2
	2F	54KC7961B0	O-RING 08-11070 BRAKE 2-660	REPAIR PART FOR 2
	2G	54KC7961CT	CROSSOVERTUBEKIT HAY#B98-11700	REPAIR PART FOR 2
	2H	54KC7961H2	01Z BRAKEHOSE #W2511 1/8X32" OAL	REPAIR PART FOR 2
All	3	03 65203	DISC BRAKE PAD DAMPENER 1/8T	2 REQUIRED
all	4	03 65204B	3/16 SPCR=CALIP MNT PLT MOD2	AS REQUIRED
all	5	03 65204	3/8 SPCR=CALIP MNT PLT MOD2	AS REQUIRED
all	6	03 65204A	1/4 SPCR=CALIP MNT PLT MOD2	AS REQUIRED
all	7	03 65204C	10GA SPCR=CALIP MNT PLT MOD2	AS REQUIRED
all	8	03 65204D	14GA SPCR=CALIP MNT PLT MOD2	AS REQUIRED
all	9	15K235A	HXCPCS 3/4-10X2.5 GR 8	
All	10	15U340	LOCKWASH MEDIUM 3/4 ZINCPL	
all	11	15K226C	SKCPCS-5/8-11X3GR8BLK HK	
all	12	15U315	LOKWASHER MEDIUM 5/8 ZINCPL	
all	13	W3 65209	*WLMT=DISC BRAKE COVER MOD2	
all	14	03 65209C	OIL DEFLECTOR DISC BRAKE CVR	
all	15	15K088	HEXCAPSCR 3/8-16NCX7/8 GR 5 ZI	
all	16	15U240	FLATWASHER(USS STD) 3/8" ZNC P	
all	17	15U255	LOCKWASHER MEDIUM 3/8 ZINCPL	
all	18	ABR65001A	DISC BRAKE MOD2=ASSY+BALANCE	
all	19	56AHN18	AN18 BEARING LOCKNUT	
all	20	56AHW18	W18 BEARING LOCKWASHER	
all	21	15E245	SQMACHKEY 7/8X7/8 C1018	
all	22	15P185	TRDCUT-F HXHD 1/4-20UNC2AX3/4	

Used In	Item	Part Number	Description	Comments
all	23	15U180	LOCKWASHER MEDIUM 1/4 ZINCPL	
all	24	15U185	FLATWASHER(USS STD) 1/4" ZNC P	
all	25	52JY0ER004	ELBOWPIPE-90 1/4"MJICXMP#2501-	
all	26	54KC7961BH	BRAKE HOSE #W2261 1/8X18"OAL	
all	27	54KMC1125U	MASTER CYL TILTON 74-1125U	
all	28	W3 65238	*WLMT=MASTER BRAKE CYL BRKT	
all	29	AAC65001	AIRCYL=BRAKE ASSY 6446E6N	
all	30	15G195	HXNUT 5/16-24UNF2B SAE ZINC GR	
all	31	15K065	HEXCAPSCR 5/16-18UNC2AX1 GR5 Z	
all	32	15U210	LOKWASHER MEDIUM 5/16 ZINCPL	
all	33	15G185	HXNUT 5/16-18UNC2B SAE ZINC GR	
all	34	15G205	HXNUT 3/8-16UNC2B ZINC GR2	
all	35	54KC7961B0	O-RING 08-11070 BRAKE 2-660	PART OF ITEM 18
all	36	15K181B	HEXCAPSCR 1/2-13X2 GR8 ZINC	PART OF ITEM 18
All	37	15U317B	FLWASH,1.062ODX.531IDX.115 TH	





# Bearing Assemblies

4





**Pellerin Milnor Corporation**  
P. O. Box 400, Kenner, LA 70063-0400

Litho in U.S.A.

**Parts List—Bearing Assembly & Installation**  
Find the correct assembly first, then find the needed components. The item letters (A, B, C, etc.) assigned to assemblies are referred to in the "Used In" column to identify which components belong to an assembly. The item numbers (1, 2, 3, etc.) assigned to components relate the parts list to the illustration.

Used In	Item	Part Number	Description	Comments
			-----ASSEMBLIES-----	
	A	GBM16002	BEARING INSTALL 4232M7E	INSTALLATION
	B	ABM16002	BEARING ASSY 4232M7E	
			-----COMPONENTS-----	
all	1	Y3 16022A	MAIN SHAFT=MACHINED 42M7E	
all	2	24S131FN	SEAL 6.89-7.28X6.37X.31V180A-N	
all	3	Y3 25106	V-SEAL COVER 52I72 WE	
all	4	03 25106G	V-SEALCOVER GASKET (N-8051)	
all	5	15K225	HXCPSR 5/8-11X2+1/2	
all	6	15U315	LOKWASHER MEDIUM 5/8 ZINCPL	
all	6	20C008C	THDLOCK-RMUBL-250CC LT#242-41	
all	7	56AHW30	W30 BEARING LOCKWASHER	
all	8	56AHN30	AN30 BEARING LOCKNUT	
all	9	24S127	SEAL5.25X6.50X.625 JM#7112LUP	
all	10	X3 25107S	MACH=FRBRGCAP=RR LEAKOFF/AIR	
all	11	60C186	ORING 12.0IDX1/8CS BUNA70 #278	
all	12	X3 25106S	MACH FRNTBRGH=RR LEAKOFF/AIR	
all	13	X5 20051A	SLEEVE=SEAL	
all	14	24S130	SEAL 7X8X.625 JM#6862 NITRILE	
all	15	56S22330T	SPHEROLBRG 22330LBK-C3-W33-C40	
all	16	03 25415	GREASE SHIELD FRONTBEAR ZNPL	
all	17	5SL0CBEA	NPTLNB 90DEG 1/8 BRASS 125#	
all	18	53A005B	BODYMALCON1/4X1/8COMP #B68A-4A	
all	19	5N0C03AG42	NPT NIP 1/8X3 TBE GALSTL SK40	
all	20	5SCC0CBE	NPT COUP 1/8 BRASS 125# 103A-A	
all	21	5SP0CFESSV	NPTPLUG1/8SQSLDBLKSTL LVENT125	
all	22	51P013	PLUG HXCNTRSUNK 1/4"BRASS	
all	23	5N0E02KG42	NPT NIP 1/4X2.5 TBEGALSTL SK40	
all	24	5SCC0EBE	NPT COUP 1/4 BRASS 125# W/HEX	
all	25	5SP0CFESSV	NPTPLUG1/8SQSLDBLKSTL LVENT125	
all	26	54M029	RELIEFFIT 1/8STR ALEMITE 47200	
all	27	15K226F	HXCAPSCR 5/8-11UNC2AX3 GR5 ZIN	
all	101	60C192	ORING 15IDX1/4CS BUNA70 #459	
all	102	15U250	SEALWASHER 3/8" S/S PARKER #60	
all	103	15K100	HEXCAPSCR 3/8-16X1+1/4 SS18-8	
all	104	03 25211	LOCKSTRIP-(S/S)=BRGHSG=SEAL	
all	105	02 02293	DOOR HANDLE NUT GASKET	
all	106	Y3 25233	MACH RING=BEARHSG STATICSEAL	
all	107	03 25237	GASKET=SEAL MTG RING	
All	108	15K236C	HXCPSR-1-8X2.75 GR8ZC	
all	109	15U393	FLTWASH 1"ZNC DICR	

Used In	Item	Part Number	Description	Comments
all	110	20C008C	THDLOCK-RMUBL-250CC LT#242-41	
all	111	60C190	ORING 13.9IDX1/4CS BUNA70#457	
all	112	ABM16002	BEARING ASSY 4232M7E	
all	113	24S127	SEAL5.25X6.50X.625 JM#7112LUP	
all	114	15K083	HXCAPSCR 3/8-16 UNC2AX1/2 GR5	
all	115	15U255	LOCKWASHER MEDIUM 3/8 ZINCPL	
all	116	Y3 16031A	MACH=BRG HOUSING MNT PLT	
all	117	X3 25108B	REAR BEARING HSEING 4232M7E	
all	118	56AHW20	W20 BEARING LOCKWASHER	
All	119	56AHN20	AN20 BEARING LOCKNUT	
all	120	24S112	SEAL 3.75X4.75X.500 CS/BUNA	
all	121	03 16339	REAR BRG SEALHLDR EXT 42M7E	
all	122	03 16339A	GASKET= REAR BRG HSE SLHLDR	
all	123	54M029	RELIEFFIT 1/8STR ALEMITE 47200	
all	124	15K235A	HXCPSR 3/4-10X2.5 GR 8	
all	125	15U319A	F-WASH=.753IDX13/8ODX1/2"THK	
all	126	15U340	LOCKWASH MEDIUM 3/4 ZINCPL	
all	127	15G240A	HEXNUT 3/4-10UNC2B SAE GR8 ZIN	
all	128	03 16337	REAR BRG SEALHOLDER 42M7E	
all	129	56S22322T	SPHEROLBRG NTN#22322BL1KD1C3	
all	130	53A059A	NUT 1/4"BR.HOLYOKE AND #61A-4	
all	131	53A500	SLEEVE DELRIN 1/4"OD#60PT-4	
all	132	53A501	TUBE INSERT .163"OD #63PT-4-40	
all	133	5N0C03AG42	NPT NIP 1/8X3 TBE GALSTL SK40	
all	134	5SL0CBEA	NPTLNB 90DEG 1/8 BRASS 125#	
All	135	53A005B	BODYMALCON1/4X1/8COMP #B68A-4A	
all	137	53A007B	BODYFEMCON.25X.25COMP#B66A-4B	
all	138	60E004TC	TUBING NYL(NAT)1/4"ODX.17ID	
all	139	01 10025Z	NPLT:BEARING&SEAL LUB-42" & 36"	
All	140	5SB0E0CBEO	NPTHEXBUSH 1/4X1/8 BRASS 125#	
all	141	54M020	GREASEFIT 30DEG 1611-B ALEMITE	
all	142	51P033	PLUG CAP 3/4"NPT TAPER #31	
all	143	17E010	DOWEL PIN 1/2"X 1"(.0002) STD	

**Cylinders and Cotton Mod Piping**

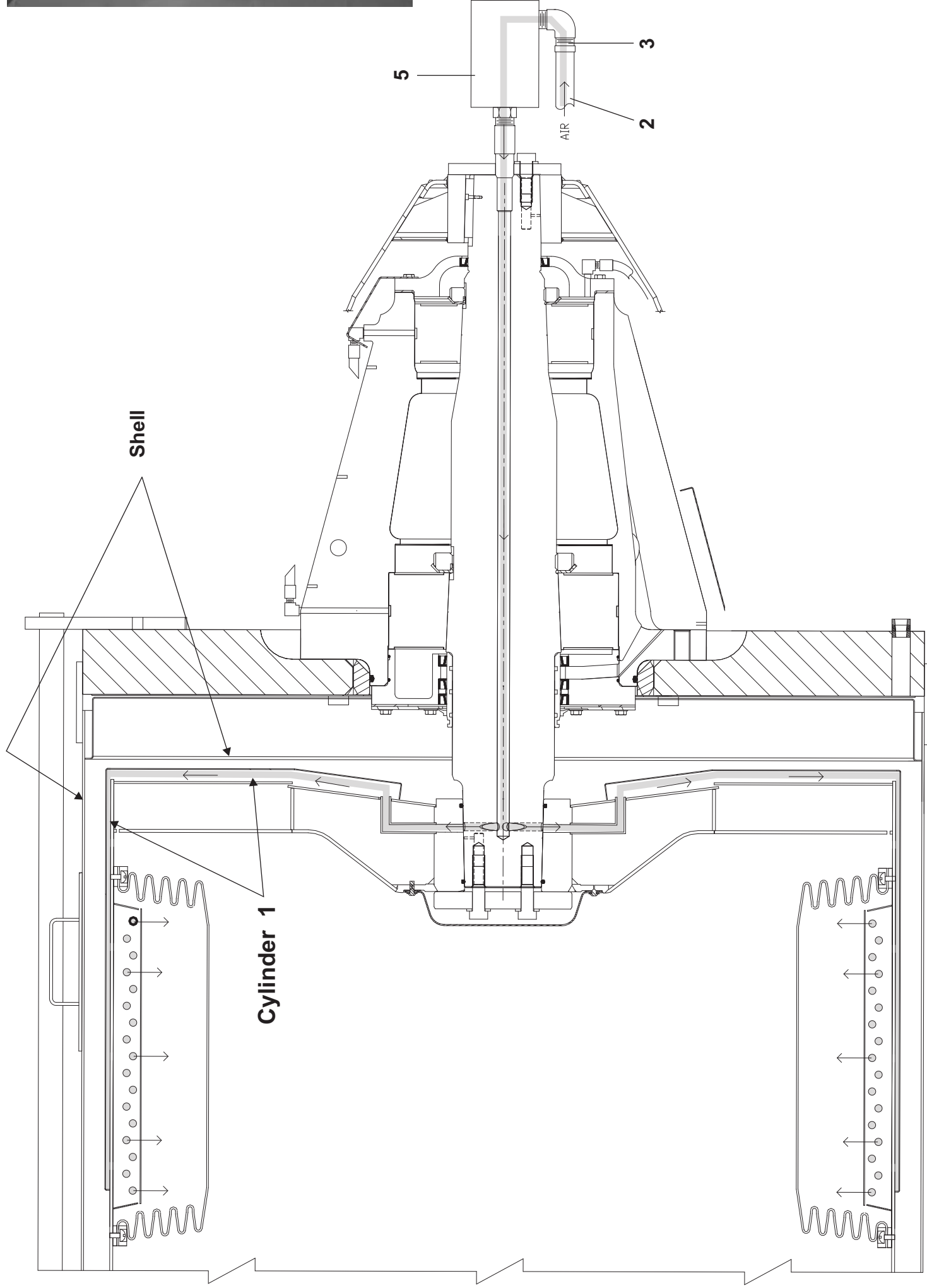
M9V4232C/L/R, MXV4232C/L/R, MMV4232C/L/R M9S4232C/L/R, MXS4232C/L/R, MMS4232C/L/R M9V4840C/L/R, M9T4840C/36C

BMP050031/2018444B  
(1/4)

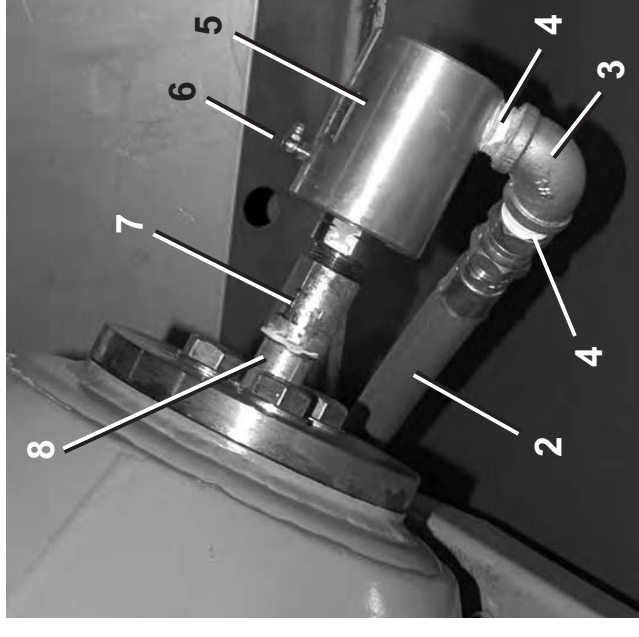


Pellerin Milnor Corporation  
P. O. Box 400, Kenner, LA 70063-0400

Litho in U.S.A.



Inflatable rib assembly (See BMP110048.)



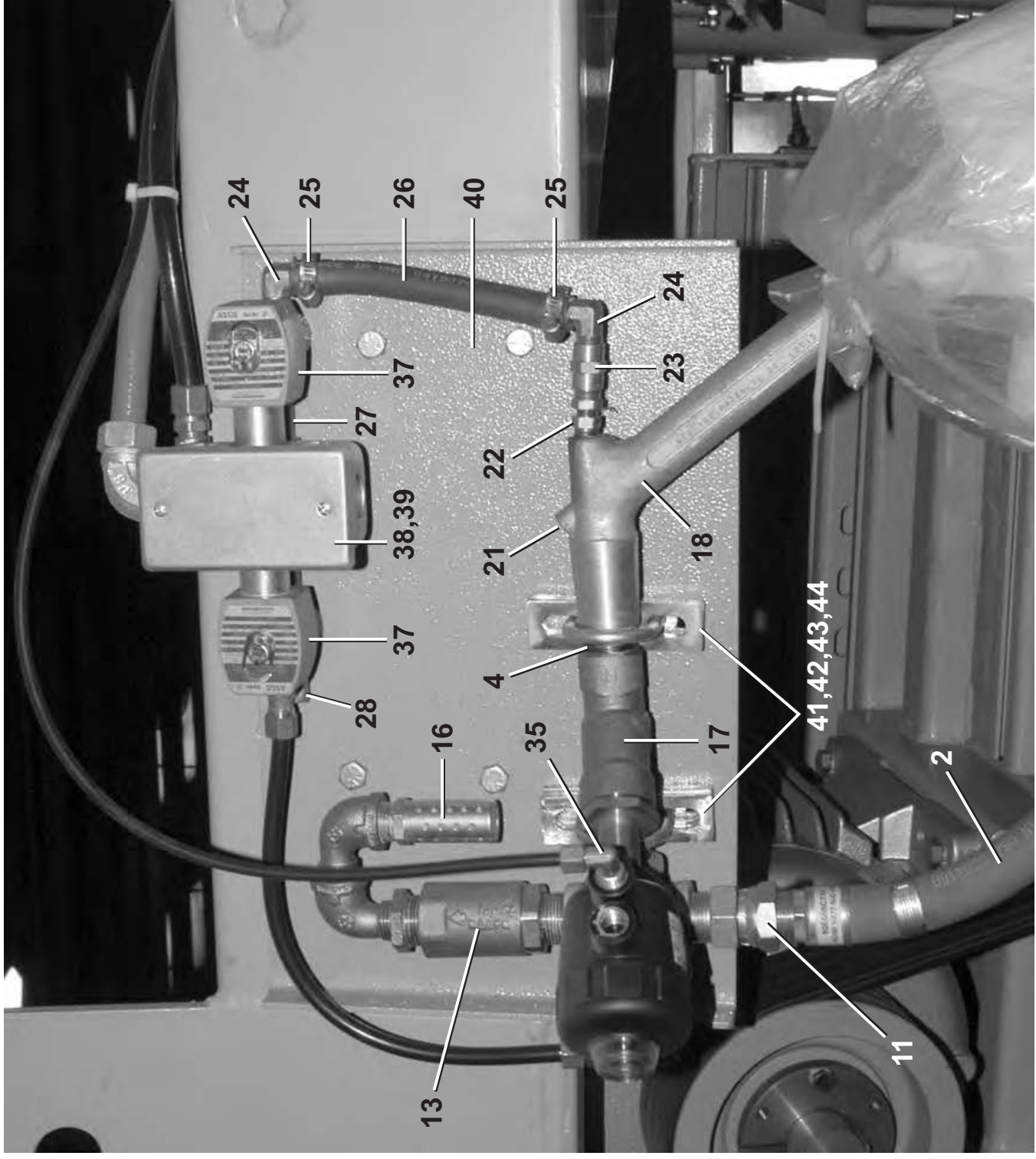
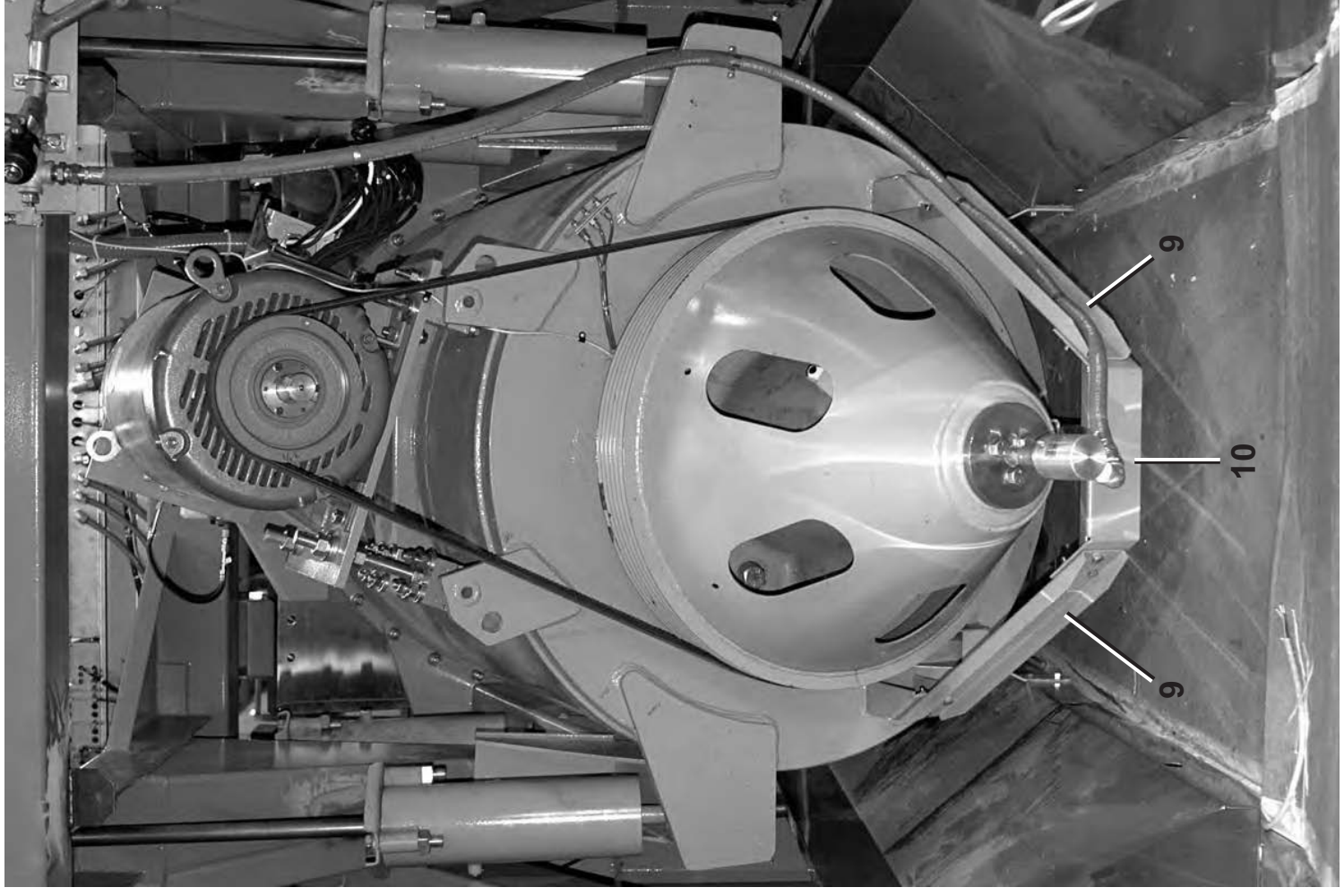
Air through bearing to cylinder ribs

**Cylinders and Cotton Mod Piping**  
**M9V4232C/L/R, MXV4232C/L/R, MMV4232C/L/R M9S4232C/L/R, MMS4232C/L/R, MXS4232C/L/R, M9V4840C/L/R, M9T4840C/36C**

BMP050031/2018444B  
 (2 / 4)

**MILNOR**  
 Pellerin Milnor Corporation  
 P. O. Box 400, Kenner, LA 70063-0400

Litho in U.S.A.



Cotton Mod Piping

# Cylinders and Cotton Mod Piping

M9V4232C/L/R, MXV4232C/L/R, MMV4232C/L/R

M9S4232C/L/R, MXS4232C/L/R, MMS4232C/L/R

M9V4840C/L/R, M9T4840C/36C

BMP050031/2018444B  
(3 / 4)

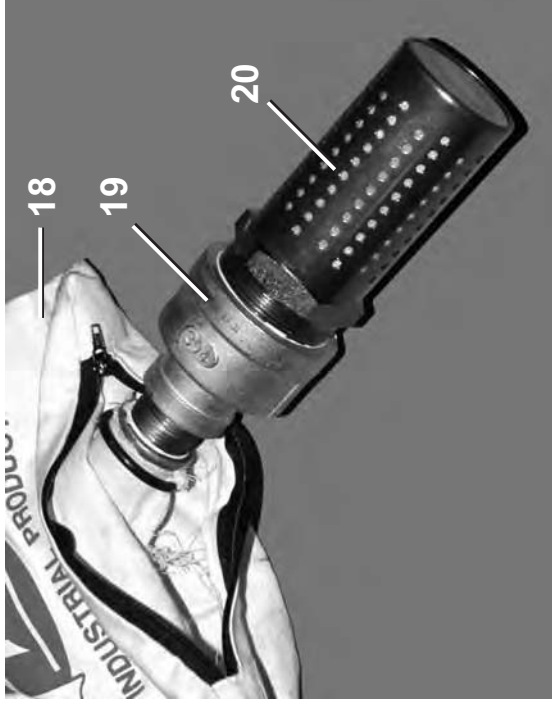


Pellerin Milnor Corporation  
P. O. Box 400, Kenner, LA 70063-0400

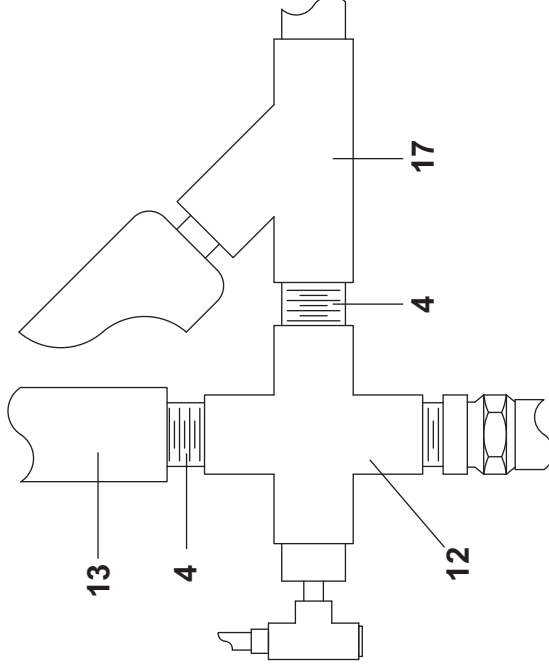
Litho in U.S.A.

**Parts List—Cylinders and Cotton Mod Piping**  
Find the correct assembly first, then find the needed components. The item letters (A, B, C, etc.) assigned to assemblies are referred to in the "Used In" column to identify which components belong to an assembly. The item numbers (1, 2, 3, etc.) assigned to components relate the parts list to the illustration.

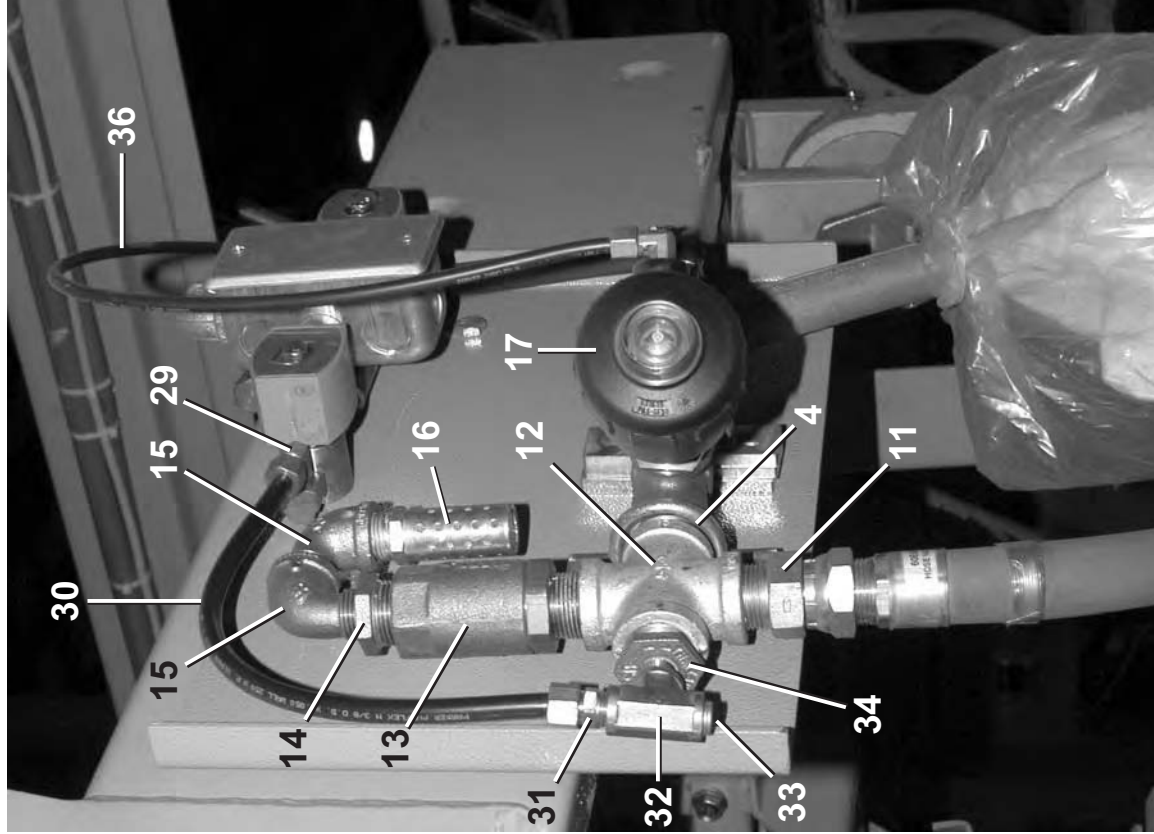
Used In	Item	Part Number	Description	Comments
			-----ASSEMBLIES-----	
	A	ACM16001	COTTON MOD PIPING ASSY	M9V4232, MXV4232 M9S4232, MXS4232 MMV4232, MMS4232
	B	ACM17002	CYLINDER BELT LINER ASSY-4840M	M9V4840
			-----COMPONENTS-----	
all	1	ACA42CTM9E	7GA CYLINDER COTTON MOD 4232M9E	M9E4232 COT CYLINDER
all	1	ACA4232C01	7GA CYLINDER COT MOD, 4232M9/MX	M9S/MXS4232 COT CYL
all	1	ACA42TFMXV	7GA CYLINDER TEFLON 4232MXV COT	MXV4232 COT TEFLON
all	1	ACA42TFMMV	CYLINDER COT TEFLON 4232MMV	MMV4232 COT CYLINDER
all	1	ACA4232MV1	7GA CYLINDER TEF COT MOD, 4232MMS	MMS4232 COT TEFLON
all	1	ACA4840COT	CYLINDER COTTON 4840M	M9V4840 COT CYLINDER
A	2	60E086C77K	WATERHOSE=.75"X77.5" LG + 2 EN	
B	2	60E086C106	HOSE ASSY=.3/4"X106"LG+ENDS	
all	3	5SL0PNFA	NPTLVB 90DEG 3/4 GALMAL 150#	
all	4	5N0PCLSG42	NPT NIP 3/4XCLS TBE GALSTL S40	
all	5	24S075	ROTUNION 3/4" DEUBLIN250094020	
all	6	54M021	GRSFIT 1/8PIPE X 1/4STR 1607-B	
all	7	5SCC0PNF	NPT COUP 3/4 GALMAL 150#	
all	8	5N0P03AG42	NPT NIP 3/4X3 TBE GALSTL SK40	
B	9	03 17038	4840M AIR HOSE BAR	
B	10	03 17039	4840M AIR SUPPORT BRKT	
all	11	51X019	UNIONSTRADT 3/4"#0107-12-12	
all	12	5SX0PNF	NPT CROSS 3/4" GALMAL 150#	
all	13	96D046	CK VAL 3/4" #600-Z3 W/S/S DISH	
all	14	5SB0POKBEO	NPTHEXBUSH 3/4X1/2 BRASS 125#	
all	15	5SLOKBEC	NPTLVB 90DEGSTRT 1/2 BRASS 125	
all	16	27A005B	MUFFLER 1/2" BANTAM B48	
all	17	96D0009E	3/4"NPTBRZ N/C STEAMVAL ANGBOD	
all	18	X3 16201T	AIR VAC #80-201 TAPPED ENDS	
all	19	5SR2A1ASF	NPT RED 2X1 SS304 150#	
all	20	27A005C	MUFFLER 2" BANTAM B168	
all	21	51T020	STRAINER 1/4 AND.BRASS#234S-L	



Vacuum and muffler



Detail: Cross tee



Cotton Mod Piping



**Pellerin Milnor Corporation**  
P. O. Box 400, Kenner, LA 70063-0400

Litho in U.S.A.

**Parts List—Cylinders and Cotton Mod Piping**

Find the correct assembly first, then find the needed components. The item letters (A, B, C, etc.) assigned to assemblies are referred to in the "Used In" column to identify which components belong to an assembly. The item numbers (1, 2, 3, etc.) assigned to components relate the parts list to the illustration.

Used In	Item	Part Number	Description	Comments
all	22	5SB0E0CBEO	NPTHEXBUSH 1/4X1/8 BRASS 125#	
all	23	5SCC0EBE	NPT COUP 1/4 BRASS 125# W/HEX	
all	24	51E504EB	ELB HOSESTEM 3/8HX1/4NPT BRASS	
all	25	27A040	HOSECLAMP 7/16-25/32SS W/SCREW	
all	26	60E077	HOSE AIR-WATER 3/8"#7134-381	
all	27	5N0E02ABE2	NPT NIP 1/4X2TBE BRASS 125#	
all	28	5SL0EBEC	NPTELB 90DEG STRT 1/4 BRASS125	
all	29	53A043G	EL90 3/8X1/4COMP.AND#69A-6B	
all	30	60E005B	TUBING NYL.3/8"OD X.275"ID	
all	31	53A043A	BULKHDUNION 3/8"COMP.BODY ONLY	
all	32	5S0EBEA0G	NPT TEE 1/4X1/4X3/8 BRASS 125#	
all	33	51P013	PLUG HXCNTRSUNK 1/4"BRASS	
all	34	5SB0P0EBEO	HEXBUSH 3/4X1/4 BRASS 125#	
all	35	53A031B	BODY-EL90MALE.25X1/8 #269C-42B	
all	36	60E004TE	1/4"OD X.170"ID NYL(BLK)TUBING	
all	37	96TBC2BA37	1/4" N/C 2WAY 120V50/60C VALVE	
all	38	12H050D	HANDYBOX 4X2+1/8 X 2+1/8	
all	39	12H095	HANDY BOX COVER 4+2+1/8	
all	40	03 16353	AIR SUCT CONTROL BRKT	
all	41	27A031B	UBOLT 1"PIPE 5/16-18X2+15/16LG	
all	42	15U210	LOKWASHER MEDIUM 5/16 ZINCPL	
all	43	15G185	HXNUT 5/16-18UNC2B SAE ZINC GR	
all	44	02 10539S	SPACER PIPE DAS	
:				

# Inflatable Rib Assembly

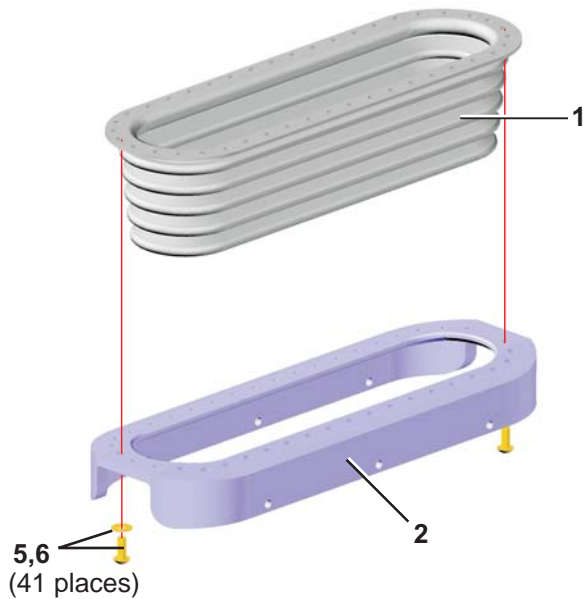
**MXS4232, M9V4232, M9V4840, M9T4840**

BMP110048/2018444A  
(Sheet 1 of 2)



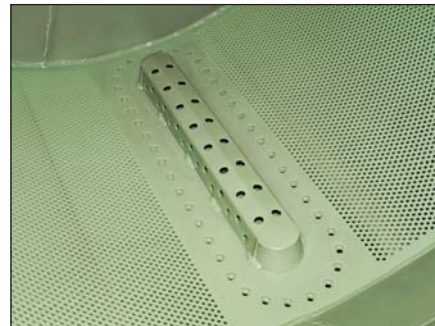
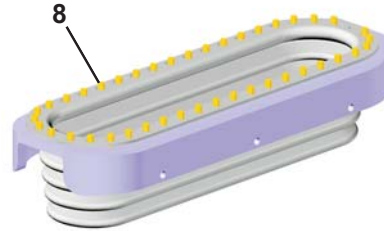
Pellerin Milnor Corporation  
P. O. Box 400, Kenner, LA 70063-0400

Litho in U.S.A.

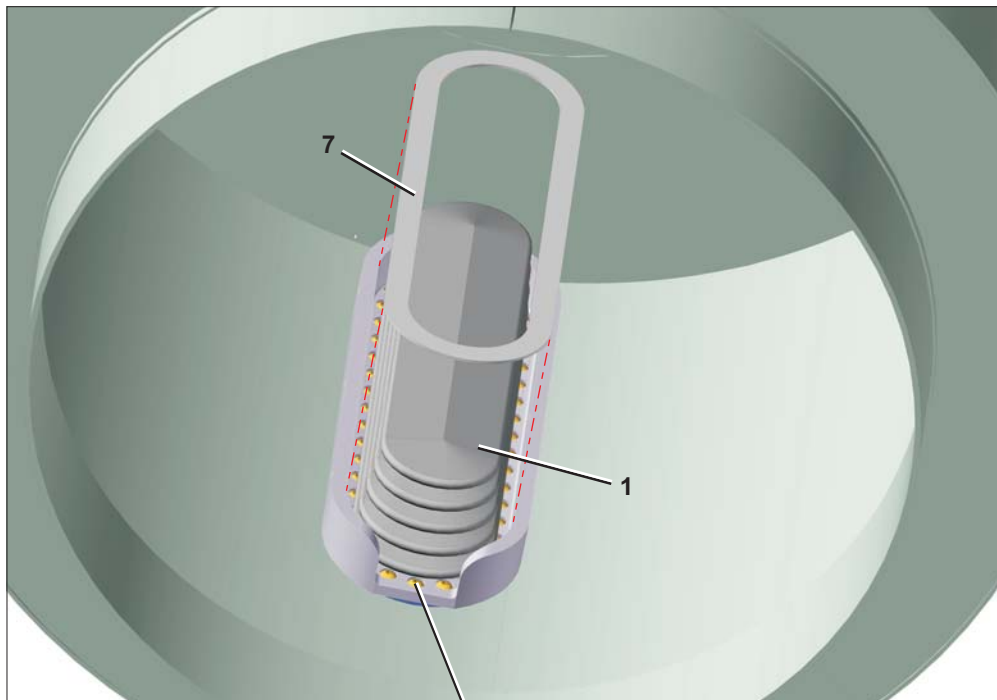


Pre-assemble the inflatable ribs, uhmw trays, and the gaskets (2 assemblies). Insert all 82 bolts (item 5).

Apply thread locker, item 8, to the ends of the bolts.



Cylinder with Cotton Modifications



Install the inflatable rib assemblies to the cylinder. Tighten the bolts to 10 ft-lbs of torque. Cover the bolts with EPDM gasket (item 7) and position it under the inflatable rib (item 1).



# Inflatable Rib Assembly

## MXS4232, M9V4232, M9V4840, M9T4840

BMP110048/2018444A  
(Sheet 2 of 2)



Pellerin Milnor Corporation  
P. O. Box 400, Kenner, LA 70063-0400

Litho in U.S.A.

### Parts List—Inflatable Rib Assembly

Find the correct assembly first, then find the needed components. The item letters (A, B, C, etc.) assigned to assemblies are referred to in the "Used In" column to identify which components belong to an assembly. The item numbers (1, 2, 3, etc.) assigned to components relate the parts list to the illustration.

Used In	Item	Part Number	Description	Comments
-----ASSEMBLIES-----				
	A	KQM-E00202	M7E 42EXT=INFLAT RIBS .165THK	AVAILABLE KIT INCLUDES ALL PARTS LISTED BELOW, ALL 4232 & 4840 EXTRACTORS
-----COMPONENTS-----				
all	1	03 16014E	EXTRACTOR INFLATABLE RIB-.25 FLANGE	
all	2	03 16494B	RIB BOLT DOWN 4"W SLOT-UHMW	
all	5	15K091F	BUTSOKCAPSCR 3/8-16X7/8"LG BRASS E=	
all	6	15U242S	FLATWASH .453IDX.750ODX.032SS0	
all	7	03 16488C	RIB BOLTDOWN EPDM GASKET	
all	8	20C007G	THDLOCKSEAL LCT24231 RMUBL50CC	



# Frame, Pivots and Suspension

5

# Installation of Pivot Ball Bushing

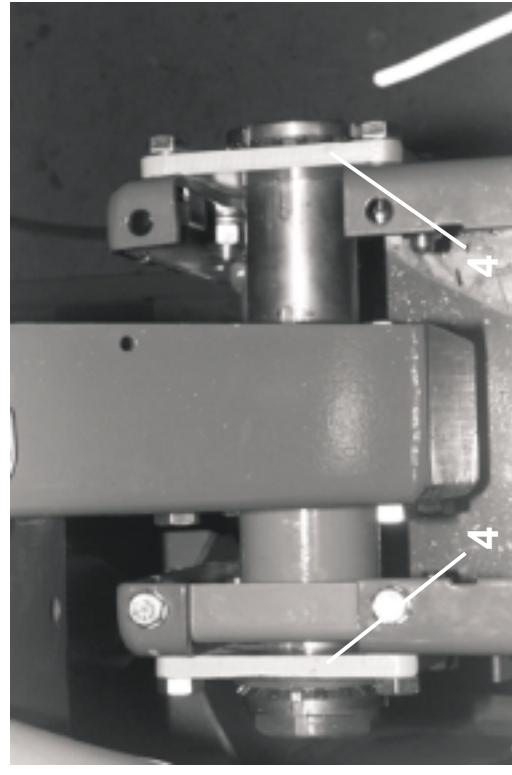
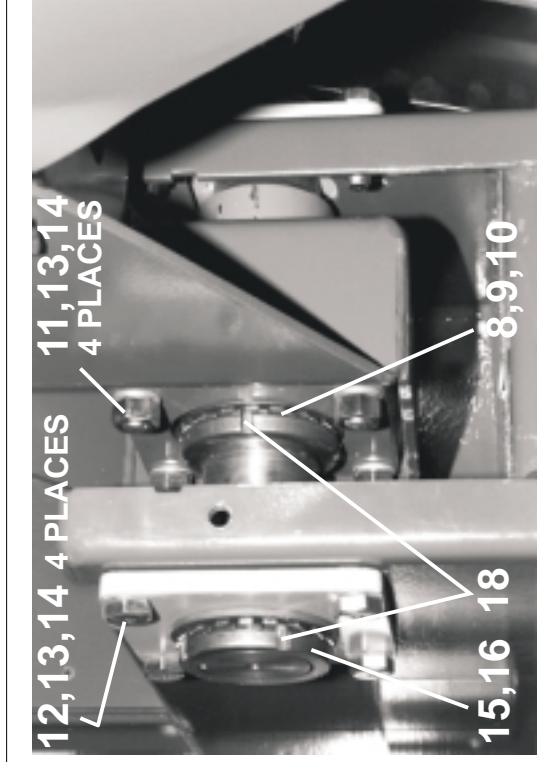
42032M7/M9 64040,64050E6N 64046E6N/J6N 72046E5N/J5N 72058J2N/J5N 72075J2N

BMP930020/2001204V  
(Sheet 1 of 2)



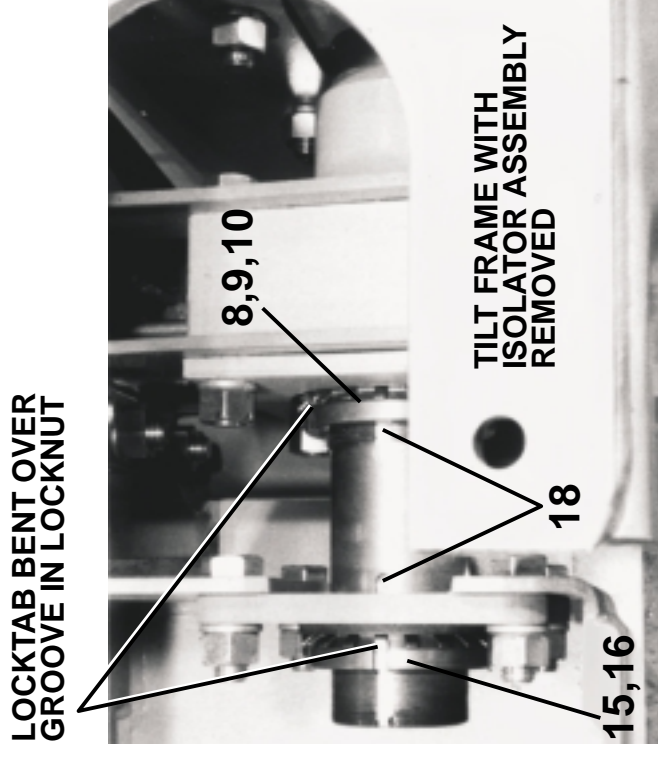
Pellerin Milnor Corporation  
P. O. Box 400, Kenner, LA 70063-0400

Litho in U.S.A.

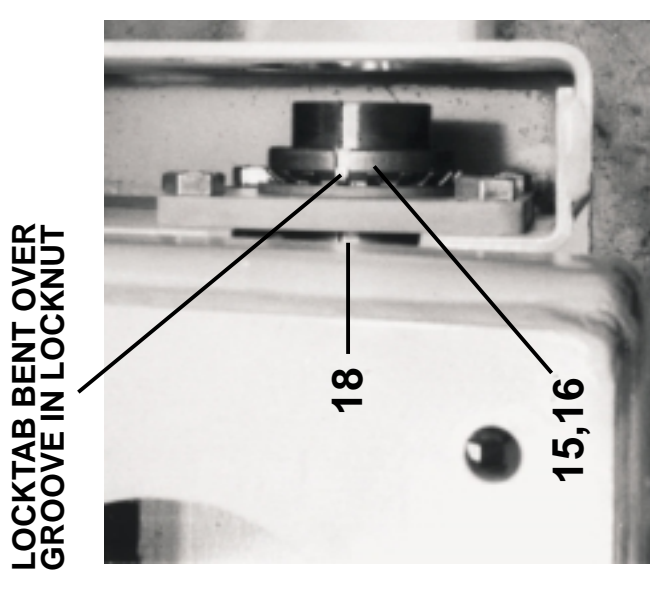


Note: These two views are of the 42032M7E Pivot Installation-Right Side

Top View of Right Pivot

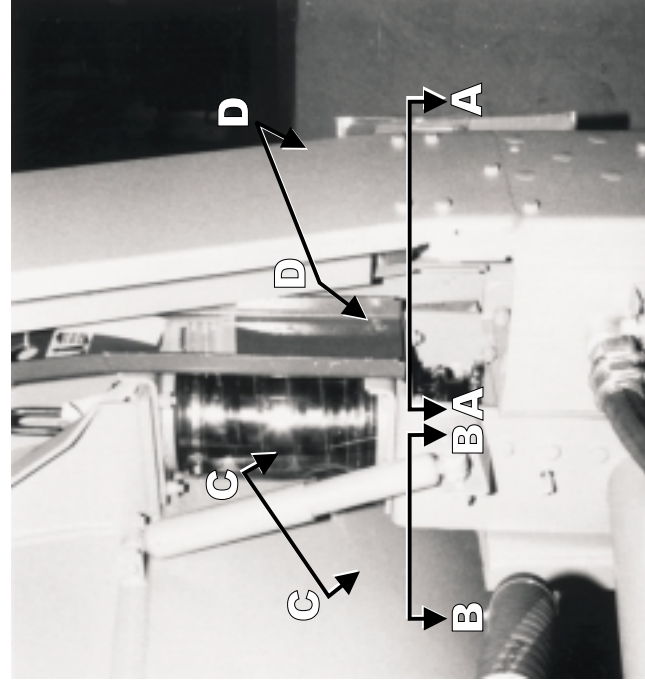


View A-A

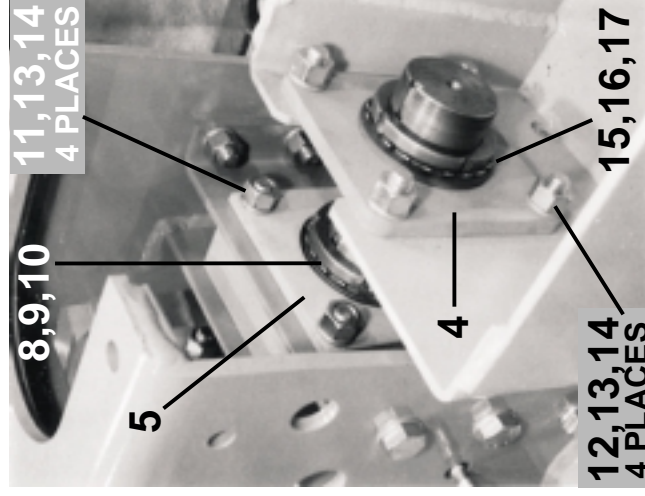


View B-B

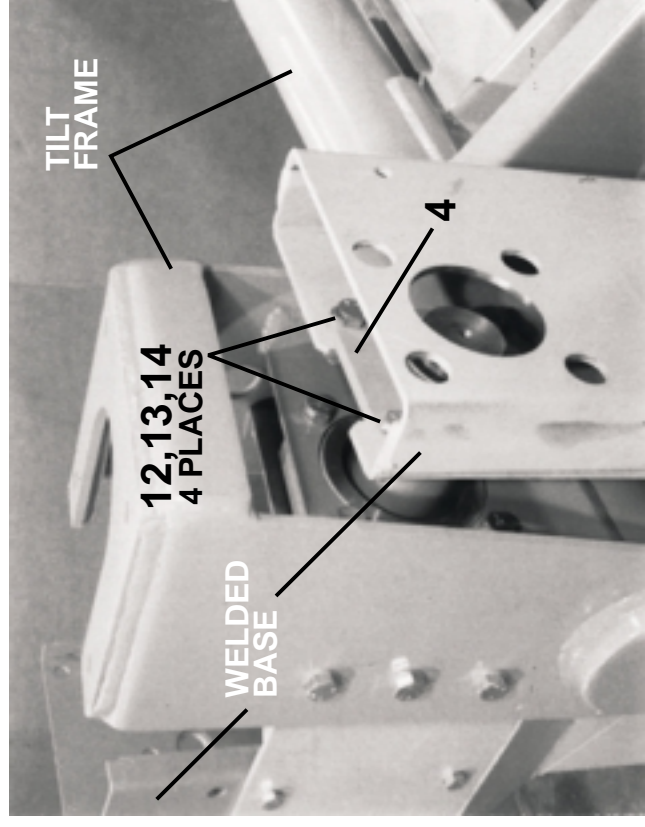
SEE BMP930026



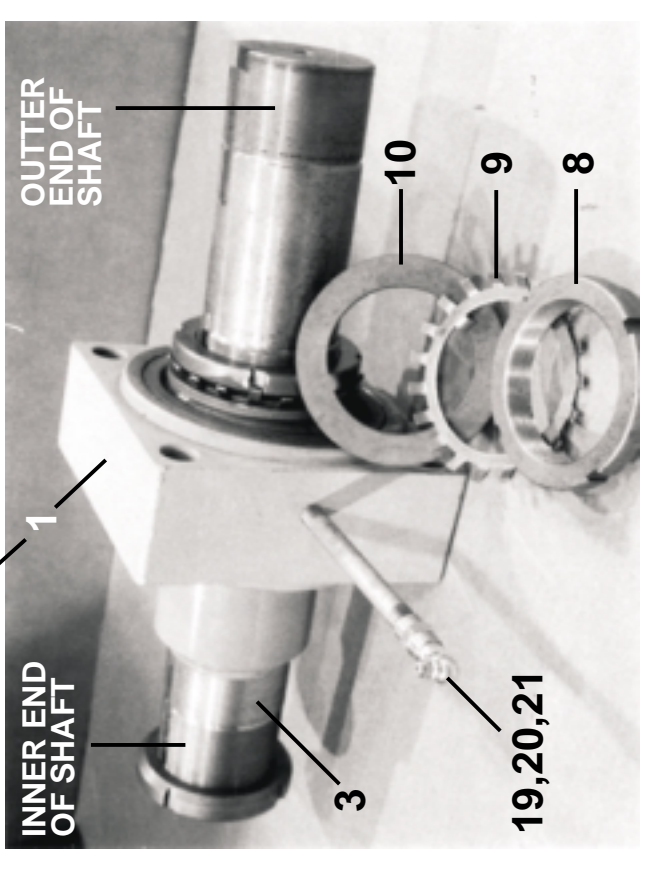
Overview Pivot Installation 64046E6N-Left Side



View C-C



View D-D



Ball Bushing and Shaft



Pellerin Milnor Corporation  
P. O. Box 400, Kenner, LA 70063-0400

Litho in U.S.A.

**Parts List—Pivot Ball Bushing**

Find the correct assembly first, then find the needed components. The item letters (A, B, C, etc.) assigned to assemblies are referred to in the "Used In" column to identify which components belong to an assembly. The item numbers (1, 2, 3, etc.) assigned to components relate the parts list to the illustration.

Used In	Item	Part Number	Description	Comments
			-----ASSEMBLIES-----	
	A	GBM16003	93491B INSTL=BAL BUSH PIVOT M7E/E6N	
			-----COMPONENTS-----	
all	1	ABM16003	93442B ASSY=BAL BUSH PIV 42M7E64E6N	
all	3	X3 65150	94277C SHAFT=3" BALL BUSH PIVOT	
all	4	X3 65153	93023B MNT PLT=3" BALL BUSH PIVOT	
all	5	03 65152	93491B LOCK PLT=3" BALL BUSH PIVOT	
all	8	56AHN14	N14 BEARING LOCKNUT	
all	9	56AHW14	W14 BEARING LOCKWASHER	
all	10	56ATW14	TONGUE WASH TIM K91514 FOR N14	
all	11	15K227A	HXCAPSCR 5/8-11X4.5 Gr8 ZINC	
all	12	15K214E	HXCAPSCR 5/8-11UNC2AX1.5 GR5 ZNC/CD	
all	13	15U315	LOKWASHER MEDIUM 5/8 ZINCPL	
all	14	15G238B	HEXFINNUT 5/8-11UNC2 Gr8 ZINC	
all	15	56AHN13	N13 BEARING LOCKNUT	
all	16	56AHW13	W13 BEARING LOCKWASHER	
all	18	15E212	STDSQMACHKEY 5/16X2+1/2 C1018	
all	19	5N0C04AG42	NPT NIP 1/8X4 TBE GALSTL SK40	
all	20	5SCC0CBE	NPT COUP 1/8 BRASS 125# 103A-A	
all	21	54M023	GRSFIT 45DEG ALEMITE 1688-B	

# Ball Bushing

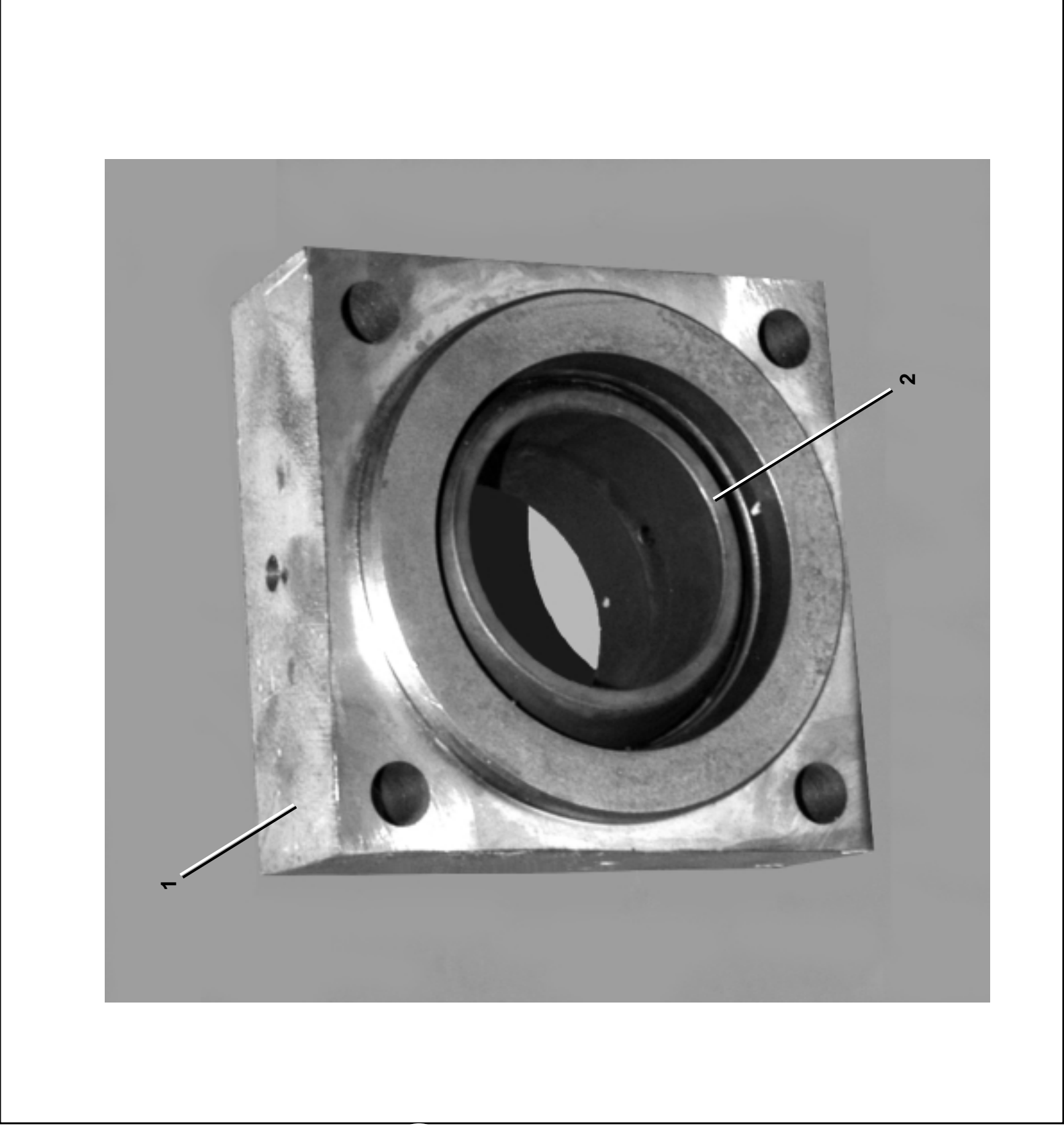
64046E6N/J6N, 72046E5N/J5N, 72058J2N/J5N, 42032M7E, M7V4840C, M7V4836C

BMP930026/2005105V  
(Sheet 1 of 1)



Pellerin Milnor Corporation  
P. O. Box 400, Kenner, LA 70063-0400

Litho in U.S.A.



**Parts List—Assembly Ball Bushing**  
Find the correct assembly first, then find the needed components. The item letters (A, B, C, etc.) assigned to assemblies are referred to in the "Used In" column to identify which components belong to an assembly. The item numbers (1, 2, 3, etc.) assigned to components relate the parts list to the illustration.

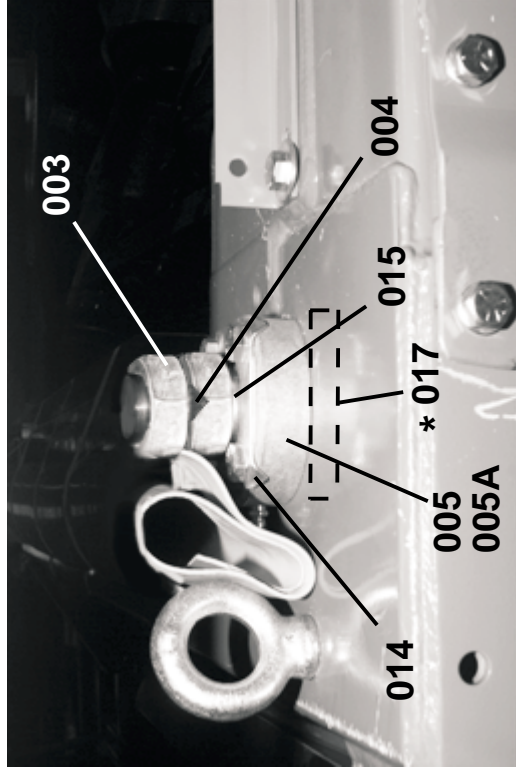
Used In	Item	Part Number	Description	Comments
	A	ABM16003	ASSEMBLIES ASSY=BAL BUSH PIV 42M7E64E6N	
	1	X3 65151	COMPONENTS MNT BLOCK=3" BALL BUSH PIVOT	
all	2	54A707	BALL BUSHING 3" RBC# B48-L	



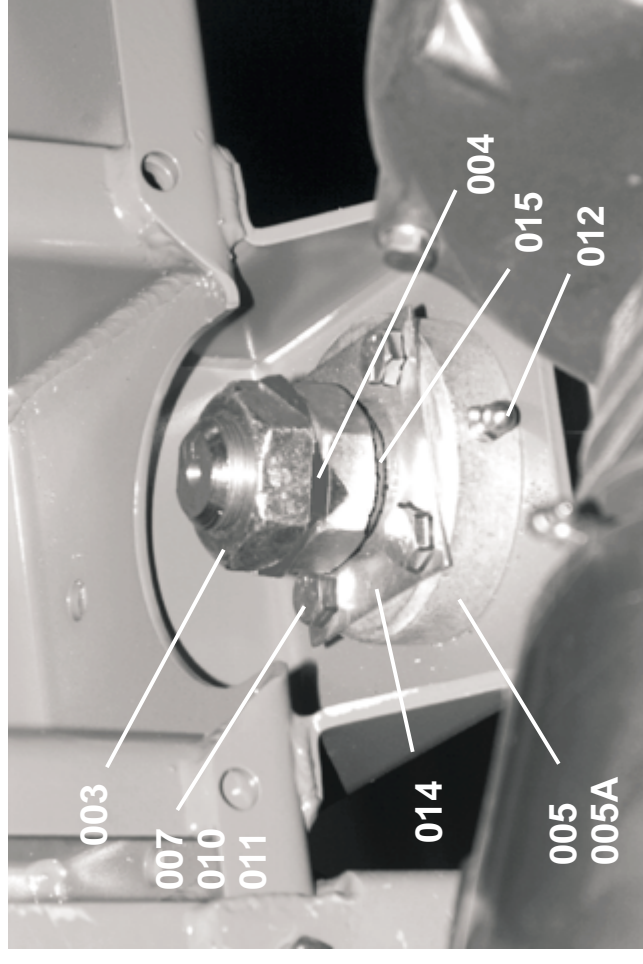
Pellerin Milnor Corporation  
 P. O. Box 400, Kenner, LA 70063-0400

Litho in U.S.A.

**FRONT HYDRO-CUSHION TOP MOUNTS**

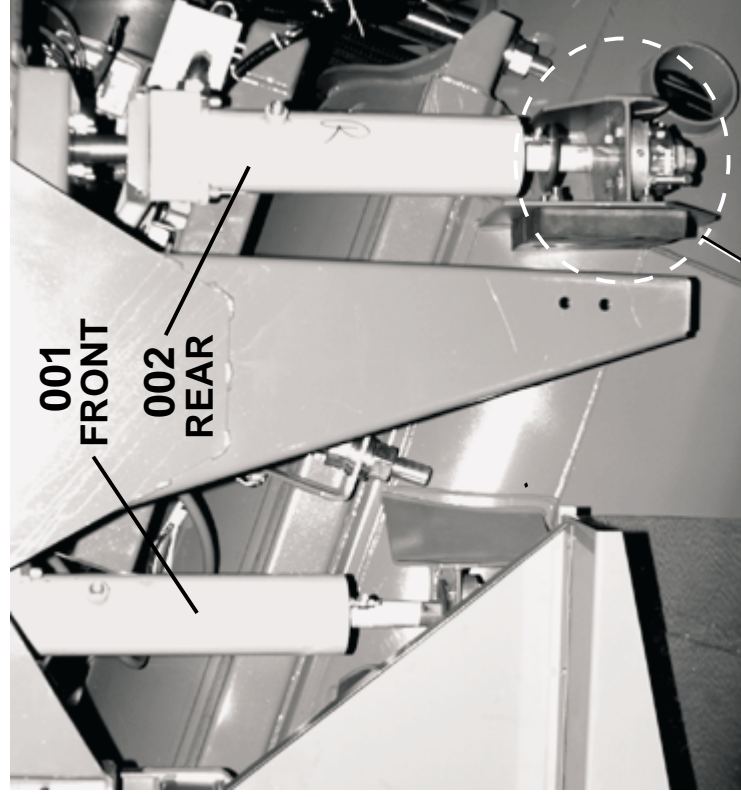
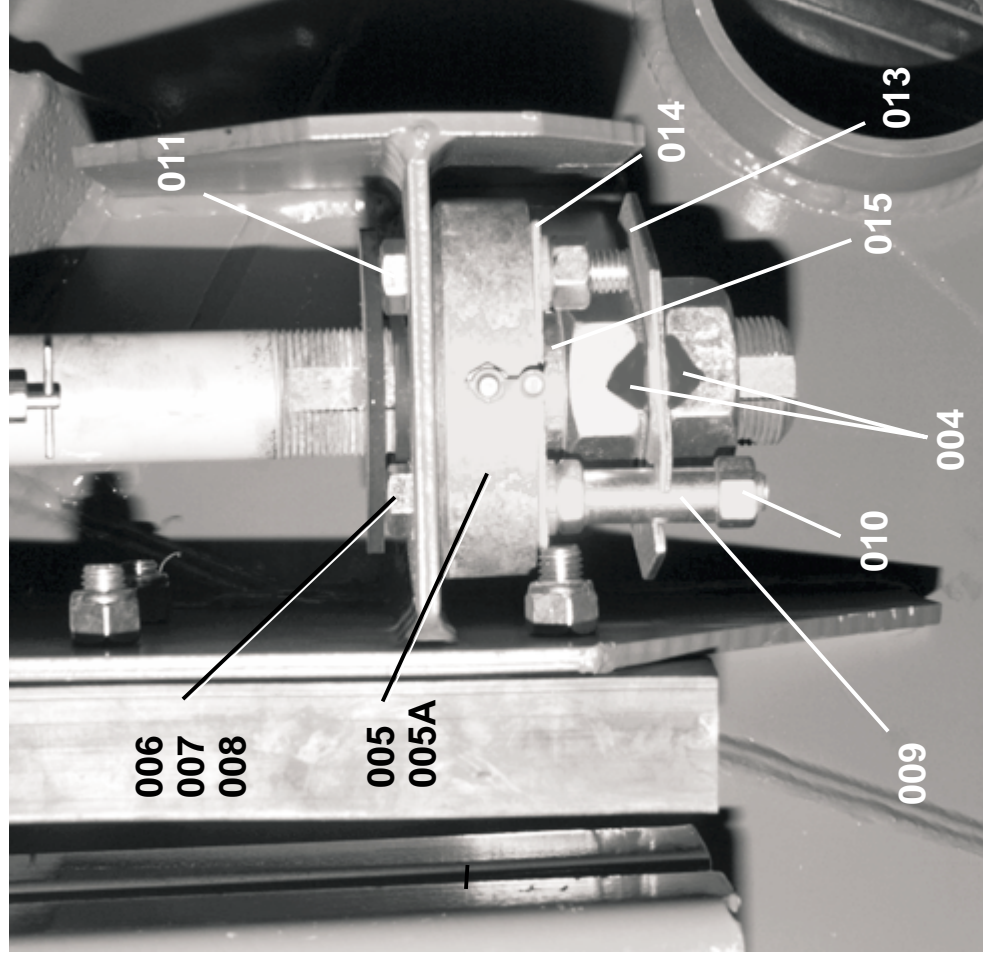


**REAR HYDRO-CUSHION TOP MOUNTS**



\* ITEM 017 IS A STIFFENER THAT MOUNTS ON THE INSIDE OF THE INNER HOUSE FRAME.

BOTTOM MOUNT APPLIES TO BOTH FRONT AND REAR HYDRO-CUSHIONS



SEE DETAIL-A

DETAIL-A



Pellerin Milnor Corporation  
P. O. Box 400, Kenner, LA 70063-0400

Litho in U.S.A.

**Parts List—Hydrocushion Cylinder Installation**

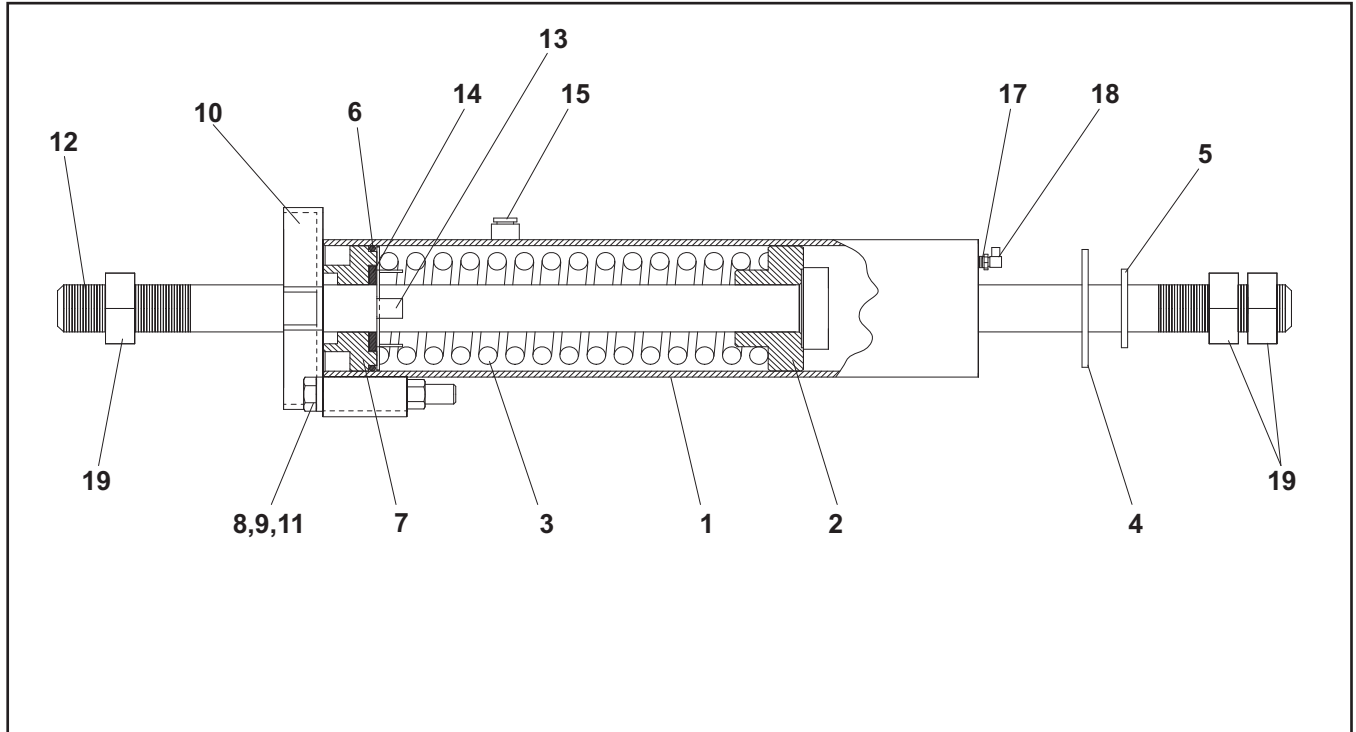
Find the correct assembly first, then find the needed components. The item letters (A, B, C, etc.) assigned to assemblies are referred to in the "Used In" column to identify which components belong to an assembly. The item numbers (1, 2, 3, etc.) assigned to components relate the parts list to the illustration.

Used In	Item	Part Number	Description	Comments
-----ASSEMBLIES-----				
	A	GHC16000	HYDRCUSH CYL INSTL 42M7E	INSTALLATION
-----COMPONENTS-----				
all	1	AHC16000F	HYDRCUSH CYL ASSY FRNT 42M7E	
all	2	AHC16000B	HYDRCUSH CYL ASSY REAR 42M7E	
all	3	15G268	HXFINJAMNUT 1+1/2-12UNF2B ZINC	
all	4	02 18256	LOKWASH-TONGUE 8/WEH ZINC	
all	5	X3 06252	RETAINER-BALBUSH=4/72WEDU	
all	5	54A705	BALBUSH 1.5 SKF#GEZ108ESAVE467	
all	6	15D119	HXTAPSCR 1/2-13X4 GR5 ZNC FULL	
all	7	15U300	LOKWASHER REGULAR 1/2 ZINC PLT	
all	8	15G231	HXFINJAMNUT 1/2-13UNC2B ZINC G	
all	9	27B250	SPCRROLL.5ID1.5L.062T STLZNC	
all	10	15G230	HXNUT 1/2-13UNC2B SAE ZINC GR2	
all	11	15K191	HXCAPSCR 1/2-13UNC2AX2.5 GR5 Z	
all	12	54M025	HYDFIT 1/8"-90 ALEMITE 1613-B	
all	13	02 18795A	WASH-TIMING=HYDRO CYL 45DEG	
all	14	02 18534	HOLDPLATE= BALLBUSH ZNC/CAD	
all	15	02 18571A	PISTON ROD WASHER-.25"TK	
all	17	03 16224	INNR HSE FRNT X CHNL STFR	



# Hydrocushion Cylinders

M9V4232C,L,R MXS4232C,L,R



### Parts List—Hydrocushion Cylinders

Find the correct assembly first, then find the needed components. The item letters (A, B, C, etc.) assigned to assemblies are referred to in the "Used In" column to identify which components belong to an assembly. The item numbers (1, 2, 3, etc.) assigned to components relate the parts list to the illustration.

Used In	Item	Part Number	Description	Comments
-----ASSEMBLIES-----				
	A	AHC16000B	HYDRCUSH CYL ASSY REAR 42M7E	REAR CYLINDERS
	B	AHC16000F	HYDRCUSH CYL ASSY FRNT 42M7E	FRONT CYLINDERS
-----COMPONENTS-----				
all	1	W3 48065	*HYDROCUSHION WLMT 4" DIA	
A	2	X3 48069A	PISTON=HYDROCUSHION CYL 4"	
B	2	X3 48069B	PISTON=HYDROCUSHION CYL 4"	
A	3	03 48070B	SPRING=3.485 OD 838 #/IN	
B	3	03 48070C	SPRING=3.25 OD 513 #/IN	
all	4	02 175034	SHIELD-BALLBUSH-4/HYDRO MACH	
all	5	02 02230	6 WATER BARRIER (NEOPRENE)	
all	6	60C145	ORING 3+1/2ID3/16CS BUNA70#341	
all	7	M3 48068	BUSHING PISTON ROD MOLDED	
all	8	15K227	HXCAPSCR 5/8-11UNC2AX4 GR5 ZIN	
all	9	15U315	LOKWASHER MEDIUM 5/8 ZINCPL	
all	10	03 48071	CAP=UPPER CYL END 4"HYDCUSH	
all	11	15G236	SQ Nut 5/8-11UNC2B SAE ZINC GR2	

# Hydrocushion Cylinders

M9V4232C,L,R MXS4232C,L,R

## Parts List—Hydrocushion Cylinder

Find the correct assembly first, then find the needed components. The item letters (A, B, C, etc.) assigned to assemblies are referred to in the "Used In" column to identify which components belong to an assembly. The item numbers (1, 2, 3, etc.) assigned to components relate the parts list to the illustration.

Used In	Item	Part Number	Description	Comments
all	12	02 18243	BOLT=HYDCYL 22+1/8LG+KEYWAY	
A	13	03 48072A	RETAINER=4"HYDROCUSHION SEAL	
B	13	03 48072B	RETAINER=4"HYDROCUSHION SEAL	
all	14	24S040	SEAL URETHNE 1-7/16 2.25 13/32	
all	15	5SP0KDEHK	NPT PLUG 1/2 HXCTRSNK GALSTL	
all	17	5SB0E0CBEO	NPTHEXBUSH 1/4X1/8 BRASS 125#	
all	18	96H020	ANGLE NEEDLE VLV 5/16TX1/8MP	
all	19	15G268	HXFINJAMNUT 1+1/2-12UNF2B ZINC	

# Hydraulic Piping and Devices

6

# Hydraulic Schematic

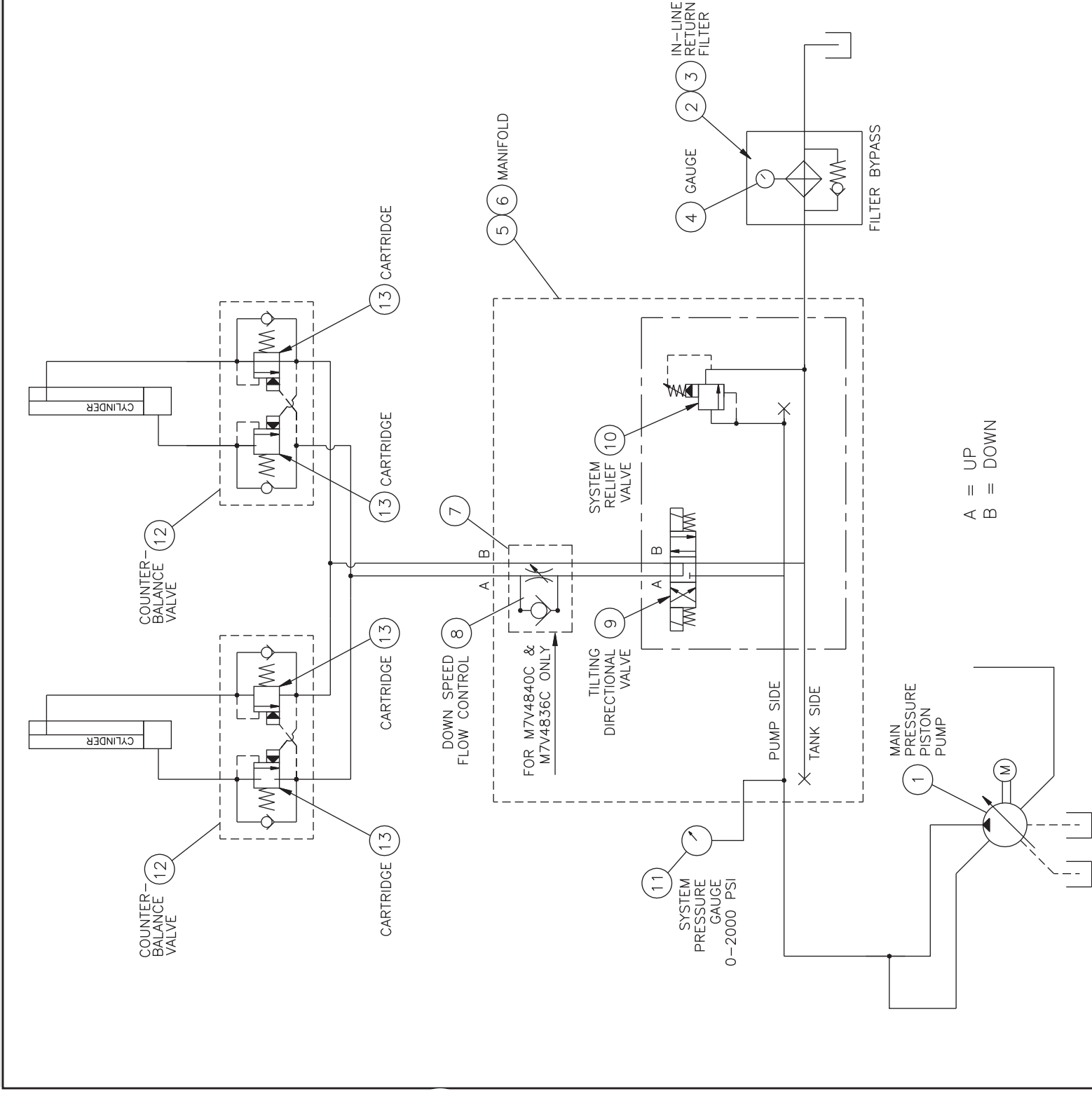
MXS4232, M9V4232, M9V4840, M7V4836



**Pellerin Milnor Corporation**  
P. O. Box 400, Kenner, LA 70063-0400

BMP050060/2013342B  
(Sheet 1 of 1)

Litho in U.S.A.



A = UP  
B = DOWN

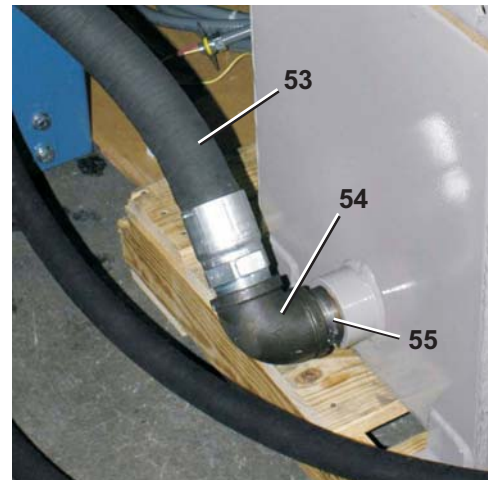
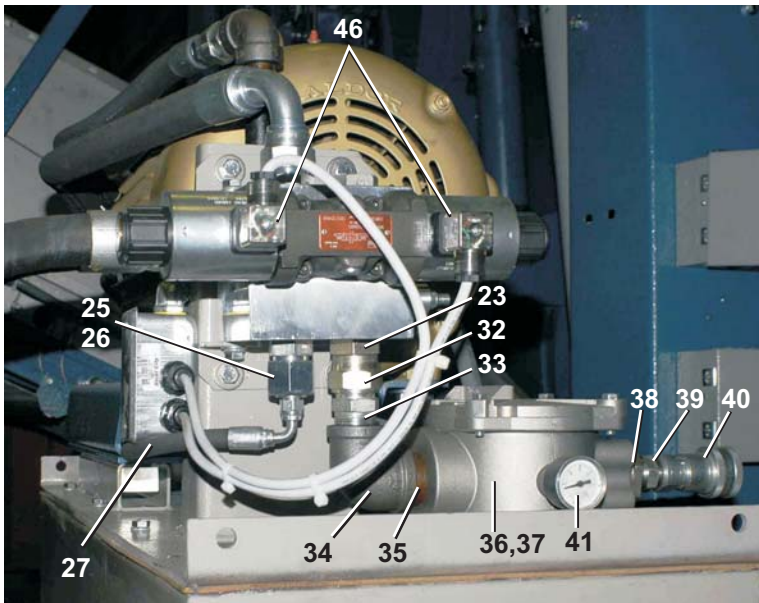
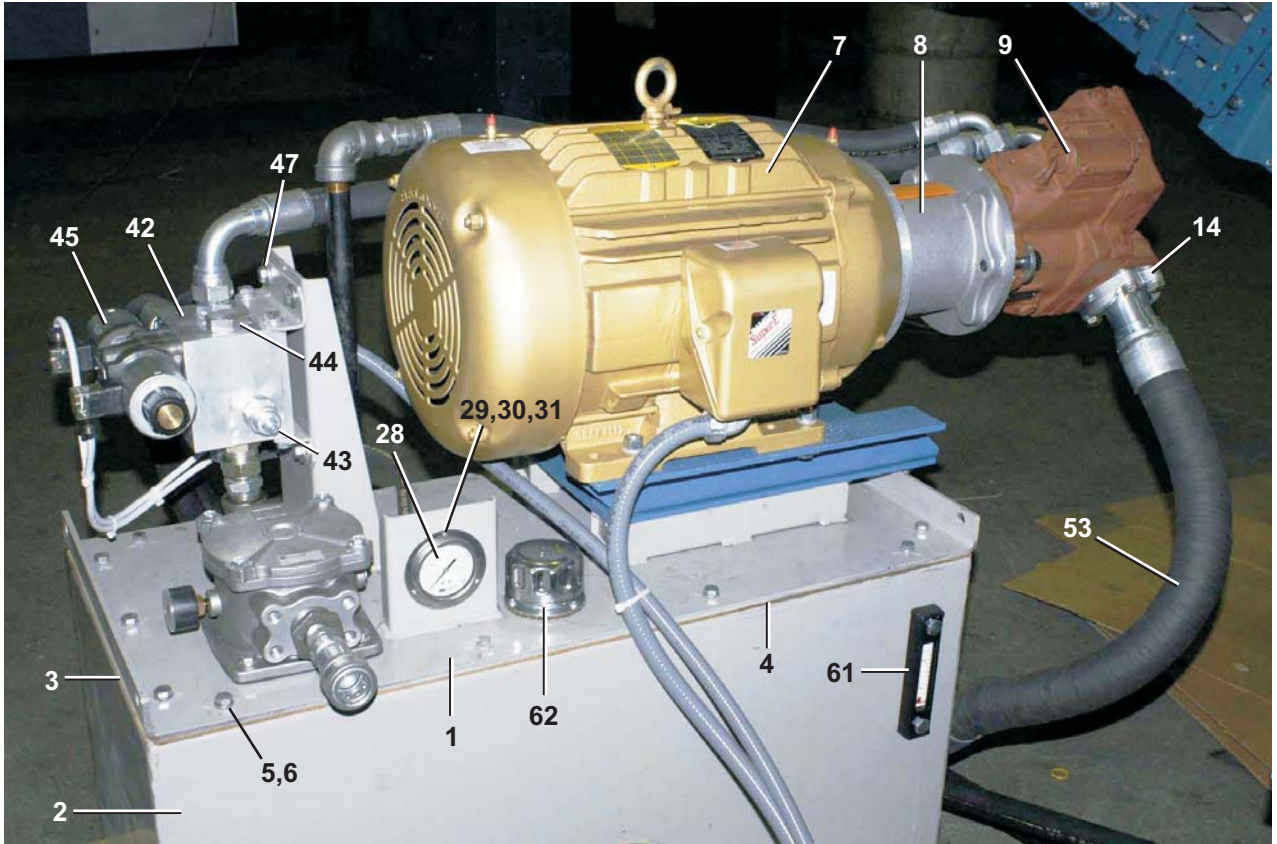
## Parts List—Hydraulic Schematic

Find the correct assembly first, then find the needed components. The item letters (A, B, C, etc.) assigned to assemblies are referred to in the "Used In" column to identify which components belong to an assembly. The item numbers (1, 2, 3, etc.) assigned to components relate the parts list to the illustration.

Used In	Item	Part Number	Description	Comments
			-----ASSEMBLIES-----	
A	AHT16004A		MXV=HYDR POWER UNIT UNIVOLT	MXS4232, M9V4232
B	AHT17000A		4840M7=HYDR POWER UNIT UNIVOLT	M9V4840, M7V4836
			-----COMPONENTS-----	
A	1	27E550566	PISTON PUMP-KAWASAKI(50BAR) K3VL 80/B	
B	1	27E550466	PISTON PUMP-KAWASAKI=35-BAR	
all	2	27E7106	IN-LINE RETURN FILTER	
all	3	27E7106A	FILTER ELEMENT-REPLACEMENT	
all	4	27E7103A	GAUGE=WIKA 1/8NPT(ON 27E7103)	
all	5	27E5506E	DAMAN MANIFOLD #AD05HP013S/S	
B	6	96DH490D	RETAINER/SEAL,SUN#990120009	
B	7	96DH490B	BODY, SUN #DJD	
B	8	96DH490C	CARTRIDGE, SUN #NCFB-LCN	
all	9	96RH711E37	DIRECTIONAL CONT. VLV.D05-NG10	
all	10	27E5506F	SUN HYD. CARTRIDGE #RDFALAN	
all	11	30N125G	GAUGE 0-2000PSIBAR 1/4 BACK	
all	12	96DH472	COUNTERBALANCE VALVE-SUN BODY	
All	13	96DH472A	CARTRIDGE, COUNTERBALANCE VLV.	

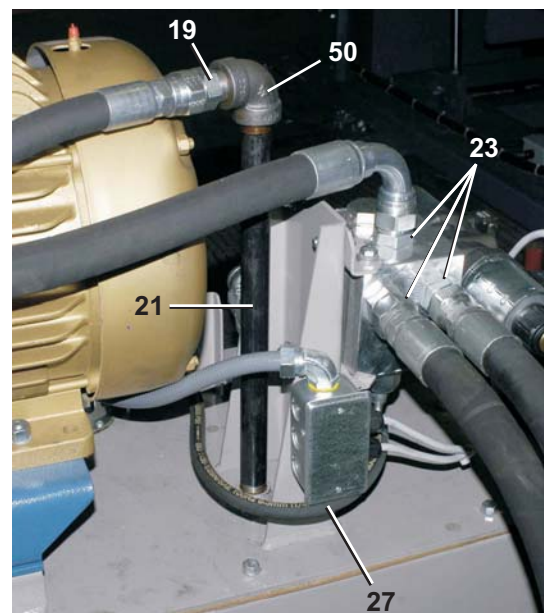
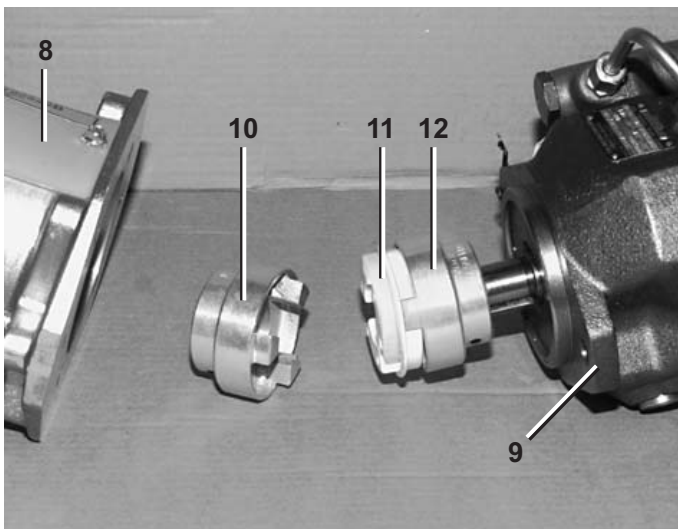
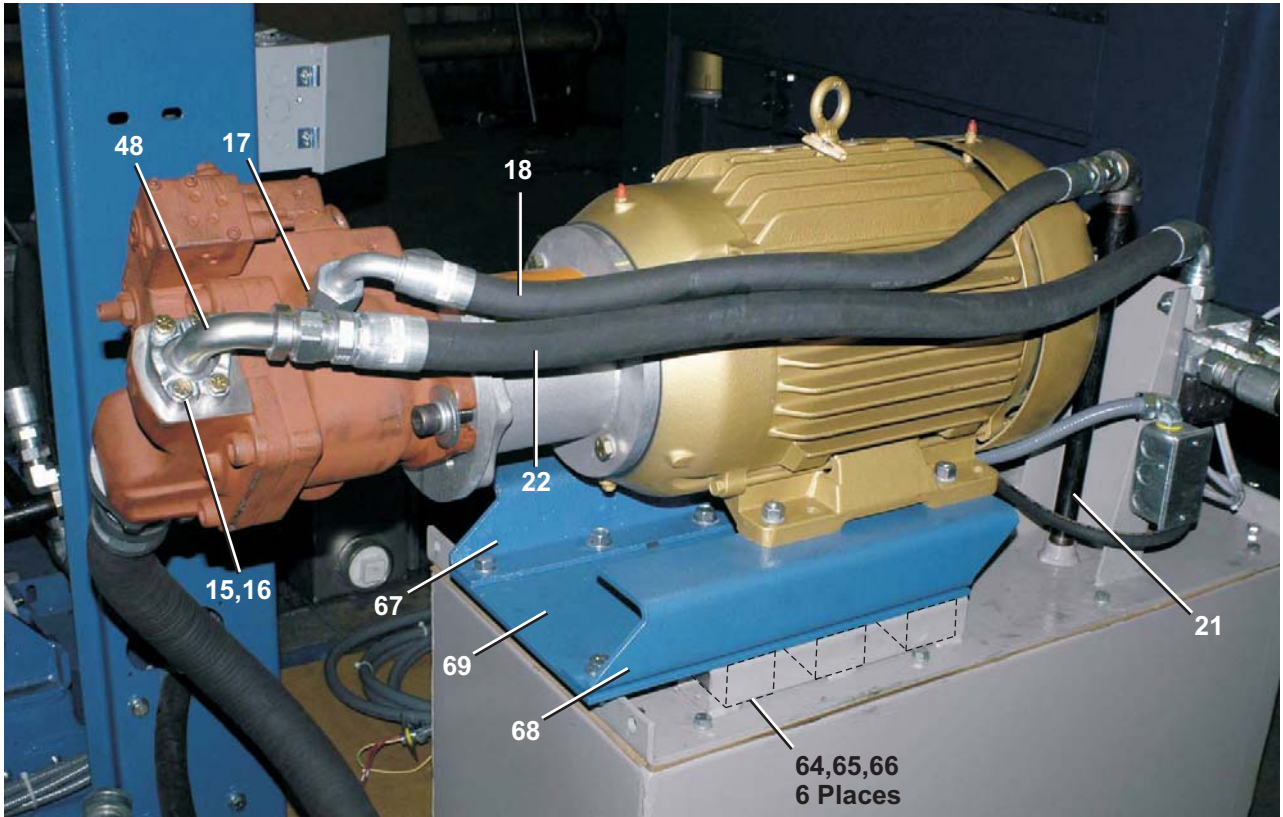
# Hydraulic Tank

M9V4232C,L,R MXS4232C,L,R



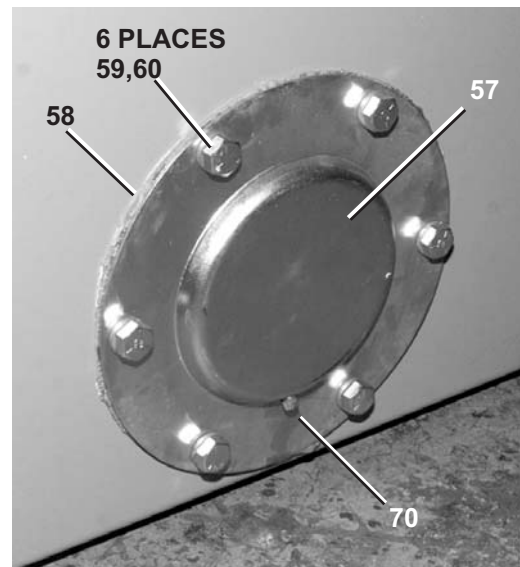
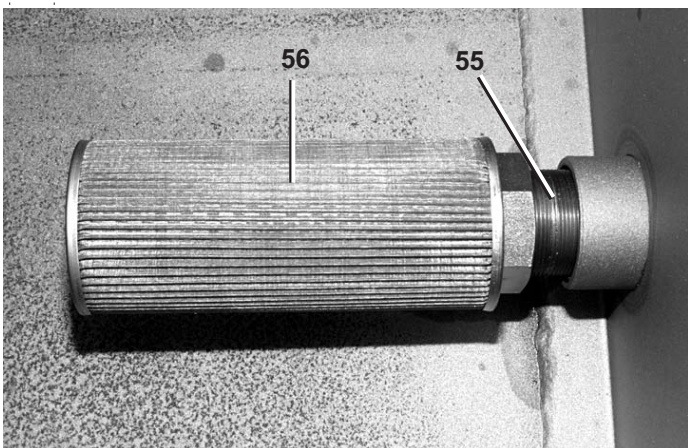
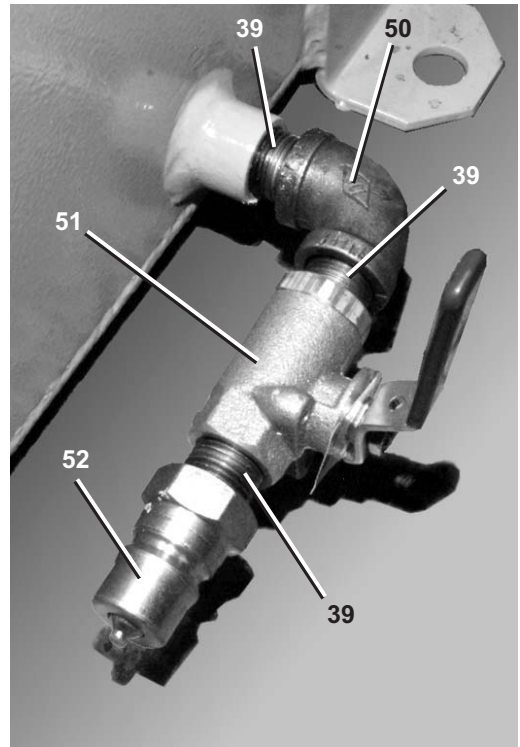
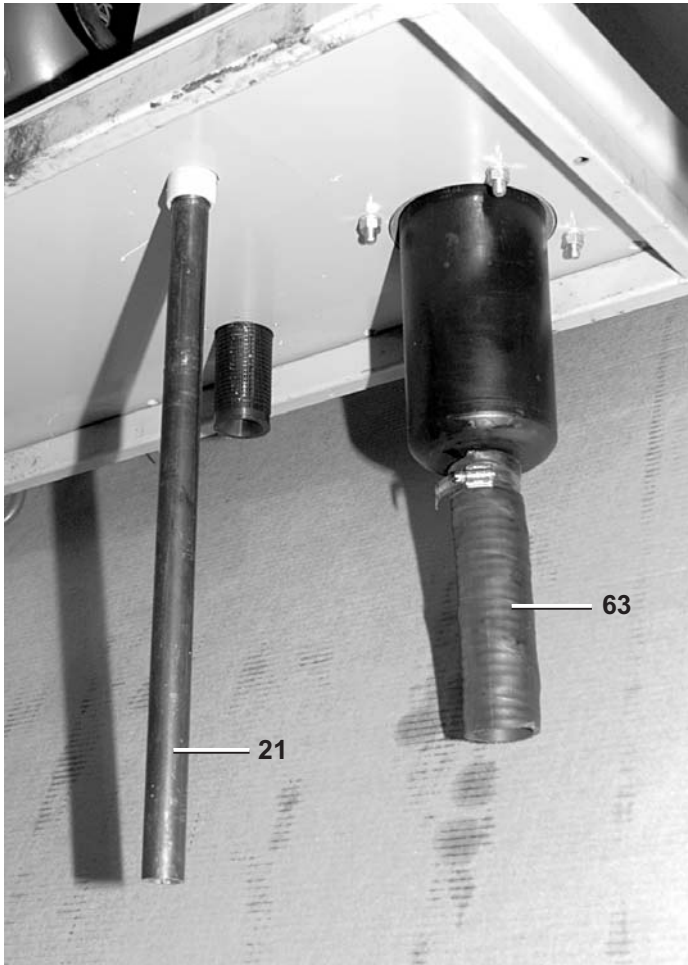
# Hydraulic Tank

M9V4232C,L,R MXS4232C,L,R



# Hydraulic Tank

M9V4232C,L,R MXS4232C,L,R



# Hydraulic Tank

M9V4232C,L,R MXS4232C,L,R

## Parts List—Hydraulic Tank

Find the correct assembly first, then find the needed components. The item letters (A, B, C, etc.) assigned to assemblies are referred to in the "Used In" column to identify which components belong to an assembly. The item numbers (1, 2, 3, etc.) assigned to components relate the parts list to the illustration.

Used In	Item	Part Number	Description	Comments
			-----ASSEMBLIES-----	
	A	AHT16004A	MXV=HYDR POWER UNIT UNIVOLT	
			-----COMPONENTS-----	
all	1	W7 10225	WLMT=OIL RESEVOIR TOP	
all	2	W3 16523A	WLMT=HYDR TANK	
all	3	03 16532	HYDR TANK SM TOP GASKET	
all	4	03 16531	HYDR TANK LG TOP GASKET	
all	5	15K095	HXCPSCR 3/8-16UNC2AX1 GR5 ZINC	
all	6	15K255	HEXCAPSCR 3/4-10X6 GR8/2C	
all	7	39T150ACU	15HP 4P TEFC UNIVOLT	
all	8	27E5510C	PUMP-TO-MOTOR MOUNT 6.00"LG.	
all	9	27E550566	PISTON PUMP-KAWASAKI(50BAR) K3VL 80/B	
all	10	27E5510	COUP.ASSY.=1+5/8"BOREX3/8KW	
all	11	27E5510B	HYTREL INSERT-MAGNA#M370H5	
all	12	27E5510A	COUP.ASSY.=1+1/4"BOREX5/16KW	
all	14	27E5505C	SPLIT FLANGE-2"	
all	15	27E5504BA	O-RING FOR (27E5504B)	
all	16	27E5504B	PRESS.SPLITFLANGE FOR VAR.PUMP	
all	17	52ZCF50LOS	TUBEFITSTR3/4X1/2"#12-8F50LOS	
all	18	60EH50C28A	ASSY=HYD HOSE 3/4"X28"LG	
all	19	52ZC0PS001	TUBEFITSTR3/4"#12-FLO-S	
all	21	5N0P16AF42	NPT NIP 3/4X16 TBE BLKSTL SK40	
all	22	60EH80C36K	ASSY=HYDRAULIC HOSE 1"X36"LG	
all	23	52XY0KR050	STRDPT 3/4MX1"MJ#6400-16-12-0	
all	24	07 10241	PRESSURE MANIFOLD MTG ANGLE	
all	25	52ZC00S003	TUBEFIT STRTHDCN3/4"#12F50LO-S	
all	26	52ZL00S006	TUBEFITENDRED3/4TX1/4T FACESL	
all	27	60EH21C18A	ASSY=HYDRALIC HOSE 1/4X18 LG	
all	28	30N125G	GAUGE 0-2000PSI\BAR 1/4 BACK	
all	29	15U102	LOCKWASHER MEDIUM #6 SS18-8	
all	30	15G075	HEX MACH SCREW NUT 6-32UNC2 S	
all	31	15N050	RDMACSCR 6-32UNC2X1/2 SS18-8	
all	32	52XY1AP012	STRADAPT1"MORXFJS#6402-16-16-0	
all	33	52XY1AP010	STRADPT 1"MXMJIC #2404-16-16	
all	34	5SL1EMFA1A	NPT ELBOW 90DEG 1.25X1" BLKMAL	
all	35	5N1ECLSF42	NPT NIP 1.25XCLS TBE BLKSTLS40	



# Hydraulic Tank

M9V4232C,L,R MXS4232C,L,R

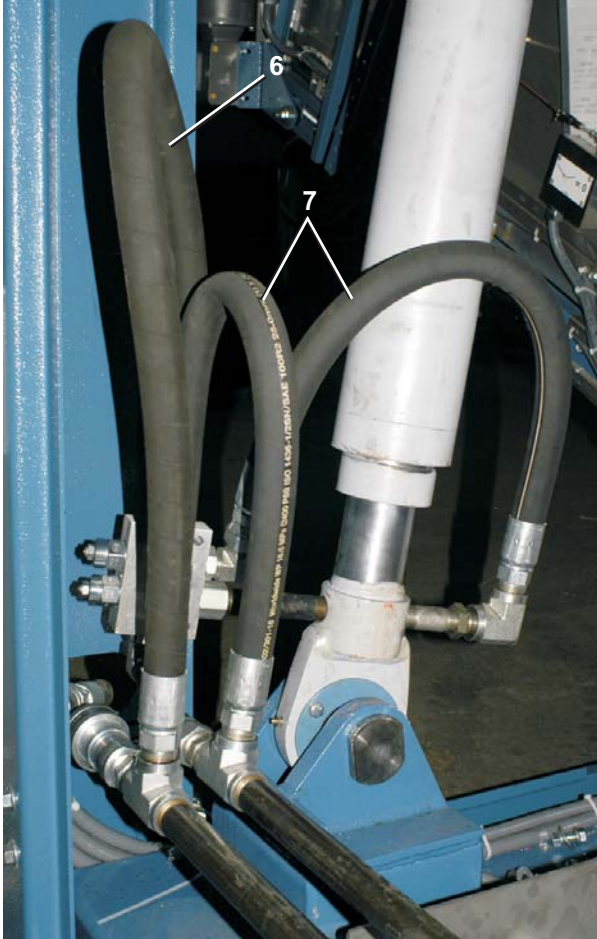
## Parts List—Hydraulic Tank

Find the correct assembly first, then find the needed components. The item letters (A, B, C, etc.) assigned to assemblies are referred to in the "Used In" column to identify which components belong to an assembly. The item numbers (1, 2, 3, etc.) assigned to components relate the parts list to the illustration.

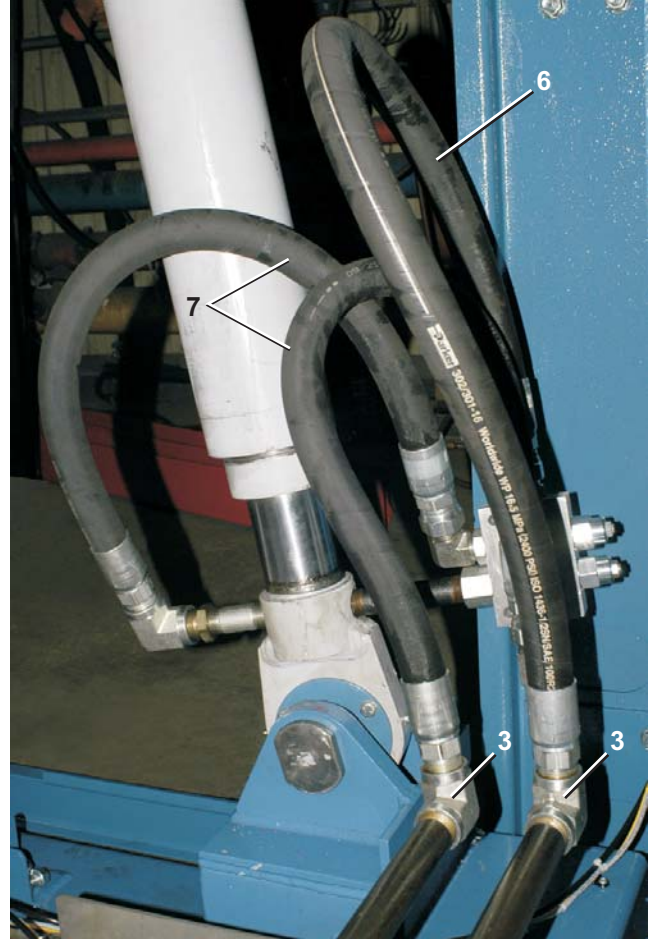
Used In	Item	Part Number	Description	Comments
all	36	27E7106A	FILTER ELEMENT-REPLACEMENT	
all	37	27E7106	IN-LINE RETURN FILTER	
all	38	5SB1E0KMFO	NPTHEXBUSH 1.25X1/2BLKMAL 150#	
all	39	5N0KCLSF42	NPT NIP 1/2XCLS TBE BLKSTL S40	
all	40	52XY0KP00X	1/2"QUICK DISCONN.FEM#H4-62	
all	41	27E7103A	GAUGE=WIKA 1/8NPT(ON 27E7103)	
all	42	27E5506E	DAMAN MANIFOLD #AD05HP013S/S	
all	43	27E5506F	SUN HYD. CARTRIDGE #RDFA-LAN	
all	44	52PY1AR001	HEX PLUG 1"OR #6408-16-0	
all	45	96RH711E37	DIRECTIONAL CONT. VLV.D05-NG10	
all	46	12M3240V3F	SOLE.CONN.100-240VAC 3FT	
all	47	15G198	HXFLGNUT 3/8-16 ZINC	
all	48	52JY1AR013	EL90COD61 1"MJXFLG.#1704-16-16	
all	50	5SL0KNFA	NPT ELB 90DEG 1/2 GALMAL 150#	
all	51	96D034	BALLVALVE 1/2" WATTS #6400-SS	
all	52	52XY0KP00Y	1/2"QUICK DISCONN.MALE #H4-63	
all	53	60EH95C30A	ASSY=HYDRAULIC HOSE 2"X30LG	
all	54	5SL2AMFA1K	NPT ELB 90DEG 2X1.5 BLKMAL150#	
all	55	5N2ACLSB42	NPT NIP 2XCLS TBE BLKSTL SK40	
all	56	27E7108	SUCTION STRAINER 2" PORT	
all	57	02 18618	COVER=BEARHOUSE	
all	58	02 18105A	HYD TANK COVER GASKET	
all	59	15U300	LOKWASHER REGULAR 1/2 ZINC PLT	
all	60	15K145	HXCAPSCR 1/2-13UNC2AX3/4 GR5 P	
all	61	27E7301	SIGHTGAUGE-FLUID:STAUFF#SNA-2T	
all	62	27E7201	FILLER-BREATH-FILT.LHA#ABB-40N	
all	63	5N1K07AF42	NPT NIP 1.5X7 TBE BLKSTL SK40	
all	64	02 19283	NUT=1/2-13UNCX1+1/2SQ SPEC	
all	65	15K171B	HEXCAPSCR 1/2-13X1+3/4 GR8 ZIN	
all	67	07 10275	MOTOR MTN BRKT-RT 47BAR	
all	68	07 10275A	MOTOR MTN BRKT-LF 47BAR	
all	69	07 10276	MOTOR MOUNT PLATE-47BAR	
all	70	5SP0CGFSS	NPT PLUG 1/8 SQ SOLID GALSTL	

# Hydraulic Hoses & Piping

M9V4232C,L,R M9S4232C,L,R MXS4232C,L,R



Right Cylinder



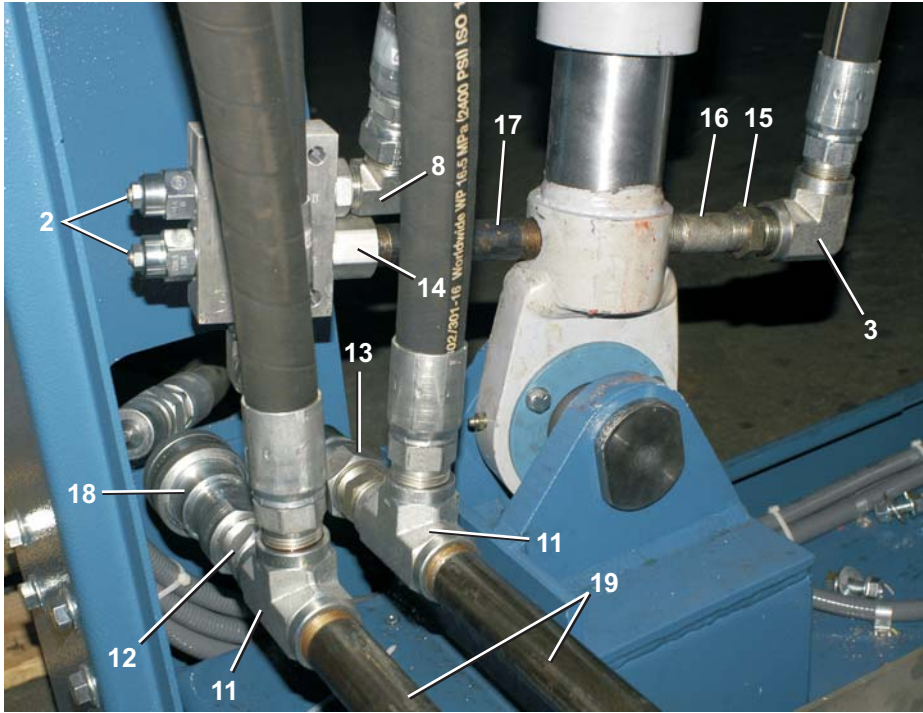
Left Cylinder



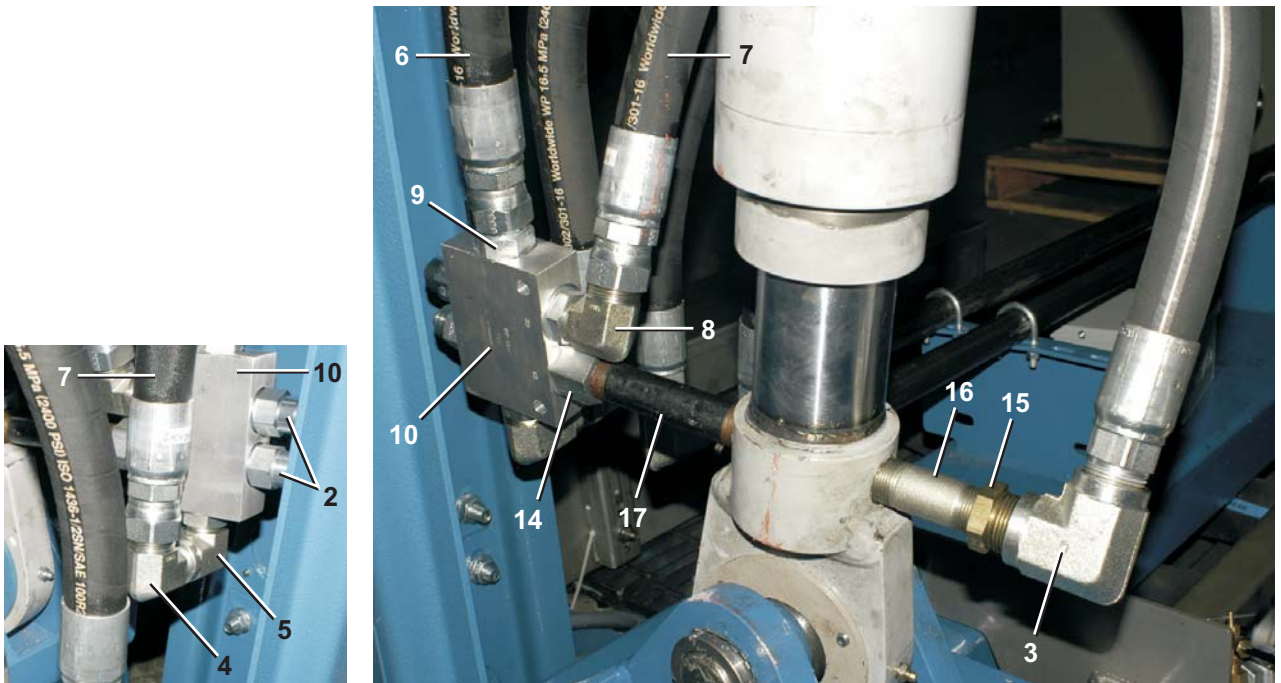
Manifold

# Hydraulic Hoses & Piping

M9V4232C,L,R M9S4232C,L,R MXS4232C,L,R



Right Cylinder



Typical (2 places)

Left Cylinder

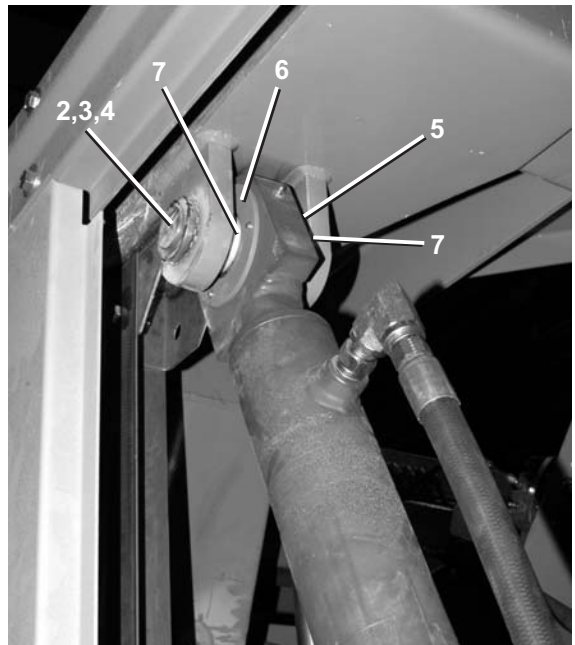
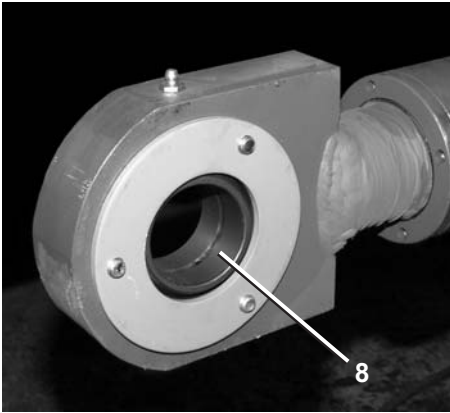
# Hydraulic Hoses & Piping

M9V4232C,L,R M9S4232C,L,R MXS4232C,L,R

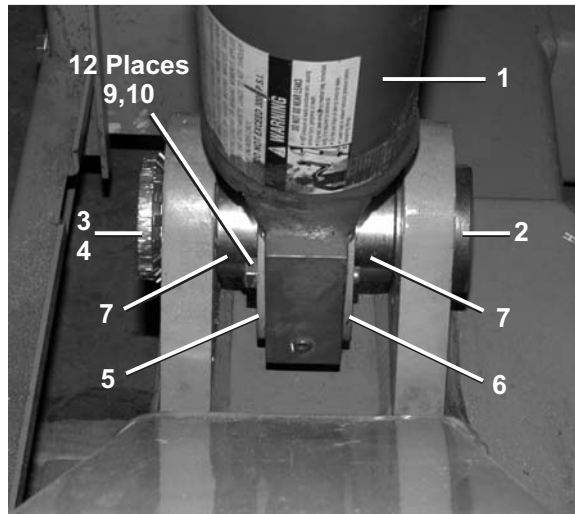
<b>Parts List—Hydraulic Hoses &amp; Piping</b> Find the correct assembly first, then find the needed components. The item letters (A, B, C, etc.) assigned to assemblies are referred to in the "Used In" column to identify which components belong to an assembly. The item numbers (1, 2, 3, etc.) assigned to components relate the parts list to the illustration.				
Used In	Item	Part Number	Description	Comments
-----ASSEMBLIES-----				
	A	AHT16000	HYDRAULIC HOSES&PIPING ASSY.	
-----COMPONENTS-----				
all	1	60EH80C96A	ASSY=HYDRAULIC HOSE 1"X96"LG	
all	2	96DH472A	CARTRIDGE, COUNTERBALANCE VLV.	
all	3	52JY1AR006	ELBOW 90DEG 1" FEM #5504-16	
all	4	52JY0PR010	ELB 3/4M X1"MJIC #2501-16-12	
all	5	52JY0PR008	ELB.3/4MORXF #6805-12-12NWO	
all	6	60EH80C44A	ASSY=HYDRAULIC HOSE 1"X44"LG	
all	7	60EH80C34A	ASSY=HYDRAULIC HOSE 1"X34"LG	
all	8	52JY0PR011	ELB-3/4MORX1MJIC#6801-16-12NW0	
all	9	52XY0KR050	STRDPT 3/4MX1"MJ#6400-16-12-0	
all	10	96DH472	COUNTERBALANCE VALVE-SUN BODY #YAL	
all	11	52VY1AR006	TEE 1"FP #5605-16-16-16	
all	12	52LY1AR003	HEXPIP NIP 1"=#5404-16-16	
all	13	52XY1AP001	1"QUICKDISCONNECT#H8-62COUPLER	
all	14	52XY0KR045	STRDPT 3/4MORXF #6405-12-12-0	
all	15	52AY01R005	HEXPTPEBUSH 1"MX3/4F5406-16-12	
all	16	52LY0PR003	HEXPIP NIP 3/4X3"HEXBODY	
all	17	5N0P06AF82	NPT NIP 3/4X6 TBE BLKSTL SK80	
all	18	52XY1AP002	1"QUICKDISCONNECT #H8-63NIPPLE	
all	19	5N1A52AF82	NPT NIP 1X52 TBE BLKSTL SK80	

# Hydraulic Tilt Cylinders

M9V4232, MXS4232, M7V4836, M9V4840



Typical Hydraulic Tilt Cylinder



# Hydraulic Tilt Cylinders

M9V4232, MXS4232, M7V4836, M9V4840

<b>Parts List—Hydraulic Tilt Cylinders</b>				
Find the correct assembly first, then find the needed components. The item letters (A, B, C, etc.) assigned to assemblies are referred to in the "Used In" column to identify which components belong to an assembly. The item numbers (1, 2, 3, etc.) assigned to components relate the parts list to the illustration.				
Used In	Item	Part Number	Description	Comments
-----ASSEMBLIES-----				
	A	GHT17010	ASSY=4840M HYDRAULICS	M7V4836_, M7V4840_, M9S4840_
	B	GHT16000	HYD.MOTOR&PUMP ASSY 4232 M7E	M9V4232_, MXS4232_
-----COMPONENTS-----				
A	1	27E163A56A	HYD.CYL.3.25"X2.5"X56"STK.	
B	1	27E1647A64	HYD.CYL.2-STAGE 64"STROKE	
all	2	X3 65141	BOLT=2.00 SFTDIA X 5.25L HYD	
all	3	56AHN09	N09 BEARING LOCKNUT	
all	4	56AHW09	W09 BEARING LOCKWASHER	
all	5	03 65142	WASH=HYD4.75ODX2.62IDW/HOLES	
all	6	X3 65142A	WASH=HYD4.75ODX2.62IDW/TAP	
all	7	X3 65145	SPCR=HYDCYL MNT2"BALBUSH SM	
all	8	54A705A	SPHERICAL PLAIN BEARING=2"ROLLBRG#B32-L	
all	9	15K120	HXCAPSCR 3/8-16UNC2AX2 GR5 ZIN	
all	10	15U255	LOCKWASHER MEDIUM 3/8 ZINCP	

## Assuring Proper Counterbalance Valve Operation-Hydraulic Tilting Washer-Extractors and Centrifugal Extractors

Various conditions, such as a non-functioning or misadjusted limit switch, a seized pivot ball bushing or, a counterbalance valve failure, can cause erratic or uneven up/down movement of the hydraulic tilt cylinders. This document addresses normal counterbalance valve operation and adjustment.

In most cases, it is not possible to perform counterbalance valve adjustments without entering the housing and/or reaching under the raised cylinder.

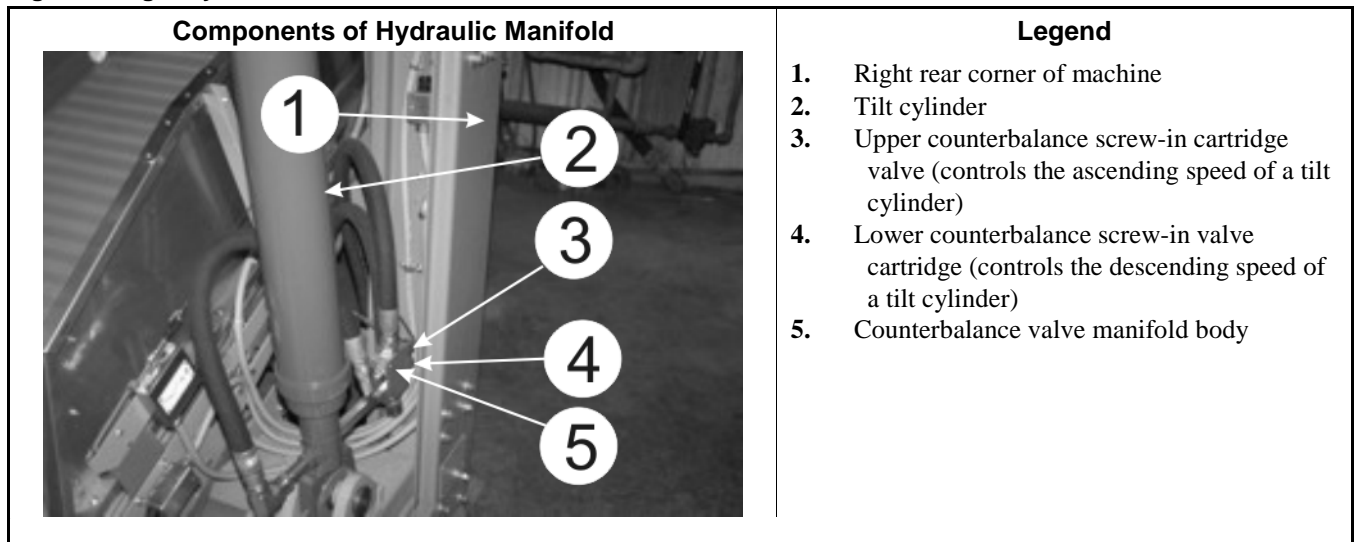


**WARNING 1: Entangle and Crush Hazard**—The machine shell will crush your body or limbs if it descends or falls while you are under it. The housing can descend with power off or on. Manual operation of tilting valves overrides safety interlocks. Improper operation of manual tilting valves may cause the shell to descend.

- Never operate the manual tilting with anyone under the machine.
- Use the safety stands as appropriate. If used, follow instructions in the manual.
- Read the SAFETY ALERT on use of the *access panel interlock safety bypass* switch in the service manual before setting the maintenance key switch to "Maintenance Only "
- After adjustments, return the key switch to "Safe Operation" and remove the key to a secure area before resuming normal operation.

### 1. Observing Tilt Cylinder Operation

Figure 1: Right Cylinder and associated Counterbalance Valves



#### 1.1. Setup

1. Remove the left and right door side panels and identify the components shown in [Figure 1](#).
2. Set the *access panel interlock safety bypass key* switch to the "Maintenance Only" position.

## 1.2. Observations

Use the key pad controls, as explained in the manuals, to manually raise and lower the shell several times as described below, and verify the following proper operation.

1. Carefully move the shell from full down to full up. Verify that the cylinders move in unison and reach the top at approximately the same time.
2. Raise the shell fully and release the controls. Observe the machine for at least 3 minutes to assure that the shell does not drift down.
3. Manually lower the shell completely. Verify that the tilt cylinders move in unison and reach the bottom at approximately the same time.
4. If the cylinders exhibit any erratic movement that can be attributed to the counterbalance valves, perform the service explained below.

## 2. Tilt Cylinder Hydraulic Components and Functions

The hydraulic schematic provided in the service manual titled "Hydraulic Schematic " shows the counterbalance circuitry.

- 2.1. **Components**—[Figure 1](#), item 5 shows one of the two counterbalance manifolds. Each manifold has two screw-in counterbalance valve cartridges (items, 3 and 4). Referring to [Figure 2](#), each counterbalance valve cartridge has the following:

- A base nut (item 5) used to screw the valve into the manifold.
- A lock nut which must be turned slightly using an open-end wrench (item 1).
- An adjustment screw, (item 3) which must be turned with a hex key wrench.

## 2.2. Functions of Components

**Manifold (Milnor P/N 96DH472)**—Provides feedback between the two counterbalance valves

**Counterbalance valve (Milnor P/N 96DH472A)**—Provides the following:

- Permits unrestricted flow into a cylinder, while controlling exhaust flow from the cylinder.
- Protects against cylinder drifting down
- Reduces flow when lowering to limit speed
- Provides speed adjustment so cylinders can be made to travel in unison
- Pilot action locks machine shell from coming down if pressure is lost due to leaks

**Tip:** For an in-depth explanation of these components, see [www.sunhydraulics.com](http://www.sunhydraulics.com) or download Sun's virtual counterbalance valve simulation ([www.e4training.com/hyd03/sitemap.htm](http://www.e4training.com/hyd03/sitemap.htm)).

## 3. Counterbalance Valve Adjustments

Use this procedure on all four counterbalance valves if you observe any erratic movements listed above.

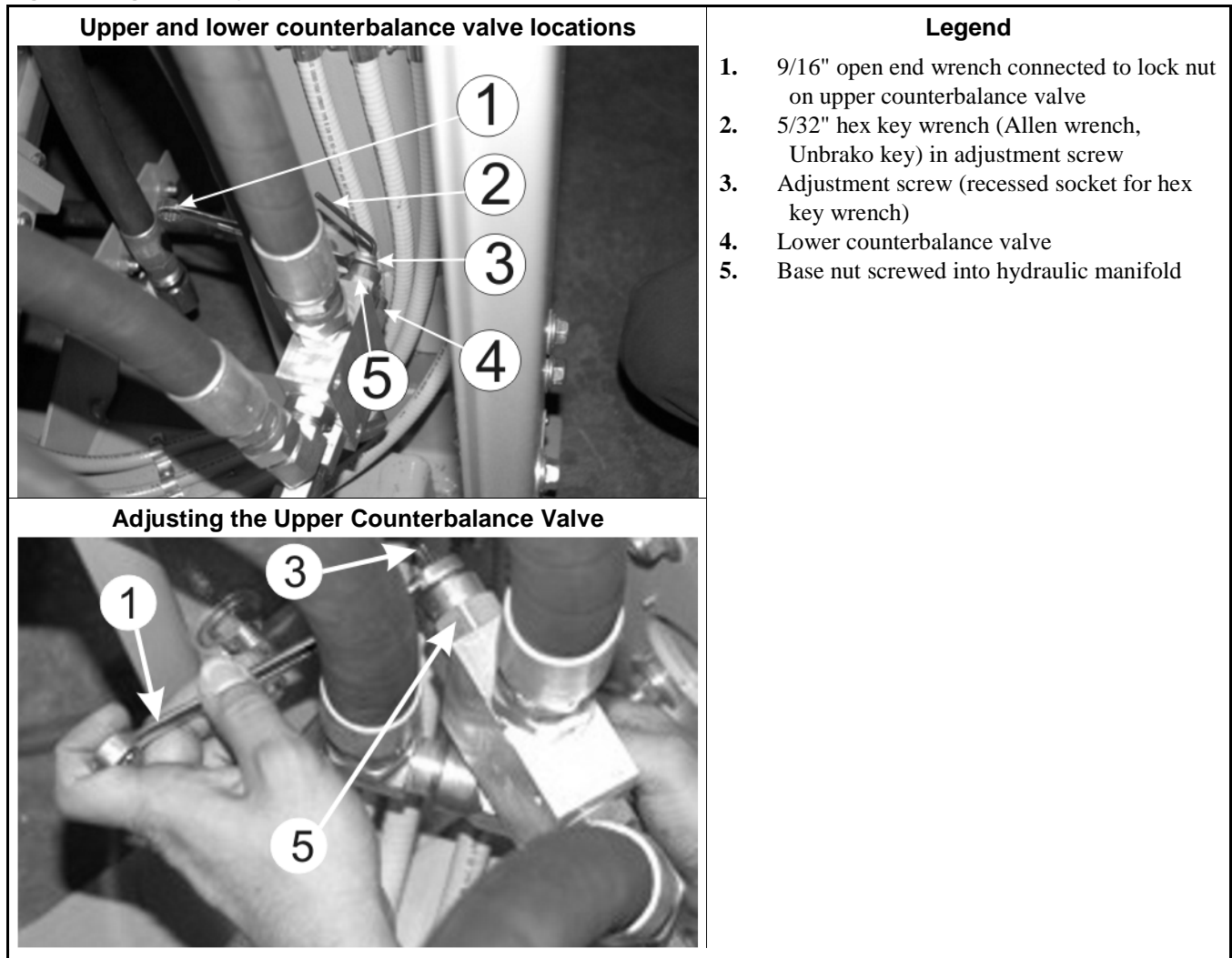
- 3.1. **Coarse Adjustments**—Referring to [Figure 2](#),

1. Loosen the lock nut with a 9/16" open end wrench ( item 1 ) .
2. Using a 5/32" hex key wrench (Allen wrench, Unbrako key), screw the adjustment nut ([Figure 2](#), item 2) in fully.



3. Back off the adjustment screws
  - a. upper valve -- one full turn (360 degrees)
  - b. lower valve -- 3/4 turn (270 degrees)
4. While holding the adjustment nut stationary, tighten the lock nut.

**Figure 2: Right Side Hydraulic Manifold**



**3.2. Fine Adjustments**—By making small adjustments of about a 1/4 of a turn to either counterbalance valve, you should be able to get the two cylinders to move up and down in unison so that both sides reach end of travel at approximately the same time. Be careful to hold the adjustment screw (Figure 2, item 3) stationary, while tightening the lock nut (Figure 2, item 1). Screw out the adjustment (Figure 2, item 3) to slow downward movement. Screw in the adjustment (Figure 2, item 3) to increase speed.

#### 4. Return Machine to Normal Operation

Remove the tilt safety stands if they were used.

1. Manually tilt the shell down.

Assuring Proper Counterbalance Valve Operation-Hydraulic Tilting Washer-Extractors and Centrifugal Extractors

2. Replace the door side panels. Return the key switch to "safe operations" and move the key to a secure area.

— End of BIPEUM01 —

# Control and Sensing Devices

7

# Door Safety Switch Installation

M7E4232C,L,R M7V4232C,L,R M9E4232C,L,R M9V4232C,L,R

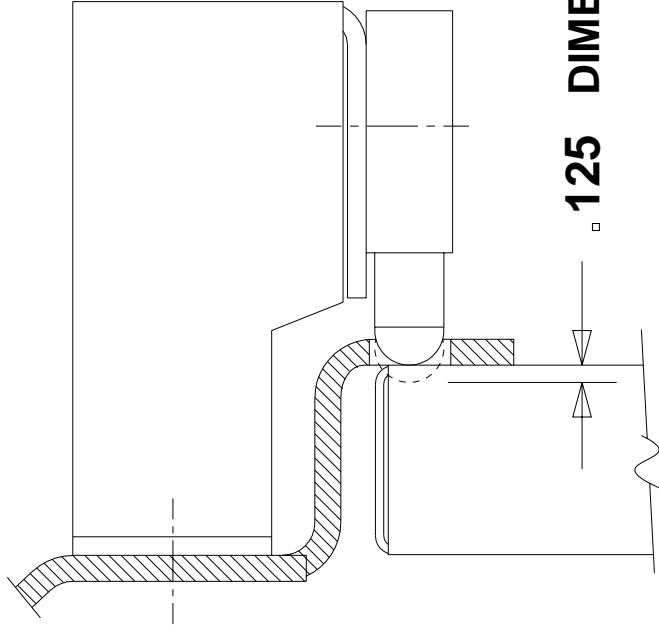
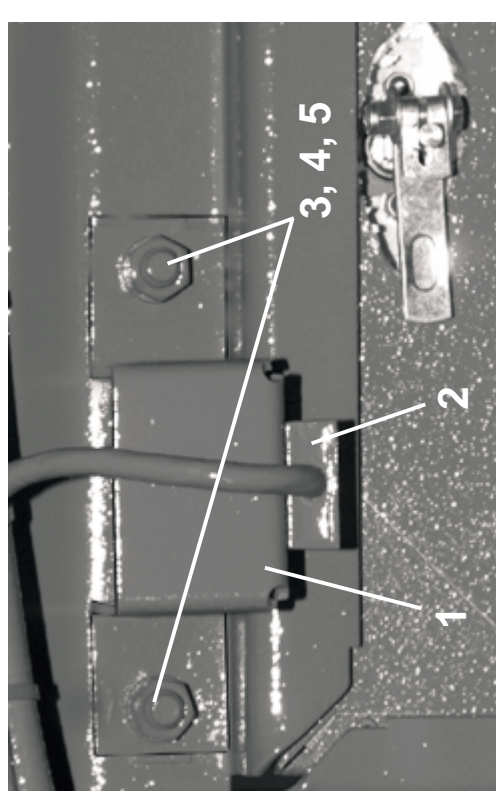
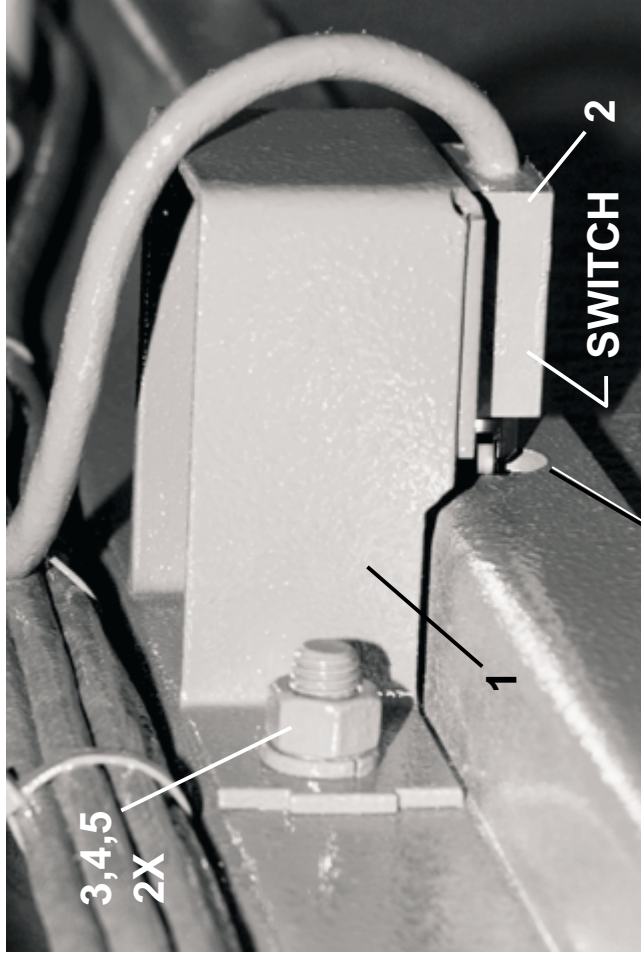
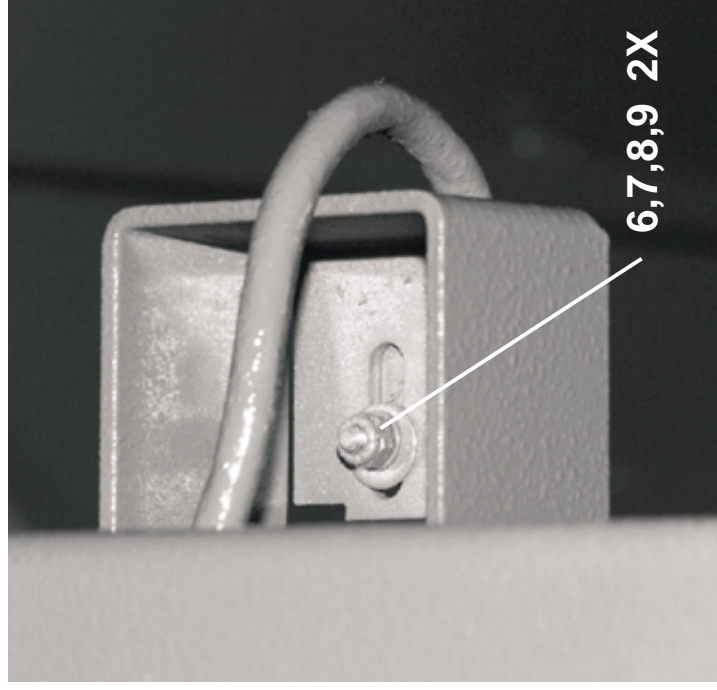
BMP9400026/2001204V  
(Sheet 1 of 2)



Pellerin Milnor Corporation  
P. O. Box 400, Kenner, LA 70063-0400

Litho in U.S.A.

THIS INSTALLATION IS TYPICAL FOR ALL DOOR PANELS



SWITCH IS ENGAGED WHEN THE DOOR PANEL STRIKES THE ROLLER PLUNGER THROUGH THE ACCESS HOLE.

SEE DIMENSION "A" SHOWN IN FIGURE 1 FOR LOCATION WHEN INSTALLING SWITCH. ANYTHING LESS OR GREATER THAN DIM. "A" WILL RENDER THIS SAFETY DEVICE INOPERABLE!

FIGURE 1



Pellerin Milnor Corporation  
P. O. Box 400, Kenner, LA 70063-0400

Litho in U.S.A.

**Parts List—Door Safety Switch Installation**

Find the correct assembly first, then find the needed components. The item letters (A, B, C, etc.) assigned to assemblies are referred to in the "Used In" column to identify which components belong to an assembly. The item numbers (1, 2, 3, etc.) assigned to components relate the parts list to the illustration.

Used In	Item	Part Number	Description	Comments
			-----ASSEMBLIES-----	
	A	GG516006	INSTL=DOOR SAFETY SW. 42M7E	INSTALLATION
			-----COMPONENTS-----	
all	1	03 16264B	COSMETIC DOOR SAFETY SW/BRKT	
all	2	09RM01418G	CAPSW 18'ROTARY ACTUATE GOLD	
all	3	15K162	HXCAPSCR 1/2-13UNC2AX1.5 GR5 P	
all	4	15U300	LOKWASHER REGULAR 1/2 ZINC PLT	
all	5	15G230	HXNUT 1/2-13UNC2B SAE ZINC GR2	
all	6	15K041	HXCAPSCR 1/4-20UNC2AX1 GR 5 ZI	
all	7	15U185	FLATWASHER(USS STD) 1/4" ZNC P	
all	8	15G177	HXNUT 1/4-28UNF2B SAE ZINC GR2	
all	9	15U180	LOCKWASHER MEDIUM 1/4 ZINCPL	



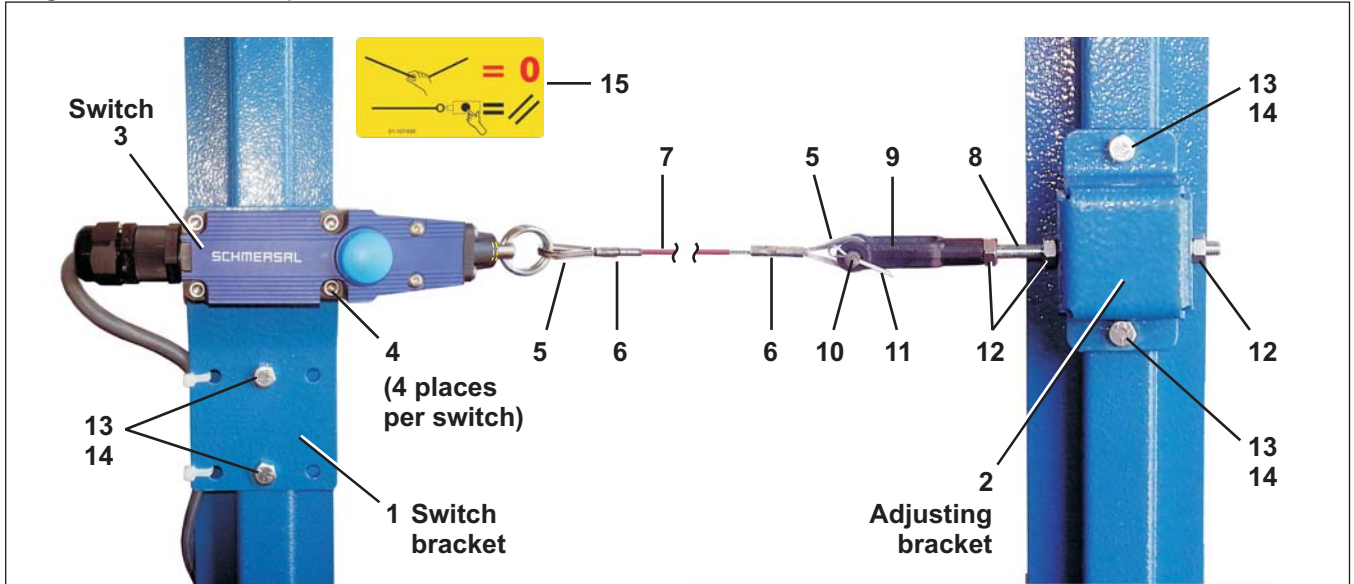
# M7E Conveyor Assemblies

8

# Pull-wire Stop Switch

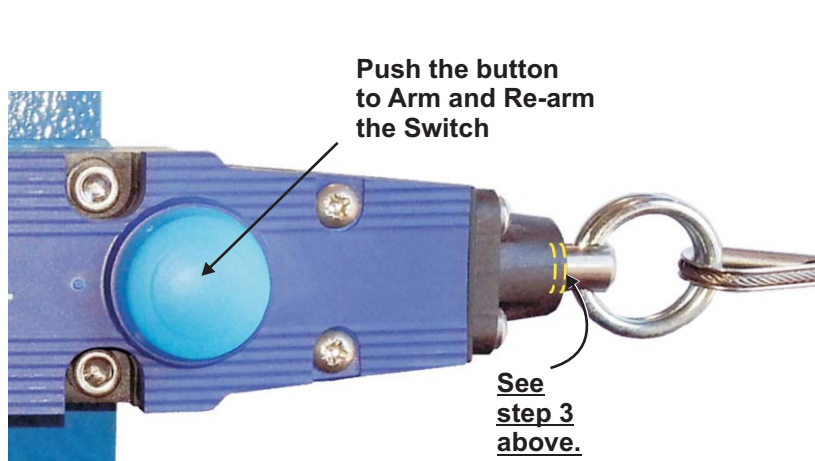
All Conveyors

Figure 1: Pull-wire Stop Switch Installation



**Installation and operation:**

1. Install the switch bracket, switch, and adjusting bracket to the conveyor side supports as shown. (Install pull-wire stop switch to both sides of all conveyors.)  
For long spans, intermediate wire supports are required every 2 m to 5 m (6 ft to 16 ft). Sufficient space must be provided so that maximum perpendicular force on the wire to activate the switch is 200 N (45 pounds) and the maximum deflection of the wire is 400 mm (15").
2. Assemble and install the cable (pull cord), thimbles, and sleeves so that the cable is tight but does not begin to move the switch shaft.
3. Adjust the position of the threaded rod (item 8) so that the cable pulls the switch shaft out until the first of two notches on the shaft is visible but the second notch is not.
4. Tighten the nuts on the threaded rod (item 12) to hold it at this position.



5. Press the button on the switch to ARM. The button should remain depressed. If it does not, the switch shaft is not in the correct position.
6. Press the button to RE-ARM the switch after the wire has been tripped.



# Pull-wire Stop Switch

All Conveyors

<b>Parts List—Pull-wire Stop Switch</b>				
Find the correct assembly first, then find the needed components. The item letters (A, B, C, etc.) assigned to assemblies are referred to in the "Used In" column to identify which components belong to an assembly. The item numbers (1, 2, 3, etc.) assigned to components relate the parts list to the illustration.				
Used In	Item	Part Number	Description	Comments
			-----ASSEMBLIES-----	
	A	ALC40005E	PULL-WIRE STOP SWITCH ASSY	
			-----COMPONENTS-----	
	1	04 20066	WIREPULL SWITCH BRACKET	CONVEYORS PLUS CONWA/CONLO
	1	04 24128	SAFETY SW MTG PLATE-4232M	EXTRACTOR CONVEYORS
all	2	04 20067	WIREPULL ADJUSTING BRKT	
all	3	09RS0002	PULL-WIRE SW SCHMERSAL#ZQ 700-11	
all	4	15K022B	SOKCPSCR 10-24UNC X 1+1/2"LG SS18	
all	5	27A951	1/16" SS WIRE ROPE THIMBLE	
all	6	27A952	1/16" OVAL SLEEVE S/S	
all	7	27A953	CABLE-AIRCRAFT 1/16SS7X7REDCV	
all	8	17R015	THRD ROD 1/4-28UNFX4.5" ZNC PL	
all	9	17A004	ADJ YOKE END 1/4-28 XYLAN COAT	
all	10	17A004A	CLEVIS PIN 1/4"X3/4"DRILLED SS	
all	11	15H031	STDCOTTERPIN 3/32X3/4 SS18-8	
all	12	15G177	HXNUT 1/4-28UNF2B SAE ZINC GR2	
all	13	15K038B	1/4-20X 1/2 HEXFLANGE SCREW	
all	14	15G178	1/4"-20 HEXFLANGE NUT ZINC	
all	15	01 10749X	NPLT:PULL TO STOP+RESET>ISO	

# Conveyor Bed

## Extractors for Rear Discharge at 20 Degrees

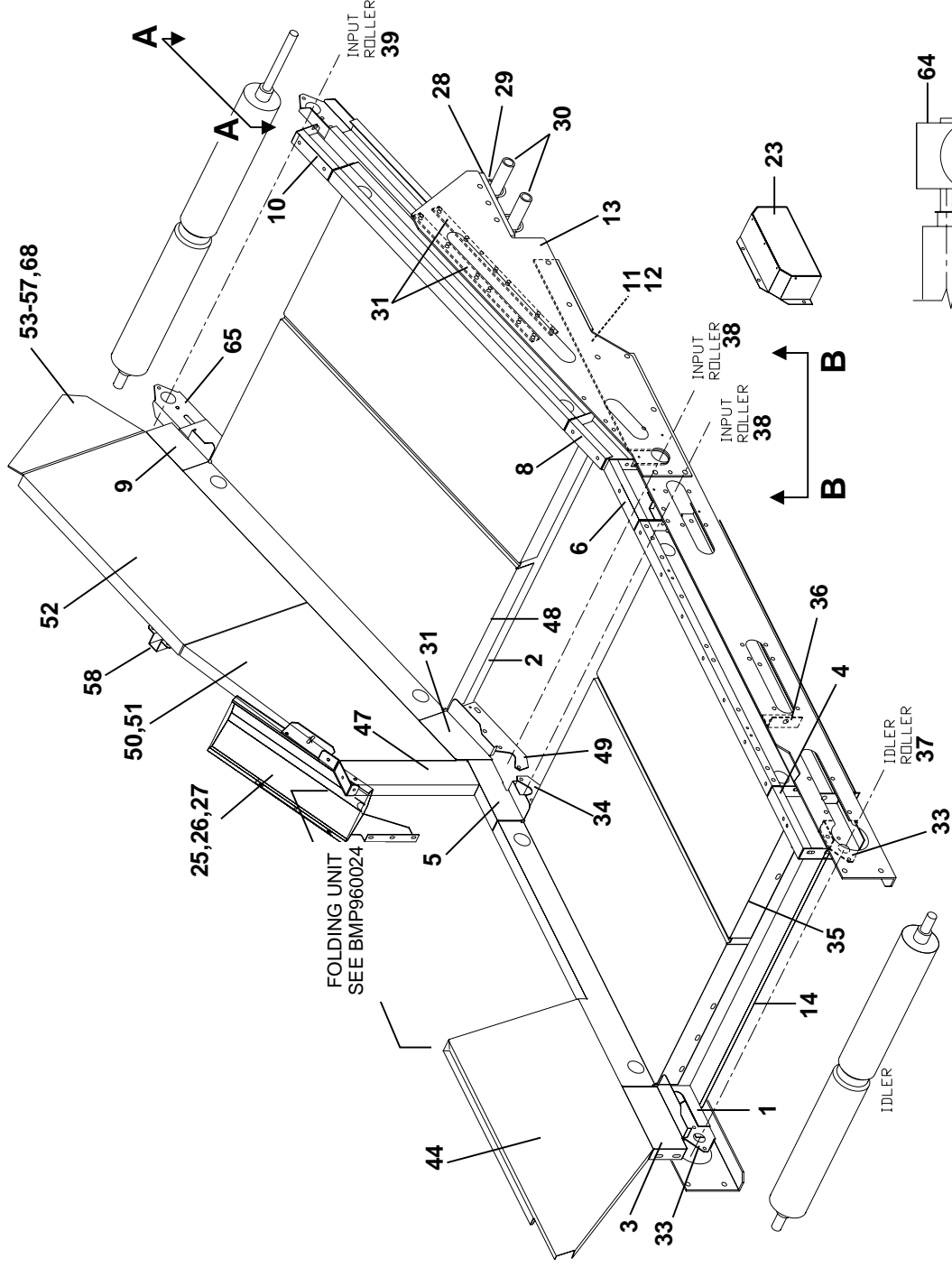
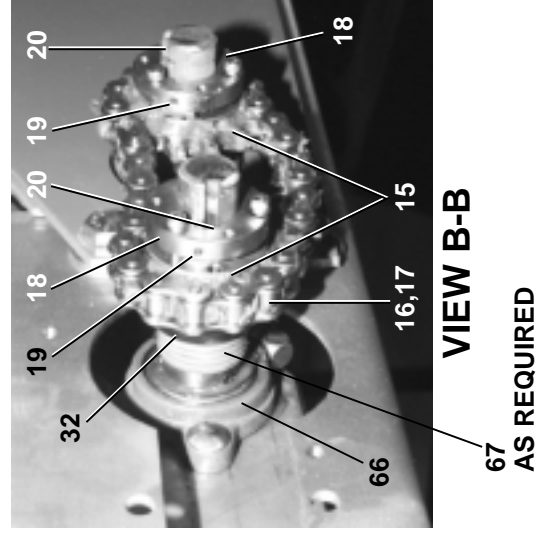
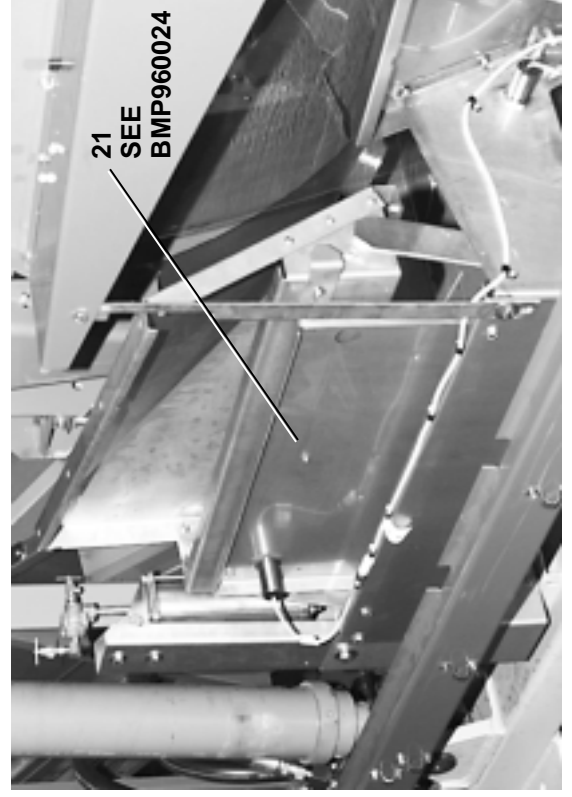
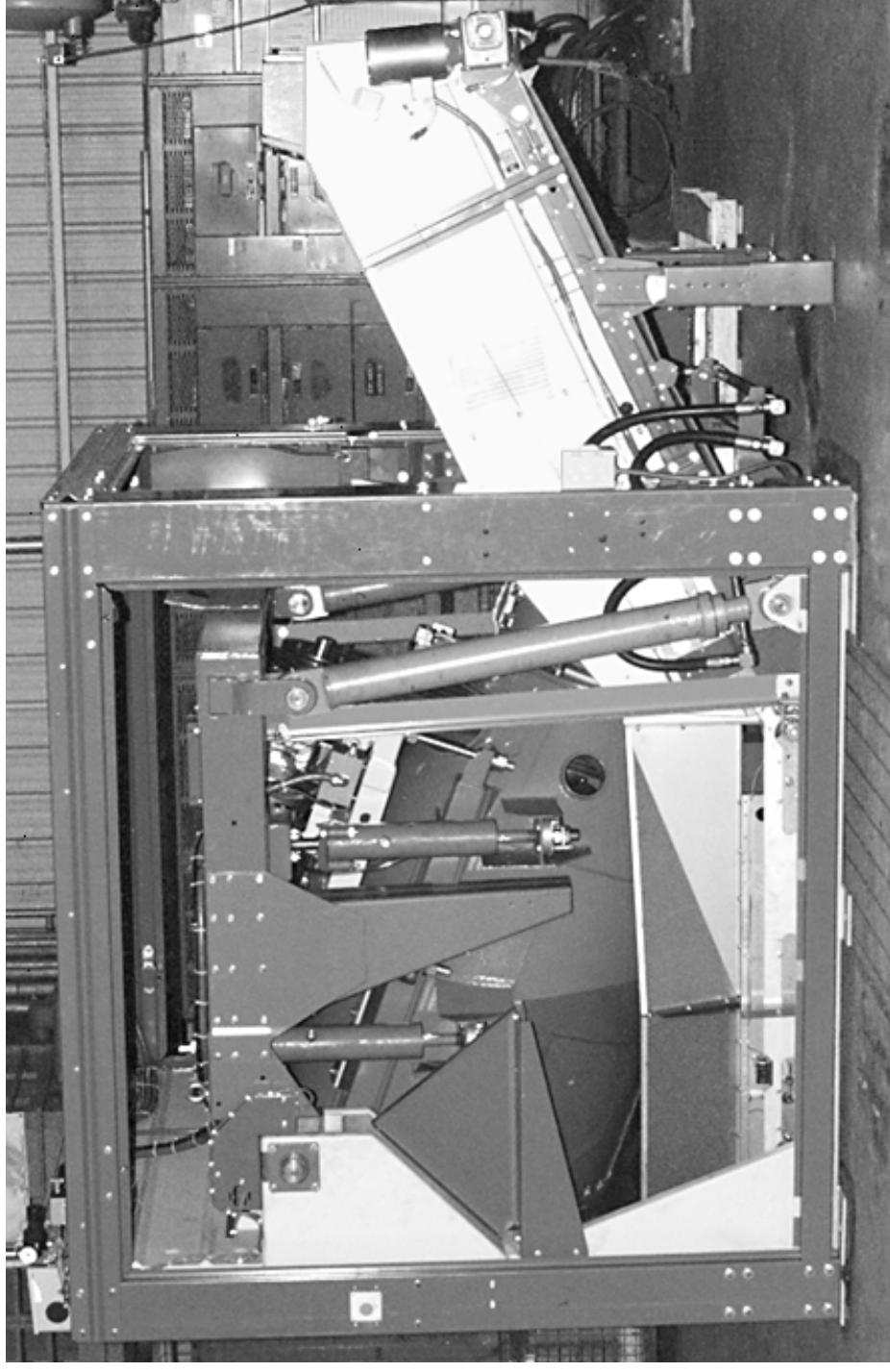


Pellerin Milnor Corporation  
P. O. Box 400, Kenner, LA 70063-0400

BMP960022/96467V (1 of 3)

Litho in U.S.A.

BMP960022/96467V  
(Sheet 1 of 3)



**Conveyor Bed**  
**Extractors for Rear Discharge at 20 Degrees**

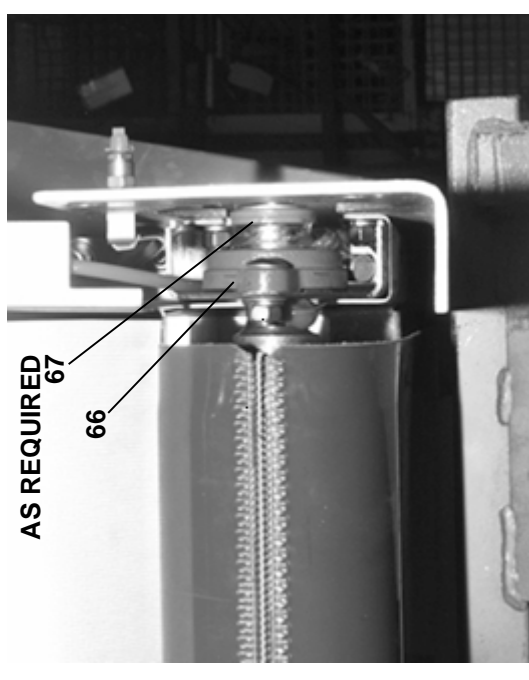
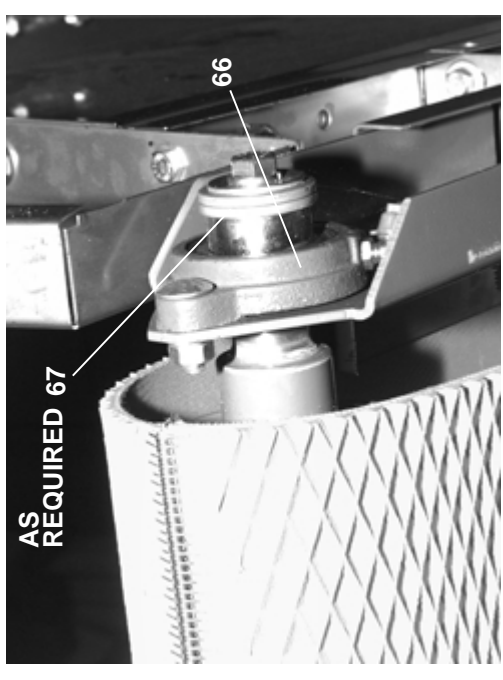
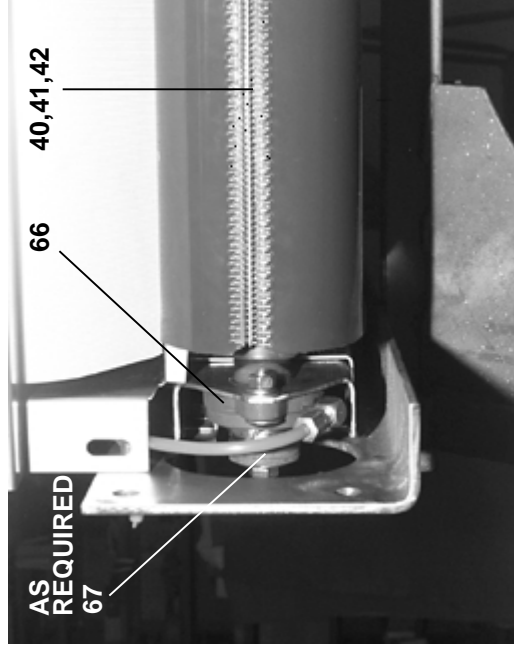
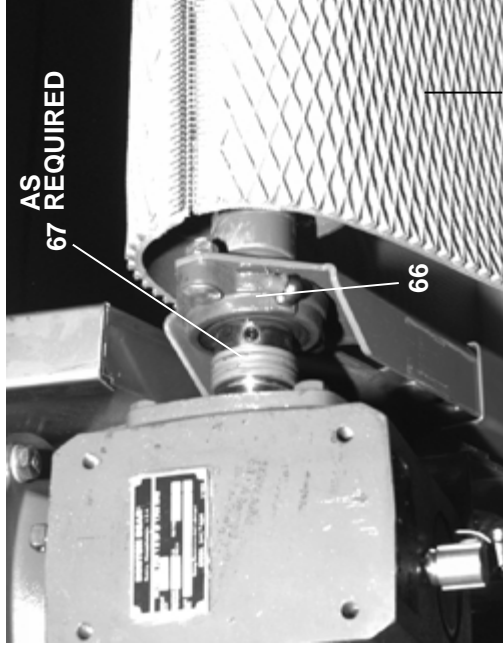
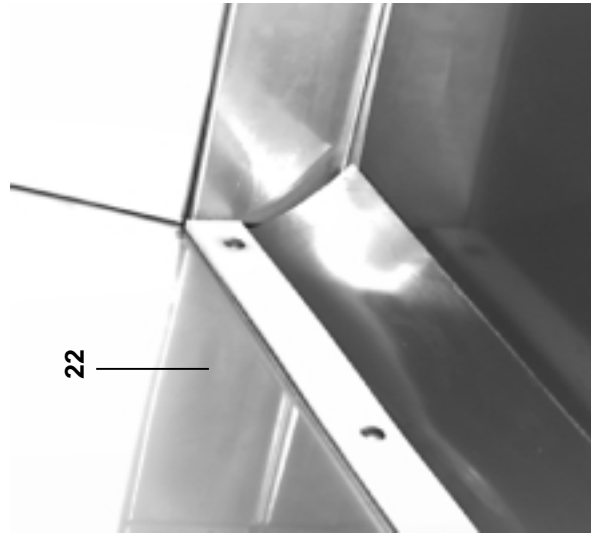


Pellerin Milnor Corporation  
 P. O. Box 400, Kenner, LA 70063-0400

BMP960022/96467V (2 of 3)

Litho in U.S.A.

BMP960022/96467V  
 (Sheet 2 of 3)



**BELT LENGTHS:**

BED TYPE	EXTENSION
HORIZONTAL BED	0"
20 DEGREE INCLINED BED	24"
	48"





**Pellerin Milnor Corporation**  
P. O. Box 400, Kenner, LA 70063-0400

BMP960022/96467V (3 of 3)

BMP960022/96467V  
(Sheet 3 of 3)

Litho in U.S.A.

**Parts List—Conveyor Bed**  
Find the correct assembly first, then find the needed components. The item letters (A, B, C, etc.) assigned to assemblies are referred to in the "Used In" column to identify which components belong to an assembly. The item numbers (1, 2, 3, etc.) assigned to components relate the parts list to the illustration.

Used In	Item	Part Number	Description	Comments
			ASSEMBLIES	
	A	ALC50038	95452Z 20 DEG REAR DISC MTE CONVEY	
	B	ALC500035A	92000Z CONVEY BED-DISC REAR-HORZ	
			COMPONENTS	
all	1	ALC500035A	92000Z CONVEY BED-DISC REAR-HORZ	HORIZONTAL CONVEYOR
all	2	ALC500035B	92000Z CONVEY BED-DISC REAR-20DEG	INCLINED CONVEYOR
all	3	04 22032J	92684C SPACER BLK 20DEG ENDGATE LF	
all	4	04 22032K	92684# SPACER BLK 20DEG ENDGATE RT	
all	5	04 22032L	93396C SPACER BLK 20DEG HORZ MID LF	
all	6	04 22032M	94297C SPACER BLK 20DEG HORZ MID RT	
all	7	04 22032N	94433C SPACER BLK 20DEG INCL MID LF	
all	8	04 22032P	94433# SPACER BLK 20DEG INCL MID RT	
all	9	04 22032Q	94297C SPACER BLK 20DEG DISC END LF	
all	10	04 22032R	94297# SPACER BLK 20DEG DISC END RT	
all	11	04 22033	95337D BED FRAME SUPPORT LF-20DEG	LEFT SIDE
all	12	04 22033A	95337# BED FRAME SUPPORT RT-20DEG	RIGHT SIDE
all	13	04 22034	94291D FRAME SUPPORT - 20 DEG	LEFT OR RIGHT
all	14	04 22019	92487D UNDER BED COVER	
all	15	54N050JA13	SPROCKET M#50JA13SS MTO-NO BUSHING	
all	16	54G050CSS	02Z ROLLCHAIN ANSI 50 SS-1R (5/8"P)	
all	17	54G050SS	01Z CONN LINK ANSI 50SS SPRING CLIP	
all	18	56Q1AJA	1.0" BUSHING M#JA-1-304SS MTO	
all	19	15Q067	SOKSETSCR 10-24X1/4 SS	
all	20	15E210B	SQMACHKEY 1/4X1 NOTAPER-NOHEADC1018	
all	21	ALC500039	92000Z EXT/REAR-UNLOAD FOLDING UNIT	
all	22	ALC500041	93063D REAR-UNLOAD ENDGATE ASSY	
all	23	ALC500040	93061D CHAIN GUARD ASSEMBLY	
all	24	AIC40002	91397B*MCS 46"IDLER ASSY	
all	25	W4 22011	93151D*DRIP PAN WLMT	
all	26	60E010	02Z TUBING 1"X1.312 POLYBRAID *	
all	27	04 22013	92316D DRIP PAN SUPPORT BRKT	
all	28	04 22070A	96127B HYDRAULIC PIPE SUPPORT BRKT	
all	29	27A031	01Z U-BOLT 1" PIPE 5/16-18THD ZINC	
all	30	5N1A52AF82	NPT NIPPLE 1X52 TBE BLKSTL SCH80	
all	31	04 22072	92443B BED FRAME SUPPORT SHIM	
all	32	54JH11000A	01Z SHAFTCOLLAR 1" CLPTYPE CFG#16A	
all	33	04 20801F	92684D BEARING SUPT CONV+4" (S/S)	

**Parts List, cont.—Conveyor Bed**

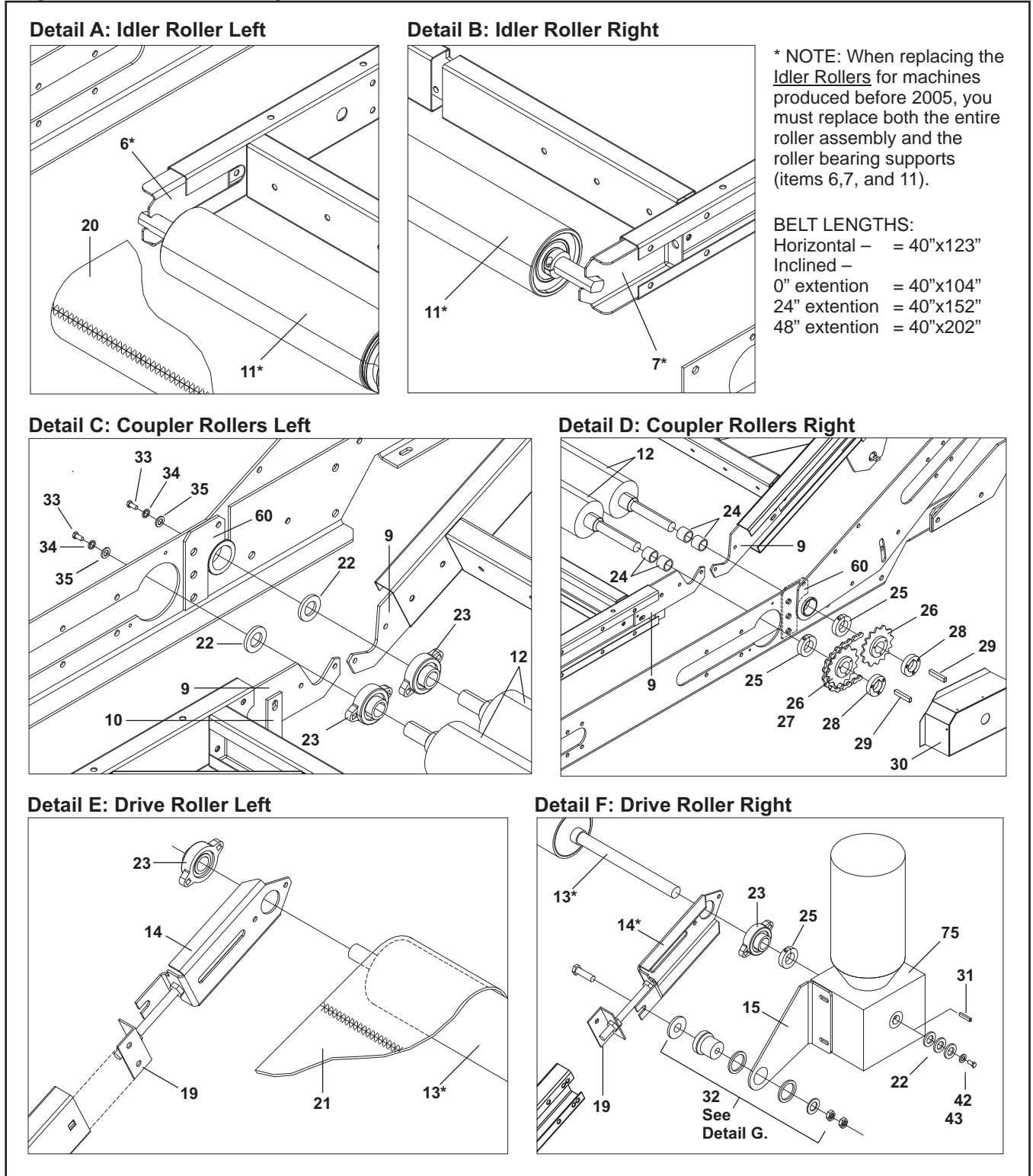
Used In	Item	Part Number	Description	Comments
all	34	04 22908	95133B BRNG SUPP PLATE-5.63 LG	
all	35	04 20804C	92413D CONV BED 41X50 W/NOTCH	
all	36	04 20808A	92684C BEARING ADJ BRKT CONV (S/S)	
all	37	Y4 20833	92176D ROLLER 4X40 GROOVED 1"IDLER	
all	38	Y4 20832B	96471D ROLLER 4"DIA-EXTCONV COUPLER	
all	39	Y4 20832	87461D ROLLER 4X40 GROOVED 1"INPUT	
all	40	54C400	01Z BELT 40" SMOOT TOP W/VEE GUIDE*	SEE CHART FOR BELT LENGTHS
all	41	54G201C	CLIPPER BELT H#UX-1 SP 430SS EA=1BX	
all	42	54G301C	BELT LACER CONN #13 NYL-SS EA.=1FT*	
all	43	04 22062	92316D FLAIRSIDE ENDGATE SUPPORT	
all	44	04 21992	92517D FLAIRSIDE ENDGATE LF	
all	45	04 21992A	92517# FLAIRSIDE ENDGATE RT	
all	46	04 21990	93394D FLAIRSIDE STATIONARY	
all	47	04 21991	92621D SIDE EXT FILLER 3.5L X 15.OH	
all	48	04 20804F	94296D CONV BED 41X50=INCLINE-20DEG	
all	49	04 22907	96407B BRNG SUPP PLATE-9.63 LG	
all	50	04 22030A	93394# SIDE EXT 20DEG INCLINE BED-L	
all	51	04 22030	93394D SIDE EXT 20DEG INCLINE BED-R	
all	52	04 21986B	94297D SIDE EXTENSION 18HX26L	LEFT OR RIGHT
all	53	04 22067	92396D UNLOAD END GUARD MTG-RT	
all	54	04 22067A	92396# UNLOAD END GUARD MTG-LF	
all	55	04 22068	92396D*UNLOAD END GUARD - LF	
all	56	04 22068A	92396#*UNLOAD END GUARD - RT	
all	57	04 22069	92396D UNLOAD END GUARD STRAP	
all	58	04 21988	92487D SIDE EXTENSION SUPPORT BRKT	
all	59	04 20837C	86022C CHAN TORQUE ARM MT 318BOSTON	
all	60	04 20837B	86022C BRKT =TORQUE ARM 318 BOSTON	
all	61	04 20838	82386B TORQUE ARM SUP CONV REAR	
all	62	04 20838A	82386B TORQUE ARM SUPPORT SPACER	
all	63	ALC420063	95452N TORQUE ARM BUSHING ASSEMBLY	
all	64	54STB31830	REDUCER30:1 B#SF718-30T-B5-G .6/1.0	
all	65	04 20801	92302D BRNG SUPPORT CONV	
all	66	54AF10001	FLANGE BRG 1"BROWNING#VF2S-116M	
all	67	15U241MB	FLAT WASHER-1.50D 1+1/32ID 10GA STL	
all	68	04 21653C	93156C FRONT GUARD RETAINING STRIP	
all	69	54C401V	.BELT 40" WEDGEGRIP W/VEE GUIDE	SEE CHART FOR BELT LENGTHS



# Extractor Conveyor - 25° Rear Discharge

M7E4232C, M7V4232C, M9V4232C, MXV4232C, MZV4232C, and MXT4232C

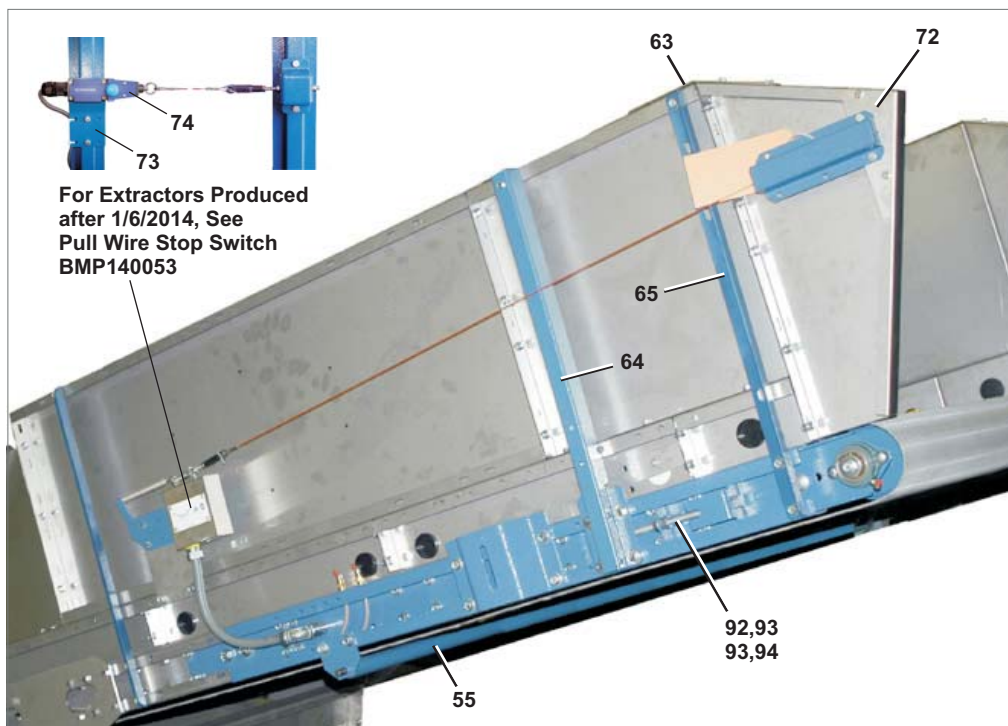
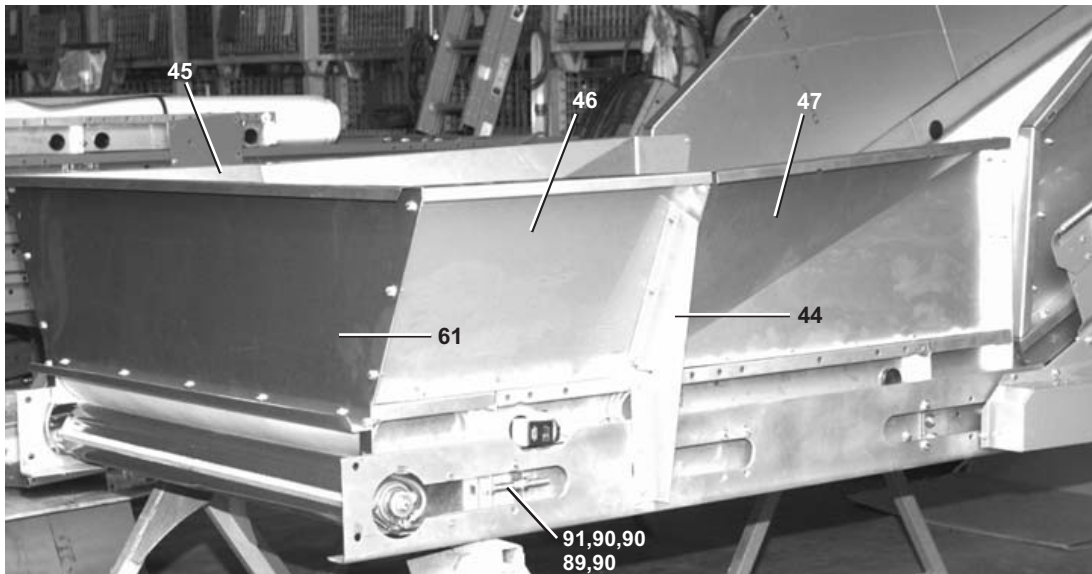
Figure 2: Rollers and Bearings



# Extractor Conveyor - 25° Rear Discharge

M7E4232C, M7V4232C, M9V4232C, MXV4232C, MZV4232C, and MXT4232C

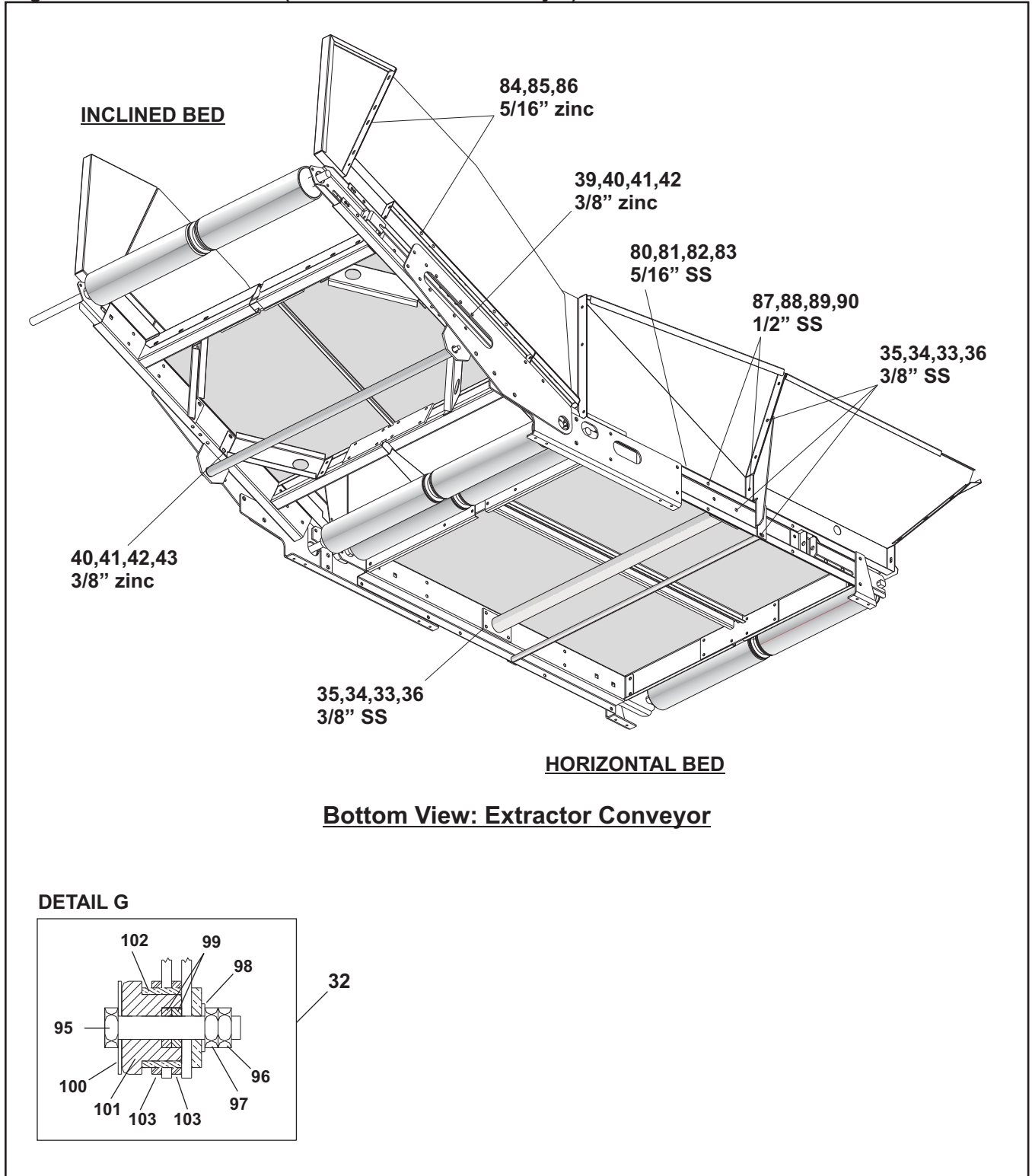
Figure 3: Sides



# Extractor Conveyor - 25° Rear Discharge

M7E4232C, M7V4232C, M9V4232C, MXV4232C, MZV4232C, and MXT4232C

Figure 4: Standard Hardware (shown on MXS4232C conveyor)





# Extractor Conveyor - 25° Rear Discharge

M7E4232C, M7V4232C, M9V4232C, MXV4232C, MZV4232C, and MXT4232C

Find the correct assembly first, then find the needed components. The item letters (A, B, C, etc.) assigned to assemblies are referred to in the "Used In" column to identify which components belong to an assembly. The item numbers (1, 2, 3, etc.) assigned to components relate the parts list to the illustration.

Used In	Item	Part Number	Description	Comments
-----ASSEMBLIES-----				
	A	ALC50062	25 DEG REAR DISC M7E CONVEY	REFERENCE
	B	ALC500035A	CONVEY BED-DISC REAR-HORZ	HORIZONTAL BED
	C	ALC500036	CONVEY BED-DISC REAR-25DEG	INCLINED BED
-----COMPONENTS-----				
all	1	04 20804C	CONV BED 41X50 W/NOTCH	
all	2	04 20802B	CONV SIDE FRAME 4"X45.5 S/S	
all	3	04 20803A	CROSS MBR SECTION CONV (S/S)	
all	4	04 20809S	BED JOINER PLATE S/S	
all	5	04 20810A	CORNER BRACE CONV 4" (S/S)	
all	6	04 20801F	BRNG SUPPORT LOADEND-LF	
all	7	04 20801G	BRNG SUPPORT LOADEND-RT	
B	8	04 20808A	BEARING ADJ BRKT CONV (S/S)	
C	8	04 20808	BRNG ADJ BRKT CONV (COLOR=AZURE BLUE)	
all	9	04 22907	BRG SUPPORT PLATE-9.63 LG	
all	10	04 22909	ROLLER SUPPORT FLATBAR	
all	11	ALC50114A	IDLER ROLLER 35MM BRNG SS-EXTCONV	
all	12	Y4 20832C	EXT-CONV COUPLER ROLLER-MACH	
all	13	Y4 20832E	DRVROLLER 4.50D X 53" OAL	
all	14	04 22131	BRNG SUPPORT UNLOAD END	
all	15	04 22132	TORQARM 25DEG EXTCONV-RT	
all	16	04 20804G	CONV BED 40WX28L GROOVE	
all	17	04 20802K	CONV SIDE FRAME 4"X40"LG	
all	18	04 20803A	CROSS MBR SECTION CONV (S/S)	
all	19	04 20808	BRNG ADJ BRKT CONV	
B	20	54C401000J	BELT 40" X 123" GREEN V-GUIDE W/CLEAT	
C	21	54C401000B	BELT 40" X 104" V-ROUGH TOP	0" EXTENTION
C	21	54C401000C	BELT 40" X 152" V-ROUGH TOP	24" EXTENTION
C	21	54C401000D	BELT 40" X 200" V-ROUGH TOP	48" EXTENTION
all	22	15U241MB	FLAT WASHER-1.50D 1+1/32ID 10G	
all	23	54AF10001	FLG BRG 1" BROWN#VF2S-116M (2BOLT FLG)	
all	24	02 02921H	SPACER=BUSHING LOCKING	
all	25	54JH11000A	SHAFTCOLLAR 1" CLPTYPE CFG#16A	
all	26	54N050JA13	SPRKT MARTIN #50JA13SS MTO-NO BUSH	
all	27	54G050SS28	ROLCHN 5/8P 50SS1R EXTR=28PTCH	
all	28	56Q1AJA	1.0" BUSHING M#JA-1-304SS MTO	
all	29	15E197	1/4X1/4X1SQMACHKEY N0 TAPR/HD	

# Extractor Conveyor - 25° Rear Discharge

M7E4232C, M7V4232C, M9V4232C, MXV4232C, MZV4232C, and MXT4232C

Find the correct assembly first, then find the needed components. The item letters (A, B, C, etc.) assigned to assemblies are referred to in the "Used In" column to identify which components belong to an assembly. The item numbers (1, 2, 3, etc.) assigned to components relate the parts list to the illustration.

Used In	Item	Part Number	Description	Comments
all	30	ALC500040	CHAIN GUARD ASSEMBLY	
all	31	15E227	MACHINE KEY .250X.219X4.50LG	
all	32	ALC420063	TORQUE ARM BUSHING ASSEMBLY	
all	33	15K096	HEXCAPSCR 3/8-16UNC2X1SS18-8	
all	34	15U260	LOCKWASHER MEDIUM 3/8 SS18-8	
all	35	15U245	FLTWASH 3/8 STD COMM 18-8 SS	
all	36	15G206	HEXNUT 3/8-16 UNC2 SS 18-8	
all	37	15K100	HEXCAPSCR 3/8-16X1+1/4 SS18-8	
all	38	15K086	HXCAPSCR 3/8-16NCX3/4 SS18-8	
all	39	15K095	HXCPSCR 3/8-16UNC2AX1 GR5 ZINC	
all	40	15U240	FLATWASHER(USS STD) 3/8" ZNC P	
all	41	15U255	LOCKWASHER MEDIUM 3/8 ZINCPL	
all	42	15G205	HXNUT 3/8-16UNC2B ZINC GR2	
all	43	15K091H	HEXFLGSCR 3/8-16X3/4 ZN GRD.5	
all	44	04 22062	FLAIRSIDE ENDGATE SUPPORT	
all	45	04 21992	FLAIRSIDE ENDGATE LF	
all	46	04 21992A	FLAIRSIDE ENDGATE RT	
all	47	04 21990	FLAIRSIDE STATIONARY	
all	48	04 21991	SIDE EXT FILLER 3.5L X 15.OH	
all	49	04 22133A	SIDE EXT REAR UNLOAD-LF	
all	50	04 22133	SIDE EXT REAR UNLOAD-RT	
all	51	04 22134A	SIDE EXT DISC END-LF	
all	52	04 22134	SIDE EXT DISC END-RT	
all	53	04 22135A	SIDE EXT INCLINE ADP-LF	
all	54	04 22135	SIDE EXT INCLINE ADP-RT	
all	55	AIC40002	COINC 40W IDLER ASSY	
all	56	04 22033B	BED FRAME SUPPORT LF-30DEG	
all	57	04 22033C	BED FRAME SUPPORT RT-30DEG	
all	58	W4 23149A	*BED SUPPORT-LF WLMT 30DEG	
all	59	W4 23149	*BED SUPPORT-RT WLMT 30DEG	
all	60	04 23175	BED SUPT DOUBLER PLATE-25DEG	
all	61	ALC500041	REAR-UNLOAD ENDGATE ASSY	
all	62	04 23150	HYD PIPE SUPPORT PLATE	
all	63	04 21987	SIDE EXTENSION STIFFENER	
all	64	04 21988	SIDE EXTENSION SUPPORT BRKT	

**Extractor Conveyor - 25° Rear Discharge****M7E4232C, M7V4232C, M9V4232C, MXV4232C, MZV4232C, and MXT4232C**

Find the correct assembly first, then find the needed components. The item letters (A, B, C, etc.) assigned to assemblies are referred to in the "Used In" column to identify which components belong to an assembly. The item numbers (1, 2, 3, etc.) assigned to components relate the parts list to the illustration.

Used In	Item	Part Number	Description	Comments
all	65	04 22416	SIDE SUPT BRKT	
all	66	04 22072	BED FRAME SUPPORT SHIM	
all	67	04 22032A	SPACER BLOCK 9"LG-LF	
all	68	04 22032B	SPACER BLOCK 9"LG-RT	
all	69	04 22032C	SPACER BLK 30DEG HORZ MID LF	
all	70	04 22136	SPACER BLOCK 4"X8.56LG-RT	
all	71	04 22137	SPACER BLOCK 4"X7.94LG	
all	72	04 22165	SAFETY WIRE-PULL BRKT-EXTRCONV	
all	73	04 24128	SAFETY SW MTG PLATE-4232M	
all	74	ALC40005E	PULL-WIRE STOP SWITCH ASSY	
all	75	54STB3183R	REDCR30 B#SF718-30T-B5-G +OIL	
all	80	15K052	HXCAPSCR 5/16-18UNC2AX3/4 SS18	
all	81	15U189	FLTWASH 9/32IDX3/40DX.063THK S	
all	82	15U205	LOCKWASHER MEDIUM 5/16" 18-8SS	
all	83	15G186	HEXNUT 5/16-18UNC2 SS18-8	
all	84	15K063	HXCPSC 5/16 18X1 GR8 ZC	
all	85	15U210	LOKWASHER MEDIUM 5/16 ZINCP	
all	86	15U185	FLATWASHER(USS STD) 1/4" ZNC P	
all	87	15K145D	HXCAPSCR 1/2-13UNC2AX3/4 SS18-	
all	88	15U285	FLATWASHER 1/2 STD COMM SS18-8	
all	89	15U310	LOKWASHER REGULAR 1/2 SS18-8	
all	90	15G225	HEXNUT 1/2-13UNC2 SS18-8	
all	91	15K203	HXTAPSCR TFL 1/2-13X5 GR5 ZINC	
all	92	15K205	HXCAPSCR 1/2-13UNC2AX8.5GR5 ZI	
all	93	15G230	HXNUT 1/2-13UNC2B SAE ZINC GR2	
all	94	15G222B	HEXFLGNUT 1/2-13 ZINC SERRATED	
all	95	15K144C	HEXCAPSCR 7/16-14UNC X 2.5 GR	PART OF ITEM 32
all	96	15G222	HXFINJAMNUT 7/16-14UNC2B ZINC	PART OF ITEM 32
all	97	15G222C	HEXNUT 7/16-14UNC2B ZINC GR2	PART OF ITEM 32
all	98	15U271	LOKWASH INTOOTH 7/16ZN	PART OF ITEM 32
all	99	15U312	HARD FWASH 3/4ODX33/64IDX.115	PART OF ITEM 32
all	100	15U202	FLATWSHR.50ID1.75OD11GA ZNC	PART OF ITEM 32
all	101	60B065	RUBBER MNT CTR BONDED 40 DURO	PART OF ITEM 32
all	102	04 20796	SLEEVE=TORQUE ARM BUSHING	PART OF ITEM 32
all	103	02 18571A	PISTON ROD WASHER-.25"TK	PART OF ITEM 32

**Folding Unit**  
**Extractor Conveyors with Rear Discharge**

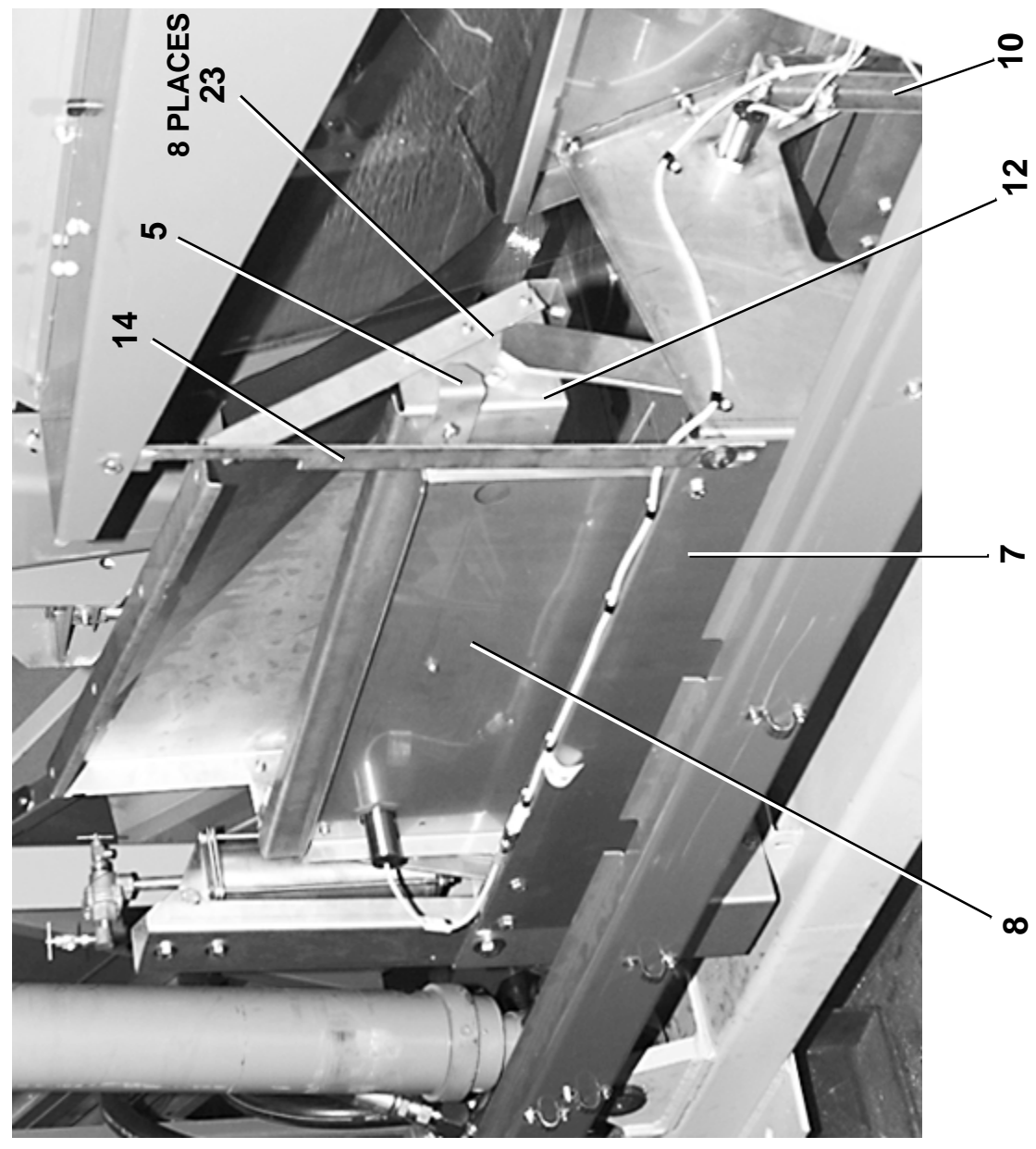
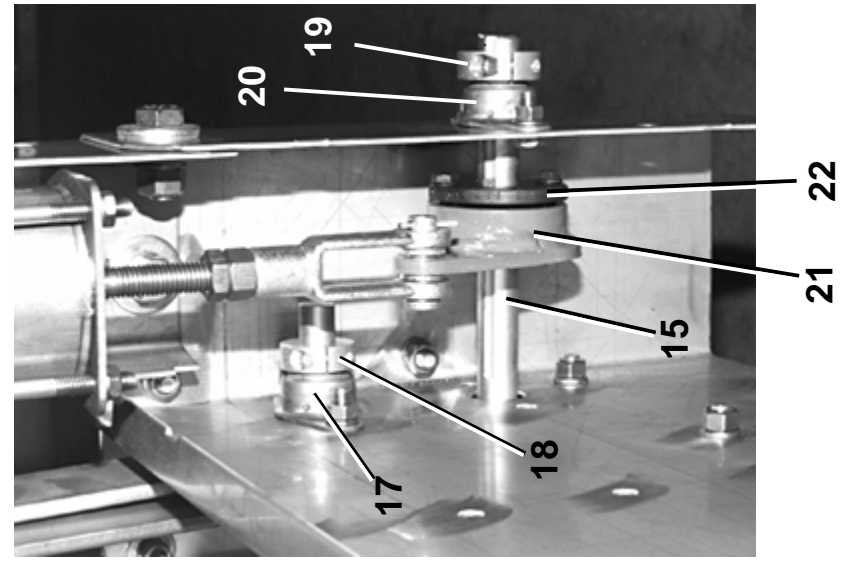
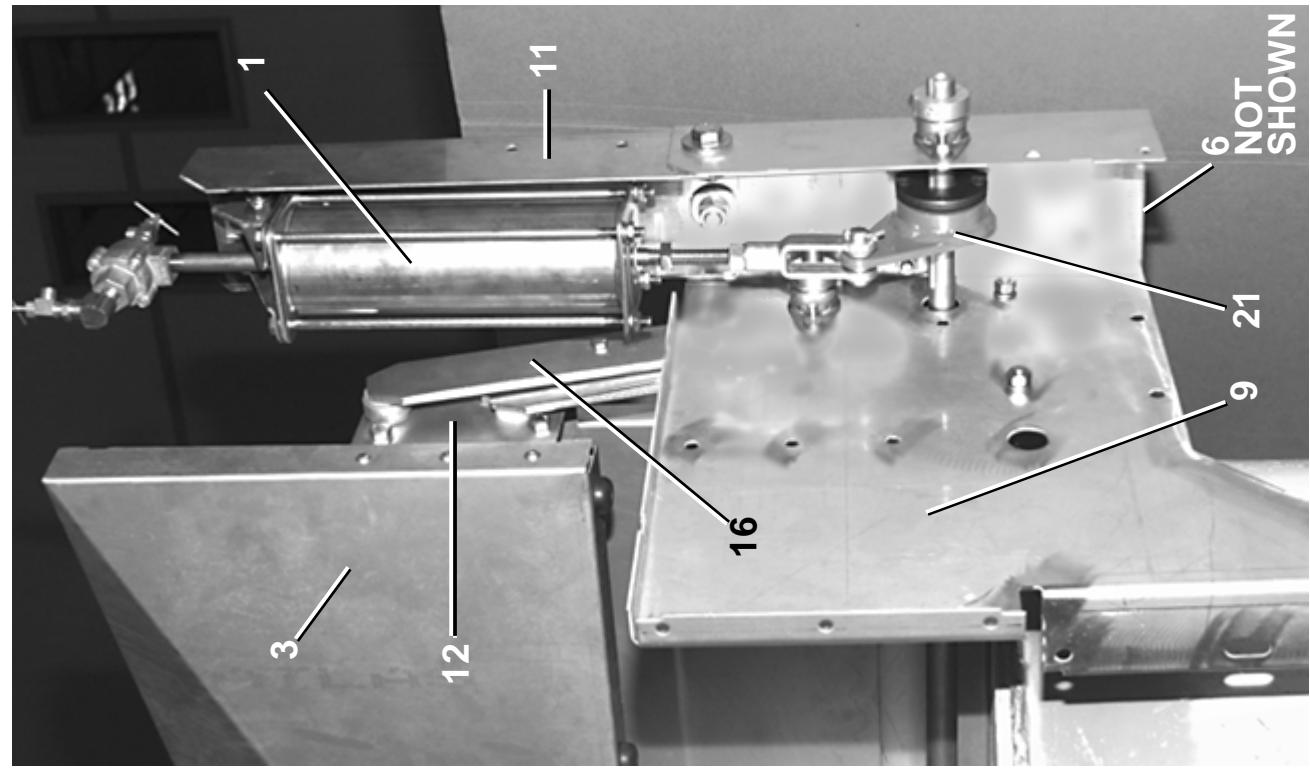
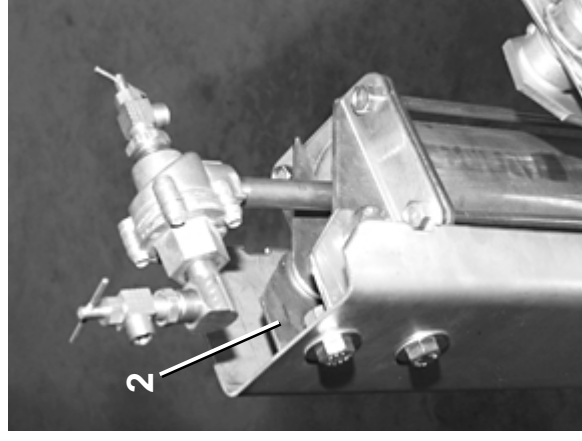
BMP960024/96473V  
 (Sheet 1 of 3)



Pellerin Milnor Corporation  
 P. O. Box 400, Kenner, LA 70063-0400

BMP960024/96473V (1 of 3)

Litho in U.S.A.



**Folding Unit**  
**Extractor Conveyors with Rear Discharge**

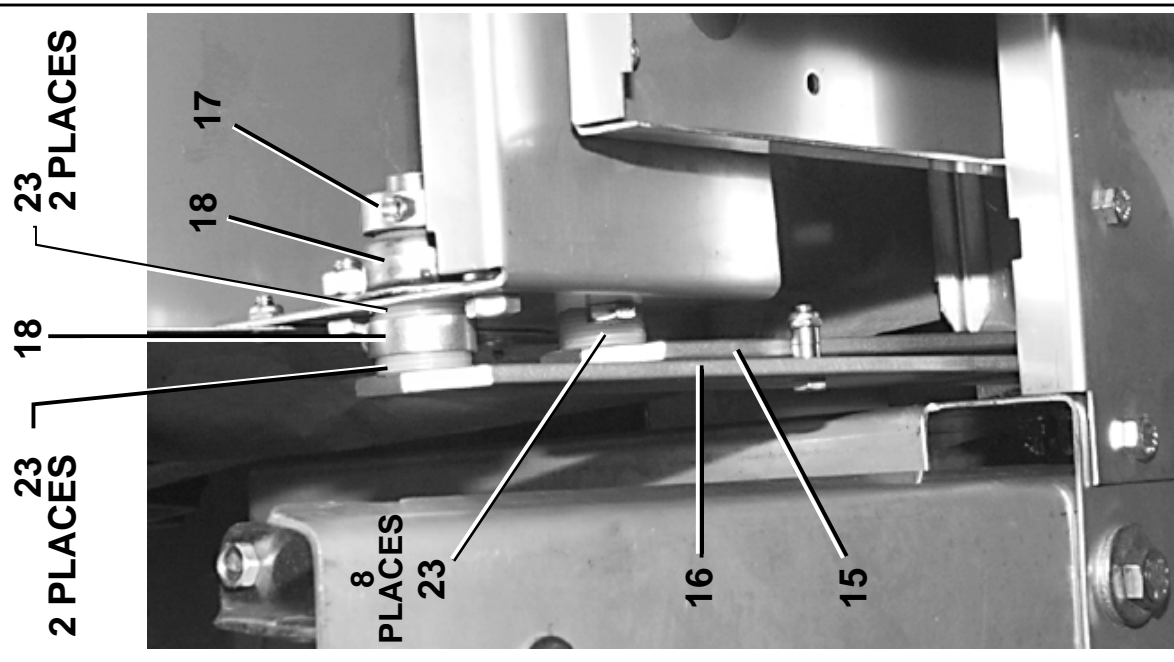
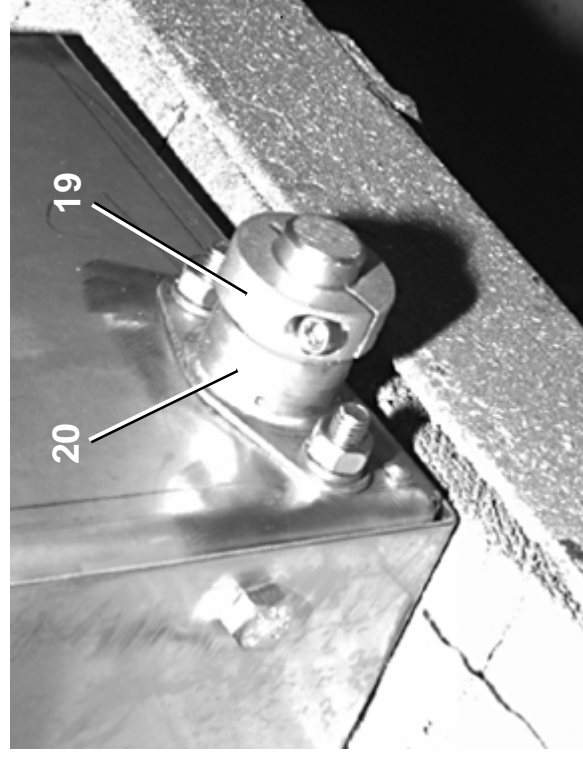
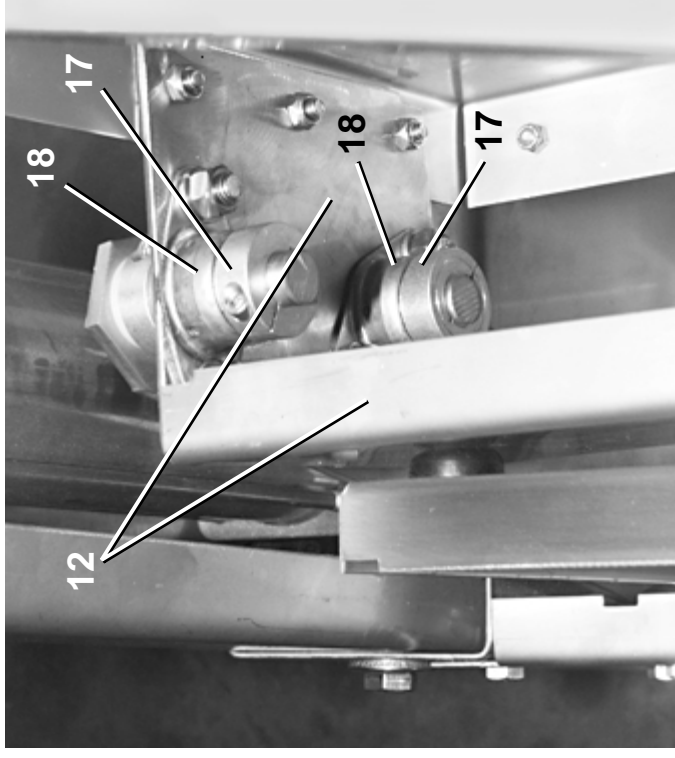
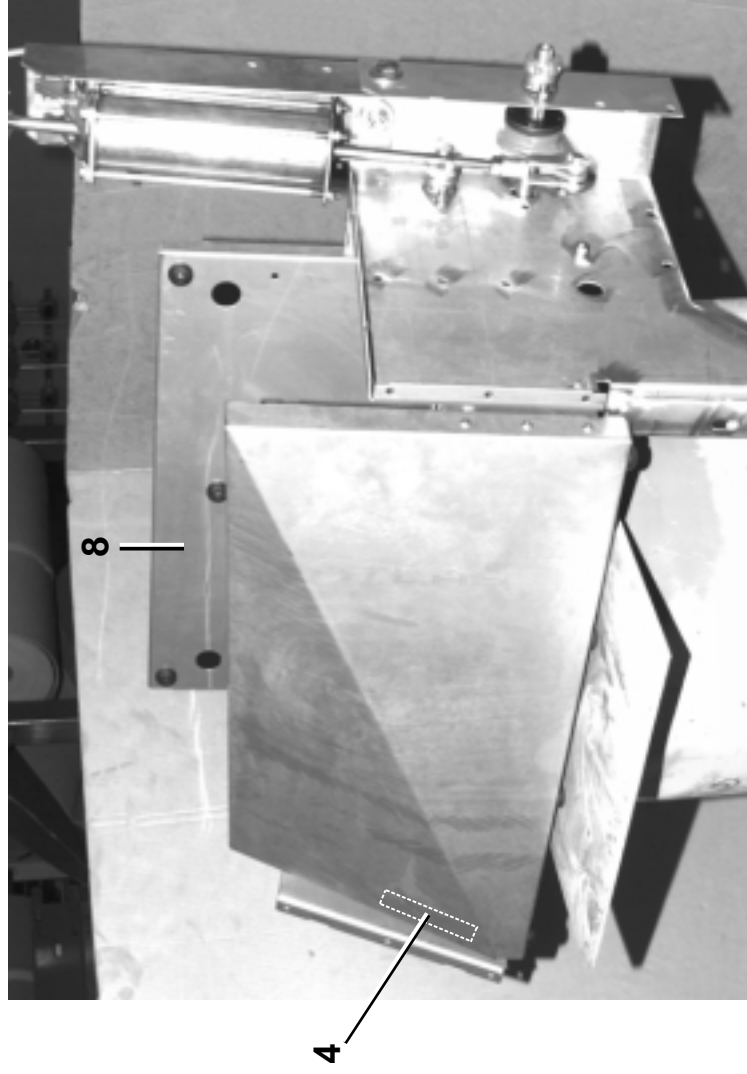
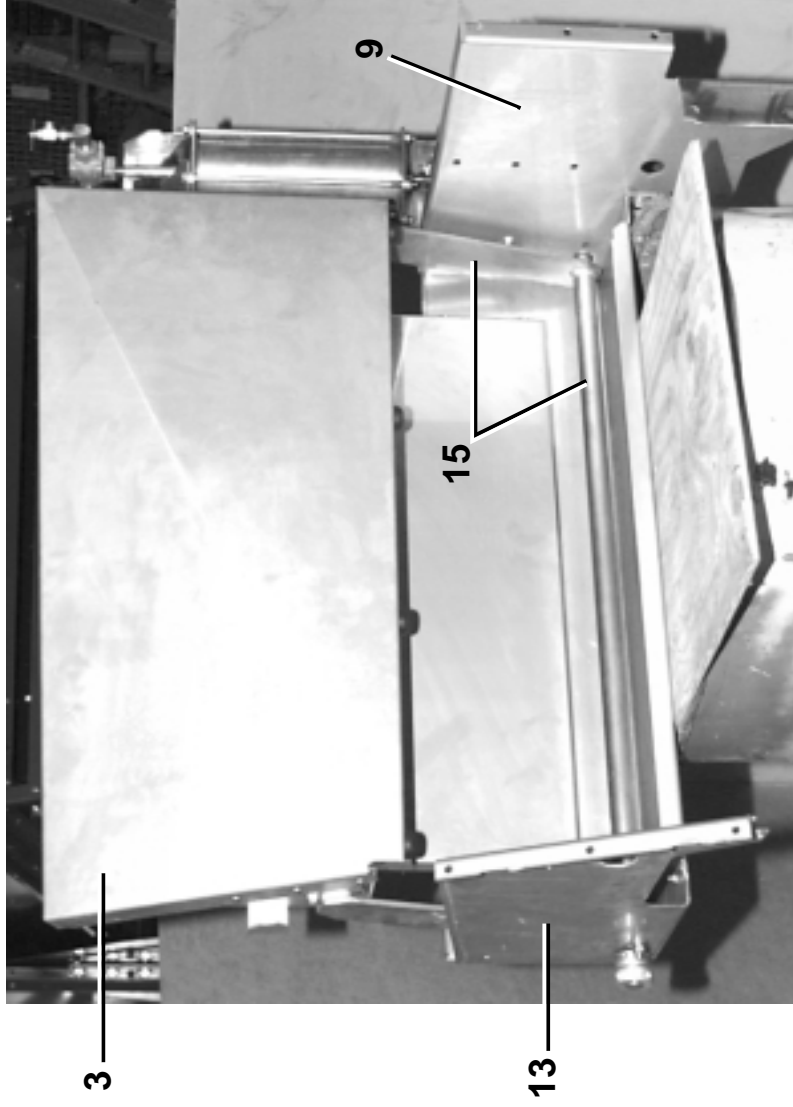
BMP960024/96473V  
 (Sheet 2 of 3)



Pellerin Milnor Corporation  
 P. O. Box 400, Kenner, LA 70063-0400

BMP960024/96473V (2 of 3)

Litho in U.S.A.





Pellerin Milnor Corporation  
P. O. Box 400, Kenner, LA 70063-0400

Litho in U.S.A.

**Parts List—Folding Unit**

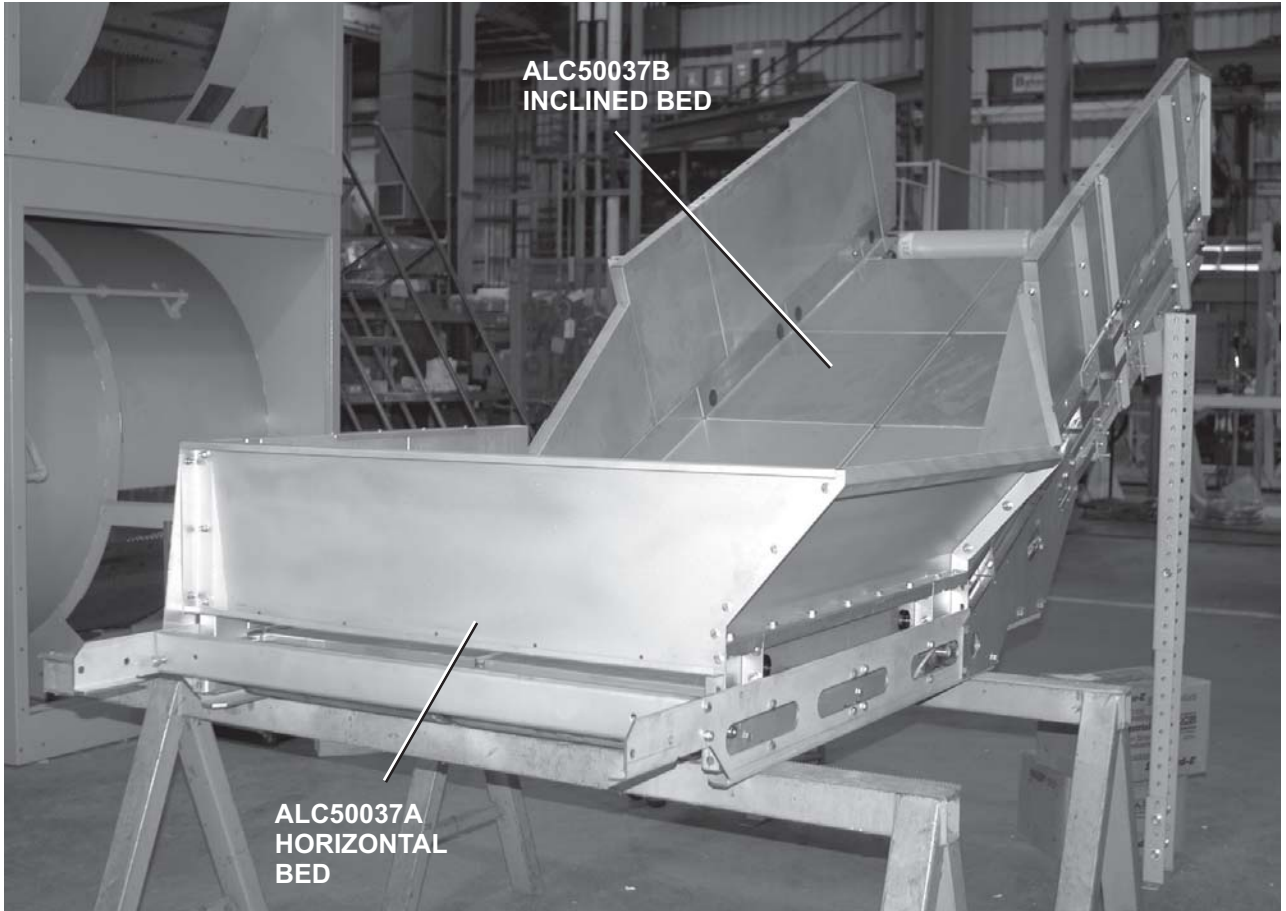
Find the correct assembly first, then find the needed components. The item letters (A, B, C, etc.) assigned to assemblies are referred to in the "Used In" column to identify which components belong to an assembly. The item numbers (1, 2, 3, etc.) assigned to components relate the parts list to the illustration.

Used In	Item	Part Number	Description	Comments
			-----ASSEMBLIES-----	
	A	ALC500039	92000Z EXT/REAR-UNLOAD FOLDING UNIT	
			-----COMPONENTS-----	
all	1	SA 10 057D	95222# AIRCYL=3.0ODX3.89ST171/176SS	
all	2	04 22026A	94162B AIR CYL PIVOT MTG	
all	3	04 21989	94391D FLAIRSIDE FOLDING	
all	4	04 24032	93061B FOLDING SIDE SHIM	
all	5	04 22073	92682B RUNL FOLDING ASSY TARGET	
all	6	03 16284	92413C CONV FOLDSIDE SUPT 42M7E	
all	7	04 22008	93061D FOLDSIDE SIDE SUPPORT	
all	8	04 22009	93313D FOLDSIDE BACK STOP	
all	9	04 22010	93061D FOLDSIDE MAIN SUPPORT	
all	10	04 22025	93061D FOLDSIDE MTG END CHANNEL	
all	11	04 22026	93061D AIR CYLINDER MTG BRKT	
all	12	04 22027	93061D FOLDSIDE MTG BRKT	
all	13	04 22006	95363D FOLDSIDE END SUPPORT	
all	14	04 22128	93142C FOLDING DOOR SUPPORT LEG	
all	15	W4 22060	92517C*FOLDSIDE DRIVE ARM WLMT	
all	16	W4 22061A	93347C*FOLDSIDE IDLER ARM WLMT	
all	17	54JH10625A	01Z SHAFTCOLLAR 5/8 CLPTYPE CFG#10A	
all	18	54E009BM	00Z FLMTBRG 5/8"ALL BRZ T#FL7191	
all	19	54JH10750A	01Z SHAFTCOLLAR 3/4 CLPTYPE CFG#12A	
all	20	54E015BM	00Z FLMTBRG 3/4"ALL BRZ T#FL7190.	
all	21	W7 50678	87016B*LEVER/HUB WELDMENT-L/R FRONT	
all	22	56Q0PH	3/4" BUSHING VPUL TYPE H,D,OR QT	
all	23	15U345B	FLAWSH 101NYL 41/64IDX1.125ODX.062	

# Extractor Conveyor Right

M7V4232R with CEXR4825 Right Discharge and 48" Extension (1997-2016)

Figure 1: General Views



## Extractor Conveyor Right

M7V4232R with CEXR4825 Right Discharge and 48" Extension (1997-2016)

Figure 2: General Views

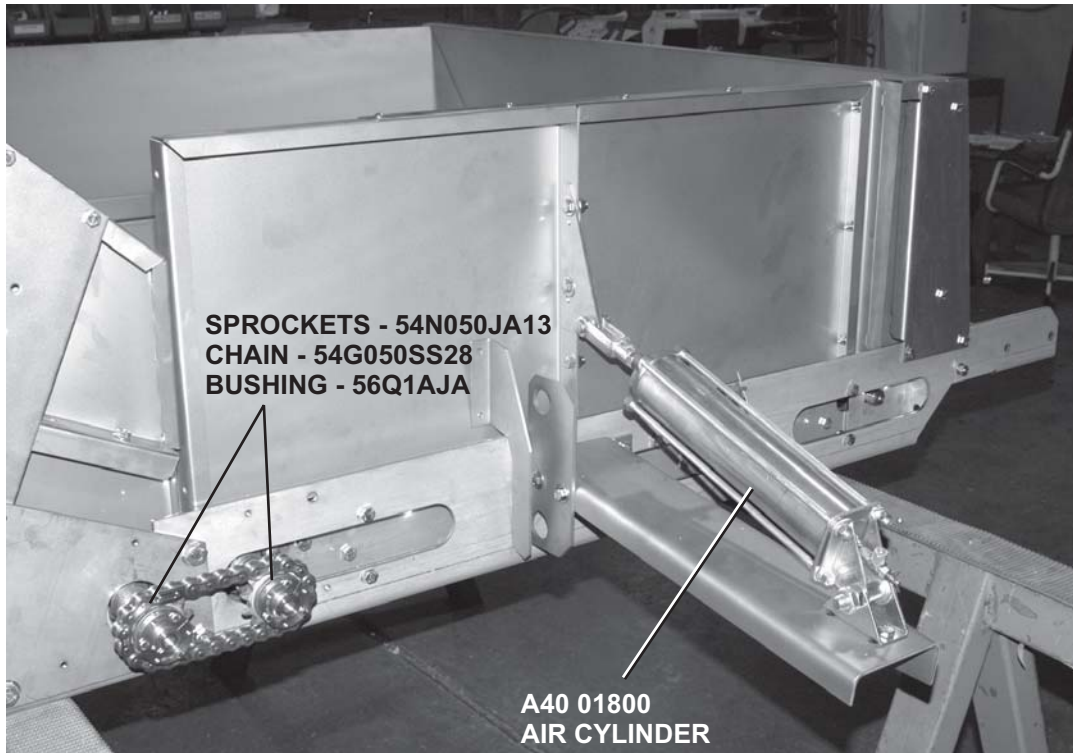
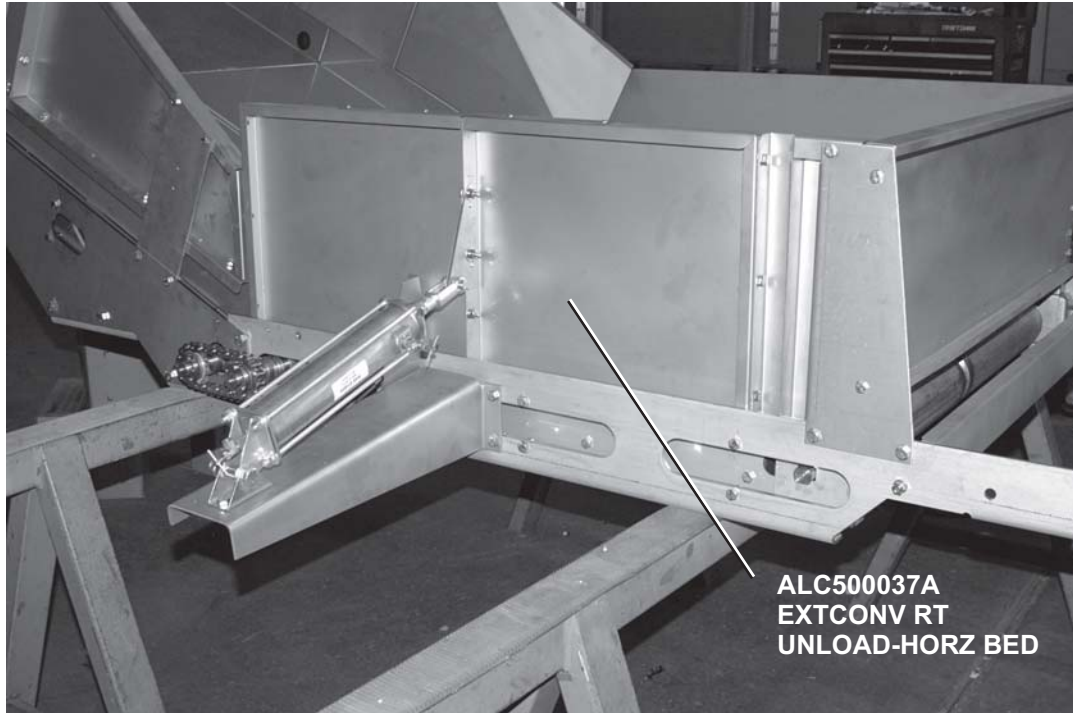




# Extractor Conveyor Right

M7V4232R with CEXR4825 Right Discharge and 48" Extension (1997-2016)

Figure 3: Folding Door



# Extractor Conveyor Right

M7V4232R with CEXR4825 Right Discharge and 48" Extention (1997-2016)

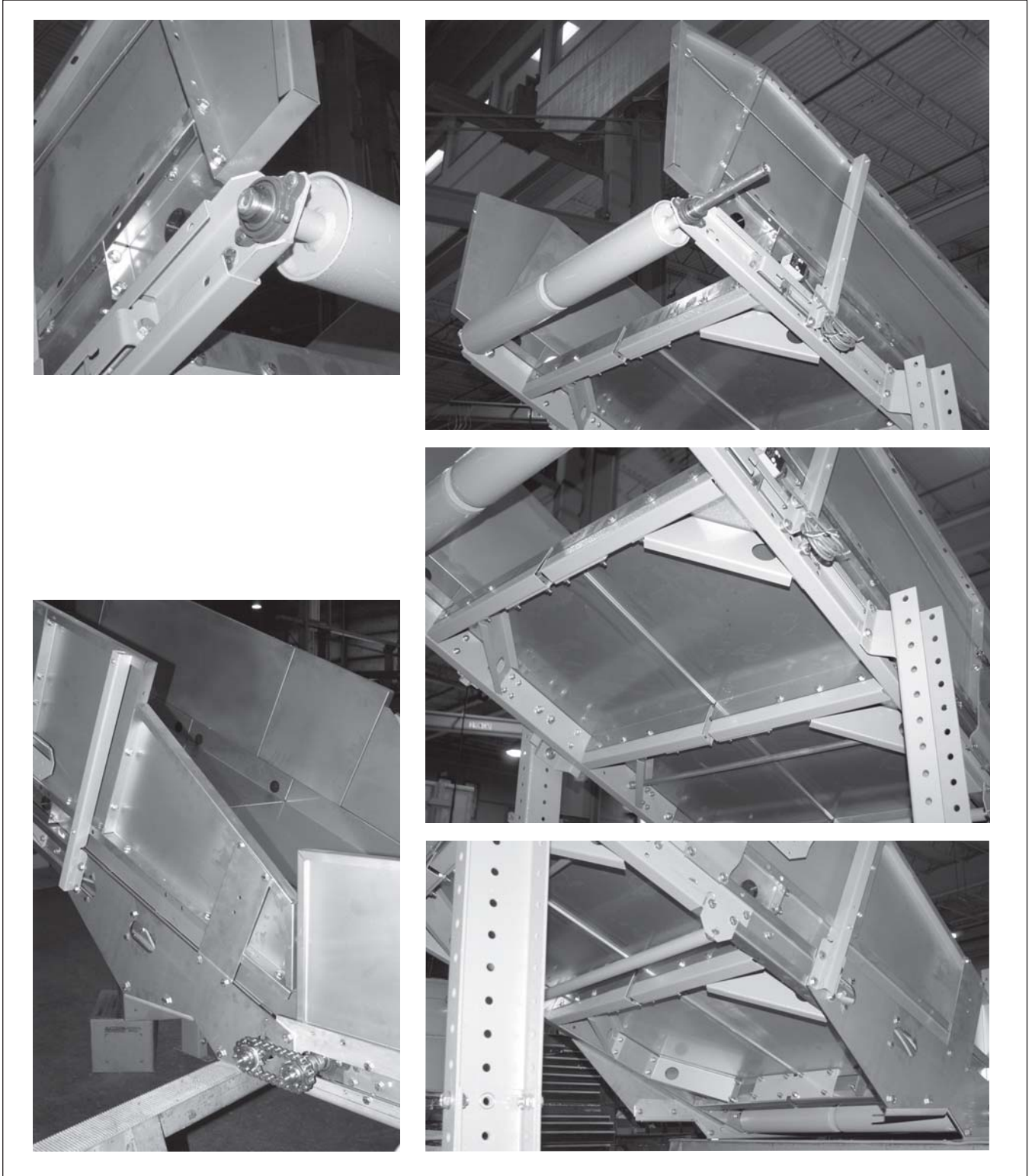
Figure 4: General Views



# Extractor Conveyor Right

M7V4232R with CEXR4825 Right Discharge and 48" Extension (1997-2016)

Figure 5: General Views



## Extractor Conveyor Right

M7V4232R with CEXR4825 Right Discharge and 48" Extention (1997-2016)

Figure 6: General Views



# Extractor Conveyor Right

M7V4232R with CEXR4825 Right Discharge and 48" Extention (1997-2016)

Parts List—Extractor Conveyor Right				
Find the correct assembly first, then find the needed components. The item letters (A, B, C, etc.) assigned to assemblies are referred to in the "Used In" column to identify which components belong to an assembly. The item numbers (1, 2, 3, etc.) assigned to components relate the parts list to the illustration.				
Used In	Item	Part Number	Description	Comments
-----ENTIRE CONVEYOR-----				
	A	ALC50041	25 DEG RIGHT DISC M7E CONVEY	REFERENCE ASSEMBLY
-----COMPONENTS-----				
all	10	15K052	HXCAPSCR 5/16-18UNC2AX3/4 SS18	
all	20	15U201	FLATWASH 7/80DX3/8IDX.062THK S	
all	30	15U205	LOCKWASHER MEDIUM 5/16" 18-8SS	
all	40	15G186	HEXNUT 5/16-18UNC2 SS18-8	
all	50	15K095	HXCPSCR 3/8-16UNC2AX1 GR5 ZINC	
all	60	15U240	FLATWASHER(USS STD) 3/8" ZNC P	
all	70	15G205	HXNUT 3/8-16UNC2B ZINC GR2	
all	80	15K153	HXCAPSCR 1/2 -13 X 1 +1/4 SS	
all	90	15U310	LOKWASHER REGULAR 1/2 SS18-8	
all	100	15G225	HEXNUT 1/2-13UNC2 SS18-8	
all	110	15N186	HXCAPSCR 1/4-20X3/4 SS18-8	
all	120	15U181	LOCKWASHER MEDIUM 1/4 SS18-8	
all	130	ALC500037A	EXTCONV RT UNLOAD-HORZ BED	
all	140	ALC500037B	EXTCONV RT UNLOAD-25DEG BED	
all	150	54STB31830	REDUCER 30:1 SF718-30T-B5-G	
all	160	15E227	MACHINE KEY .250X.219X4.50LG	
all	180	04 22132A	TORQARM 25DEG EXTCNV-LF	
all	220	ALC420063	TORQUE ARM BUSHING ASSEMBLY	
all	230	54C401000H	BELT 40W V-SMTH TOP-88"LG	
all	280	12P11PHP	HOLEPLUG 1+3/4" BLK HEYCO#2773	
all	290	A40 01800	* AIRCYL,2-WAY =52DRYELL	
all	300	54N050JA13	SPRKT M#50JA13SS MTO-NO BUSH	
all	310	54G050SS28	ROLCHN 5/8P 50SS1R EXTR=28PTCH	
all	330	56Q1AJA	1.0" BUSHING M#JA-1-304SS MTO	
all	340	15Q067	SOKSETSCR 10-24X1/4 SS	
all	350	15E197	1/4X1/4X1SQMACHKEY N0 TAPR/HD	
all	355	02 02921H	SPACER=BUSHING LOCKING	
all	360	ALC500040	CHAIN GUARD ASSEMBLY	
all	370	AIC40002	*MCS 42W IDLER ASSY	
all	380	54JH11000A	SHAFTCOLLAR 1" CLPTYPE CFG#16A	
-----HORIZONTAL BED ASSEMBLY-----				
	B	ALC500037A	EXTCONV RT UNLOAD-HORZ BED	HORIZONTAL BED
-----COMPONENTS-----				
B	10	15K052	HXCAPSCR 5/16-18UNC2AX3/4 SS18	
B	20	15U201	FLATWASH 7/80DX3/8IDX.062THK S	
B	30	15U205	LOCKWASHER MEDIUM 5/16" 18-8SS	
B	40	15G186	HEXNUT 5/16-18UNC2 SS18-8	
B	50	15K096	HEXCAPSCR 3/8-16UNC2X1SS18-8	
B	60	15K100	HEXCAPSCR 3/8-16X1+1/4 SS18-8	
B	70	15U245	FLTWASH 3/8 STD COMM 18-8 SS	
B	80	15U260	LOCKWASHER MEDIUM 3/8 SS18-8	
B	90	15G206	HEXNUT 3/8-16 UNC2 SS 18-8	
B	100	15K203	HXTAPSCR TFL 1/2-13X5 GR5 ZINC	
B	110	15U310	LOKWASHER REGULAR 1/2 SS18-8	
B	120	15G225	HEXNUT 1/2-13UNC2 SS18-8	
B	130	15K063	HXCPCS 5/16 18X1 GR8 ZC	
B	140	04 22403	BED SUPPORT PLATE - LF	
B	150	04 22403A	BED SUPPORT PLATE - RT	
B	160	04 22402	CONV SIDE FRAME 4"X37.5 S/S	
B	170	04 20803A	CROSS MBR SECTION CONV (S/S)	

# Extractor Conveyor Right

M7V4232R with CEXR4825 Right Discharge and 48" Extention (1997-2016)

<b>Parts List—Extractor Conveyor Right</b>				
Find the correct assembly first, then find the needed components. The item letters (A, B, C, etc.) assigned to assemblies are referred to in the "Used In" column to identify which components belong to an assembly. The item numbers (1, 2, 3, etc.) assigned to components relate the parts list to the illustration.				
Used In	Item	Part Number	Description	Comments
B	180	04 20809	JOINER PLATE CONV	
B	190	04 20810A	CORNER BRACE CONV 4" (S/S)	
B	200	04 20808A	BEARING ADJ BRKT CONV (S/S)	
B	210	04 20804D	CONV BED/SIDE UNLOAD W/NOTCH	
B	220	Y4 20832C	EXT-CONV COUPLER ROLLER-MACH	
B	230	ALC50114	SS IDLER ROLLER ASSY-EXTCONV	
B	240	54AF10001	FLG BRG 1" BROWN#VF2S-116M	
B	241	15U241MB	FLAT WASHER-1.50D 1+1/32ID 10G	
B	242	54JH11000S	SHAFTCOLLAR SPLIT 1" STAINLESS	
B	250	15K063	HXCPSC 5/16 18X1 GR8 ZC	
B	260	15U210	LOKWASHER MEDIUM 5/16 ZINCPL	
B	270	15G185	HXNUT 5/16-18UNC2B SAE ZINC GR	
B	280	04 22411	RT UNLOAD FLAIRSIDE-HORZ BED	
B	290	04 22412	SIDE UNLOAD ENDGATE	
B	300	04 22413	AIR CYL MTG BRKT	
B	310	04 22414	FOLDING DOOR - REAR	
B	320	04 22415	FOLDING DOOR - FORWARD	
B	330	04 22414A	FOLDING SIDE EXTENSION-1.5	
B	340	04 22422	ENDGATE SUPT	
B	350	04 22400	CROSS BRACE REAR	
B	360	04 22421	UNDER BED COVER-SIDE UNLOAD	
B	370	04 22424	FOLDING DOOR PROX SW MTG	
B	380	04 22425	FOLDING DOOR TARGET-RT UNLOD	
B	390	04 22423	HINGE SPACER STRIP	
B	400	04 20801H	BRNG SUPT REAR/SIDE UNL(S/S)	
B	410	04 22908	BRG SUPPORT PLATE-5.63 LG	
B	420	04 22407	AIRCYL SUPT ARM-RT UNLOAD	
B	430	04 22030P	ENDGATE SIDE EXT-RT UNLOAD	
B	440	04 22030C	SPACER BLK-RT UNL-REAR RT	
B	450	04 22030D	SPACER BLK-RT UNL-HORZMIDRT	
B	460	04 22030E	SPACER BLK-RT UNL-HORZMIDLF	
B	470	04 21473	STONEGUARD FLAP HINGE-35.5	
-----INCLINED BED ASSEMBLY-----				
	C	ALC500037B	EXTCONV RT UNLOAD-25DEG BED	INCLINED BED
-----COMPONENTS-----				
C	10	15K052	HXCAPSCR 5/16-18UNC2AX3/4 SS18	
C	20	15U201	FLATWASH 7/80DX3/8IDX.062THK S	
C	30	15U205	LOCKWASHER MEDIUM 5/16" 18-8SS	
C	40	15G186	HEXNUT 5/16-18UNC2 SS18-8	
C	50	15K096	HEXCAPSCR 3/8-16UNC2X1SS18-8	
C	60	15U245	FLTWASH 3/8 STD COMM 18-8 SS	
C	70	15U260	LOCKWASHER MEDIUM 3/8 SS18-8	
C	80	15G206	HEXNUT 3/8-16 UNC2 SS 18-8	
C	90	15K203	HXTAPSCR TFL 1/2-13X5 GR5 ZINC	
C	100	15U310	LOKWASHER REGULAR 1/2 SS18-8	
C	110	15G225	HEXNUT 1/2-13UNC2 SS18-8	
C	120	15K063	HXCPSC 5/16 18X1 GR8 ZC	
C	130	04 22404	BED SUPT INCL SIDE DISCHARGE	
C	140	04 22072	BED FRAME SUPPORT SHIM	
C	150	04 20802K	CONV SIDE FRAME 4"X40"LG	
C	160	04 20803A	CROSS MBR SECTION CONV (S/S)	
C	170	04 20804G	CONV BED 40WX28L GROOVE	
C	180	04 20808	BRNG ADJ BRKT CONV	
C	190	04 20809	JOINER PLATE CONV	

# Extractor Conveyor Right

M7V4232R with CEXR4825 Right Discharge and 48" Extention (1997-2016)

## Parts List—Extractor Conveyor Right

Find the correct assembly first, then find the needed components. The item letters (A, B, C, etc.) assigned to assemblies are referred to in the "Used In" column to identify which components belong to an assembly. The item numbers (1, 2, 3, etc.) assigned to components relate the parts list to the illustration.

Used In	Item	Part Number	Description	Comments
C	200	04 20810A	CORNER BRACE CONV 4" (S/S)	
C	210	Y4 20832E	DRVROLLER 4.50D X 53" OAL	
C	220	Y4 20832C	EXT-CONV COUPLER ROLLER-MACH	
C	230	04 22131	BRNG SUPPORT UNLOAD END	
C	240	04 22907	BRG SUPPORT PLATE-9.63 LG	
C	250	54AF10001	FLG BRG 1" BROWN#VF2S-116M	
C	251	15U241MB	FLAT WASHER-1.50D 1+1/32ID 10G	
C	252	54JH11000S	SHAFTCOLLAR SPLIT 1" STAINLESS	
C	260	15K063	HXCPSC 5/16 18X1 GR8 ZC	
C	270	15U210	LOKWASHER MEDIUM 5/16 ZINCPL	
C	280	15G185	HXNUT 5/16-18UNC2B SAE ZINC GR	
C	290	04 22417	SIDE TRANSITION LEFT	
C	300	04 22418	SIDE TRANSITION RT	
C	310	04 22164	SIDE 18"X17.32"LG CEXR0025-RT	
C	320	04 22164A	SIDE 18"X17.32"LG CEXR0025-LF	
C	321	04 22134	SIDE EXT DISC END-RT	
C	322	04 22134A	SIDE EXT DISC END-LF	
C	330	04 22426	SIDE SUPT/SWITCH MOUNT	
C	340	04 22416	SIDE SUPT BRKT	
C	341	04 21988	SIDE EXTENSION SUPPORT BRKT	
C	342	04 21900	CONWA SIDE SUPPORT CLAMP	
C	343	15P149	1/4-14X3/4 SCRSELFDRIL+TAP ZC	
C	350	04 22161	BED SPACER CEXR0025 INCLBED-LF	
C	360	04 22162A	BED SPACER CEXR0025 INCLBED-RT	
C	370	04 22137	SPACER BLOCK 4"X7.94LG	
C	390	04 22428	SIDE SUPP-MOTOR SIDE RT-UNLO	
C	400	04 24128	SAFETY SW MTG PLATE-4232M	





# Water and Steam Piping and Assemblies

9

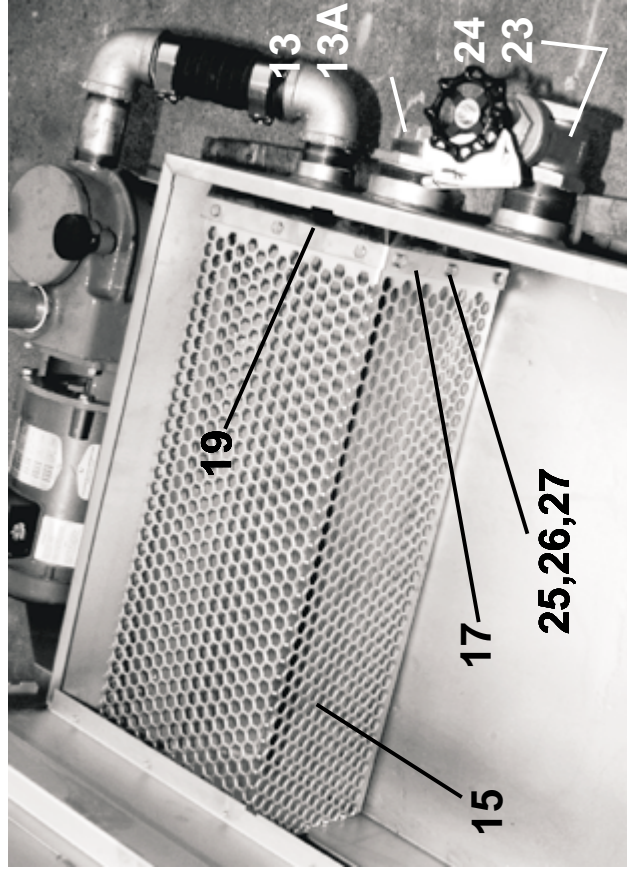
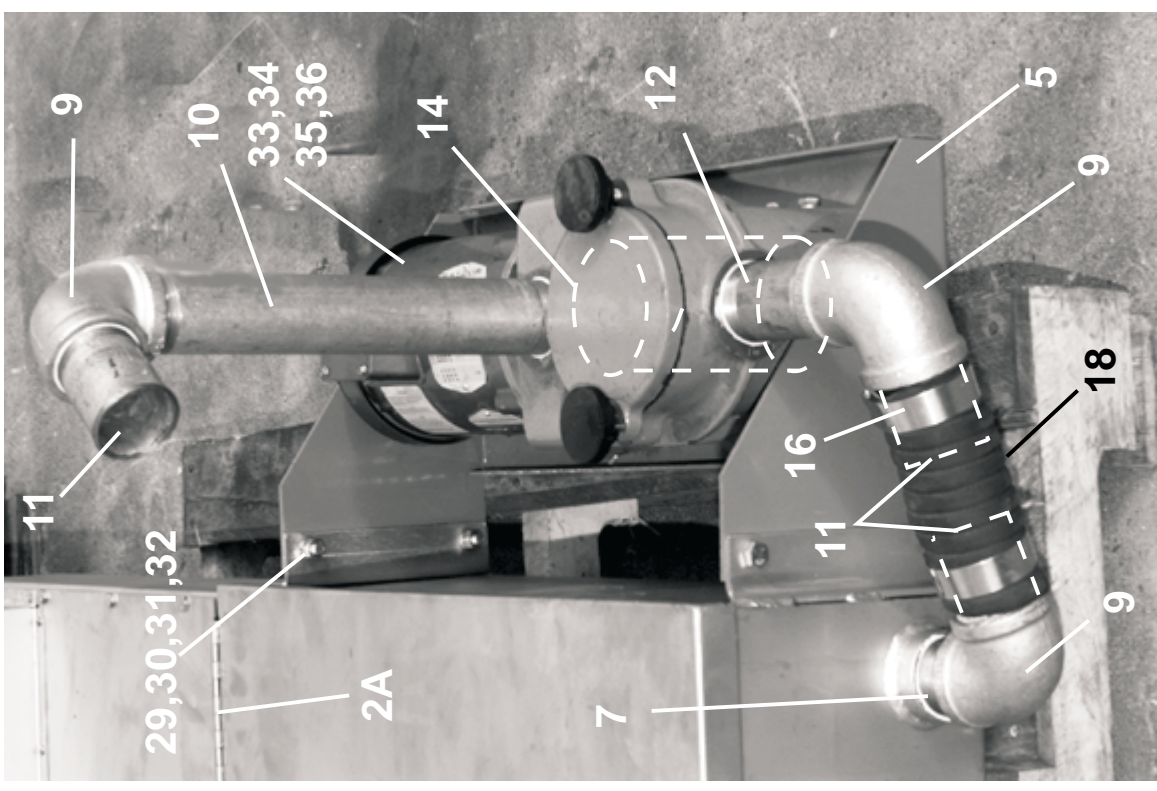
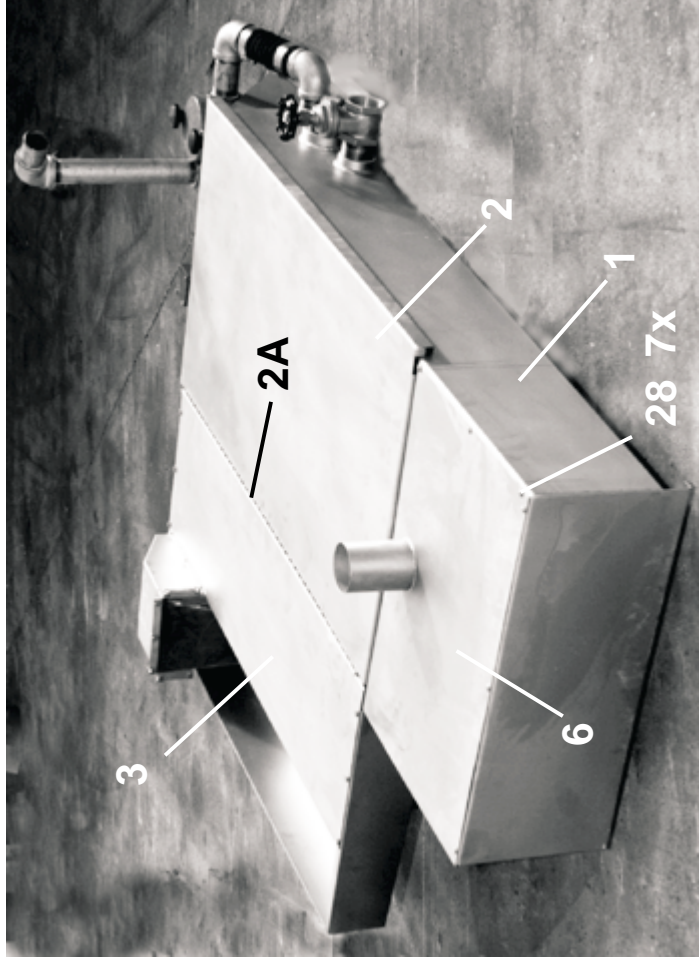
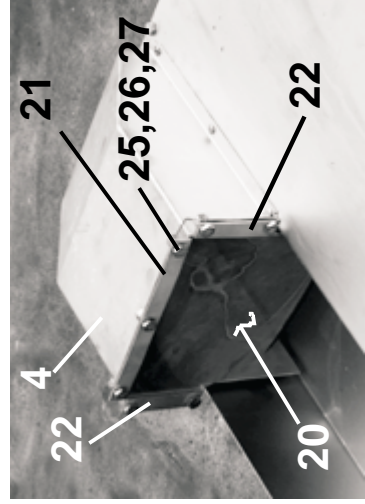
**Reuse Tank Assembly**  
**M7E4232C,L,R M7V4232C,L,R M9E4232C,L,R M9V4232C,L,R**

BMP940025/2001204V  
 (Sheet 1 of 2)



Pellerin Milnor Corporation  
 P. O. Box 400, Kenner, LA 70063-0400

Litho in U.S.A.





**Pellerin Milnor Corporation**  
P. O. Box 400, Kenner, LA 70063-0400

Litho in U.S.A.

Used In	Item	Part Number	Description	Comments
			ASSEMBLIES-----	
A		ARF16001	ASSY=REUSE TANK 4232M7E	
			COMPONENTS-----	
all	1	W3 16239	*WLMT=REUSE TANK 42M7E	
all	2	W3 16241	*WLMT=REUSE TANK LID 42M7E	
all	2	07 50074	DOOR FRONT PANEL HINGE	
all	3	03 16242	REUSE TANK TOP 42M7E	
all	4	W3 16242	*WLMT=REUSE TANK PIPE CVR	
all	5	03 16244A	REUSE PUMP MOTOR BKT 42M7E	
all	6	W3 16243	*WLMT=FLOAT TUBE/LID 42M7E	
all	7	5N1KCLSG42	NPT NIP 1.5XCLS TBE GALSTLSK40	
all	8	60A006B	NEO RUBBER STRIP 1/4"X1"W/PSA	
all	9	5SL1KNFA	NPT ELBOW 90DEG 1.5" GALMAL 15	
all	10	5N1K16AG42	NPT NIP 1.5X16 TBE GALSTL SK40	
all	11	5N1K03AG41	NPT NIP 1.5X3 TOE GALSTL SK40	
all	12	5N1K03AG42	NPT NIP 1.5X3 TBE GALSTL SK40	
all	13	5SR3A2ANF	NPT RED 3X2 GALMAL 150#	
all	13	5SCA2ANF	NPT CAP 2" GALMAL 150#	
all	14	27E955K00B	*MILNOR STRAINER BASKET=MARLO	
all	15	W3 16364	*WLMT=REUSE PERF GUARD	
all	16	27A077	T-BOLT HOSECLAMP 2.438"-2.75"	
all	17	03 16366	REUSE GSKT BACKING PLATE	
all	18	60E255	HOSE 2" WATER CORRUGATED(V50)	
all	19	03 16368	REUSE RUBBER GSKT	
all	20	03 16243C	REUSE TANK PLASTIC PLATE	
all	21	03 16243D	PIPE CVR BACKING PLATE	
all	22	03 16243E	PIPE CVR BACKING SMALL	
all	23	96D220	2" GATE VALVE BRONZE	
all	24	5N2ACLSG42	NPT NIP 2XCLS TBE GALSTL SK40	
all	25	15K041S	HEXCAPSCR 1/4-20UNC2AX1 SS18-8	
all	26	15G170	HEXNIUT 1/4-20UNC2 SS18-8	

Used In	Item	Part Number	Description	Comments
all	27	15U181	LOCKWASHER MEDIUM 1/4 SS18-8	
all	28	15K021A	SOKCAPSCR 10-24UNCX1" LG S/S	
all	29	15K096	HEXCAPSCR 3/8-16UNC2X1SS18-8	
all	30	15G206	HEXNIUT 3/8-16 UNC2 SS 18-8	
all	31	15U260	LOCKWASHER MEDIUM 3/8 SS18-8	
all	32	15U245	FLTWASH 3/8 STD COMM 18-8 SS	
all	33	15U172	FLATWASHER 3/16 (US STD) ZNC	
all	34	15K065	HEXCAPSCR 5/16-18UNC2AX1 GR5 Z	
all	35	15G185	HXNIUT 5/16-18UNC2B SAE ZINC GR	
all	36	15U210	LOKWASHER MEDIUM 5/16 ZINCPL	

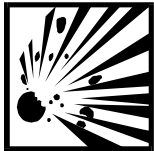
## SERVICING AIR CYLINDERS

This is the general procedure for rebuilding an air cylinder using a Milnor<sup>®</sup> furnished repair kit, once the air cylinder has been removed from the machine. See the specific air cylinder and major assembly parts drawing(s) for component identification and removal/replacement information.

Maintenance procedures require:

- Two threaded rods and nuts, twice the length of the tie bolts.
- The appropriate repair kit.

### ▲ CAUTION ▲



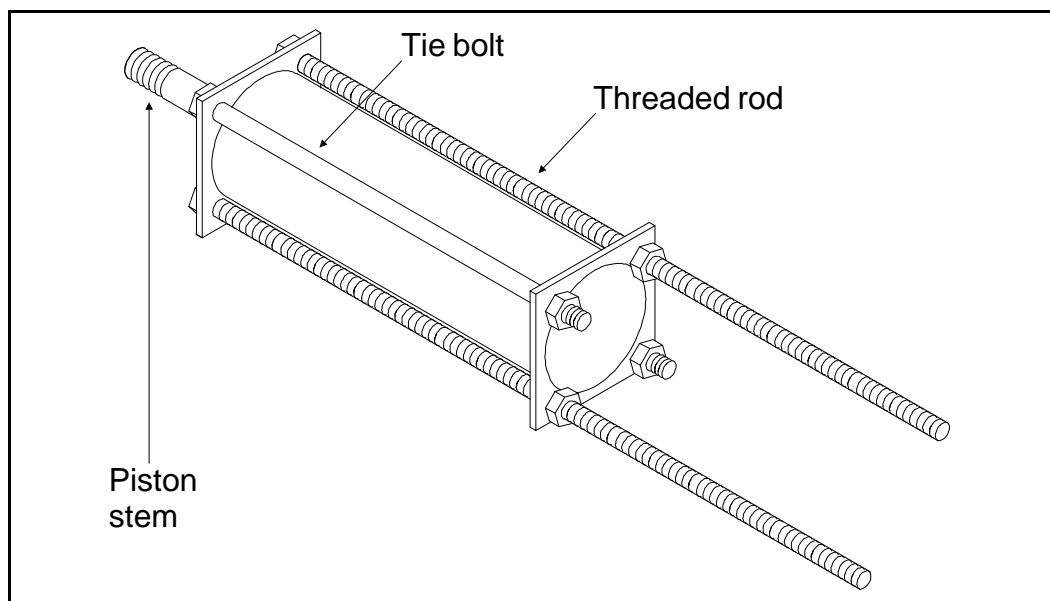
**EXPLOSION HAZARD**—Spring tension can cause air cylinder to burst apart with great force during disassembly. You can be struck by air cylinder parts.

☞ Follow maintenance instructions carefully.

☞ Wear eye protection.

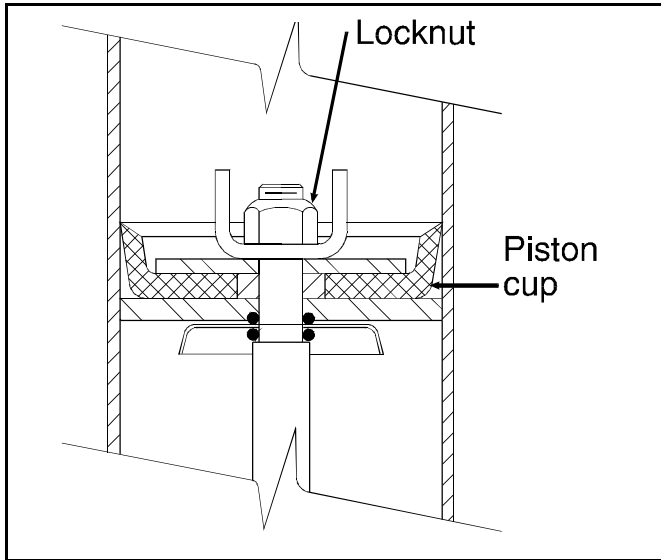
**NOTE:** Use a new locknut when re-assembling air cylinder (see the appropriate parts drawing).

1. Replace two diagonally opposite tie bolts with threaded rods and nuts as shown in FIGURE 1.
2. Tighten nuts on the threaded rods until they contact the air cylinder.
3. Remove the other two tie bolts and the nuts, washers, clips, and actuators from the external end of piston stem.

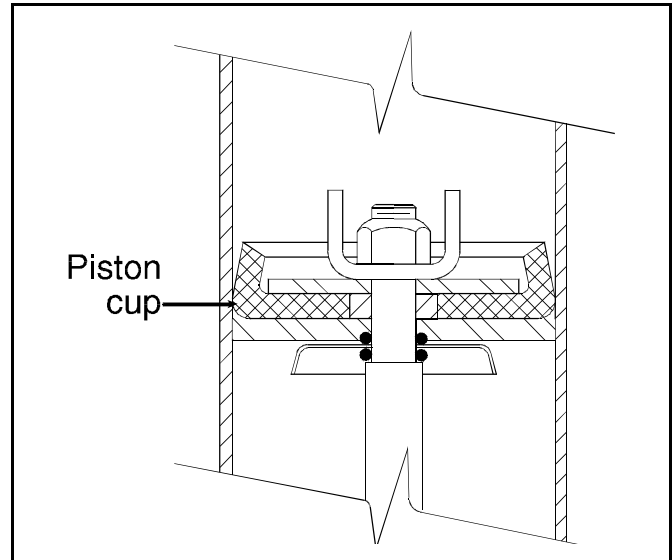


**FIGURE 1** (MSSM0130AE)  
**Using Threaded Rods**

- Loosen nuts on threaded rods evenly, permitting cylinder heads to separate. Use only a few turns on one nut before moving to the other one. Continue until springs have no tension.



**FIGURE 2** (MSSM0130AE)  
**Correct Piston Cup Shape**



**FIGURE 3** (MSSM0130AE)  
**Distorted Piston Cup Shape**

- Note position and orientation of piston cup(s), washers, and springs. Replace worn parts, then reassemble in reverse order. Tighten locknut until it is just barely possible to turn the piston cup and washer assembly on the stem. Correct piston cup shape is shown in FIGURE 2. **DO NOT** overtighten, as this causes the piston cup to deform to the shape shown in FIGURE 3 and may cause piston to bind in cylinder.



# Pneumatic Piping and Assemblies

10

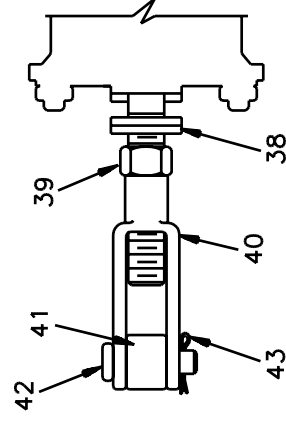
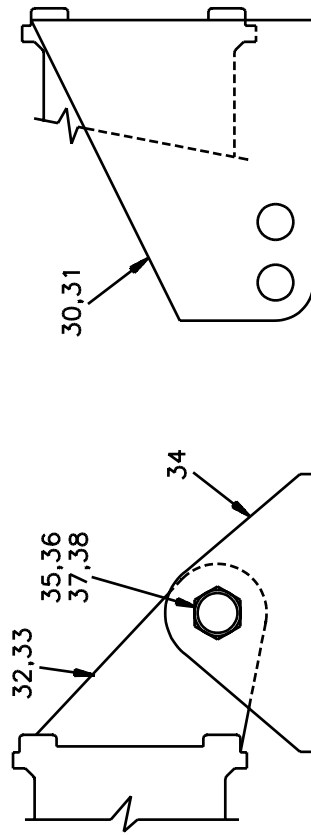
# Air Cylinder Assemblies

BMP830078/2005525B  
(Sheet 1 of 3)

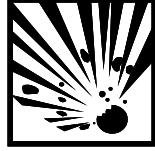


Pellerin Milnor Corporation  
P. O. Box 400, Kenner, LA 70063-0400

Litho in U.S.A.

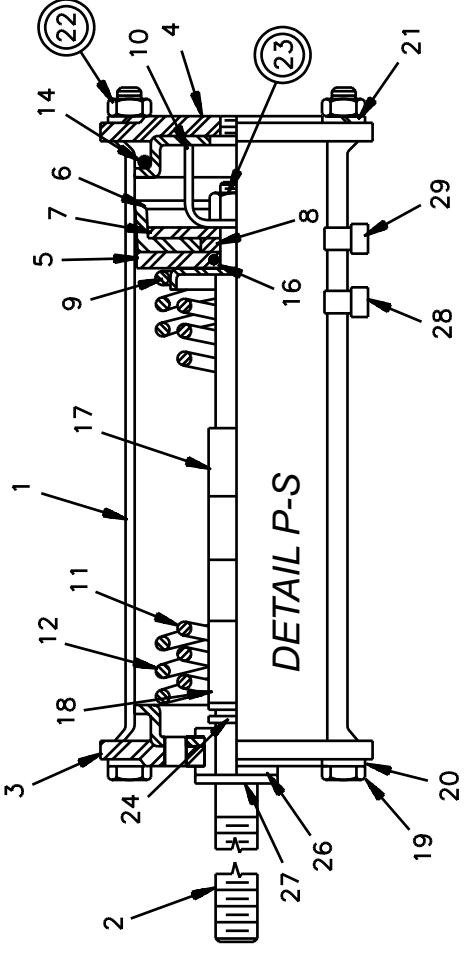
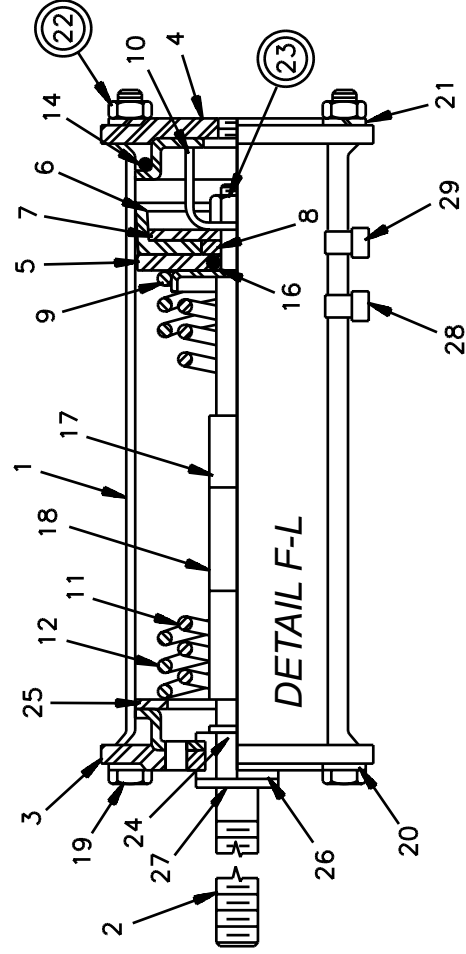
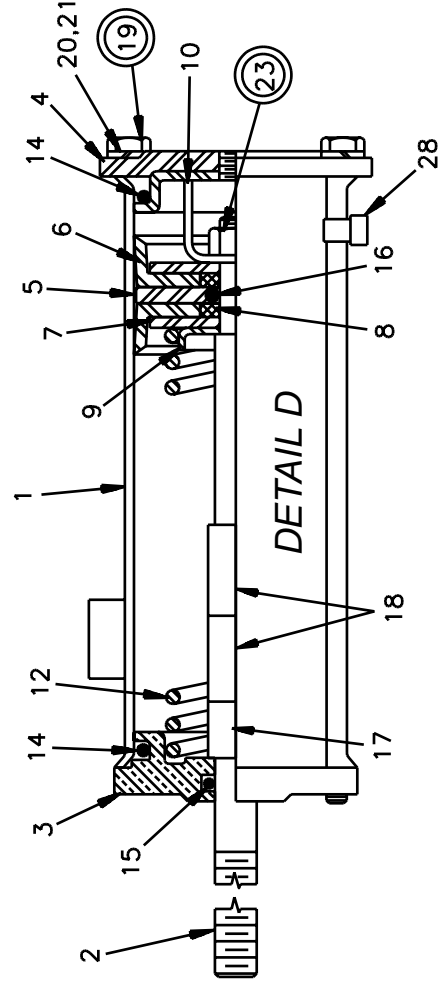
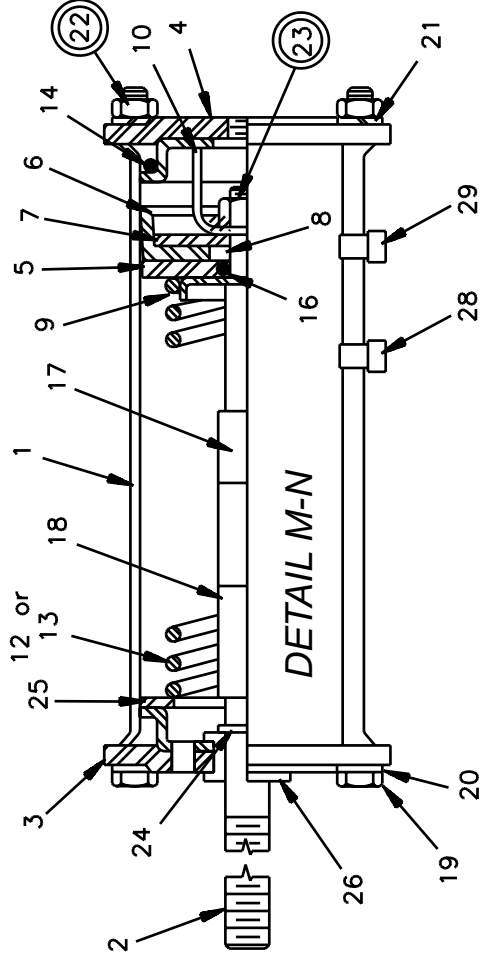
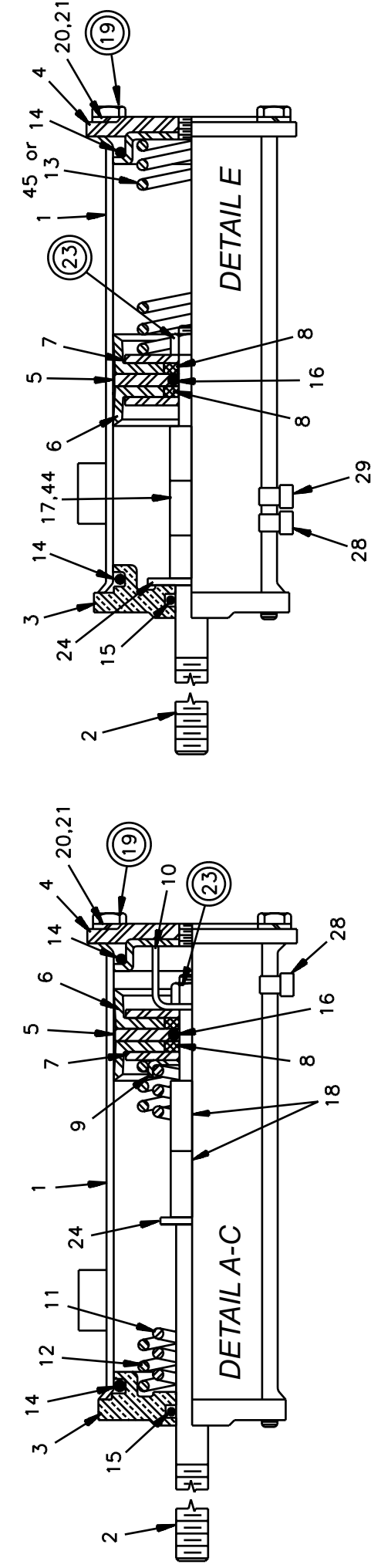


## **A WARNING**



**EXPLOSION HAZARD** - Air cylinder can burst apart with great force.  
Circled items are under high spring tension.  
Follow maintenance instructions MSSM0130AE carefully.

### AIR CYLINDER MOUNTING HARDWARE







Pellerin Milnor Corporation  
P. O. Box 400, Kenner, LA 70063-0400

Litho in U.S.A.

Parts List—Air Cylinder Assemblies				Parts List, cont.—Air Cylinder Assemblies			
Used In	Item	Part Number	Description	Used In	Item	Part Number	Description
<p>Find the correct assembly first, then find the needed components. The item letters (A, B, C, etc.) assigned to assemblies are referred to in the "Used In" column to identify which components belong to an assembly. The item numbers (1, 2, 3, etc.) assigned to components relate the parts list to the illustration.</p>							
ASSEMBLIES							
A		SA 36 035	89483V* AIRCYL=BRAKE ASSY	ALL	8	02 02185	79237A WASHER=PISTON CUP COMP LIMIT
B		SA 28 128	89483T* BRAKE AIRCYL 2-WAY 60+72SGU	A-D,F-Q,S	9	02 18651	73171A WASHER=2WAY BRAKECYL
C		SA 28 152	89483V* BRAKE AIRCYL 2-WAY 60WE2+3	A-D,F-Q,S	10	03 01313	70219A STOP=AIR CYL W/2+11/16STROKE
D		SA 10 019A	89483U* BRAKE AIRCYL,2-WAY=42WE+DAU	A-C,F-L,P-Q	11	02 15880	96471B SPRING=BRAKE1.5OD10.3FL17#/"
F		A52 00200	89463U* BRAKE AIRCYL=7244 TILT ONLY	S			
G		SA 10 019Q	89483T*BRAKE CYL ASSY=4226QWE+DYA	A,D,F-M,Q,S	12	02 15881	96471# SPRING=BRAKE2.1OD11FL15.5#/"
H		AAC14001A	90000Z AIRCYL-LONG= 4256PFG	N	13	02 17023	83392B SPRING-SS=DUMP 1.5OD8FL21#/"
I		A76AC001A	89463T AIR CYL.2-3/8 BORE 2"STROKE	ALL	14	60C132	ORING 2"IDX3/16CS BUNA70 #329
J		A76AC001B	89463@ AIR CYL.2-3/8 BORE 3"STROKE	A-D	15	60C110	ORING 1/2IDX3/32CS BUNA70 #112
K		A75 01200	89463T*AIR CYL. DAMPER = 3"STROKE	ALL	16	60C106	ORING 5/16ID 1/16CS BUNA70#011
L		A75 01300	89463U*AIR CYL. DAMPER = 2"STROKE	D,G-J,L-N	17	27B240	SPCRROLL.5ID.813L.062T STLZNC
M		SA 10 019	89497U* BRAKE AIRCYL=BALCOM+DIVCYL	Q,S			
N		AAC14001	90041U*AIRCYL=RATE 50-91 STRK 2.09	A,C-D,F-Q,L	18	27B250	SPCRROLL.5ID1.5L.062T STLZNC
P		A25 00600	89457V* BRAKE AIRCYL=52WE1 +52TILT	S	19	02 10585E	91142# TIE BOLT=5/16-18X8.25LG PLTD
Q		AAC64001	894613*AIRCYL=BRAKE ASSY 6442	ALL	19	02 10585E	91142# TIE BOLT=5/16-18X8.25LG PLTD
R		AAC65001	93481B AIRCYL=BRAKE ASSY 6446E6N	R ONLY	19	W6 20702F	90293B*FLOW NOT VLV=AIR-CYL ROD WLD
S		AAC58001	95000Z AIRCYL=BRAKE ASSY 7258J2N	ALL	20	15U200	FLATWASHER(USS STD) 5/16"ZNC PLT
COMPONENTS							
A-D	1	W2 18646	93344L CYLINDER-AIR=DOUBLEACT BRAKE	A,C,F-G,I-J	24	15U243	FLAWASHER 7/8ODX33/64IDX16GA ZINCPL
F-S	1	02 02068	94266A AIRCYL-STAINLESS=DUMPVALVE	L,Q,S			
A-D,F-G,S, I-K,M-Q	2	02 18650	96431B STEM=2 WAY AIRCYLINDER BRAKE	F-N	25	15U520	FLAT WASHER 2+3/8X1+41/64X12GA ZINC
H	2	03 06313A	96431# STEM=AIR CYL 304SS	F-Q,S	26	54E220	NYLNR 8L2FF BUSH 1/2X9/16X.140
L	2	02 18650A	96417B STEM-AIRCYL UPLOCK PRESS	F,K,I-J,Q,S	27	17B012	EXTRETRING IND#1000-50-ST-ZD ZINC
R	2	02 18650B	97362B STEM=2WAY AIRCYL BRAKE 7.88L	A	28	20L601R	ID TAG NAT'L #1614 ALUM EMB LET "R"
A-D	3	02 18660	CYLHEAD-BRASS=2WAY AIRCYL	B	28	20L601U	ID TAG NAT'L #1614 ALUM EMB LET "U"
F-Q	3	02 02546	CYLHEAD=SLIDESTEM	C	28	20L601P	ID TAG NAT'L #1614 ALUM EMB LET "P"
R	3	06 20702E	91227B FLOW NOT ACTUATOR CYL HEAD	D	28	20L601X	ID TAG NAT'L #1614 ALUM EMB LET "X"
S	4	02 02101	71334A CYLHEAD W/TAPPED HOLE	S	28	20L601J	ID TAG NAT'L #1614 ALUM EMB LET "J"
ALL	5	02 02105	91522A PISTON CUP WASHER STNLS STL	F,H,Q,S	28	20L601A	ID TAG NAT'L #1614 ALUM EMB LET "A"
S	5	02 02105B	92253B 2.38"ACYL BRASS PISCUP WASHR	G	28	20L601Q	ID TAG NAT'L #1614 ALUM EMB LET "Q"
ALL	6	02 02194	93217B PISTONCUP=DUMPVALVE 2+3/8"	M	28	20L601F	ID TAG NAT'L #1614 ALUM EMB LET "F"
ALL	7	02 02085	75161A UP WASHER=2"OD=PISTONCUP	N	28	20L601D	ID TAG NAT'L #1614 ALUM EMB LET "D"
				P	28	20L601V	ID TAG NAT'L #1614 ALUM EMB LET "V"
				K	28	20L601V	ID TAG NAT'L #1614 ALUM EMB LET "V"
				I-J,L	28	20L601E	ID TAG NAT'L #1614 ALUM EMB LET "E"
				F,I-L	29	20L601A	ID TAG NAT'L #1614 ALUM EMB LET "A"
				G-H	29	20L601F	ID TAG NAT'L #1614 ALUM EMB LET "F"



Pellerin Milnor Corporation  
P. O. Box 400, Kenner, LA 70063-0400

Litho in U.S.A.

**Parts List, cont.—Air Cylinder Assemblies**

Used In	Item	Part Number	Description	Comments
N	29	20L601C	ID TAG NAT'L #1614 ALUM EMB LET "C"	
Q	29	20L601D	ID TAG NAT'L #1614 ALUM EMB LET "D"	
ALL	30	03 06309	70310C RIGHTMOUNT=BRAKE CYL ZNC	RIGHT
ALL	31	03 06308	70310C LEFTMOUNT=BRAKE CYL ZINC	LEFT
ALL	32	02 02550	97437ABRKT=AIRCYL-RIGHT ZINC/CAD	RIGHT
ALL	33	02 02547	LT BRACKET=AIRCYL CAD	LEFT
ALL	34	02 02556	SUPPORT=AIRCYL CADSTL	
ALL	35	27B2750LOT	01Z SPC RROLL.562ID.937L.048T ZNK	
ALL	36	15K206	HEXCAPSCR M5-.8X40MM 18-8SS	
ALL	37	15G235F	HXFNJAMNUT 9/16-12UNC2B ZINC GR2	
ALL	38	15U280	01Z FL+WASHER(USS STD)1/2 ZNC PL+D	
ALL	39	15G230	HXNUT 1/2-13UNC2B SAE ZINC GR2	
ALL	40	17A020	ADJ CLEVIS MACHINED 1/2-13 ZINC PLT	
ALL	41	17A065	01Z EYEEND 1/2-13 X2.25 ZINC	
ALL	42	17A040	CLEVISPIN 1/2"X1+3/8" DRILLED	
ALL	43	15H030	STDCOTTERPIN 3/32X3/4 ZINCPL	
ALL	44	27B34010SZ	SPCRROLL.512ID.625L.062T STLZC	
ALL	45	02 17024	94302B SPRING-SS=DUMP 1.5OD4FL40#"	