



Published Manual Number: MTCEPB01

- Specified Date: 20130909
- As-of Date: 20130909
- Access Date: 20130909
- Depth: Detail
- Custom: n/a
- Applicability: CEP
- Language Code: ENG01, Purpose: publication, Format: 1colA

General—

Operating and Troubleshooting Washer-extractors with the E-P OneTouch® Controller

Applicable Milnor® products by model number:

MWR09E5- MWR12E5- MWR16E5- MWR18E4-

Preface

BICEUK01 (Published) Book specs- Dates: 20130909 / 20130909 / 20130909 Lang: ENG01 Applic: CEP

i. About This Manual

i. 1. Scope

This manual provides commissioning, operating, and troubleshooting instructions for washer-extractors in the Milnor® MWR_ line. These machines are equipped with the Milnor® E-P OneTouch® control. See the installation manual for information on machine installation procedures and mechanical requirements. See the service manual for preventive maintenance, service procedures, and mechanical parts identification. See the schematic manual for electrical parts identification and electrical troubleshooting instructions.

Notice 1: Milnor MWR_ models sold in North and South America employ the controller board with Milnor part number 08BT168AT. Similar models sold in Asia may employ controller board 08BT168AT or the controller board with Milnor part number 08BT168BT. Some minor differences are determined by the market for which any particular machine is manufactured, but operation and most troubleshooting procedures are the same. When necessary for clarity in this manual, specific differences will be identified by the controller board part number.

i. 2. If this Manual Does Not Have the Necessary Data [Document BIUUUD17]

This manual has the best data that was available when your machine was made. If you cannot find the necessary data:

- **Are you looking for data about a component not made by Milnor® but used on your machine—for example, a motor or a brake caliper?** We usually do not put the instructions of component manufacturers in Milnor manuals. You can find some of these instructions in the part of the Milnor website that gives maintenance data (<http://www.milnor.com/tkbsearch18.asp>). You can also find instructions for many components on the manufacturers' websites.
- **Are you looking for data about a Milnor component on your machine that this manual does not give?** If we get better data or more data after the manual is available, we will add it to a newer version of the manual. Speak with the Milnor Customer Support group. They can give you newer instructions if they are available or help you if not.

i. 3. How to Identify this Manual and its Included Documents [Document BIUUUD13]



This document uses Simplified Technical English.
Learn more at <http://www.asd-ste100.org>.

Use the specifications on the front cover of this manual to identify this manual or the included documents. This section tells about these specifications.

Published manual number—The primary identification number for the manual.

Specified date—The first assembly date for the machine or change about which this manual gives data.

As-of date—The company makes new manuals about items that are not new. These new manuals will include data started before this date.

Access date—The date Milnor prepared the manual for its publication.

Depth—“Detail” manuals show the maximum available data. “Synopsis” manuals show the minimum necessary data. A manual with more data goes with a synopsis manual.

Custom—A value of “n/a” here shows that this manual applies to all machines identified on the inner front cover of the manual. Other values show the laundry name and a code for the specified machine.

Applicability—Each value here shows the machines or model numbers that this manual applies to. The inner front cover shows the full list of the applicable models. If this value is “not used,” this manual has a different function.

Language Code—The value here shows the language and dialect of this manual. “Eng01” shows that the manual uses United States English.

Refer to a **document** in this manual with all of the specifications shown on the front cover. Replace the published manual number with the document number.

i. 4. Trademarks [Document BIUUUD14]

i. 4.1. **Trademarks of Pellerin Milnor Corporation**—These words are trademarks of Pellerin Milnor Corporation:

Table 1: Trademarks

| | | | | |
|--------------|--------------|----------|------------|--------------|
| CBW® | E-P Plus® | Mentor® | MilTouch™ | RinSave® |
| E-P Express® | ExactXtract® | Mildata® | PulseFlow® | Staph Guard® |
| | GreenTurn™ | Milnor® | RecircONE™ | |

i. 4.2. **Trademarks of Other Companies**—These words are trademarks of other companies:

Table 2: Trademarks

| | | | | |
|-------------|-------------------------|-----------------------|-----------------------|--------------------------|
| Acronis® | IBM® | Microsoft Office XP® | Microsoft Access® | Siemens® |
| Atlas 2000® | Microsoft Windows 2000® | Microsoft Windows NT® | Microsoft Windows XP® | Seagate Crystal Reports® |
| | | Yaskawa® | | |

— End of BICEUK01 —

ii. Contacting Milnor®

Your authorized Milnor dealer can assist you with any aspect of your Milnor machine and is familiar with local conditions that may be pertinent to its installation, use, or maintenance. Always contact your dealer first. Should you or your dealer need assistance from the Milnor factory, refer to [Table 3](#) for contact information.

Table 3: Pellerin Milnor Corporation Contact Information

| Purpose | Department | Telephone | FAX | E-mail/Website |
|--|--|------------------|--------------|--|
| Order, or enquire about replacement parts | Parts | 504-467-2787 | 504-469-9777 | parts@milnor.com |
| Obtain advice on installing, servicing, or using | Customer Service/ Technical Support | 504-464-0163 | 504-469-9777 | service@milnor.com www.milnor.com (Customer Service) |
| Learn about, request, or enroll in Milnor service seminars | Training | 504-712-7725 | 504-469-9777 | training@milnor.com |
| Determine warranty eligibility or claim status | Warranty Administration | 504-712-7735 | 504-469-9777 | service@milnor.com (Attention: Warranty) |
| Ask about, comment on, or report an error in equipment manuals | Technical Publications | 504-712-7636 | 504-469-1849 | techpub@milnor.com |

Your first contact with any question should be your authorized Milnor dealer, but problems or special situations encountered in the field may require consultation with the Milnor factory. Written correspondence can be mailed to this address:

Pellerin Milnor Corporation
 Post Office Box 400
 Kenner, Louisiana 70063-0400
 Telephone: 504-467-9591
<http://www.milnor.com>

— End of BIUUUK06 —

Table of Contents

| Sections | Figures, Tables, and Supplements |
|--|--|
| Preface | |
| i. About This Manual (Document BICEUK01) | |
| i.1. Scope | |
| i.2. If this Manual Does Not Have the Necessary Data (Document BIUUUD17) | |
| i.3. How to Identify this Manual and its Included Documents (Document BIUUUD13) | |
| i.4. Trademarks (Document BIUUUD14) | |
| i.4.1. Trademarks of Pellerin Milnor Corporation | Table 1: Trademarks |
| i.4.2. Trademarks of Other Companies | Table 2: Trademarks |
| ii. Contacting Milnor® (Document BIUUUK06) | Table 3: Pellerin Milnor Corporation Contact Information |
| Table of Contents | |
| Chapter 1. Commissioning | |
| 1.1. Important Owner/User Information (Document BICEUK02) | |
| 1.1.1. Ensure Safety of All Laundry Personnel | |
| 1.1.2. Customize the Machine Controller | |
| 1.2. About the Forces Transmitted by Washer-extractors (Document BIWUUI02) | |
| 1.2.1. Foundation Considerations | |
| 1.2.2. How Strong and Rigid? | Figure 1: How Rotating Forces Act on the Foundation |
| 1.3. Important Instructions for Pumped Chemical Inlets (Document BIWUUI01) | |
| 1.3.1. How Pumped Chemical Systems can Internally Damage the Washer-extractor | Supplement 1: Preventing Dribbling by Purging Chemical Lines |
| 1.3.2. Locating Chemical System Components to Reduce the Risk of Internal Damage | Figure 2: Proper Routing of Chemical Tubing |
| 1.3.3. Preventing Leaks Which Can Injure Personnel and Cause External Damage | Figure 3: Rear-mounted Water and Liquid Supply Injector |
| 1.4. Electrical Connections for Liquid Chemical Systems (Document BICEUI01) | Supplement 2: Maximizing Chemical Injection Precision |
| 1.4.1. Pump Signal Connections | Table 4: Chemical Injection Signals |
| | Figure 4: Pump Signal Connections |
| 1.4.2. <i>Timer Stop</i> Connections | Figure 5: <i>Timer Stop</i> Connections |

Sections

Figures, Tables, and Supplements

Chapter 2. Configuring**2.1. Configuring E-P OneTouch® Washer-extractor Models**

(Document BICEUC01)

- 2.1.1. Is this switch position ON or OFF?
- 2.1.2. Configuration Decisions for Machines with Controller 08BT168AT or 98CMCR0911
 - 2.1.2.1. Position 1: Use Formula Set #1?
 - 2.1.2.2. Position 2: Cold final rinse?
 - 2.1.2.3. Positions 3 through 6: Formula Set Selection
 - 2.1.2.3.1. Standard Formulas for Hotel and Hospitality
 - 2.1.2.3.2. GreenTurn Formulas for Hotel and Hospitality
 - 2.1.2.3.3. Standard Formulas for Healthcare
 - 2.1.2.3.4. GreenTurn Formulas for Healthcare
 - 2.1.2.4. Position 7: Normal operation?
 - 2.1.2.5. Position 8: Run formulas?

Figure 6: Typical DIP switch on 08BT168AT

2.2. Available E-P OneTouch® Wash Formulas (softwares WUT5E1A and WUMWR1D) (Document BICEUP05)

- 2.2.1. Hotel and Hospitality Configuration (Document BICEUP07)
 - 2.2.1.1. Standard Formulas for Hotel and Hospitality
 - 2.2.1.2. GreenTurn™ Formulas for Hotel and Hospitality
- 2.2.2. Healthcare Configuration (Document BICEUP08)
 - 2.2.2.1. Standard Formulas for Healthcare
 - 2.2.2.2. GreenTurn™ Formulas for Healthcare

Table 5: Standard Formula Set #1
 Table 6: Standard Formula Set #2
 Table 7: GreenTurn™ Formula Set #1
 Table 8: GreenTurn™ Formula Set #2

Table 9: Standard Formula Set #1
 Table 10: Standard Formula Set #2
 Table 11: GreenTurn™ Formula Set #1
 Table 12: GreenTurn™ Formula Set #2

Chapter 3. Operating**3.1. Determining Load Size (Document BIWUU001)****3.2. Controls on E-P OneTouch® Model Washer-extractors (Document BICEUF01)**

- 3.2.1. Control Functions During Normal Operation
 - 3.2.1.1. *Formula Selection* Buttons
 - 3.2.1.2. *Terminate* Button
 - 3.2.1.3. *Last Rinse* Light
 - 3.2.1.4. *In Progress* Light
 - 3.2.1.5. *Door Unlock* Button
- 3.2.2. Control Functions During Testing

Figure 7: E-P OneTouch® Controls

| Sections | Figures, Tables, and Supplements |
|--|--|
| 3.2.2.1. <i>Formula Selection</i> Buttons | |
| 3.2.2.1.1. <i>Formula A</i> button (A) | |
| 3.2.2.1.2. <i>Formula B</i> button (B) | |
| 3.2.2.1.3. <i>Formula C</i> button (C) | |
| 3.2.2.1.4. <i>Formula D</i> button (D) | |
| 3.2.2.2. <i>Terminate</i> Button | |
| 3.2.2.3. <i>Last Rinse</i> Light | |
| 3.2.2.4. <i>In Progress</i> Light | |
| 3.2.2.5. <i>Door Unlock</i> Button | |
| 3.3. E-P OneTouch® Operation (Document BICEU001) | |
| 3.3.1. Instructions for Normal Operation | |
| 3.3.1.1. Load the Machine | |
| 3.3.1.2. Start a Formula | |
| 3.3.1.2.1. After a Completed Formula (Normal) | |
| 3.3.1.2.2. After Opening the Door during a Formula | |
| 3.3.1.3. Unload the Machine | |
| 3.3.2. How to End a Formula Early | |
| Chapter 4. Testing and Troubleshooting | |
| 4.1. Troubleshooting Errors (Document BICEUT03) | |
| 4.1.1. Vibration Switch Tripped | |
| 4.1.2. Door Open | |
| 4.1.3. High Level Still Made | |
| 4.1.4. Door/Inverter Fault | |
| 4.1.4.1. Fault Occurs before a Formula Starts | |
| 4.1.4.2. Fault Occurs During Operation | |
| 4.2. Testing MWR_ Washer-extractors (Document BICEPT02) | |
| 4.2.1. Testing without the Display Kit | Chart 1: Operating Sequence Part 1 Chart 2: Operating Sequence Part 2 Chart 3: Operating Sequence Part 3 Chart 4: Operating Sequence Part 4 |
| 4.2.2. Testing with the Display Kit | Figure 8: Processor Boards |
| 4.2.2.1. Connecting the Display | Chart 5: Overview of Run Mode Diagnostics |
| 4.2.2.2. Displays in Run Mode | |
| 4.2.2.2.1. Timer Display | |
| 4.2.2.2.2. DIP Switch Display | |
| 4.2.2.2.3. Inputs Display | Table 13: E-P OneTouch Inputs |
| 4.2.2.2.4. Outputs Display | Table 14: E-P OneTouch Outputs |
| 4.2.2.2.5. Analog-to-Digital Channels Display | |
| 4.2.2.3. Displays in Test Mode | |

| Sections | Figures, Tables, and Supplements |
|---|---|
| 4.2.2.3.1. Setting the DIP Switch for Test Mode | Figure 9: Test Mode Selected |
| 4.2.2.3.2. Interpreting the Display | |
| 4.2.2.3.3. DIP Switch Display | |
| 4.2.2.3.4. Viewing Inputs | |
| 4.2.2.3.5. Testing Outputs | Figure 10: Level Switch Testing |

Chapter 1

Commissioning

BICEUK02 (Published) Book specs- Dates: 20130909 / 20130909 / 20130909 Lang: ENG01 Applic: CEP

1.1. Important Owner/User Information

The following two procedures must be completed before this machine is placed in service:

1. Ensure the safety of all laundry personnel.
2. Customize the machine controller for the intended machine application.

1.1.1. Ensure Safety of All Laundry Personnel

Ensure that all personnel who will operate or maintain this machine read the safety manual before permitting them to access the machine. Ensure that all user manuals are available to the appropriate personnel and that all precautions explained in all applicable manuals are observed.

1.1.2. Customize the Machine Controller

Customizing the controller includes verifying that it is configured for the particular application (set of four pre-programmed formulas) for which the machine will be used. Always verify the machine configuration when the machine is first placed in service and after replacing the microprocessor controller.

Configure this machine by setting DIP switch SW1 on the microprocessor controller. See [Section 2.1. “Configuring E-P OneTouch® Washer-extractor Models”](#) in this manual for the location of detailed configuration instructions.

— End of BICEUK02 —

BIWUUI02 (Published) Book specs- Dates: 20130909 / 20130909 / 20130909 Lang: ENG01 Applic: CEP

1.2. About the Forces Transmitted by Washer-extractors

During washing and extracting, all washer-extractors transmit both static and dynamic (cyclic) forces to the floor, foundation, or any other supporting structure. During washing, the impact of the goods as they drop imparts forces which are quite difficult to quantify. Size for size, both rigid and flexibly-mounted machines transmit approximately the same forces during washing. During extracting, rigid machines transmit forces up to 30 times greater than equivalent flexibly-mounted models. The actual magnitude of these forces vary according to several factors:

- machine size,
- final extraction speed,
- amount, condition, and type of goods being processed,
- the liquor level and chemical conditions in the bath preceding extraction, and
- other miscellaneous factors.

Estimates of the maximum force normally encountered are available for each model and size upon request. Floor or foundation sizes shown on any Milnor® document are only for on-grade situations based only on previous experience without implying any warranty, obligation, or responsibility on our part.

1.2.1. Foundation Considerations

1.2.2. How Strong and Rigid?

Many building codes in the U.S.A. specify that laundry floors must have a minimum live load capacity of 150 pounds per square foot (732 kilograms per square meter). However, even compliance with this or any other standard does not necessarily guarantee sufficient rigidity. In any event, it is the sole responsibility of the owner/user to assure that the floor and/or any other supporting structure exceeds not only all applicable building codes, but also that the floor and/or any other supporting structure for each washer-extractor or group of washer-extractors actually has sufficient strength and rigidity, plus a reasonable factor of safety for both, to support the weight of all the fully loaded machine(s) including the weight of the water and goods, and including the published 360-degree rotating sinusoidal RMS forces that are transmitted by the machine(s). Moreover, the floor, foundation, or other supporting structure must have sufficient rigidity (i.e., a natural or resonant frequency many times greater than the machine speed with a reasonable factor of safety); otherwise, the mentioned 360-degree rotating sinusoidal RMS forces can be multiplied and magnified many times. It is especially important to consider all potential vibration problems that might occur due to all possible combinations of forcing frequencies (rotating speeds) of the machine(s) compared to the natural frequencies of the floor and/or any other supporting structure(s). A qualified soil and/or structural engineer must be engaged for this purpose.

Figure 1: How Rotating Forces Act on the Foundation

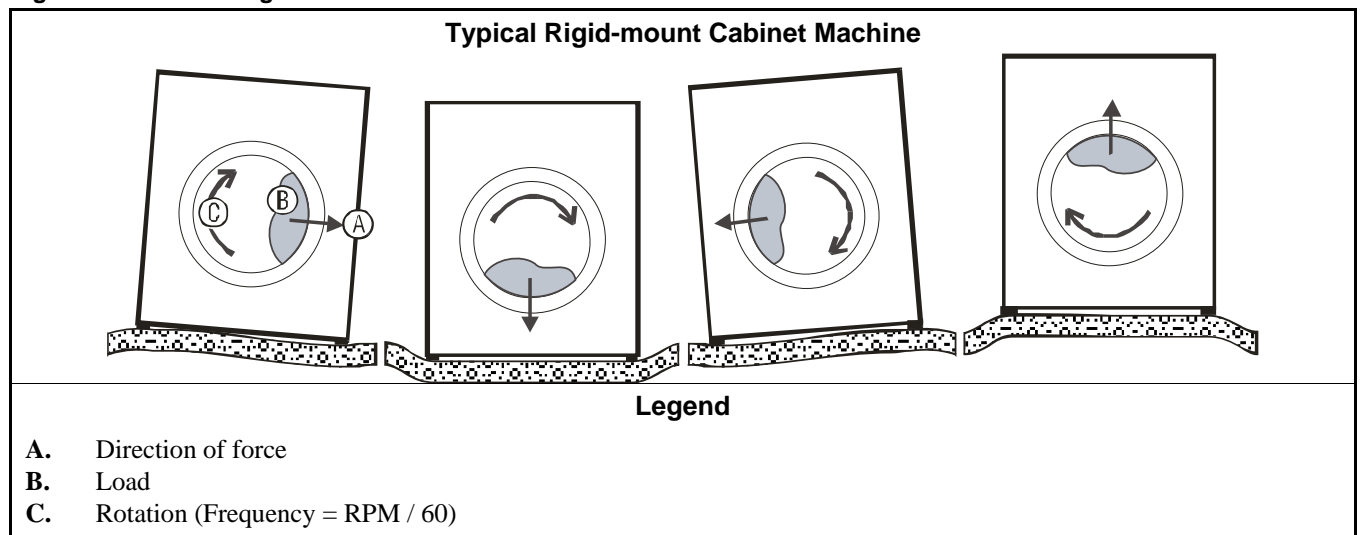

The figure(s) above depict(s) both on-grade and above-grade installations as well as models installed directly on a floor slab or on a foundation poured integrally with the slab. Current machine data is available from Milnor® upon request. All data is subject to change without notice and may have changed since last printed. It is the sole responsibility of every potential owner to obtain written confirmation that any data furnished by Milnor® applies for the model(s) and serial number(s) of the specific machines.

— End of BIWUUI02 —

1.3. Important Instructions for Pumped Chemical Inlets

1.3.1. How Pumped Chemical Systems can Internally Damage the Washer-extractor

Many pumped liquid chemical systems dribble concentrated chemicals out of the injection tubes when the system is not used for relatively long periods of time—as after working hours and during weekends. This puts highly concentrated corrosive chemicals in direct contact with dry stainless steel surfaces, and often directly on any textiles left in the machine. **Chemical deterioration (rusting) of the stainless steel and damage to the textiles is the inevitable result.**

Pellerin Milnor Corporation accepts absolutely no responsibility whatsoever for damage to its equipment or to any textiles therein when concentrated chemicals dribble out of the injection tubes onto any part of the machine or its contents.

Supplement 1

Preventing Dribbling by Purging Chemical Lines

Although the injection site is flushed by washer agitation on some models and after each injection on other models to aid the injection process, this flushing provides absolutely no protection against harmful dribble which occurs later—when the machine is no longer in use.

One foolproof solution for “dribbling” is to completely purge the appropriate chemical injection tube with fresh water after every injection, so that only fresh water (which cannot cause a problem) can dribble out.

Obviously, it is the sole responsibility of the pump and/or chemical supplier (not the machine manufacturer) to furnish such a flushing device. (We understand that such flushing type chemical injection systems—both for retrofit to existing systems and for new installations—are now offered by others.)

1.3.2. Locating Chemical System Components to Reduce the Risk of Internal Damage

If the tubes, pumps, and chemical tanks are kept well below the injection point, the likelihood of “after-hours dribbling” is reduced, but not totally eliminated.

We therefore urge that tubes from any non-flushing pumped chemical system be connected as shown in [Figure 2](#). Although fresh-water flushing the just-used tubes after each injection would be better, we believe routing the tubes as indicated will probably minimize the dribbling effect about as much as possible without flushing. Never permit tanks, pumps, or any portion of the tubes to be higher than the injection point. If loops in the injection tubes are employed, make sure the entire loop is well below the injection point.

Figure 2: Proper Routing of Chemical Tubing

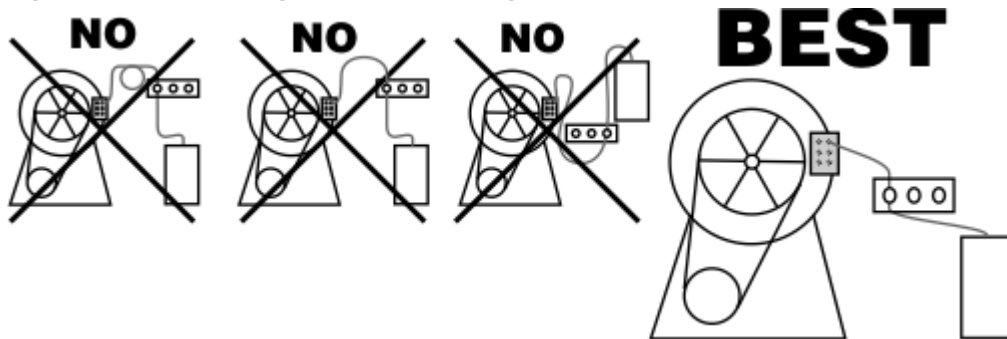

Note 1: As shown in Figure 2, all tanks, pumps, and tubing must be lower than the injection point on the machine and must not dribble chemicals into the machine, nor leak chemicals externally onto any portion of the machine or its surroundings.

1.3.3. Preventing Leaks Which Can Injure Personnel and Cause External Damage

Any ports on the inlet are plugged at the Milnor® factory. When replacing plugs with fittings or when reinstalling plugs, always use the sealant furnished (LocTite® RTV Silicone Adhesive or equivalent). Use properly sized hose barbs, always use clamps, and check for leaks. Use the hose barbs furnished with your machine only if they provide the proper fit for the tubes employed. Ensure that excessive pressures cannot build up that might burst or disconnect tubing. Instruct the operator to monitor for leaks and report any occurrences.

When calibrating injections, it is permissible to remove tubes from barbed fittings to take samples. However, always check for leaks after installing tubes and clamps. A preferable method for sampling is to install a three-way valve, or two two-way valves and a tee fitting, onto each injection tube.



WARNING 3: Avoid chemical burns and corrosion—Concentrated liquid chemicals leaking from a chemical system can burn skin and eyes, cause other types of injury or illness, and corrode machine components.

- Ensure that excessive pressures cannot build up which might burst or disconnect a chemical delivery tube.
- Ensure that there are no external chemical leaks when the system is installed or calibrated.
- Periodically check the system for leaks during operation.



CAUTION 4: Avoid corrosion and textile damage—Chemicals dribbling into the machine when it is idle will corrode machine components and damage any textiles left in the machine.

- If possible, use a system that flushes the entire chemical delivery tube after each injection.
- If a non-flushing system is used, install tanks, pumps, and tubing below the injection point on the machine, such that chemicals travel to the machine at an upward angle.



CAUTION 5: Avoid explosions—Certain chemicals will react chemically when combined. Consult with your chemical supplier representative about the safe use of chemicals.

- Connect chemical tubing so that bleach and sour inlets are as far apart as possible.

Figure 3: Rear-mounted Water and Liquid Supply Injector

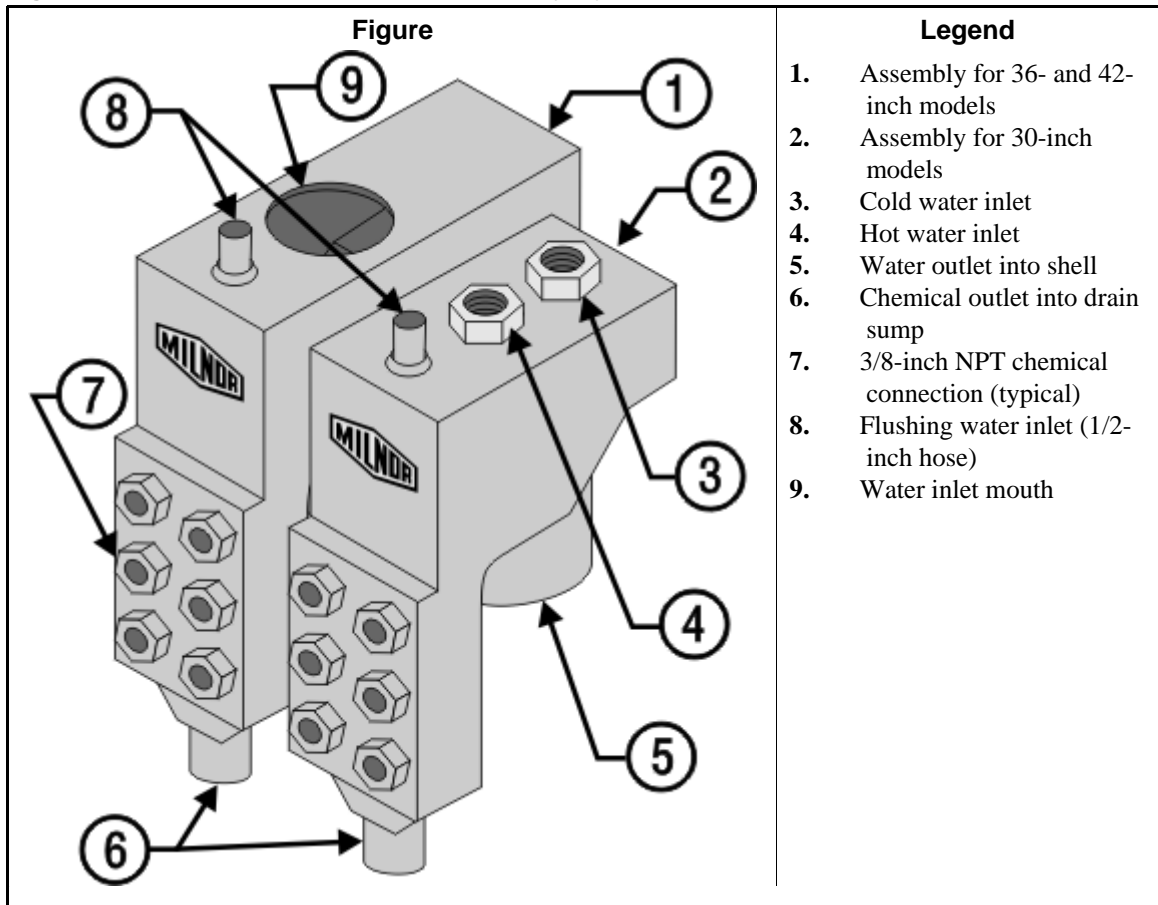

Notice [6]: Pellerin Milnor Corporation accepts absolutely no responsibility for damage to its equipment or to any textiles therein when concentrated chemicals dribble out of the injection tubes onto any part of the machine or its contents.

— End of BIWUI01 —

1.4. Electrical Connections for Liquid Chemical Systems



WARNING [7]: Electric Shock Hazard—Contact with high voltage electricity will kill or seriously injure you. Even when the machine is not running, three-phase power and control circuit power are still present at several locations within the cabinet and at some electrical components.



CAUTION [8]: Injury and Damage Hazards—Improper wiring can cause the machine to malfunction, risking injury to personnel, damage to machine components, and damage to goods.

- Electrical and piping connections described in this section must be made only by qualified, authorized personnel.
- Lock off and tag out power at the external disconnect switches for the washer-extractor before proceeding.
- Do not rely merely on the information in this section when wiring. Consult all applicable electrical schematics.

- Do not reroute or rearrange any wires not specifically permitted by this instruction.
- Do not connect a common wire to ground. Use the common terminal furnished.



CAUTION 9: Risk of Poor or Inconsistent Wash Quality—Injection times of less than 10 seconds are discouraged because fine adjustments are not possible, and factors such as pump lag time may cause significant variations in the amount of chemical delivered.

- Size pumps or valves small enough for adequate control (i.e., for longer injection times).
- Use two pumps or valves to inject a small or large quantity of the same chemical, if required.

Supplement 2

Maximizing Chemical Injection Precision

Injection of a consistent amount of chemical is important in controlling wash quality and using chemicals economically. When chemicals are injected by units of time, as is done with most washer-extractors, injections of short duration can be imprecise because of two reasons:

- Fine adjustments to the delivered quantity are not possible. For example, if an injection of three seconds is extended by one second, the quantity delivered is theoretically increased by more than 30 percent. However, if an injection of 20 seconds is increased by one second, the theoretical quantity is increased by only five percent.
- Variations in the time between the start of the chemical signal and the start of the chemical delivery into the machine can cause significant differences in the quantity of chemical injected. In this case, if a pump starts more slowly some times than others, or if the delivery tubes are partially empty at the start of the inject period, the quantity of chemical delivered may vary significantly. As an example, assume a peristaltic pump moves chemical along the delivery tube at a rate of three feet per second. If the delivery tube is empty for three feet along its length, then one second of the injection time is spent injecting air rather than chemical. If the programmed injection time is only three seconds, then one third of the desired chemical is not being delivered. However, if the programmed injection time is 20 seconds, the chemical delivery is only five percent less than desired.

Increasing the programmed injection time makes any variation less significant. Use pumps and/or valves sized to allow inject times of at least 10 seconds. If injection times for a specific chemical vary widely from one formula to another, consider using two pumps or valves for the same chemical. Actuate one pump for injecting small quantities, and use both pumps or valves for larger quantities.

1.4.1. Pump Signal Connections

The OneTouch® microprocessor controller used on Milnor® T_E, G_E, and similar models closes certain relay contacts when chemicals are desired and to flush the chemical system after each injection. These signals are 240 volts AC and cannot be made potential-free. Any device driven by this signal can draw up to 37 milliamperes.

Note 2: The manifold flush signal is effective only if the chemical supply system provided by others is properly designed and connected to a flushing water source.

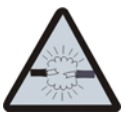

CAUTION 10: Component Damage Hazard—Board components will burn out and require board replacement if devices driven by inject signals do not meet the above electrical specifications. Pumps usually draw a higher current than specified above, and will cause board damage.

This machine provides signals for three chemicals and a manifold flush. Table 4 contains the connection details for these signals. All chemical signal connections are available on terminal strip TBS, as shown in Figure 4. This terminal strip is located in the electrical enclosure on the left rear of the machine, where the machine power connections are made.

Note 3: Unless the “Timer Stop” feature is employed, each chemical signal is enabled for 30 seconds, starting 15 seconds after the desired level (usually low level) is achieved for the bath.

Table 4: Chemical Injection Signals

| Signal Component | Chemical | Relay | Processor Board Connection | TBS Terminal Number |
|------------------|---------------------|-------|----------------------------|---------------------|
| Chemical 1 | Detergent | K13 | MTA6-7,8 | 1 |
| Chemical 2 | Bleach | K14 | MTA6-3,4 | 2 |
| Chemical 3 | Finishing chemicals | K15 | MTA6-1,2 | 3 |
| Manifold Flush | none | K12 | MTA6-9,10 | 4 |

Figure 4: Pump Signal Connections

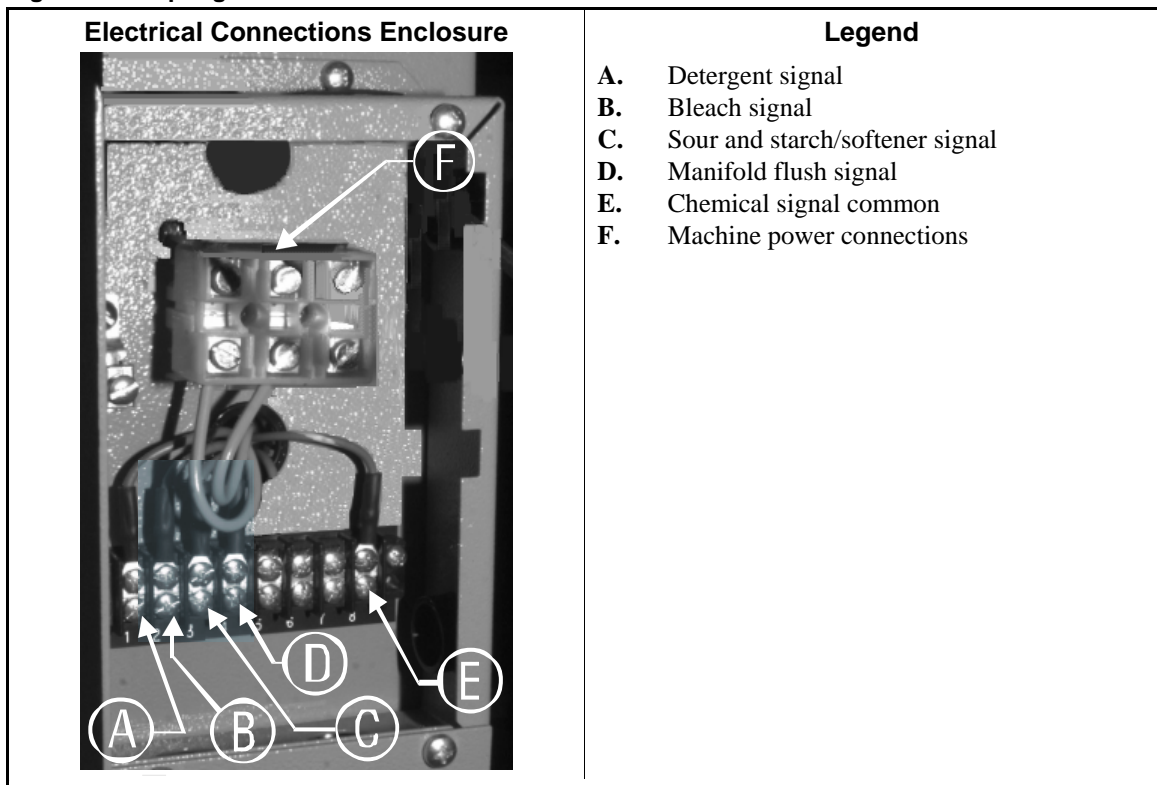

1.4.2. **Timer Stop Connections**

This feature is not available on coin-operated machines. *Timer stop* is a feature of the E-P OneTouch® control which stops the machine timer while a certain input to the microprocessor is grounded. When multiple machines without this feature are connected to a common chemical supply system, the quantity of chemical injected can vary widely if two or more machines request chemical simultaneously. When timer stop is properly wired with the chemical supply system, the supply system stops the timers in certain linked machines when one machine requests chemical.

When the chemical injection is completed, the chemical supply system terminates the *timer stop* command, and the stopped timers resume counting.

When the timer in a machine is stopped, the current formula event continues until the timer resumes counting. If water valves are open when the timer stops, they will close when the desired level is reached. Chemical injection signals will stop after the designated time, but the manifold flush signal will not occur until the timer starts. All other actions (cylinder reversing, extract speed, drain speed, etc.) that are in progress when the timer is stopped will continue until the timer starts again and the programmed time for the current event expires.

Milnor provides two wires terminated with butt connectors in the rear console of the machine, as shown in Figure 5. One wire originates electrically from pin 4 of MTA7 on processor board 08BT168AT, or pin 9 of MTA3 on processor board 08BT168BT. The other wire is electrically identical to pin 6 of MTS1 on the switch panel board. For *timer stop* to operate, the chemical system should include a normally open contact between these two connectors. When the contact is open, the machine runs normally. When the contact is closed, the machine timer stops until the contact opens again.

Figure 5: Timer Stop Connections

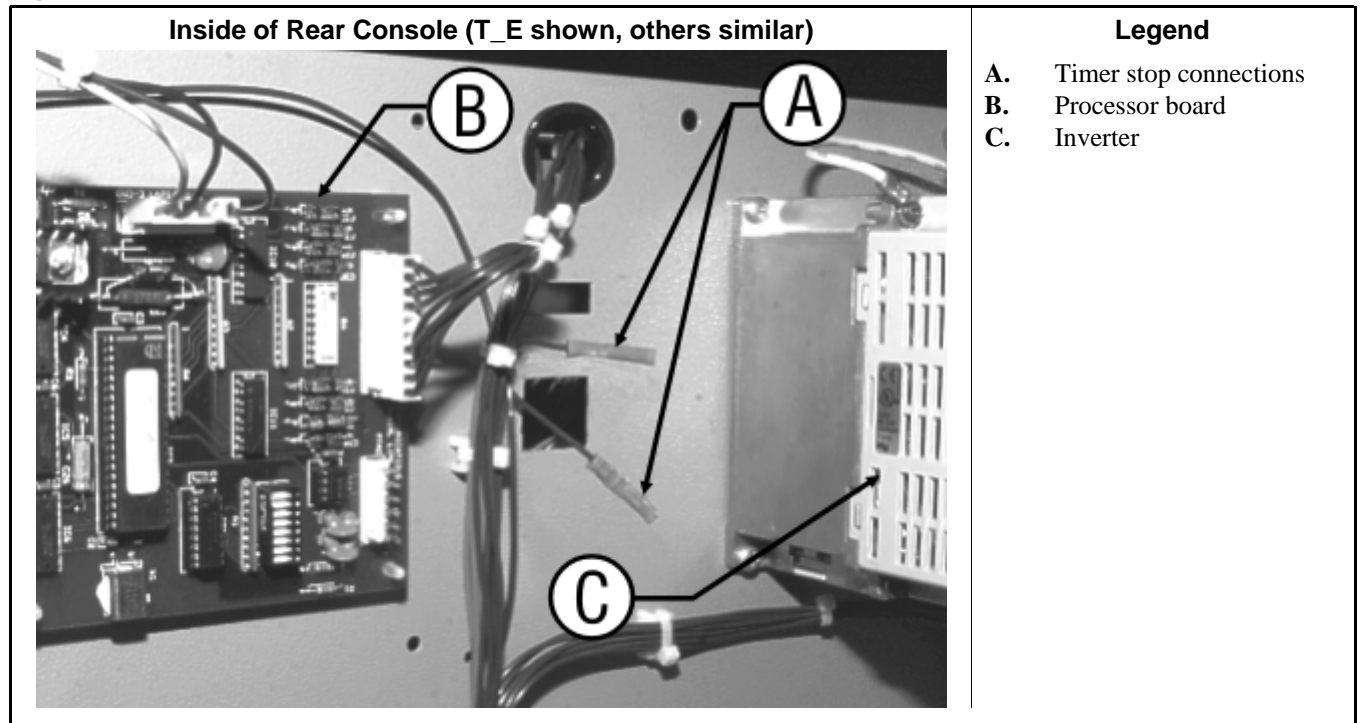

— End of BICEUI01 —

Chapter 2

Configuring

BICEUC01 (Published) Book specs- Dates: 20130909 / 20130909 / 20130909 Lang: ENG01 Applic: CEP

2.1. Configuring E-P OneTouch® Washer-extractor Models

The controller must be configured for your specific machine. Configuration information is controlled by a group of small switches (together called a DIP switch) on the processor board. When power is first applied to the machine, the microprocessor reads the *on* or *off* status of each switch.

2.1.1. Is this switch position ON or OFF?

You can set any DIP switch position to *on* or *off*. To turn a position **off**, you must either press down on the side of the switch nearest the word “OFF,” or slide the handle toward the position number. To turn a position “on,” you either press down on the side of the switch nearest the number, or slide the white handle toward the word “ON.” Use a pencil or a stiff wire to set the switch, which will click into position. See [Figure 6](#) for the DIP switch location.

Figure 6: Typical DIP switch on 08BT168AT

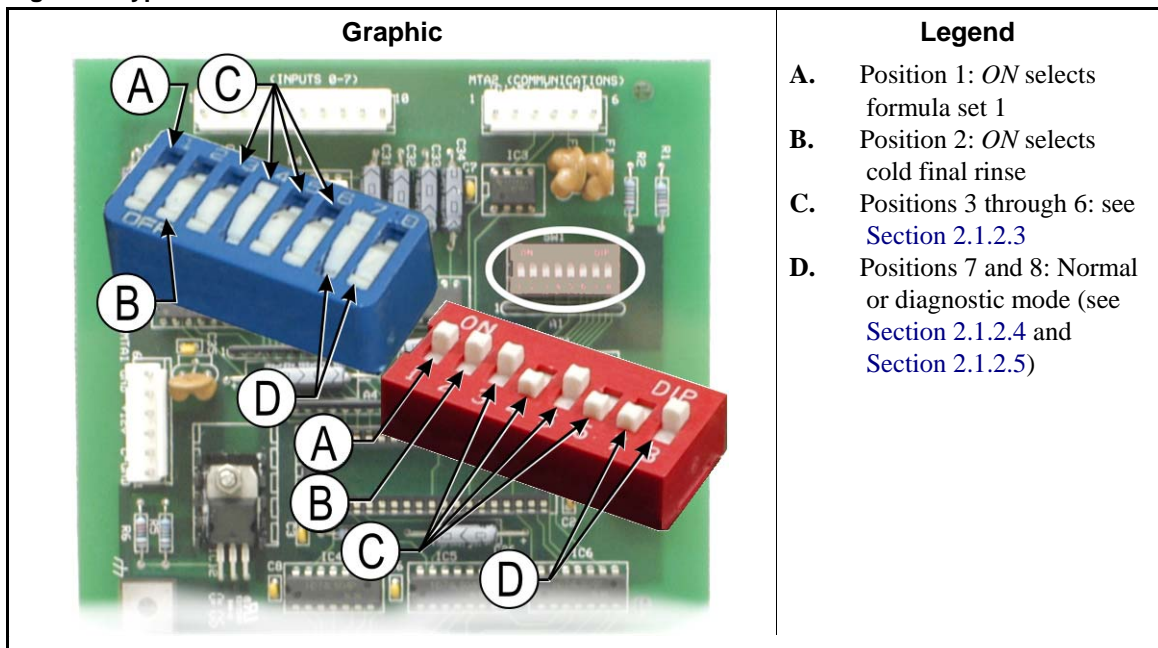

2.1.2. Configuration Decisions for Machines with Controller 08BT168AT or 98CMCR0911

- 2.1.2.1. Position 1: Use Formula Set #1?**—DIP switch position 1 determines the formula set used. Set this switch position *on* to configure the machine for the four primary formulas (Set #1), which are designed primarily for bed and bath linen. Set this switch *off* to use the alternate set of formulas (Set #2, primarily for kitchen/dining and personal goods). The formulas are listed in [Section 2.2. “Available E-P OneTouch® Wash Formulas \(softwares WUT5E1A and WUMWR1D\)”](#).
- 2.1.2.2. Position 2: Cold final rinse?**—In some locations the temperature of the incoming cold water may be too cold to allow the proper activation of some chemicals. In these locations, turn switch position 2 *off* to cause **both** water valves to open for all sour/softener steps.
- 2.1.2.3. Positions 3 through 6: Formula Set Selection**—DIP switch positions 3, 4, 5, and 6 set which formula set is available. **Set only one of these switches *on*.** All formula sets are described in [Section 2.2. “Available E-P OneTouch® Wash Formulas \(softwares WUT5E1A and WUMWR1D\)”](#). See [Section 2.1.2.1](#) to choose Formula Set #1 or #2 of any group below.
- 2.1.2.3.1. **Standard Formulas for Hotel and Hospitality**—Set switch position 3 *on* and switch positions 4, 5, and 6 *off* to use the formulas shown in [Section 2.2.1.1](#).
- 2.1.2.3.2. **GreenTurn Formulas for Hotel and Hospitality**—Set switch position 4 *on* and switch positions 3, 5, and 6 *off* to use the formulas shown in [Section 2.2.1.2](#).
- 2.1.2.3.3. **Standard Formulas for Healthcare**—Set switch position 5 *on* and switch positions 3, 4, and 6 *off* to use the formulas shown in [Section 2.2.2.1](#).
- 2.1.2.3.4. **GreenTurn Formulas for Healthcare**—Set switch position 6 *on* and switch positions 3, 4, and 5 *off* to use the formulas shown in [Section 2.2.2.2](#).
- 2.1.2.4. Position 7: Normal operation?**—The Milnor factory sets switch position 7 *off* when preparing and testing the board before installation. **Set this switch position *on* before first commissioning the machine, or before installing this board as a replacement board.** The machine will not enter the diagnostics mode if this position is *on*.
- 2.1.2.5. Position 8: Run formulas?**—Switch position 8 determines whether the machine is configured for normal operation or for diagnostics. With this position *on*, the machine operates normally by running formulas. **Verify that this switch position is *on* before first commissioning the machine, or before installing a replacement board.**

When switch position 8 is *off*, the machine is configured for diagnostics. In this configuration, an optional display can be connected to the processor board to aid in diagnosing problems when a qualified technician manually actuates individual outputs.

— End of BICEUC01 —

2.2. Available E-P OneTouch® Wash Formulas (softwares WUT5E1A and WUMWR1D)

2.2.1. Hotel and Hospitality Configuration [Document BICEUP07]

2.2.1.1. Standard Formulas for Hotel and Hospitality

Table 5: Standard Formula Set #1

| Operation | Formula A: Blankets and Spreads | | | | Formula B: Sheets | | | | Formula C: Towels | | | | Formula D: White Heavy Soil | | | |
|---|---------------------------------|---|-----------|---------------|-------------------|----|-----------|---------------|-------------------|---|-----------|------|-----------------------------|---|-----------|-------|
| | Time | | Chemicals | | Time | | Chemicals | | Time | | Chemicals | | Time | | Chemicals | |
| | | | | Temp | | | | Temp | | | | Temp | | | | Level |
| Flush | | | | | | | | | | | | | 2 | | S | Hi |
| Drain | | | | | | | | | | | | | 1.25 | | | |
| Bath | 8 | D | S | Lo | 10 | DB | H | Lo | 7 | D | H | Lo | 10 | D | H | Lo |
| Drain | 1.25 | | | | 1.25 | | | | 1.25 | | | | 1.25 | | | |
| Rinse | 2 | | S | Hi | 2 | | H | Hi | | | | | | | | |
| Drain | 1.25 | | | | 1.25 | | | | | | | | | | | |
| Bath | | | | | | | | | 7 | B | H | Lo | 7 | B | H | Lo |
| Drain | | | | | | | | | 1.25 | | | | 1.25 | | | |
| Rinse | 2 | | C | Hi | | | | | 2 | | H | Hi | 2 | | H | Hi |
| Drain | 1.25 | | | | | | | | 1.25 | | | | 1.25 | | | |
| Extract | | | | | 1 | | | | 1 | | | | 1 | | | |
| Coast | | | | | 1.25 | | | | 1.25 | | | | 1.25 | | | |
| Rinse | | | | | 2 | | | | 2 | | S | Hi | 2 | | S | Hi |
| Drain | | | | | 1.25 | | | | 1.25 | | | | 1.25 | | | |
| Extract | | | | | 1 | | | | 1 | | | | 1 | | | |
| Coast | | | | | 1.25 | | | | 1.25 | | | | 1.25 | | | |
| Bath | 4 | F | C | Lo | 4 | F | C | Lo | 4 | F | C | Lo | 4 | F | C | Lo |
| Note: A DIP switch setting allows configuring this operation for split fill. | | | | | | | | | | | | | | | | |
| Drain | 1.25 | | | | 1.25 | | | | 1.25 | | | | 1.25 | | | |
| Extract | 7 | | | | 6 | | | | 7 | | | | 7 | | | |
| Coast | 1.25 | | | | 1.25 | | | | 1.25 | | | | 1.25 | | | |
| Run Time | 29.25 | | | | 34.75 | | | | 41 | | | | 47.25 | | | |
| Key to Abbreviations: | | | | | | | | | | | | | | | | |
| D Usually detergent | | | | H Hot water | | | | Hi High level | | | | | | | | |
| B Usually bleach | | | | C Cold water | | | | Lo Low level | | | | | | | | |
| F Sour/softener or sour/starch | | | | S Split water | | | | | | | | | | | | |
| Notes: | | | | | | | | | | | | | | | | |
| 1 For any bath step, the timer does not run until the desired level is achieved. | | | | | | | | | | | | | | | | |

Table 6: Standard Formula Set #2

| Operation | Formula A: Colored 100% Poly Table Linen | | | | Formula B: White 100% Poly Table Linen | | | | Formula C: Stain Treatment | | | | Formula D: White Kitchen Goods | | | |
|---|--|--|-------|----|--|-------------|-------|----|----------------------------|------------|-------|----|--------------------------------|-----------|-------|----|
| | Time | Chemicals | | | Time | Chemicals | | | Time | Chemicals | | | Time | Chemicals | | |
| | | Temp | Level | | | Temp | Level | | | Temp | Level | | | Temp | Level | |
| Bath | 10 | D | H | Lo | 10 | D | H | Lo | 20 | DB | H | Lo | 5 | D | H | Lo |
| Carryover | | | | | | | | | | | | | 1 | | H | Hi |
| Drain | 1.25 | | | | 1.25 | | | | 1.25 | | | | 1.25 | | | |
| Rinse | 2 | | H | | | | | | 2 | | H | Hi | | | | |
| Drain | 1.25 | | | | | | | | 1.25 | | | | | | | |
| Bath | | | | | 7 | B | H | Lo | | | | | 8 | D | H | Lo |
| Drain | | | | | 1.25 | | | | | | | | 1.25 | | | |
| Rinse | 2 | | S | Hi | 2 | | S | Hi | 2 | | H | Hi | 2 | | H | Hi |
| Drain | 1.25 | | | | 1.25 | | | | 1.25 | | | | 1.25 | | | |
| Bath | | | | | | | | | | | | | 7 | B | H | Lo |
| Drain | | | | | | | | | | | | | 1.25 | | | |
| Rinse | 2 | | S | Hi | 2 | | S | Hi | 2 | | S | Hi | 2 | | S | Hi |
| Drain | 1.25 | | | | 1.25 | | | | 1.25 | | | | 1.25 | | | |
| Extract | | | | | | | | | 1 | | | | 1 | | | |
| Coast | | | | | | | | | 1.25 | | | | 1.25 | | | |
| Rinse | | | | | | | | | 2 | | S | Hi | 2 | | S | Hi |
| Drain | | | | | | | | | | | | | 1.25 | | | |
| Bath | 4 | F | C | Lo | 4 | F | C | Lo | | | | | 4 | F | C | Lo |
| Note: A DIP switch setting allows configuring this operation for split fill. | | | | | | | | | | | | | | | | |
| Drain | 1.25 | | | | 1.25 | | | | 1.25 | | | | 1.25 | | | |
| Extract | 2.5 | | | | 2.5 | | | | 7 | | | | 7 | | | |
| Coast | 1.25 | | | | 1.25 | | | | 1.25 | | | | 1.25 | | | |
| Run Time | 30 | | | | 35 | | | | 42.75 | | | | 50.25 | | | |
| Key to Abbreviations: | | | | | | | | | | | | | | | | |
| | D | Usually detergent | | | H | Hot water | | | Hi | High level | | | | | | |
| | B | Usually bleach | | | C | Cold water | | | Lo | Low level | | | | | | |
| | F | Sour/softener or sour/starch | | | S | Split water | | | | | | | | | | |
| Notes: | | | | | | | | | | | | | | | | |
| | 1 | For any bath step, the timer does not run until the desired level is achieved. | | | | | | | | | | | | | | |

2.2.1.2. GreenTurn™ Formulas for Hotel and Hospitality

Table 7: GreenTurn™ Formula Set #1

| Operation | Formula A: Blankets and Spreads | | | | Formula B: Sheets | | | | Formula C: Towels | | | | Formula D: White Heavy Soil | | | |
|---|---------------------------------|--|-----------|-------|-------------------|-------------|-----------|-------|-------------------|------------|-----------|-------|-----------------------------|---|-----------|-------|
| | Time | | Chemicals | | Time | | Chemicals | | Time | | Chemicals | | Time | | Chemicals | |
| | | | Temp | Level | | | Temp | Level | | | Temp | Level | | | Temp | Level |
| Flush | | | | | | | | | | | | | 2 | | S | Hi |
| Drain | | | | | | | | | | | | | 1.25 | | | |
| Bath | 6 | D | C | Lo | 8 | DB | H | Lo | 6 | D | H | Lo | 8 | D | H | Lo |
| Drain | 1.25 | | | | 1.25 | | | | 1.25 | | | | 1.25 | | | |
| Rinse | 2 | | C | Hi | 2 | | H | Hi | | | | | | | | |
| Drain | 1.25 | | | | 1.25 | | | | | | | | | | | |
| Bath | | | | | | | | | 6 | B | H | Lo | 7 | B | H | Lo |
| Drain | | | | | | | | | 1.25 | | | | 1.25 | | | |
| Rinse | | | | | | | | | 2 | | H | Hi | 2 | | H | Hi |
| Drain | | | | | | | | | 1.25 | | | | 1.25 | | | |
| Extract | | | | | 1 | | | | 1 | | | | 1 | | | |
| Coast | | | | | 1.25 | | | | 1.25 | | | | 1.25 | | | |
| Bath | 4 | F | C | Lo | 4 | F | C | Lo | 4 | F | C | Lo | 4 | F | C | Lo |
| Note: A DIP switch setting allows configuring this operation for split fill. | | | | | | | | | | | | | | | | |
| Drain | 1.25 | | | | 1.25 | | | | 1.25 | | | | 1.25 | | | |
| Extract | 7 | | | | 6 | | | | 7 | | | | 7 | | | |
| Coast | 1.25 | | | | 1.25 | | | | 1.25 | | | | 1.25 | | | |
| Run Time | 24 | | | | 27.25 | | | | 33.5 | | | | 39.75 | | | |
| Key to Abbreviations: | | | | | | | | | | | | | | | | |
| | D | Usually detergent | | | H | Hot water | | | Hi | High level | | | | | | |
| | B | Usually bleach | | | C | Cold water | | | Lo | Low level | | | | | | |
| | F | Sour/softener or sour/starch | | | S | Split water | | | | | | | | | | |
| Notes: | | | | | | | | | | | | | | | | |
| | 1 | For any bath step, the timer does not run until the desired level is achieved. | | | | | | | | | | | | | | |

Table 8: GreenTurn™ Formula Set #2

| Operation | Formula A: Colored 100% Poly Table Linen | | | | Formula B: White 100% Poly Table Linen | | | | Formula C: Stain Treatment | | | | Formula D: White Kitchen Goods | | | | | |
|---|--|--|-----------|-------|--|---|-------------|------|----------------------------|----|-----------|------------|--------------------------------|-------|-----------|------|--|-------|
| | Time | | Chemicals | | Time | | Chemicals | | Time | | Chemicals | | Time | | Chemicals | | | |
| | | | | Temp | | | | Temp | | | | Temp | | | | Temp | | |
| | | | | Level | | | | | Level | | | | | Level | | | | Level |
| Bath | 8 | D | H | Lo | 8 | D | H | Lo | 15 | DB | H | Lo | 5 | D | H | Lo | | |
| Carryover | | | | | | | | | | | | | 1 | | H | Hi | | |
| Drain | 1.25 | | | | 1.25 | | | | 1.25 | | | | 1.25 | | | | | |
| Rinse | | | | | | | | | 2 | | H | Hi | | | | | | |
| Drain | | | | | | | | | 1.25 | | | | | | | | | |
| Bath | | | | | 7 | B | H | Lo | | | | | 8 | D | H | Lo | | |
| Drain | | | | | 1.25 | | | | | | | | 1.25 | | | | | |
| Rinse | 2 | | S | Hi | 2 | | S | Hi | 2 | | H | Hi | 2 | | H | Hi | | |
| Drain | 1.25 | | | | 1.25 | | | | 1.25 | | | | 1.25 | | | | | |
| Bath | | | | | | | | | | | | | 7 | B | H | Lo | | |
| Drain | | | | | | | | | | | | | 1.25 | | | | | |
| Rinse | | | | | | | | | 2 | | S | Hi | 2 | | S | Hi | | |
| Drain | | | | | | | | | 1.25 | | | | 1.25 | | | | | |
| Extract | | | | | | | | | 1 | | | | 1 | | | | | |
| Coast | | | | | | | | | 1.25 | | | | 1.25 | | | | | |
| Rinse | | | | | | | | | 2 | | S | Hi | | | | | | |
| Drain | | | | | | | | | | | | | | | | | | |
| Bath | 4 | F | C | Lo | 4 | F | C | Lo | | | | | 4 | F | C | Lo | | |
| Note: A DIP switch setting allows configuring this operation for split fill. | | | | | | | | | | | | | | | | | | |
| Drain | 1.25 | | | | 1.25 | | | | 1.25 | | | | 1.25 | | | | | |
| Extract | 2.5 | | | | 2.5 | | | | 7 | | | | 7 | | | | | |
| Coast | 1.25 | | | | 1.25 | | | | 1.25 | | | | 1.25 | | | | | |
| Run Time | 21.5 | | | | 29.75 | | | | 39.75 | | | | 57 | | | | | |
| Key to Abbreviations: | | | | | | | | | | | | | | | | | | |
| | D | Usually detergent | | | | H | Hot water | | | | Hi | High level | | | | | | |
| | B | Usually bleach | | | | C | Cold water | | | | Lo | Low level | | | | | | |
| | F | Sour/softener or sour/starch | | | | S | Split water | | | | | | | | | | | |
| Notes: | | | | | | | | | | | | | | | | | | |
| | 1 | For any bath step, the timer does not run until the desired level is achieved. | | | | | | | | | | | | | | | | |

2.2.2. Healthcare Configuration [Document BICEUP08]

2.2.2.1. Standard Formulas for Healthcare

Table 9: Standard Formula Set #1

| Operation | Formula A: Blankets and Spreads | | | | Formula B: Sheets | | | | Formula C: Towels | | | | Formula D: Diapers and Pads | | | | |
|---|---------------------------------|--|-------|----|-------------------|-----------|-------|-------------|-------------------|-----------|-------|----|-----------------------------|------------|-------|----|--|
| | Time | Chemicals | | | Time | Chemicals | | | Time | Chemicals | | | Time | Chemicals | | | |
| | | Temp | Level | | | Temp | Level | | | Temp | Level | | | Temp | Level | | |
| Flush | | | | | 2 | | S | Hi | 2 | | S | Hi | 3 | | S | Hi | |
| Drain | | | | | 1.25 | | | | 1.25 | | | | 1.25 | | | | |
| Bath | 8 | D | S | Lo | | | | | | | | | | | | | |
| Flush | | | | | 2 | | S | Hi | 2 | | S | Hi | 2 | | S | Hi | |
| Drain | 1.25 | | | | 1.25 | | | | 1.25 | | | | 1.25 | | | | |
| Flush | | | | | | | | | | | | | 2 | | S | Hi | |
| Rinse | 2 | | S | Hi | | | | | | | | | | | | | |
| Drain | 1.25 | | | | | | | | | | | | 1.25 | | | | |
| Bath | | | | | 7 | D | H | Lo | 7 | D | H | Lo | 7 | D | H | Lo | |
| Drain | | | | | 1.25 | | | | | | | | 1.25 | | | | |
| Carryover | | | | | | | | | 1 | | H | Hi | | | | | |
| Rinse | 2 | | C | Hi | | | | | | | | | 2 | | H | Hi | |
| Drain | 1.25 | | | | | | | | 1.25 | | | | 1.25 | | | | |
| Bath | | | | | 7 | B | H | Lo | 7 | B | H | Lo | 7 | B | H | Lo | |
| Drain | | | | | 1.25 | | | | 1.25 | | | | 1.25 | | | | |
| Rinse | | | | | 2 | | S | Hi | 2 | | S | Hi | 2 | | S | Hi | |
| Drain | | | | | 1.25 | | | | 1.25 | | | | 1.25 | | | | |
| Rinse | | | | | 2 | | S | Hi | 2 | | S | Hi | 2 | | S | Hi | |
| Drain | | | | | 1.25 | | | | 1.25 | | | | 1.25 | | | | |
| Bath | 4 | F | C | Lo | 4 | F | C | Lo | 4 | F | C | Lo | 4 | F | C | Lo | |
| Note: A DIP switch setting allows configuring this operation for split fill. | | | | | | | | | | | | | | | | | |
| Drain | 1.25 | | | | 1.25 | | | | 1.25 | | | | 1.25 | | | | |
| Extract | 7 | | | | 6 | | | | 7 | | | | 7 | | | | |
| Coast | 1.25 | | | | 1.25 | | | | 1.25 | | | | 1.25 | | | | |
| Run Time | 29.25 | | | | 42 | | | | 44 | | | | 50.5 | | | | |
| Key to Abbreviations: | | | | | | | | | | | | | | | | | |
| | D | Usually detergent | | | | | H | Hot water | | | | | Hi | High level | | | |
| | B | Usually bleach | | | | | C | Cold water | | | | | Lo | Low level | | | |
| | F | Sour/softener or sour/starch | | | | | S | Split water | | | | | | | | | |
| Notes: | | | | | | | | | | | | | | | | | |
| | 1 | For any bath step, the timer does not run until the desired level is achieved. | | | | | | | | | | | | | | | |

Table 10: Standard Formula Set #2

| Operation | Formula A: Personal Goods | | | | Formula B: White 100% Poly Table Linen | | | | Formula C: Stain Treatment | | | | Formula D: White Heavy Soil | | | | | |
|---|---------------------------|--|-----------|-------|--|---|-------------|------|----------------------------|----|-----------|------------|-----------------------------|-------|-----------|------|--|-------|
| | Time | | Chemicals | | Time | | Chemicals | | Time | | Chemicals | | Time | | Chemicals | | | |
| | | | | Temp | | | | Temp | | | | Temp | | | | Temp | | |
| | | | | Level | | | | | Level | | | | | Level | | | | Level |
| Flush | 2 | | S | Hi | | | | | | | | | | | | | | |
| Drain | 1.25 | | | | | | | | | | | | | | | | | |
| Bath | 7 | D | H | Lo | 10 | D | H | Lo | 20 | DB | H | Lo | 10 | D | H | Lo | | |
| Drain | 1.25 | | | | 1.25 | | | | 1.25 | | | | 1.25 | | | | | |
| Rinse | 2 | | H | Hi | | | | | 2 | | H | Hi | | | | | | |
| Drain | 1.25 | | | | | | | | 1.25 | | | | | | | | | |
| Bath | | | | | 7 | B | H | Lo | | | | | 7 | B | H | Lo | | |
| Drain | | | | | 1.25 | | | | | | | | 1.25 | | | | | |
| Rinse | 2 | | S | Hi | 2 | | S | Hi | 2 | | H | Hi | 2 | | H | Hi | | |
| Drain | 1.25 | | | | 1.25 | | | | 1.25 | | | | 1.25 | | | | | |
| Extract | | | | | | | | | | | | | 1 | | | | | |
| Coast | | | | | | | | | | | | | 1.25 | | | | | |
| Rinse | 2 | | S | Hi | 2 | | S | Hi | 2 | | S | Hi | 2 | | S | Hi | | |
| Drain | 1.25 | | | | 1.25 | | | | 1.25 | | | | 1.25 | | | | | |
| Extract | | | | | | | | | 1 | | | | 1 | | | | | |
| Coast | | | | | | | | | 1.25 | | | | 1.25 | | | | | |
| Bath | 4 | F | C | Lo | 4 | F | C | Lo | 2 | | C | Hi | 4 | F | C | Lo | | |
| Note: A DIP switch setting allows configuring this operation for split fill. | | | | | | | | | | | | | | | | | | |
| Drain | 1.25 | | | | 1.25 | | | | 1.25 | | | | 1.25 | | | | | |
| Extract | 6 | | | | 2.5 | | | | 7 | | | | 7 | | | | | |
| Coast | 1.25 | | | | 1.25 | | | | 1.25 | | | | 1.25 | | | | | |
| Run Time | 33.75 | | | | 35 | | | | 44.75 | | | | 47.25 | | | | | |
| Key to Abbreviations: | | | | | | | | | | | | | | | | | | |
| | D | Usually detergent | | | | H | Hot water | | | | Hi | High level | | | | | | |
| | B | Usually bleach | | | | C | Cold water | | | | Lo | Low level | | | | | | |
| | F | Sour/softener or sour/starch | | | | S | Split water | | | | | | | | | | | |
| Notes: | | | | | | | | | | | | | | | | | | |
| | 1 | For any bath step, the timer does not run until the desired level is achieved. | | | | | | | | | | | | | | | | |

2.2.2.2. GreenTurn™ Formulas for Healthcare

Table 11: GreenTurn™ Formula Set #1

| Operation | Formula A: Blankets and Spreads | | | | Formula B: Sheets | | | | Formula C: Towels | | | | Formula D: Diapers and Pads | | | |
|---|---------------------------------|--|-------|----|-------------------|-----------|-------------|----|-------------------|-----------|-------|------------|-----------------------------|-----------|-------|----|
| | Time | Chemicals | | | Time | Chemicals | | | Time | Chemicals | | | Time | Chemicals | | |
| | | Temp | Level | | | Temp | Level | | | Temp | Level | | | Temp | Level | |
| Flush | | | | | 2 | S | Hi | | 2 | S | Hi | | 3 | S | Hi | |
| Drain | | | | | 1.25 | | | | 1.25 | | | | 1.25 | | | |
| Bath | 6 | D | S | Lo | | | | | | | | | | | | |
| Flush | | | | | 2 | S | Hi | | 2 | S | Hi | | 2 | S | Hi | |
| Drain | 1.25 | | | | 1.25 | | | | 1.25 | | | | 1.25 | | | |
| Flush | | | | | | | | | | | | | 2 | S | Hi | |
| Rinse | 2 | | S | Hi | | | | | | | | | | | | |
| Drain | 1.25 | | | | | | | | | | | | 1.25 | | | |
| Bath | | | | | 5 | D | H | Lo | 5 | D | H | Lo | 5 | D | H | Lo |
| Drain | | | | | 1.25 | | | | | | | | 1.25 | | | |
| Carryover | | | | | | | | | 1 | | H | Hi | | | | |
| Rinse | 2 | | C | Hi | | | | | | | | | 2 | | H | Hi |
| Drain | 1.25 | | | | | | | | 1.25 | | | | 1.25 | | | |
| Bath | | | | | 5 | B | H | Lo | 5 | B | H | Lo | 5 | B | H | Lo |
| Drain | | | | | | | | | | | | | 1.25 | | | |
| Rinse | | | | | | | | | | | | | 2 | S | Hi | |
| Drain | | | | | 1.25 | | | | 1.25 | | | | 1.25 | | | |
| Rinse | | | | | 2 | S | Hi | | 2 | S | Hi | | 2 | S | Hi | |
| Drain | | | | | 1.25 | | | | 1.25 | | | | 1.25 | | | |
| Bath | 4 | F | C | Lo | 4 | F | C | Lo | 4 | F | C | Lo | 4 | F | C | Lo |
| Note: A DIP switch setting allows configuring this operation for split fill. | | | | | | | | | | | | | | | | |
| Drain | 1.25 | | | | 1.25 | | | | 1.25 | | | | 1.25 | | | |
| Extract | 7 | | | | 6 | | | | 7 | | | | 7 | | | |
| Coast | 1.25 | | | | 1.25 | | | | 1.25 | | | | 1.25 | | | |
| Run Time | 27.25 | | | | 36.75 | | | | 36.75 | | | | 46.5 | | | |
| Key to Abbreviations: | | | | | | | | | | | | | | | | |
| | D | Usually detergent | | | | H | Hot water | | | | Hi | High level | | | | |
| | B | Usually bleach | | | | C | Cold water | | | | Lo | Low level | | | | |
| | F | Sour/softener or sour/starch | | | | S | Split water | | | | | | | | | |
| Notes: | | | | | | | | | | | | | | | | |
| | 1 | For any bath step, the timer does not run until the desired level is achieved. | | | | | | | | | | | | | | |

Table 12: GreenTurn™ Formula Set #2

| Operation | Formula A: Personal Goods | | | | Formula B: White 100% Poly Table Linen | | | | Formula C: Stain Treatment | | | | Formula D: White Heavy Soil | | | | | |
|---|---------------------------|-----------|-------|-------|--|-----------|-------|-------|----------------------------|---------------|-------|-------|-----------------------------|-----------|-------|-------|---|----|
| | Time | Chemicals | | | Time | Chemicals | | | Time | Chemicals | | | Time | Chemicals | | | | |
| | | Temp | Level | Level | | Temp | Level | Level | | Temp | Level | Level | | Temp | Level | Level | | |
| Flush | 2 | | S | Hi | | | | | | | | | | | 2 | | S | Hi |
| Drain | 1.25 | | | | | | | | | | | | | | 1.25 | | | |
| Bath | 5 | D | H | Lo | 8 | D | H | Lo | 15 | DB | H | Lo | 8 | D | H | Lo | | |
| Drain | 1.25 | | | | 1.25 | | | | 1.25 | | | | 1.25 | | | | | |
| Rinse | 2 | | H | Hi | | | | | 2 | | H | Hi | | | | | | |
| Drain | 1.25 | | | | | | | | 1.25 | | | | | | | | | |
| Bath | | | | | 6.5 | B | H | Lo | | | | | 5 | B | H | Lo | | |
| Drain | | | | | 1.25 | | | | | | | | 1.25 | | | | | |
| Rinse | 2 | | S | Hi | 2 | | S | Hi | 2 | | H | Hi | 2 | | H | Hi | | |
| Drain | 1.25 | | | | 1.25 | | | | 1.25 | | | | 1.25 | | | | | |
| Extract | | | | | | | | | | | | | 1 | | | | | |
| Coast | | | | | | | | | | | | | 1.25 | | | | | |
| Rinse | | | | | | | | | 2 | | S | Hi | 2 | | S | Hi | | |
| Drain | | | | | | | | | 1.25 | | | | 1.25 | | | | | |
| Extract | | | | | | | | | 1 | | | | 1 | | | | | |
| Coast | | | | | | | | | 1.25 | | | | 1.25 | | | | | |
| Bath | 4 | F | C | Lo | 4 | F | C | Lo | 2 | | C | Hi | 4 | F | C | Lo | | |
| Note: A DIP switch setting allows configuring this operation for split fill. | | | | | | | | | | | | | | | | | | |
| Drain | 1.25 | | | | 1.25 | | | | 1.25 | | | | 1.25 | | | | | |
| Extract | 6 | | | | 2.5 | | | | 7 | | | | 7 | | | | | |
| Coast | 1.25 | | | | 1.25 | | | | 1.25 | | | | 1.25 | | | | | |
| Run Time | 28.5 | | | | 29.25 | | | | 39.75 | | | | 43.25 | | | | | |
| Key to Abbreviations: | | | | | | | | | | | | | | | | | | |
| D Usually detergent | | | | | H Hot water | | | | | Hi High level | | | | | | | | |
| B Usually bleach | | | | | C Cold water | | | | | Lo Low level | | | | | | | | |
| F Sour/softener or sour/starch | | | | | S Split water | | | | | | | | | | | | | |
| Notes: | | | | | | | | | | | | | | | | | | |
| 1 For any bath step, the timer does not run until the desired level is achieved. | | | | | | | | | | | | | | | | | | |

Chapter 3

Operating

BIWU001 (Published) Book specs- Dates: 20130909 / 20130909 / 20130909 Lang: ENG01 Applic: CEP

3.1. Determining Load Size

Putting **too much** linen into a properly designed laundry washer-extractor will not **overload** the machine to its mechanical or electrical detriment if these guidelines are followed:

1. The goods consist of typical cotton and/or synthetic fabrics normally encountered in commercial laundering operations.
2. The load is not so bulky as to prevent a reasonably balanced distribution prior to the onset of extraction.
3. The extract speed has not been increased above the designed maximum.
4. The total number of intermediate and final extractions do not exceed the designed maximum for the extract motor.

Thus, the *maximum soiled linen capacity* for any properly designed washer-extractor is essentially limited by the amount of soiled goods that can actually be placed in the cylinder.

The maximum weight of soiled goods that a washer-extractor cylinder will accept depends on the following factors:

- the internal volume of the cylinder (the space into which the goods can be placed), and
- the density (weight and bulkiness) of the specific goods

For example, many polyester-cotton fabrics have relatively low weights for their bulk so one should rarely expect to be able to put in a published maximum capacity load of such fabrics. In fact, published maximum capacities of machines based on the now generally accepted industry standards will usually be achieved only with the highest density, closely woven fabrics and a reasonable soil content.

The best load size depends on the size of the machine—plus the type of goods, soil content, and wash quality desired. Since the latter factors vary considerably, prior experience and/or experimentation generally yield the best results. Use these guidelines:

1. Overloading a washer-extractor will not increase production because longer wash formulas and more rewash will be required.
2. Avoid underloads because the inevitable greater extraction imbalance will cause more extract re-cycles and may stress the machine unnecessarily.

— End of BIWU001 —

3.2. Controls on E-P OneTouch® Model Washer-extractors

Most of the controls on Milnor® E-P OneTouch® washer-extractors are membrane push-buttons. Other controls include a mechanical push-button to unlock the door latch, and two lights to indicate that the machine is running and when the machine is nearing the end of a formula.

Figure 7: E-P OneTouch® Controls

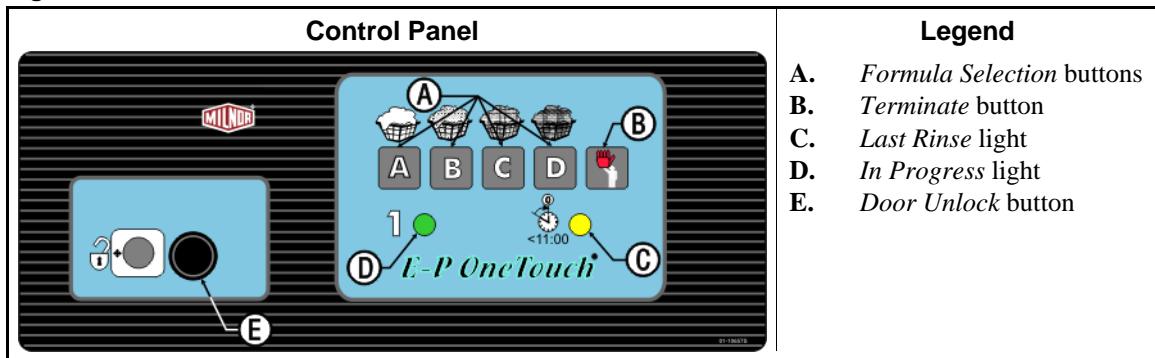

3.2.1. Control Functions During Normal Operation

3.2.1.1. Formula Selection Buttons—The E-P OneTouch® controller provides four pre-programmed formulas that vary according to machine configuration. Start the desired formula by pressing the corresponding *Formula Selection* button (A, B, C, or D) with the machine loaded and the door closed.

Consult with your chemical supplier for the specific formula to use with each type of goods being processed.

3.2.1.2. Terminate Button—The *Terminate* button (B) ends any running formula. When a formula is ended early, you must restart it from the beginning by pressing one of the the *Formula Selection* buttons with the door closed.

3.2.1.3. Last Rinse Light—This light comes on when the last bath step of any formula begins and remains on until the formula ends. If the operator needs to add a chemical during the last bath, such as softener, he should add it as soon as this light comes on. The *Last Rinse* light also alerts the operator that the machine will soon be ready for unloading.

If an error occurs during a formula, this light and the *In Progress* light flash (two seconds on, then two seconds off) for 10 minutes. After 10 minutes, both lights go off. The error can be a malfunction of either the door lock circuit or the inverter. In either case, all machine controls are locked out for 75 seconds to ensure that the cylinder has coasted to a stop. To open the door after an error occurs, press the *Terminate* button (B) to clear the error condition, then hold the *Door Unlock* button (E) and turn the door latch handle.

3.2.1.4. In Progress Light—When power is first applied to the machine, this light flashes for 75 seconds to indicate that the power-up delay timer is counting down. The light goes off when the power-up delay expires.

This light is constantly *on* when a formula starts (the door is closed and a formula selection button is pressed). It remains on until the formula ends normally, is terminated by the operator, or an error occurs.

If the formula ends normally by running to completion, the *In Progress* light goes off when the last step of the formula ends. If the operator terminates a formula, this light flashes (two seconds on, then two seconds off) for 75 seconds as the coast timer counts down. After 75 seconds, hold the *Door Unlock* button (Ⓜ) and turn the door latch handle to open the door.

- 3.2.1.5. Door Unlock Button**—This button activates a solenoid in the door latch which unlocks the door latch handle, allowing the operator to open the door. To lessen the chance of injury caused by opening the door while the basket is turning, the microprocessor controller disables this button when a formula starts.

The *Door Unlock* button is disabled for 75 seconds after a formula ends, whether the formula ended normally, was ended early by the operator, or ended because of an error.

3.2.2. Control Functions During Testing

Do not attempt to test or troubleshoot a malfunctioning machine using only the information in this document. For complete testing procedures, see [Section 4.1. “Troubleshooting Errors”](#).

The display kit referenced in [Section 3.2.2.1](#) consists primarily of a vacuum fluorescent display and a wiring harness to temporarily connect the display to the processor board for testing by authorized, qualified technicians. This kit is available from Milnor (see [Section ii. “Contacting Milnor®”](#)).

3.2.2.1. Formula Selection Buttons

- 3.2.2.1.1. Formula A button (ⓐ)**—With the display kit attached and the machine in *normal operation* mode (DIP switch position 8 is *on*), this button stops the formula timer as long as it is held depressed. The timer resumes running when the button is released. Hold this button to simulate the *timer stop* feature. *Timer stop* is used by some chemical injection systems to pause a running formula until the appropriate chemical injection is completed. This feature is described in more detail in [Section 1.4.2](#).

| Display or Action | Explanation |
|---|---|
| F:A EQ:003 CE:000 Level A1/D1 T-Run | Typical display in <i>normal operation</i> mode before button ⓐ is pressed. |
| F:A EQ:003 CE:000 Level A1/D1 T-Stop | Typical display in <i>normal operation</i> mode with button ⓐ held depressed. |

If the machine is in *testing* mode (DIP switch position 8 is *off* and position 2 is *on*), this button makes *input A* on the testing display and enables the next numerical output. Holding ⓐ depressed causes the controller to turn each output *on* for about one half second, then *off* before advancing automatically and testing the next output in the sequence.

Note 4: For safety, the controller allows only one output to be turned on at a time in testing mode.

- 3.2.2.1.2. Formula B button (ⓑ)**—This button is ignored if the machine is in *normal operation* mode and a formula is running. In *testing* mode, holding the *Formula B* button depressed makes *input B* to the microprocessor.

| Display or Action | Explanation |
|---------------------------------------|--|
| ABCDEFGH Output # -+----- 00 is On | Typical display in <i>testing</i> mode with button ⓑ held depressed. |

- 3.2.2.1.3. **Formula C button (C)**—With the display kit attached and the machine in *normal operation* mode (DIP switch position 8 is *on*), this button cycles the display through its four modes: *DIP switch settings*, *timer display*, *inputs display*, and *outputs display*. Each display is fully described in Section 4.1. “Troubleshooting Errors”.

In *testing* mode, holding the *Formula C* button depressed makes *input C* to the microprocessor.

| Display or Action | Explanation |
|--|---|
| <pre> ABCDEFGHIH Output # ---+----- 00 is On </pre> | Typical display in <i>testing</i> mode with button C held depressed. |

- 3.2.2.1.4. **Formula D button (D)**—This button is ignored if the machine is in *normal operation* mode and a formula is running. In *testing* mode, holding the *Formula D* button depressed makes *input D* to the microprocessor.

| Display or Action | Explanation |
|--|---|
| <pre> ABCDEFGHIH Output # ---+----- 00 is On </pre> | Typical display in <i>testing</i> mode with button D held depressed. |

- 3.2.2.2. **Terminate Button**—In *normal operation* mode, this button terminates the formula in progress. All controls are immediately locked out for a safety delay of 75 seconds.

In *testing* mode, the *Terminate* button provides *input F* to the microprocessor.

- 3.2.2.3. **Last Rinse Light**—During normal operation the *Last Rinse* light illuminates constantly from the beginning of the last bath step (last rinse) until the formula ends, 75 seconds after the end of the final extract step.

In *testing* mode, the *Last Rinse* light illuminates when *output 8* is *on*.

- 3.2.2.4. **In Progress Light**—In normal operation with the display attached, this light is illuminated when *output j* is present.

| Display or Action | Explanation |
|---|--|
| <pre> abcdefghijklmnop ---+-----+----- </pre> | Typical display during normal operation with the drain closed (<i>output c</i>), the basket turning clockwise (<i>output f</i>), and the <i>In Progress</i> light illuminated (<i>output j</i>). |

In *testing* mode, the *In Progress* light illuminates when *output 9* is *on*.

- 3.2.2.5. **Door Unlock Button**—In normal operation with the display attached, this button is enabled 75 seconds after a formula ends for any reason. The door cannot be unlocked until the 75-second safety delay expires. The safety delay also applies for 75 seconds after power is first applied to the machine.

In *testing* mode, the *Door Unlock* button is energized only when *output 00* is *on*. With *output 00 on*, you should hear the door unlock when this button is pressed.

— End of BICEUF01 —

3.3. E-P OneTouch[®] Operation

3.3.1. Instructions for Normal Operation

3.3.1.1. Load the Machine

1. If the loading door is closed and latched, hold the *Door Unlock* button (Ⓢ) to unlock the door while turning the door latch handle with the other hand. If the door does not unlock, verify that the machine is connected to power and that the wall disconnect is functioning properly. The machine must have power available to unlock the door.
2. When the door opens, load the machine according to plant guidelines and [Section 3.1. “Determining Load Size”](#).
3. Close the door firmly.

3.3.1.2. Start a Formula

- 3.3.1.2.1. **After a Completed Formula (Normal)**—If the previous formula finished normally, simply press the button that matches the formula you want to run. The selected formula will start immediately if the door is closed. The *Formula Running* light (1) illuminates and the door locks immediately, and the machine fills with water. Once the door is locked, the operator must end the formula early (see [Section 3.3.2](#)) or wait for the formula to finish before opening the door.
- 3.3.1.2.2. **After Opening the Door during a Formula**—If you ended the previous formula early by opening the door, you must press the *Terminate* button (Ⓣ) before you can start the machine again. The *Terminate* button also clears any internal machine error that might have caused the formula to end early.
- 3.3.1.3. **Unload the Machine**—When the formula ends, the *Formula Running* light (1) goes out. Hold the *Door Unlock* button (Ⓢ) to unlock the door while turning the door latch handle with the other hand.

3.3.2. How to End a Formula Early

You can end any running formula by pressing the *Terminate* button (Ⓣ) on the control panel. A safety delay keeps the door locked for 75 seconds. When the *In Progress* light goes off, hold the *Door Unlock* button (Ⓢ) to unlock the door while turning the door latch handle with the other hand.

To resume operation, restart the formula from the beginning by pressing the desired *formula button*.

— End of BICEU001 —

Chapter 4

Testing and Troubleshooting

BICEUT03 (Published) Book specs- Dates: 20130909 / 20130909 / 20130909 Lang: ENG01 Applic: CEP

4.1. Troubleshooting Errors

4.1.1. Vibration Switch Tripped

If the machine vibrates excessively during extract, the vibration switch (SMWVB in the electrical schematics) closes to ground an input (MTA3-10) to the microprocessor. When the machine is in an extract step and this input is grounded, the controller immediately ends the extract step and starts the subsequent coast step. The formula then continues normally.

Note 5: The input which indicates that the vibration switch is tripped is shared with the high water level pressure switch. Software determines whether to turn off the water valve(s) or to signal the inverter to stop the motor depending on the operation running when the input is grounded.

4.1.2. Door Open

When the machine operates normally, relay-contacts 5 and 8 in relay CRDL close and make the input on MTA3-5 to the microprocessor. If the door opens, the input stops. When the input stops, the microprocessor stops the machine. For safety, the machine ignores all controls for 75 seconds after the error.

When this error occurs, the microprocessor flashes the *In Progress* light and the *Last Rinse* light at the same time. Both lights flash *on* for 2 seconds, then *off* for 2 seconds, repeating for 10 minutes. After 10 minutes, both lights stay off.

Push the *Terminate* button () to recover from this error, ensure that the door is securely closed, then start the formula again.

4.1.3. High Level Still Made

The machine will not increase the speed from drain speed to extract speed if the high-level input (MTA3-8) is grounded. This input grounds when the high-level switch is closed. If the controller sees the high-level input when extract speed starts, the machine will ignore the extract step and decrease the speed without power.

Look for a blocked pressure hose to the level switch or a broken level switch.

4.1.4. Door/Inverter Fault

This error indicates one of three conditions: the operator selected a formula before closing the door, the door opened while the machine was operating, or the inverter sensed a fault during operation.

4.1.4.1. Fault Occurs before a Formula Starts—Normal operation requires the operator to close the door before selecting a formula to run. If the operator pushes one of the four *Formula Selection* buttons while the door is open, the controller recognizes an error condition.

1. The controller prevents further operation for a safety delay period of 100 seconds.
2. If the operator closes the door, the *In Progress* light and the *Last Rinse* light flash simultaneously.
3. After the safety delay period, the lights continue flashing until the operator pushes the *Terminate* button (⏏) to clear the error.
4. The lights stop blinking after 10 minutes unless the operator clears the error, but the error is cleared only when the operator pushes the *Terminate* button.

4.1.4.2. Fault Occurs During Operation—When operating normally, the inverter closes an internal contact wired in series with CRDL pins 5 and 8. If the door is closed and the inverter is functioning, the input on MTA3-5 is grounded, as described in [Section 4.1.2](#). If the inverter senses a fault, its internal contacts open and the input on MTA3-5 is lost. This same input is also lost if the door opens during operation. Refer to the inverter documentation for specific troubleshooting procedures.

As happens when the door opens during a formula, the microprocessor signals the error by flashing both the *In Progress* light and the *Last Rinse* light simultaneously. Both lights flash *on* for two seconds, then *off* for two seconds, repeating for 10 minutes. After 10 minutes, both lights remain off.

For safety, all machine controls are disabled for 100 seconds after the error occurs. To open the door after this error, you must first wait the 100 seconds until the controls are enabled. Then push the *Terminate* button (⏏) to clear the error condition. Finally, hold the *Door Unlock* button (Ⓜ) turn the door latch handle.

After correcting any error with the inverter itself, start the formula again.

— End of BICEUT03 —

BICEPT02 (Published) Book specs- Dates: 20130909 / 20130909 / 20130909 Lang: ENG01 Applic: CEP

4.2. Testing MWR_ Washer-extractors

4.2.1. Testing without the Display Kit

Most functions of this machine can be tested with an accurate digital voltmeter if the schematic diagrams are available and you have a thorough understanding of how the machine normally operates.

The following rules will help you determine the current machine event.

Chart 1: Operating Sequence Part 1

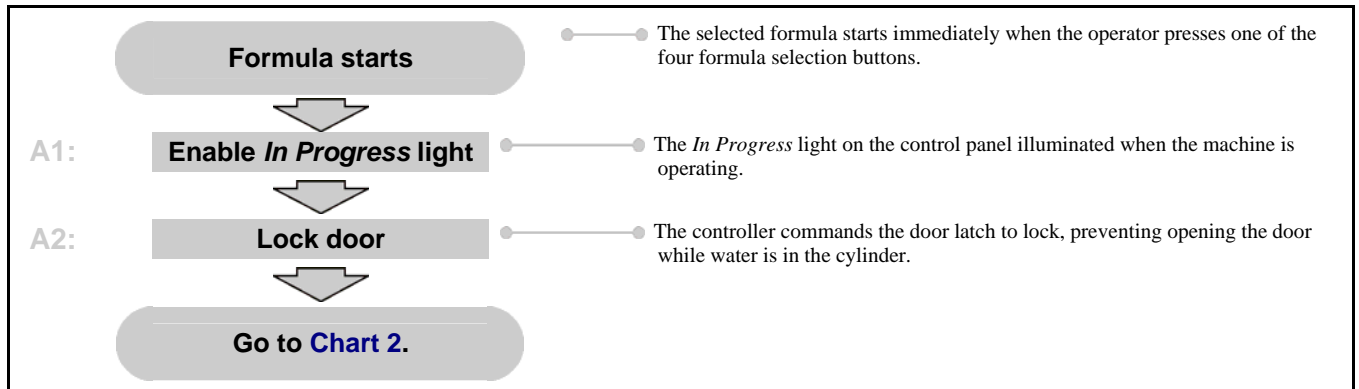

Chart 2: Operating Sequence Part 2

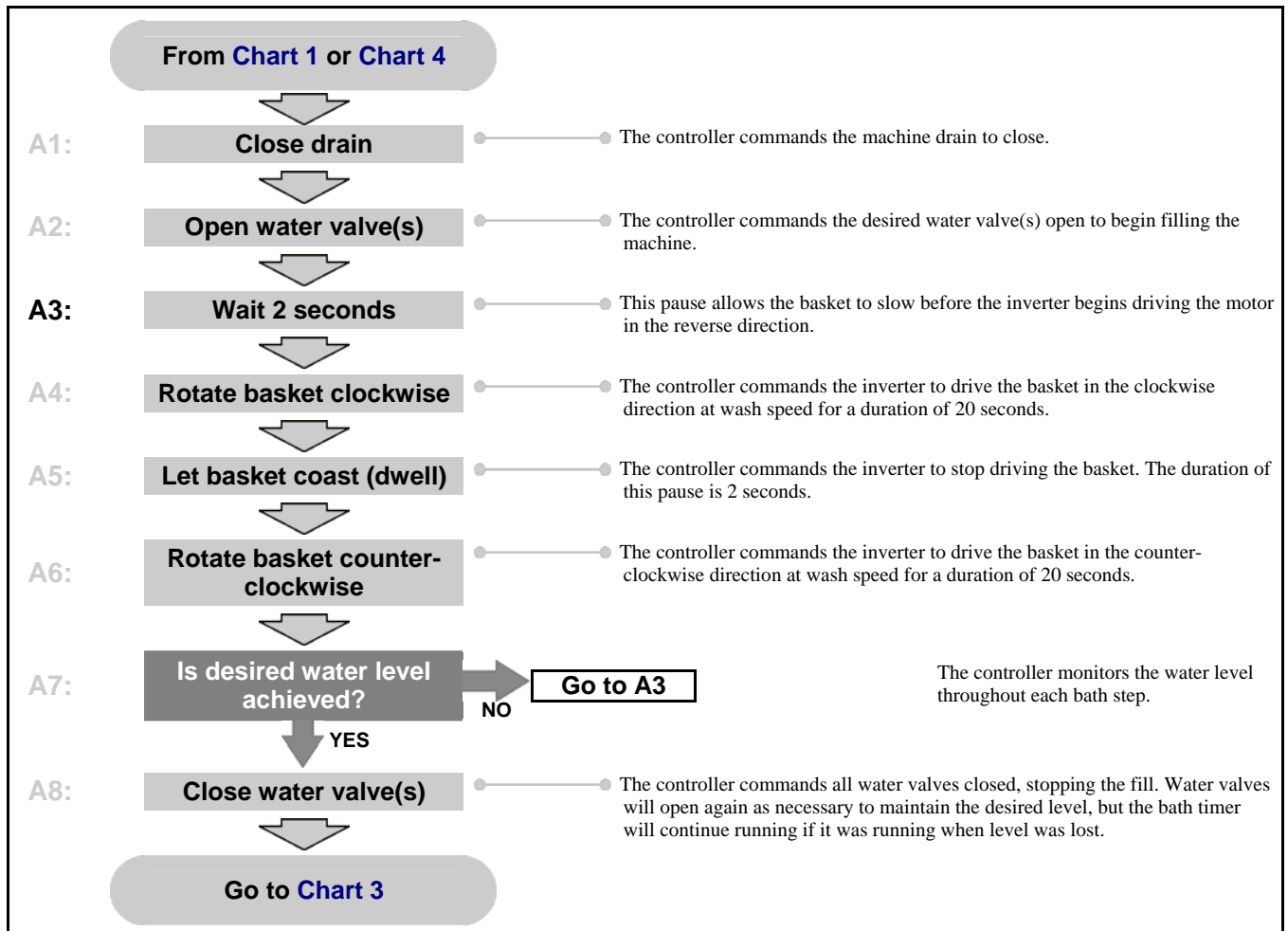

Chart 3: Operating Sequence Part 3

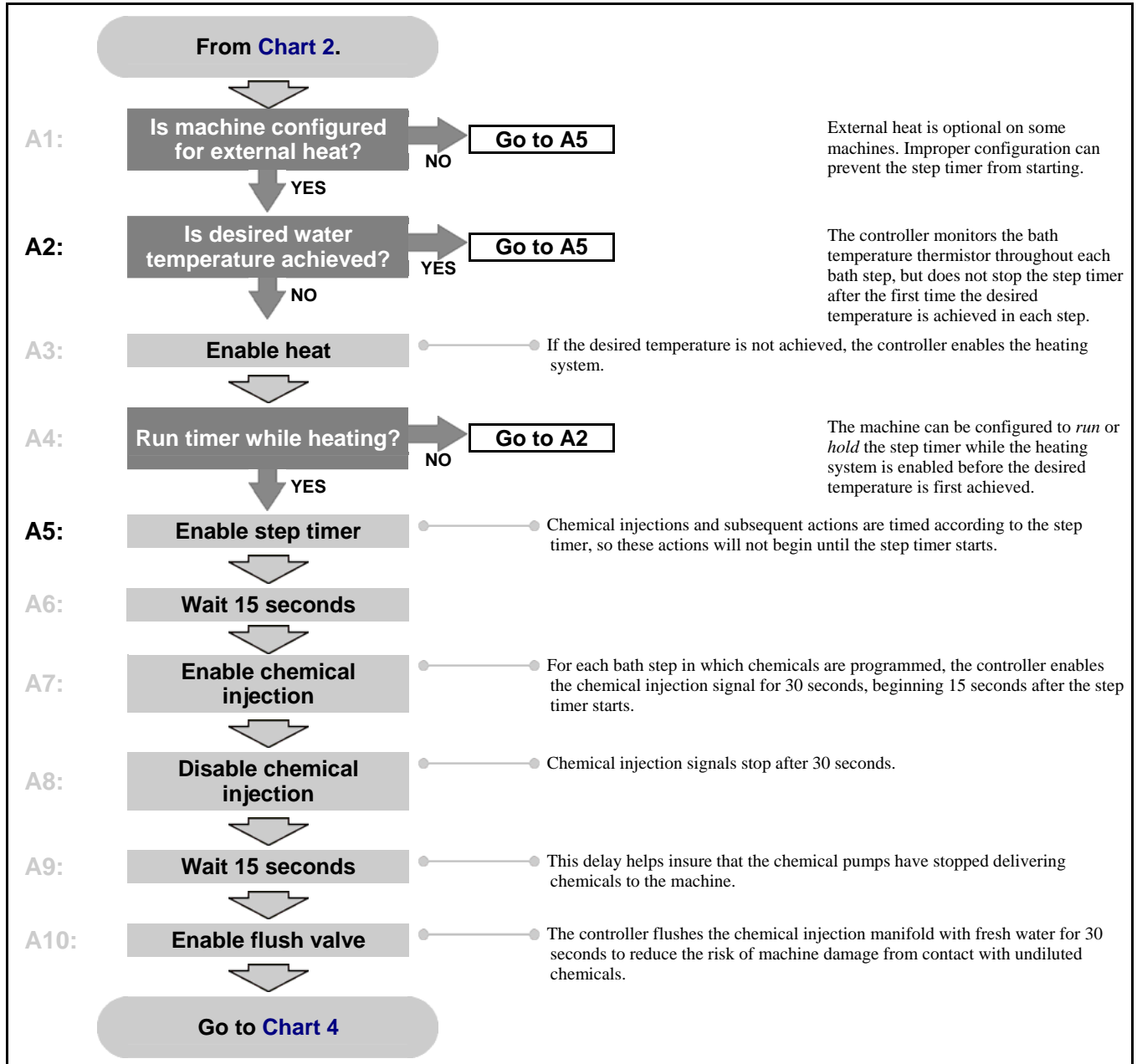
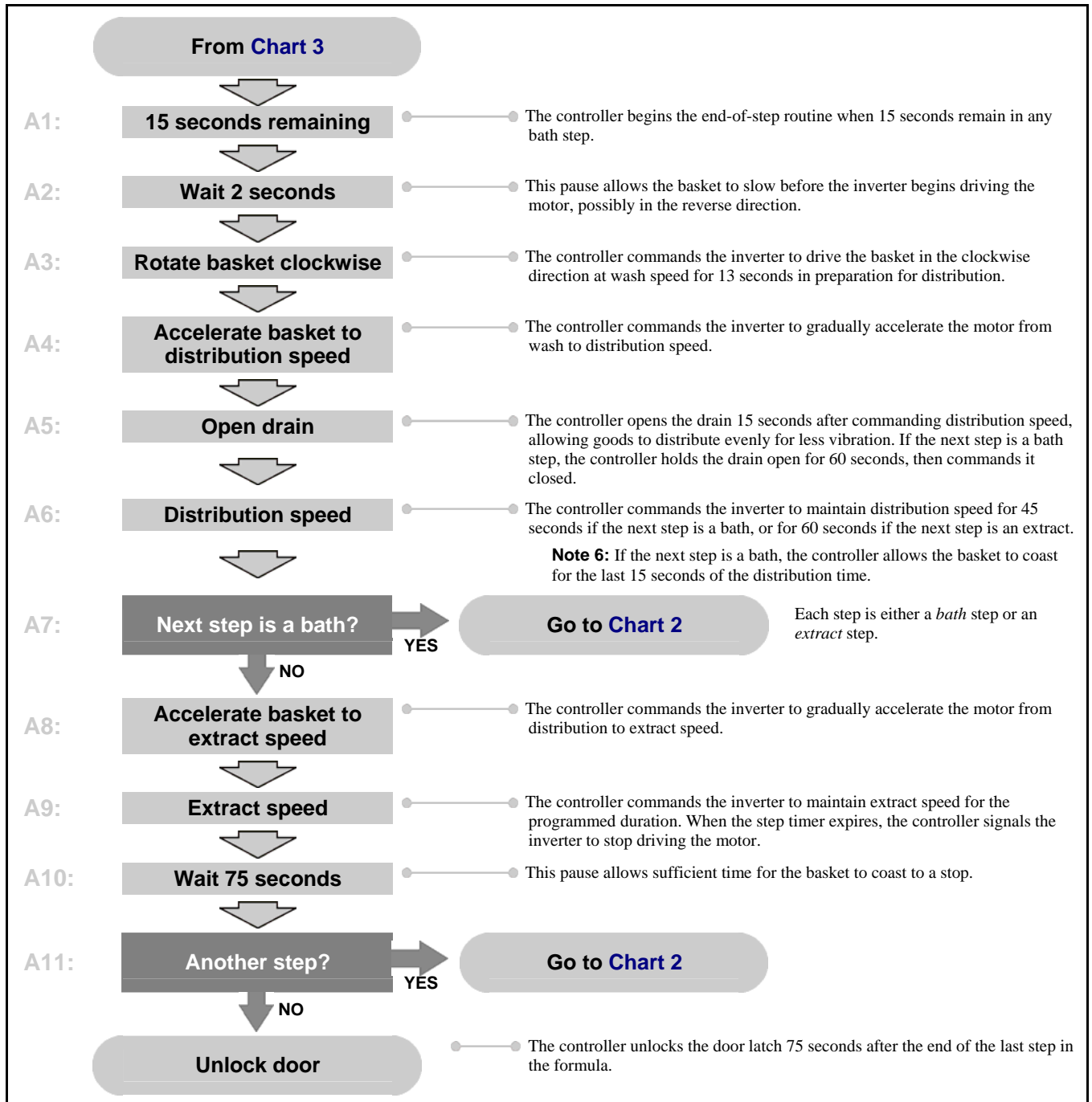

Chart 4: Operating Sequence Part 4



4.2.2. Testing with the Display Kit

A kit consisting primarily of a vacuum fluorescent display and a wiring harness to connect the display to the microprocessor controller is available from the Milnor[®] factory. Contact the Milnor[®] parts department for details.



CAUTION [11]: Avoid machine damage—Because of the additional power required to operate the display, some components of the microprocessor controller may be damaged if the display is connected for extended periods of time.

- Connect the display only when testing the machine.
- Disconnect the display and replace all control panel covers before returning the machine to normal operation.

4.2.2.1. Connecting the Display

1. *Lock off/tag out* power to the machine.
2. Remove the cabinet top and rear panels to gain access to the microprocessor controller. When viewed from the rear of the machine, the controller is mounted to your left. Don't try to connect the display to the large white Magnetek component (motor inverter) to your right.
3. Connect the flat black connector on the display cable to MTA2 on the controller. Use [Figure 8](#) as a reference to properly orient the connector to the pins on the controller. The four wires in the connector should be on the side nearest MTA3, and the two connector sockets without wires are nearest the long side of the board.



CAUTION 12: **Avoid personal injury and machine damage**—Because the machine must have power available for testing, use extreme caution when working in the area of high voltage and moving mechanical parts.

- Lock off/tag out power before reaching into the machine.
- Route the display wiring clear of the motor and pulleys.

Figure 8: Processor Boards

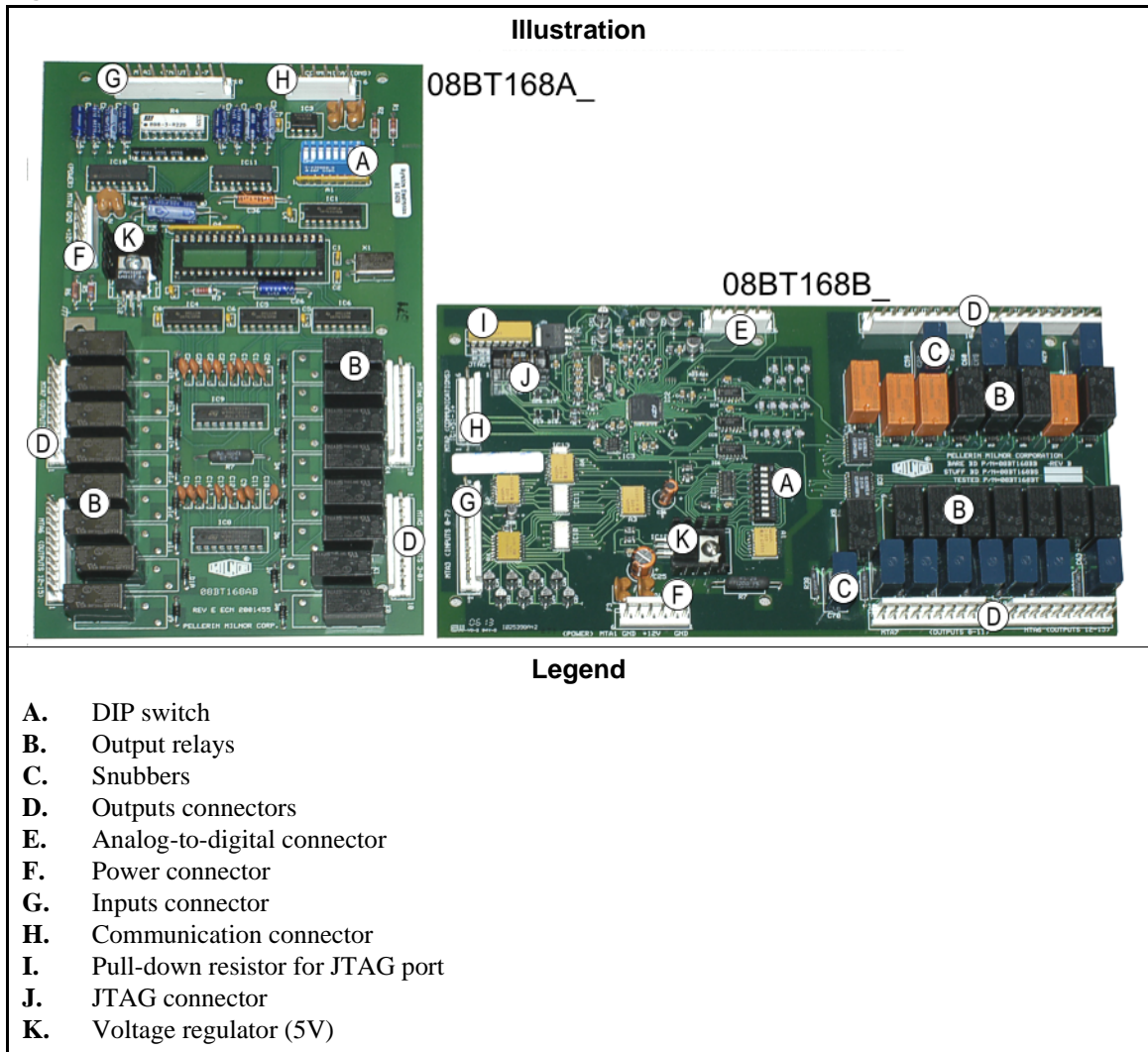

4.2.2.2. Displays in Run Mode—With the display connected and power to the machine, you can select from five display modes without changing the DIP switch settings: *timer*, *DIP switches*, *inputs*, *outputs*, and *analog-to-digital channels*. The *timer display* shows certain general information about the current formula, as explained in [Section 4.2.2.2.1](#). The *DIP switches display* shows the on/off status of each DIP switch position. The *inputs display* ([Section 4.2.2.2.3](#)) shows the on/off status of each of the eight inputs. The *outputs display*, described in [Section 4.2.2.2.4](#), shows the on/off status of the 16 outputs. The *analog-to-digital channel display* is detailed in [Section 4.2.2.2.5](#).

Chart 5: Overview of Run Mode Diagnostics

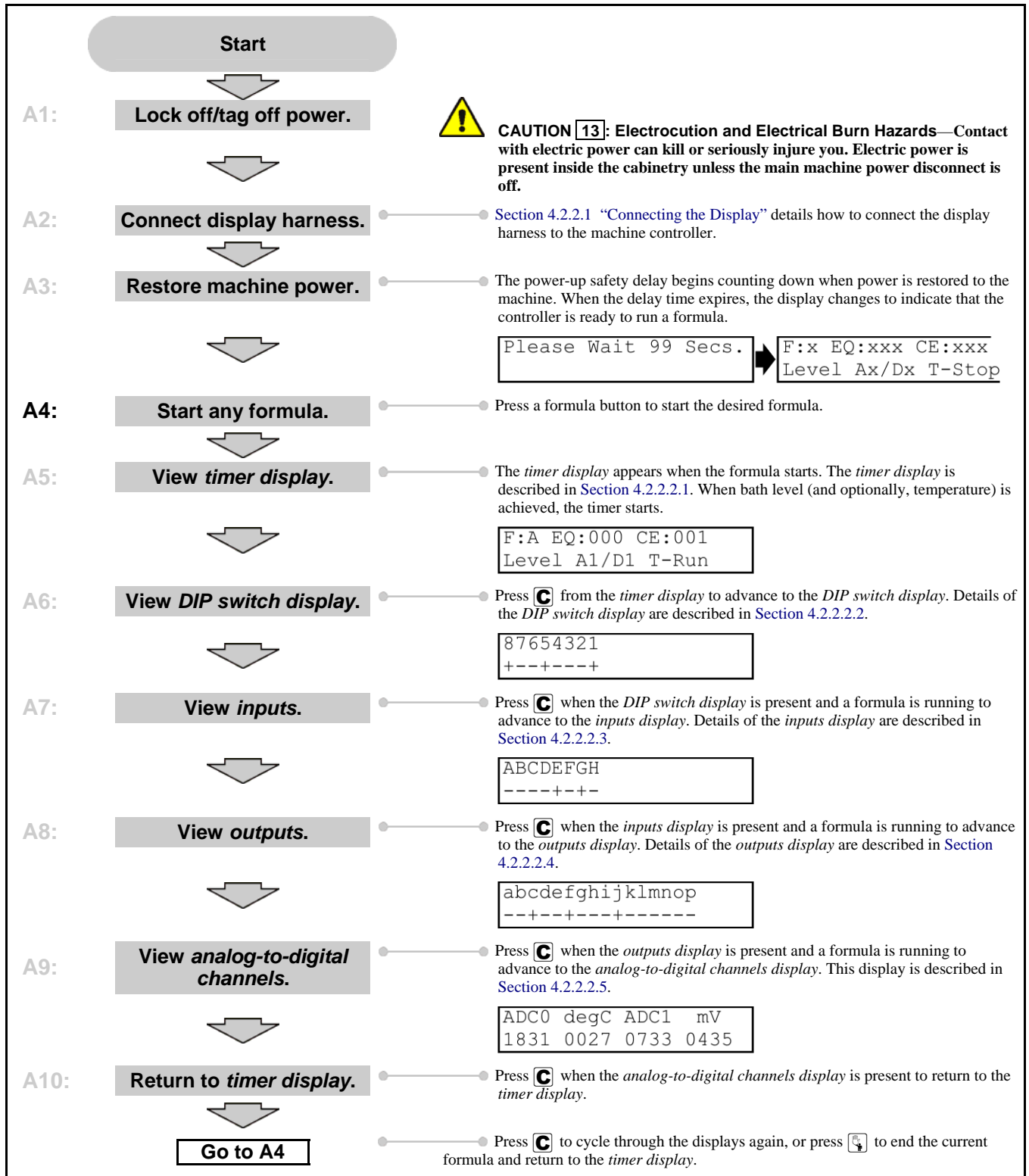

4.2.2.2.1. **Timer Display**—When power is supplied to the machine, the display shows the time remaining in the power-up safety delay and the *In Progress* light flashes. When you start a formula, the

display shows certain information about machine operation as it occurs.

| Display or Action | Explanation |
|---|--|
| Please Wait 99 Secs. . | Typical power-up display immediately after applying power to the machine. The <i>In Progress</i> light (T) flashes during the delay. |
| F:x EQ:xxx CE:xxx Level Ax/Dx T-Stop | Typical display when the machine is ready to run, but before starting a formula. |

F:x—Selected formula, if any. The “x” this field is replaced by A, B, C, or D, when a formula is running.

EQ:xxx—Elapsed quarters. This field shows how many quarter-minute (15-second) periods have expired since the timer began running.

Note 7: Because the timer doesn't start running until the desired level is achieved, this field will not change from 000 to 001 until 15 seconds after level is achieved.

CE:xxx—Current event. Each of the four available wash formulas is made up of a series of events. These events are numbered upward continuously through all formulas, so formula A contains events 0 through 9, formula B is events 10 through 23, etc.

Level Ax/Dx—Level achieved and desired. Low level is represented by “1,” and high level is represented by “2.” Achieved level is the number after “A,” and desired level is the number after “D.” For example, “A0/D2” indicates that level 2 is desired, but the actual level is still below low level. “A2/D2” indicates that level 2 is desired and achieved.

T-xxxx—Timer status. “T-Run” indicates that the timer is running, while “T-Stop” indicates that the timer is stopped. The timer is stopped while the machine is filling and when the *timer stop* input is present.

- 4.2.2.2.2. **DIP Switch Display**—From the timer display with a formula running, press the *Formula C* button once to view the on/off status of the eight positions of the DIP switch. On this display only, “+” indicates that the switch position is off and “-” indicates that the switch position is on.

| Display or Action | Explanation |
|---|--|
| F:C EQ:026 CE:024 Level A1/D1 T-Run | This is a typical timer display. |
|  | Scrolls from the timer display to the DIP switch display. |
| 87654321 -+-+--++ | This example of the DIP switch display shows that positions 8, 5, and 3 are <i>on</i> , and the other positions are <i>off</i> . See Section 2.1.2 “Configuration Decisions for Machines with Controller 08BT168AT or 98CMCR0911” for the application of each switch position. |

- 4.2.2.2.3. **Inputs Display**—From the DIP switch display with a formula running, press the *Formula C* button once to view the on/off status of the eight controller inputs.

Display or Action

```

ABCEFGH
-----+-+
    
```

Explanation

This is a typical input status display during a bath with a chemical. See [Table 13](#) for the input that corresponds to each character on the display. A plus sign (+) appears below each active input; a minus sign (-) appears below each input that is not present. In the example display to the left, inputs E and G are present, indicating that the door is closed and low level is achieved.

Table 13: E-P OneTouch Inputs

| Display Letter | Input Description | Connector and Pin | Notes |
|----------------|---|-------------------|--|
| A | Formula A button depressed or timer stop commanded | MTA3-1 | Timer stops while button is depressed. |
| B | Formula B button depressed | MTA3-2 | |
| C | Formula C button depressed | MTA3-3 | Can't be tested, but can be assumed functional if you can view the inputs display. |
| D | Formula D button depressed | MTA3-4 | |
| E | Door is closed and inverter functioning | MTA3-5 | Input is lost when door opens or inverter faults during a formula. |
| F | Terminate button is depressed or door open desired | MTA3-6 | Testing terminates current formula. |
| G | Low level achieved | MTA3-7 | |
| H | High level achieved or vibration safety switch closed | MTA3-8 | Water valves close or controller terminates extract step. |

4.2.2.2.4. **Outputs Display**—From the inputs display, press the *Formula C* button once to view the on/off status of the 16 controller outputs.

Display or Action

```

ABCEFGH
-----+
    
```

Explanation

This is a typical *input status* display during a flush or rinse bath.



Scrolls from the *inputs* display to the *outputs* display.

```

abcdefghijklmnop
-----+-----
    
```

This is a typical output status display during a bath with a chemical. See [Table 14](#) for the output that corresponds to each character on the display. A plus sign (+) appears below each active output; a minus sign (-) appears below each output that is not energized. In the example display to the left, outputs c, f, and j are present, indicating that the drain is closed, the motor is energized in the clockwise direction, and the *Formula Running* light is lit.

Table 14: E-P OneTouch Outputs

| Display Letter | Output Number | Output Description | Connector and Pins | Notes |
|----------------|---------------|--|--------------------|---|
| a | K0 | Enable Door Unlock button | MTA5 pins 9 and 10 | |
| b | K1 | Signal inverter for drain speed | MTA5 pins 7 and 8 | |
| c | K2 | Close drain | MTA5 pins 3 and 4 | |
| d | K3 | Open hot water valve | MTA5 pins 1 and 2 | |
| e | K4 | Open cold water valve | MTA4 pins 9 and 10 | |
| f | K5 | Signal inverter for clockwise wash | MTA4 pins 7 and 8 | |
| g | K6 | Signal inverter for counter-clockwise wash | MTA4 pins 3 and 4 | |
| h | K7 | Signal inverter for extract speed | MTA4 pins 1 and 2 | |
| i | K8 | Turn on Last Rinse light | MTA7 pins 9 and 10 | light illuminates when last bath step begins; flashes to signal error |
| j | K9 | Turn on In Progress light | MTA7 pins 7 and 8 | light is on throughout formula; flashes to signal error |
| k | K10 | In Progress Slave (08BT168AB) or External Heat (08BT168BB) | MTA7 pins 3 and 4 | actuates when optional external heat is desired |
| l | K11 | Door Lock | MTA7 pins 1 and 2 | |
| m | K12 | Flush chemical manifold | MTA6 pins 9 and 10 | |
| n | K13 | Inject soap | MTA6 pins 7 and 8 | |
| o | K14 | Inject bleach | MTA6 pins 3 and 4 | |
| p | K15 | Inject sour/softener | MTA6 pins 1 and 2 | |

4.2.2.2.5. Analog-to-Digital Channels Display

Notice 14: Analog-to-digital information applies to machines with board 08BT168B_ only.

From the inputs display, press the *Formula C* button once to view the values of the two analog-to-digital channels. The temperature probe is connected to channel 0, and channel 1 is not used.

The electrical resistance of the thermistor temperature probe decreases as the temperature sensed by the probe increases (inverse relationship). The probe connects to the controller board at MTA8. Components on the controller board convert the analog signal from the temperature probe to a digital value. The temperature of the probe is calculated from this digital value.

Display or Action

| | | | |
|------|------|------|------|
| ADC0 | degC | ADC1 | mV |
| 1831 | 0027 | 0733 | 0435 |

Explanation

This is a typical display of the analog channels with the temperature probe at room temperature. The top line of the display contains the field names, and the bottom line contains the value of the field.

Display or Action

| |
|------|
| ADC0 |
| 1831 |

Explanation

This display shows a value of 1831 for analog-to-digital channel 0. The analog-to-digital components of the controller convert the analog output from the temperature probe to a digital raw counts value. The controller software reads this raw counts value and converts it to a Celsius temperature.

| |
|------|
| degC |
| 0027 |

The temperature shown here is derived from the displayed raw counts value. This is the current temperature sensed by the temperature probe, in Celsius degrees.

| |
|------|
| ADC1 |
| 0733 |

This display shows a value of 0733 for analog-to-digital channel 1. This channel is not used, but is available for future applications.

| |
|------|
| mV |
| 0435 |

This is the millivolts reading derived from the analog-to-digital value of channel 1. This value is not used.

4.2.2.3. Displays in Test Mode—Observing the action of inputs and outputs during normal operation is an important part of troubleshooting the machine. However, testing for a specific problem can often be done more efficiently by actuating specific outputs and grounding inputs individually. The test mode provides a display for viewing input and output status, and for actuating outputs.

4.2.2.3.1. Setting the DIP Switch for Test Mode

1. Lock off/tag off power to the machine.
2. Remove the cabinet top and rear panels to access the microprocessor controller.
3. Using the instructions in [Section 2.1. “Configuring E-P OneTouch® Washer-extractor Models”](#), turn *off* position 8 of DIP switch SW1. See [Figure 9](#).

Figure 9: Test Mode Selected

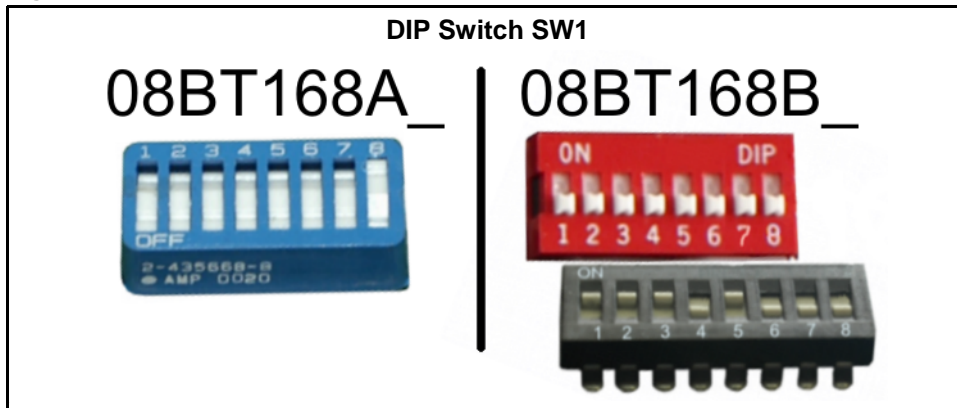

4. Apply power to the machine. The display will appear similar to this:

Display or Action

| | |
|----------|----------|
| ABCDEFGH | Output # |
| ----- | 00 is On |

Explanation

Normally, inputs A through H will be *off* (noted by a minus sign [-] below the letter) except perhaps input E. Input E will normally be *on* (noted by a plus sign [+] below the letter) if the machine door is closed. Output 00 is *on*, indicating that the *Door Unlock* button (Ⓢ) is enabled.

4.2.2.3.2. Interpreting the Display

Display or Action

| | |
|----------|----------|
| ABCDEFGH | Output # |
| ----+--- | 00 is On |

Explanation

This is the normal testing display as it appears at power-up with the door closed. The eight inputs appear on the left of the display, and each output appears on the right side as it is actuated. This display shows that input E is enabled, indicating that the door is closed.

4.2.2.3.3. **DIP Switch Display**—From the normal testing display, press **C** one time to view the on/off status of each of the DIP switch positions.

Display or Action

| |
|----------|
| 87654321 |
| +---+--- |

Explanation

The switch positions appear on the top line of the display. A plus sign (+) directly under a switch position indicates that the position is off, while a minus sign (-) indicates that the position is on.

4.2.2.3.4. **Viewing Inputs**—Two types of tests can be performed while observing the status of the inputs:

- testing the switch or other auxiliary component that provides the input to the controller, and
- testing the controller and how it behaves when certain inputs are present.

4.2.2.3.4.1. **Testing Auxiliary Components**—The E-P OneTouch® controller has eight inputs into the controller, six of which can be actuated from the control panel on the front of the machine. The two level switch inputs require grounding terminals on the level switch.



CAUTION 15: Avoid personal injury—When input A is grounded, the machine automatically closes and opens each of the 16 outputs in sequence. This arrangement prevents the motor from turning the cylinder at drain or extract speed, but allows the cylinder to turn at wash

speed in either direction if the door is closed.

- Never attempt to defeat the safety mechanisms to test cylinder rotation with the door open.

Formula A and timer stop (Input A)—This input is grounded (changes from – to +) when **A** is pressed, indicating that the keypad button is working and the processor is correctly interpreting the signal. If the *timer stop* feature of this machine is used (usually by the chemical supply system), grounding this input while the machine is running a formula causes the timer to stop counting until the input is released.



CAUTION 16: Entanglement hazard—Because the *Formula A* button (**A**) also tests the machine outputs, the motor may start and the cylinder may turn when this button is pressed.

- Ensure that no one is near the motor or drive pulley during testing.

Formula B (Input B)—This input is grounded when **B** is pressed, indicating that the keypad button is working and the processor is correctly interpreting the signal.

Formula C (Input C)—This input is grounded when **C** is pressed, indicating that the keypad button is working and the processor is correctly interpreting the signal.

Formula D (Input D)—This input is grounded when **D** is pressed, indicating that the keypad button is working and the processor is correctly interpreting the signal.

Door Closed and inverter functioning (Input E)—This input is grounded when the processor sees the that door is securely closed and the inverter is functioning properly. The machine will not run if this input is not grounded (+).

Terminate button (Input F)—This input is grounded when the *Terminate* button (**F**) is pressed.

Low level achieved (Input G)—This input is grounded when the pressure switch for low level (SPLL on the schematic) is closed. This can be simulated by briefly touching a length of wire between the power and ground terminals (see [Figure 10](#)) on the level switch. Do not remove the wires from these terminals for this test.

High level achieved or vibration safety switch tripped (Input H)—This input is grounded when the pressure switch for high level (SPHL on the schematic) is closed. This can be simulated by briefly touching a length of wire between the power and ground terminals (see [Figure 10](#)) on the level switch. Do not remove the wires from these terminals for this test. This input is also made when the vibration safety switch trips. The vibration safety switch can be tested by gently holding the pendulum to one side and watching for the input status to change.

Note 8: High level pressure switch SPHL has two wires attached to one of the terminals and one wire attached to the other terminal. Low level pressure switch SPLL has only one wire attached to each terminal.

Figure 10: Level Switch Testing

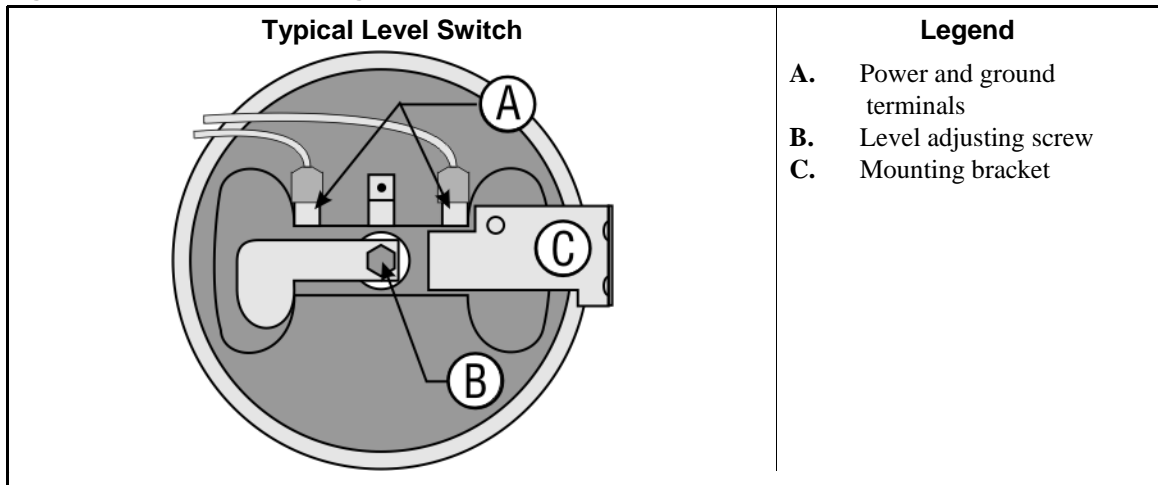

4.2.2.3.4.2. **Testing the Controller**—The input testing procedures described in [Section 4.2.2.3.4.1](#) verify that the microprocessor controller is receiving a signal from an external component, processing the signal, and writing the results to the display. Further testing is required if a component is actuated as described above, but the display does not indicate that it's actuated. By using the information in [Section 4.2.2.3.4.2](#) and the schematic manual, a qualified technician can determine whether the problem lies with the component or the microprocessor controller.

4.2.2.3.5. **Testing Outputs**—The E-P OneTouch[®] controller operates the chemical system and all other devices in the machine by turning output relays on and off according to specific instructions. For example, output relay K2 is dedicated to the machine drain. When this relay is energized, it closes a circuit between pins 3 and 4 on MTA5 to provide power to the drain valve. Because a spring in the drain valve opens the drain valve when power is not present, the drain is closed only while output K2 is closed.

While all output relays can only be open or closed, two types of results can be achieved from any output, depending on how it is used in the machine:

Direct outputs—These outputs, such as the *drain output* relay (K2) and the *last rinse output* relay (K8), act as a switch in the circuit for the device to which they are assigned. Output K2 is described above. Output K8 closes when the last bath step of a formula begins, providing power to the *Last Rinse* light on the control panel.

Indirect (signal) outputs—Indirect outputs signal other devices to operate. The most important of these are the outputs that control how the motor inverter powers the motor to turn the basket. When output K5 is closed, the inverter powers the motor to turn clockwise at wash speed. Output K6 causes the inverter to run the motor counterclockwise, but still at wash speed. When outputs K5 and K7 are on (contacts closed) at the same time, the basket runs clockwise at extract speed. The chemical outputs (K13, K14, and K15) signal the chemical supply system to provide chemical to the machine. Output K12 signals to flush the chemical injection manifold.



CAUTION 17: Avoid machine damage—This controller is designed to allow the **momentary** actuation of outputs to verify proper operation. Continuous manual operation of outputs may cause machine damage, especially if chemicals are actuated and not flushed completely from the machine after testing.

- If chemicals are connected to the machine when outputs are tested, always activate the flush output to dilute and flush out any chemical in the manifold and the machine.

Display or Action

Explanation



Press and release this button to turn off the current output and select and actuate the next one. For example, if the display says, “Output #3 is On,” press **A** one time and release it to turn off output 3 and turn on output 4. The display then shows, “Output #4 is On.”

Hold this button depressed to automatically cycle through all 16 outputs. As described above, only one output is actuated at any time. The display will turn each output on for approximately one half second, then advance to the next output in numerical order.

The goal in testing outputs is to verify that the specified device operates when the controller commands it to operate. Some devices, such as water valves and chemical injections, cause a result that can be seen or heard (water or chemical entering the machine). Others, especially drain and extract speed commands, can only be verified with the proper use of a voltmeter. Use the information below and the electrical diagrams for this machine to test a component.

Door Unlock button (Output 00)—When this output is enabled, it remains enabled for two seconds before it turns *off*. While enabled, this relay enables relay CRD to lock the door. The *Door Unlock* button () must be held depressed while testing this output or it will not energize.

Drain Speed inverter signal (Output 01)—This output signals the inverter to run the motor at drain speed. However, both the clockwise wash signal and the drain speed signal must be present for the basket to turn. Test this output relay (K01) by checking for a signal of 24 volts DC between pins 7 and 8 of MTA5 when the relay should be off, dropping to 0 volts when the relay should be on.

Drain Closed (Output 02)—This output relay closes to energize the normally-open drain valve, causing it to close. Test relay K02 by observing the drain valve under the machine or by checking for control voltage between fuse EF71B and pin 3 of MTA5 when the relay should be closed (drain closed), dropping to 0 volts when the relay should be open (drain open).

Hot Water Valve On (Output 03)—This output relay closes to energize the normally-closed hot water valve, causing it to open. A voltmeter should indicate control circuit voltage between fuse EF71B and pin 1 of MTA5 when the valve is open and hot water is flowing into the machine, dropping to 0 when the valve is closed.

Cold Water Valve On (Output 04)—This output relay closes to energize the normally-closed cold water valve, causing it to open. A voltmeter should indicate control circuit voltage between fuse EF71B and pin 9 of MTA4 when the valve is open and cold water is flowing into the machine, dropping to 0 when the valve is closed.



CAUTION 18: Entanglement hazard—The machine basket rotates when output 05 or 06 is actuated.

- Keep all personnel clear of the motor and drive components when testing these outputs.

Clockwise Wash Speed inverter signal (Output 05)—This output signals the inverter to run the motor clockwise at wash speed. Test this output relay (K05) by checking for a signal of 24 volts DC between pins 7 and 8 of MTA4 when the relay should be *off*, dropping to 0 volts when the relay should be *on*.

Counter-clockwise Wash Speed inverter signal (Output 06)—This output signals the inverter to run the motor counter-clockwise at wash speed. Test this output relay (K06) by checking for a signal of 24 volts DC between pins 3 and 4 of MTA4 when the relay should be *off*, dropping to 0 volts when the relay should be *on*.

Extract Speed inverter signal (Output 07)—This output signals the inverter to run the motor at extract speed. However, both the clockwise wash signal and the extract speed signal must be present for the basket to turn. Test this output relay (K07) by checking for a signal of 24 volts DC between pins 1 and 2 of MTA4 when the relay should be *off*, dropping to 0 volts when the relay should be *on*.

Last Rinse Light On (Output 08)—Output K08 closes to power the *Last Rinse* light on the control panel. When the output is *on*, a voltmeter will read the control circuit voltage between fuse EF71B and pin 10 of MTA7. When the output is turned *off*, the voltage drops to 0.

In Progress Light On (Output 09)—When output relay K09 is *on*, the *In Progress* light should be *on* and a voltmeter should read control circuit voltage between fuse EF71B and pin 8 of MTA7.

In Progress Light slave (Output 10 on controller board 08BT168A_ only)—This relay operates identically to output 09, but is usually used to verify that the machine is running a formula before allowing the chemical supply system to stop the machine timer.

External Heat On (Output 10 on controller board 08BT168B_ only)—This relay closes when the controller desires external heat to increase the bath temperature. The relay opens when the configured temperature is achieved, the bath step runs to completion, or an error terminates the wash formula.

Door Lock (Output 11)—When this output is actuated, it remains enabled for two seconds, then turns off. While enabled, this relay powers relay CRE to lock the door.

Flush Chemical Manifold (Output 12)—When this output is *on*, control voltage flows between fuse EF71B and pin 1 of MTA7. This signal tells the chemical supply system that the chemical injection is complete and the machine desires to flush the chemical injection manifold.

Inject Detergent (Output 13)—When this output is *on*, control voltage flows between fuse EF71B and pin 7 of MTA6. This signal tells the chemical supply system that the machine desires detergent.

Inject Bleach (Output 14)—When this output is *on*, control voltage flows between fuse EF71B and pin 3 of MTA6. This signal tells the chemical supply system that the machine desires bleach.

Inject Sour/softener (Output 15)—When this output is *on*, control voltage flows between fuse EF71B and pin 1 of MTA6. This signal tells the chemical supply system that the machine desires sour/softener or sour/starch.

Low Level Test (Output 16)—This test is designed primarily for calibrating low level pressure switch SPL. When this functional test is started, the drain closes and the cold water valve opens. The water valve closes when low level is achieved, indicated on the display by input G changing from a minus sign (–) to a plus sign (+).

Note 9: The door must be closed during this test.

High Level Test (Output 17)—This test is designed primarily for calibrating high level pressure switch SPHL. When this functional test is started, the drain closes if it was open and the cold water valve opens. The water valve closes when high level is achieved, indicated on the display by input H changing from a minus sign (–) to a plus sign (+).

Note 10: The door must be closed during this test.

Basket Speed Test (Output 18)—This test runs the cylinder at each of the three available speeds, as described below:

Note 11: The door must be closed during this test.

1. The drain opens and the cylinder begins turning clockwise at wash speed as soon as the technician enters this test. The basket continues turning at this speed until the technician presses **D** to test drain speed, or **A** to exit the speed test and return to *Output 00* (*Door unlock* button).
2. Pressing **D** with the cylinder at wash speed causes it to accelerate to drain speed. The basket continues turning at this speed until the technician presses **D** to test extract speed, or **A** to exit the speed test and return to *Output 00* (*Door unlock* button).
3. Pressing **D** with the cylinder at drain speed causes it to accelerate to extract speed. The basket continues turning at this speed until the technician presses **A** or the *Terminate* button (**⏏**) to exit the speed test and return to *Output 00* (*Door unlock* button). **If the command to accelerate to extract speed was entered, the basket coasts for 75 seconds with all controls disabled when the speed test is terminated.**

— End of BICEPT02 —