

Published Manual Number/ECN: MAUPLOPRAU/95093N

- Publishing System: TPAS
- Access date: 06/27/2000
- Document ECN's: Latest Available



**CE—**

**OPERATION - Mark II, Tilt-to-Unload Washer-Extractor**

**FONCTIONNEMENT- Mark II, Laveuse-essoreuse à renversement Avant**

**BETRIEB - Mark II, Kippbare Maschine (kippar bei Entladung)**

**WERKING - Mark II, Voorover kiepende Centrifugerende Wasmachine**

**FUNZIONAMENTO - Mark II, Lavacentrifuga Ribaltabile Per Scaricare**

# Please Read

## About the Manual Identifying Information on the Cover

The front cover displays pertinent identifying information for this manual. Most important, are the published manual number (part number) /ECN (date code). Generally, when a replacement manual is furnished, it will have the same published manual number, but the latest available ECN. This provides the user with the latest information applicable to his machine. Similarly all documents comprising the manual will be the latest available as of the date the manual was printed, **even though older ECN dates for those documents may be listed in the table of contents.**

When communicating with the Milnor factory regarding this manual, please also provide the other identifying information shown on the cover, including the publishing system, access date, and whether the document ECN's are the latest available or exact.

## References to Yellow Troubleshooting Pages

This manual may contain references to "yellow pages." Although the pages containing troubleshooting procedures are no longer printed on yellow paper, troubleshooting instructions, if any, will be contained in the easily located "Troubleshooting" chapter or section. See the table of contents.

## Trademarks of Pellerin Milnor Corporation

The following, some of which may be used in this manual, are trademarks of Pellerin Milnor Corporation:

Ampsaver <sup>®</sup>	CBW <sup>®</sup>	Gear Guardian <sup>®</sup>	Milnet <sup>®</sup>	Staph-Guard <sup>®</sup>
Autolint <sup>®</sup>	Dye-Extractor <sup>®</sup>	Hands-Off <sup>®</sup>	Milnor <sup>®</sup>	System 4 <sup>®</sup>
Auto-Purge <sup>®</sup>	Dyextractor <sup>®</sup>	Hydro-Cushion <sup>®</sup>	Miltrac	System 7 <sup>®</sup>
Autovac	E-P Plus <sup>®</sup>	Mildata <sup>®</sup>	Miltron	Totaltrol <sup>®</sup>

## Comments and Suggestions

Help us to improve this manual by sending your comments to:

Pellerin Milnor Corporation  
Attn: Technical Publications  
P. O. Box 400  
Kenner, LA 70063-0400

Fax: (504) 469-1849

**Table of Contents**  
**for MAUPLOPRAU/95093N**  
**OPERATION - Mark II, Tilt-to-Unload Washer-Extractor**

<b>Page</b>	<b>Description</b>	<b>Document/ECN</b>
<b>1</b>	<b>Section 1: English</b>	
2	Description of Controls - Mark II, Tilt-to-Unload Washer-Extractor	MSOUPLECTAE/9433AV
6	Normal Operation - Mark II, Tilt-to-Unload Washer-Extractor	MSOUPLNOAE/9433AV
12	Correcting Errors - Mark II Washer-Extractor	MSOUPUTSAE/9436AV
<b>17</b>	<b>Section 2: Français</b>	
18	Description des Commandes - Mark II, Laveuse-essoreuse à renversement Avant	MSOUPLECTAF/9433AV
22	Fonctionnement courant - Mark II, Laveuse-essoreuse à renversement Avant	MSOUPLNOAF/9433AV
28	Correction des Erreurs - Mark II Laveuse-essoreuse	MSOUPUTSAF/9436AV
<b>33</b>	<b>Section 3: Deutsch</b>	
34	Beschreibung der Steuerung - Mark II, Kippbare Maschine (kippar bei Entladung)	MSOUPLECTAG/9433AV
38	Normalbetrieb - Mark II, Kippbare Maschine (kippar bei Entladung)	MSOUPLNOAG/9433AV
44	Fehlerbehebung - Mark II, Wasch-Schleuder-Maschine	MSOUPUTSAG/9436AV
<b>49</b>	<b>Section 4: Nederlands</b>	
50	Beschrijving van de Besturing - Mark II, Voorover kiepende Centrifugerende Wasmachine	MSOUPLECTAH/9433AV
54	Normale werking - Mark II, Voorover kiepende Centrifugerende Wasmachine	MSOUPLNOAH/9433AV
60	Oplossen Storingen - Mark II Centrifugerende Wasmachine	MSOUPUTSAH/9436AV
<b>65</b>	<b>Section 5: Italiano</b>	
66	Descrizione dei Controlli - Mark II, Lavacentrifuga Ribaltabile Per Scaricare	MSOUPLECTAI/9433AV
70	Funzionamento Normale - Mark II, Lavacentrifuga Ribaltabile Per Scaricare	MSOUPLNOAI/9433AV
76	Correzione Errori - Mark II Lavacentrifuga	MSOUPUTSAI/9436AV



**Section**  
**English**

**1**

# Description of Controls— Mark II, Tilt-To-Unload Washer-Extractor

MSOURLCTAE/9433AV



## Master switch

This switch controls single-phase control circuit power to the machine and the DC power supply for the microprocessor and its components. Setting this switch to  during operation stops the machine.







## Operator Signal

This signal is activated when operator attention is required, as when unloading is required or certain errors occur. Pressing  cancels the signal.





## Signal Cancel button

This button extinguishes the operator signal () . If the signal was programmed as part of a formula, the formula resumes after this button is pressed. If an error caused  to illuminate, pressing  after correcting the error will extinguish the signal. If  was illuminated when a valid formula was selected, the signal will terminate automatically when the formula is started or the door is opened.



## Run/Program keyswitch

Setting the keyswitch to  prevents programmed data from being changed and allows normal machine operation. Setting the keyswitch to  allows programming machine operation and certain troubleshooting procedures.

## No symbol Emergency Stop button

This large red button in a yellow rectangle may appear in several locations on the machine. It performs the same function as , but locks in the depressed position and must be turned to release the button and close the circuit before operation can resume.

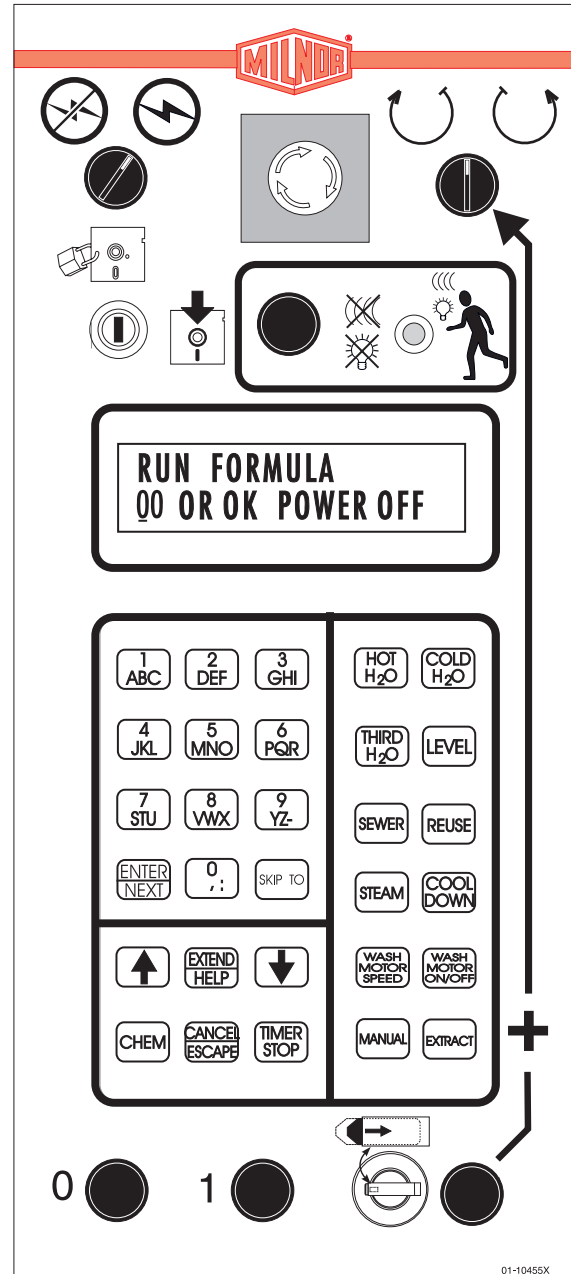

01-10455X

①

### Stop button

This button stops the machine immediately by opening the three-wire circuit. Emergency Stop buttons perform the same function. Pull cords and kick plates, if the machine has them, also perform the same function.

②

### Start button



This button starts a cycle or resumes an interrupted cycle if a formula is selected and certain safety considerations are met.

It is also used with other controls listed in this section.



### Door Open button



This button retracts the door plunger to unlock the door if the machine is not running.

Pressing ① +  jogs the cylinder clockwise or counter-clockwise as set by  / .



### Jog switch

This switch determines the direction the cylinder will rotate when jogging is commanded.

Holding the switch at  jogs clockwise; holding the switch at  jogs counter-clockwise.



### Balance Sensing light—ExN and balancing Hydro-Cushion® models

This light is extinguished while the imbalance exceeds preset limits.



### Balance Valve lights—balancing models

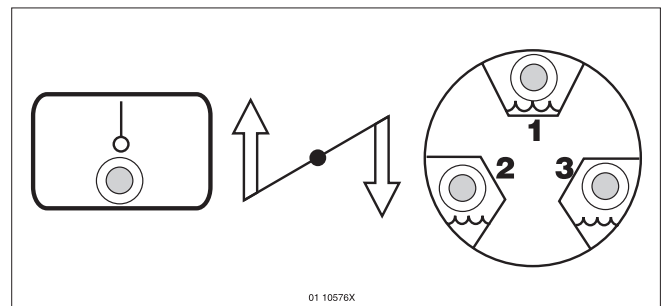

These lights show which balancing valves are open. They are extinguished when balancing is complete, except for intermittent operation as the balancing system compensates for changes in the imbalance. Lights that stay on through most extractions may indicate inadequate water supply to the balancing system or that the balancing system requires service.

Service is required if all three lights illuminate at the same time.





**Manual Flush/Spray switch—machines with five-compartment supply injectors**

Hold this switch to  to flush water into the first compartment of the supply injector. Hold this switch to  to use the spray nozzle to clean the supply injector.

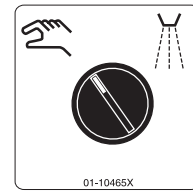
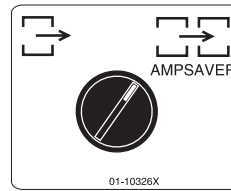

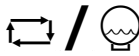
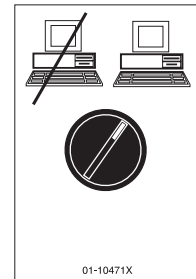
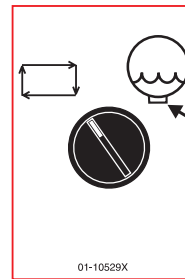
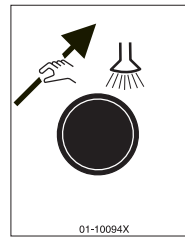

**Manifold Flush button**

Press this button to flush the chemical supply manifold with fresh water.





**Alternate Drain switch**

Set this switch to  to disable all machine functions and hold the drain closed. The machine can be powered off with the drain closed for overnight soaking. Set to  to permit normal operation.





**Mildata Remote/Local switch—Mildata option**

Set this switch to  to have the machine communicate with the Mildata computer. Set to  to use internal machine formulas.









**Ampsaver switch—Ampsaver option**

 causes the Ampsaver controller to delay extraction when necessary to prevent the amperage drawn by all machines from exceeding a preset maximum.  prevents the Ampsaver controller from affecting machine operation.









**Up/Down Tilt switch—QTx, WTx, and BTx models**

To tilt the machine, set  /  for the desired tilting direction, then hold  + . Hold  +  to return the cylinder to the normal position.



**Hydraulic Door switch—Models with motorized doors**

Pressing  +  closes the door if a formula is not running.  +  opens the door if a formula is not running.

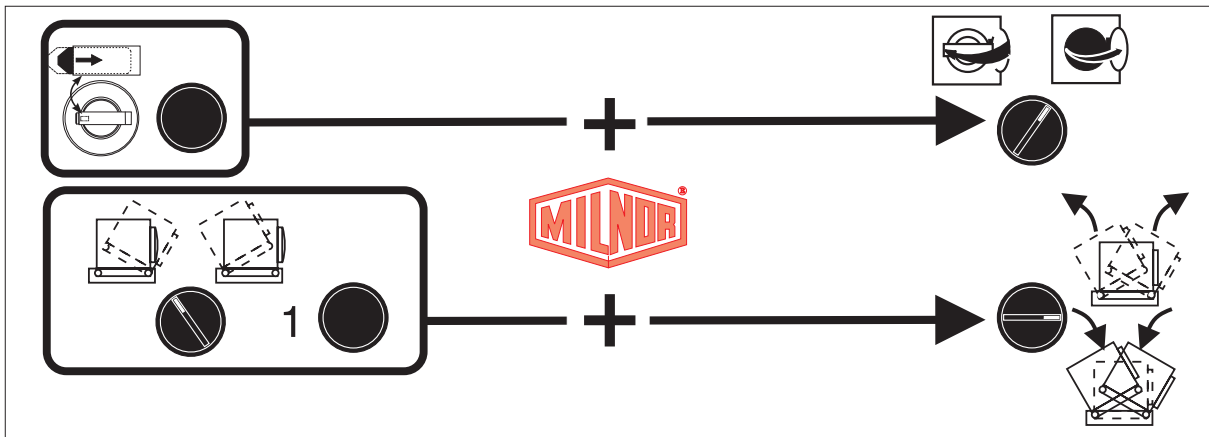



# Normal Operation—Mark II, Tilt-To-Unload Washer-Extractor

MSOUPLN0AE/9433AV

## Start the Operating Day.

**Be Safe.** Comply with all safety instructions in this manual and on this machine.

### Verify Switch Positions.

Switch Symbol	Selection	Switch Setting by Name/Function
 / 		Set the Run/Program keyswitch to run.

**Energize Microprocessor Controller.** Set the Master switch to on (☞). The operator signal sounds and a series of displays appear.

RUN FORMULA  
00 OR OK POWER OFF

Machine is ready for a load.

REMOTE FORMULA 0000

Machine is on-line to Mildata and ready for a load. See “Enter Cake Data If Machine On-Line to Mildata.”

**Enter Cake Data if the Machine is On-Line to Mildata.** The machine prompts for cake data. Enter a value, and press **NEXT** for each prompt.

Display Message	Valid Values	Description
enter FORMULA for the machine	000-255	Wash formula number
enter REMOTE FORMULA	000-999	Wash formula number
enter W/ORDER	000-999	Work order number for accounting
ENTER EXTRACTOR CODE FOR the machine	00-15	Extractor code for this load
enter DRY CODE for the machine	00-15	Dry code for this load
enter DESTINATION for the machine	000-255	Shuttle discharge destination
enter CUSTOMER code for the machine	000-999	Customer code for accounting
enter GOODS CODE for the machine	000-999	Goods code for this load
enter PIECES for the machine	000-999	Quantity information for accounting
enter soil WEIGHT for the machine	00-99	Weight information for accounting
ENTER CAKE NUMBER FOR the machine	000-255	Cake number for handling
ENTER LOAD SIZE FOR the machine	0, 1	0 for full load, 1 for partial load to determine dry code
enter EMPLOYEE NUMBER	000-999	Employee number for accounting
enter LOT NUMBER	000-999	Lot number for accounting

**Table A: Possible Cake Data**

## Run the Wash Cycle.



### **DANGER: Explosion and Fire Hazards**

Flammable substances can explode or ignite in the cylinder, drain trough, or sewer. The machine is designed for washing with water, not any other solvent. Processing can cause solvent-containing goods to give off flammable vapors.

☞ Do not use flammable solvents in processing.

☞ Thoroughly flush all flammable-soiled goods with multiple cold baths before any hot bath. Consult with your local fire department/public safety office and all insurance providers.

## Compose the load.

1. Separate tangled linen.
2. Size loads as determined locally. Overloading may reduce wash quality. Under loading may inhibit extraction.

## Load the machine.

### Close the door.

- Manual door— Swing the door closed with enough force to latch it.
- Power operated door— Simultaneously hold the Door Open button (☞) and hold the Hydraulic Door switch to close (☞). Continue to hold until the door latches.
- NOTE: Closing the door sounds the operator signal if a formula was previously selected.



**Add chemicals, if required.** Chemical supplies may be added manually or automatically, depending on the optional hardware furnished and the formulas used. The possible methods are as follows:

- Automatically inject chemicals with a pumped chemical or central liquid supply system.
- Load the supply injector before starting the cycle. Supplies are flushed in automatically.
- Re-load supply injector compartments or manually flush compartment one during the cycle, when prompted by the formula.
- Pour supplies through the soap chute before or during the cycle.

Because the injection method, formulas, and chemicals to be used are determined in the field, the operator procedures for adding chemicals are determined locally. See the reference manual for further information on the optional supply injector, liquid supply injection, and formulas.

**Select a formula.** If the machine is on-line to a Mildata computer, see "Enter Cake Data." The available formulas are listed in the Run Formula menu.

RUN FORMULA  
00 OR OK POWER OFF

Enter a formula number (two digit number from 01 to 98) or scroll through the available formulas by pressing  or . See the reference manual for information on permanent formulas 00 and 99.

RUN FORMULA  
DOES NOT EXIST

Appears if a non-existent formula is selected.

**Start the cycle.** When the operator signal is sounding (door closed and formula selected), press the Start button (①).

**Respond to the end of cycle.** The operator signal will sound when the cycle ends. It may also sound during the cycle if operator attention is required. Check the display.

STOPPED  
PLEASE UNLOAD ME

The cycle is completed.

XXXXXXXX  
PLEASE UNLOAD ME

"TUMBLING"—If desired, open the door, pull the goods down, close the door, then press the Start button (①) to continue tumbling for two minutes. "REVERSING" or "DRAIN SPEED"—Press the Signal Cancel button () to stop cylinder motion and complete the cycle.

 **DANGER: Entangle and Sever Hazards**



Contact with goods being processed can cause the goods to wrap around your body or limbs and dismember you. The goods are normally isolated by the locked cylinder door.

 Do not attempt to open the door or reach into the cylinder until the cylinder is stopped.

 **WARNING: Scald Hazards**



Contact with hot bath liquor can scald you. Bath liquor can pour from the door or spray out of ports on the cylinder.

 Do not open the cylinder door with water in the cylinder.

 **DANGER: Strike and Crush Hazards**



Machines with power operated door—The moving door can strike you or crush or pinch your limbs if caught between the door and machine. Some doors move automatically.

 Keep yourself and others clear of movement areas and paths.



 Do not operate the machine with malfunctioning two-hand manual controls.

**Open the door.** Safeguards prevent the door from opening while a formula is in progress and immediately after manually terminating a formula.









 **DANGER: Crush Hazards**



**Tilting machines only—The machine can crush your body or limbs if you are caught between the tilting housing and a stationary object. Some machines tilt automatically.**

-  **Keep yourself and others clear of movement areas and paths.**
-  **Keep both hands on the controls while operating.**
-  **Do not operate the machine with malfunctioning two-hand manual controls.**



**Tilt forward to unload.** Place the cart or other receiving device under the door, then tilt as follows:

- Models 48032BTx, 48036QTx, 52038WTx, 72044WTx—Set the Rear/Front Tilt switch ( / ) to Rear (). Simultaneously hold the Start button (①) and hold the Up/Down Tilt switch ( / ) to up (). Hold until the desired tilt angle is reached or the machine stops at its forward limit.
- Models 64046E6N, 72046E5N—Simultaneously hold the Start button (①) and hold the Up/Down Tilt switch ( / ) to up (). Hold until the desired tilt angle is reached or the machine stops at its forward limit.



 **DANGER: Entangle and Sever Hazards**



**Contact with goods being processed can cause the goods to wrap around your body or limbs and dismember you.**

-  **Open pocket machines only—Do not jog the cylinder and pull the goods at the same time.**
-  **Keep yourself and others clear of movement areas and paths.**
-  **Do not operate the machine with malfunctioning two-hand manual controls.**

**Jog to discharge the goods.**

1. Simultaneously hold the Start button (①) and the Jog switch ( or ). The cylinder turns until buttons are released.
2. Change rotation direction and rotate again, if necessary.

**Return to non-tilted position from tilt forward.** Simultaneously hold the Start button (①) and hold the Up/Down Tilt switch ( / ) to down (). Hold until the machine reaches its non-tilted position.

## Monitor Normal Operation

When the door is closed, normal run displays similar to those below will appear.

Level not satisfied; no chemicals actuated:	10:38 F0005S03 02:37 dF=A093/D140 * HC3	alternates with	10:38 STEP 03 02:37 WAIT FOR LEVEL 2 HC3
Level satisfied; no chemicals actuated:	10:38 F0005S03 02:37 dF=A093/D140 LEV1	alternates with	10:38 STEP 03 02:37 dF=A093/D140 SPD 0
Chemicals or signal actuated:	10:38 F0005S03 02:37 02-04 SOAP+ALKALI	alternates with	10:38 STEP 03 02:37 02-04 SOAP+ALKALI
Draining:	DRAINING TO SEWER 01:20 20RPM		
Extracting:	05:30 F0005S06 05:30 LO SPD EXT 0450 RPM	alternates with	05:30 EXTRACT 05:30 LO SPD EXT 0450 RPM

Data	What it Means	Data	What it Means
<b>Bath Steps</b>			
10:38	Formula time remaining	STEP 03	Step name
F000	Formula number	WAIT FOR LEVEL 2	Waiting for desired level
S03	Step number	WAIT FOR LEV 10"	Electronic level sensing waiting for 10 inches (or cm)
02:37	Step time remaining	W=A00125/D00135	Metered water: A=achieved, D=desired
dF/dC	Bath temperature (°F/°C) if temp probes configured; A=achieved, D=desired	SPD 0	If speed is programmable: 0=low, 1=high. Shows RPM for variable speed machines.
*	Level achieved: * (below low), 1, 2, 3	02-04	Chemical number and name number (alternates for multiple chemicals)
HC3	Water valves on: Hot, Cold, 2nd, 3rd	SOAP+ALKALI	Chemical name (alternates for multiple chemicals)
<b>Drain/Extract Steps</b>			
01:20	Drain time remaining	LO SPD EXT	Extract speed (shows HI for single speed)
20RPM	Actual speed if configured for RPM sensing and variable speed		

# Correcting Errors—Mark II Washer-Extractor

MSOUPUTSAE/9436AV

**Interruptions Repairable by the Operator**—These errors can usually be corrected at the operator controls.

THREE WIRE DISABLED  
any message

The three-wire relay supplying control circuit power to the machine was de-energized or power was restored to the machine after a shutdown or power loss.

RECOVERY: Press ① to close the three-wire circuit. If the three-wire circuit remains disabled or another message appears on the display, request authorized service.

ACCUM. DATA ERROR  
NEXT TO CLEAR DATA

Accumulator data is unreliable.

RECOVERY: Press **NEXT** to clear accumulator data and resume operation.

LOST WATER DATA  
NEXT TO PROCEED

The water data is unreliable.

RECOVERY: Press **NEXT** so the controller prompts for information. The machine resumes operation. NOTE: If this machine does not have metered water, request management assistance to ensure that the configure values match the equipment.

MANUAL EXTRACT :  
MUST HAVE LEVEL 2

Level 2 was not achieved before an extract was manually commanded.

RECOVERY: Manually command level 2. Permit time to achieve this level, then manually command extract. Continue manual operation. Press **⌘** to resume operation.

## Interruptions Requiring Management Assistance

—These errors usually require accessing program data and procedures found in the reference manual.

CLEAR MEMORY NOW  
PRESS 4 + 5 + 6

Program data was corrupted.

RECOVERY: Request management assistance to clear the memory and reprogram the machine. Return to run mode to resume operation.

CONFIG ERROR  
TURN KEY TO PROGRAM

Configure data was corrupted.

RECOVERY: Request management assistance to reconfigure the machine. Return to run mode to resume operation.



name FAILED  
CHECK THIS BOARD

A circuit board is failed or is missing.

RECOVERY: Press **ESCAPE**. Request management assistance to verify that configure values match the equipment. If the message returns, request authorized service.

INVALID PASSWORD

An invalid password was entered during manual intervention.

RECOVERY: Enter a valid password.

INVALID WORK ORDER

The work order number is not in Mildata memory.

RECOVERY: Enter a valid number.

INVALID GOODS CODE

The goods code is not in Mildata memory.

RECOVERY: Enter a valid number.

INVALID CUST CODE

The customer code is not in Mildata memory.

RECOVERY: Enter a valid number.

INVALID EMPLOYEE #

The employee number is not in Mildata memory.

RECOVERY: Enter a valid number.

INVALID FORMULA

The formula number is not in Mildata memory.

RECOVERY: Enter a valid number.

INVALID FORM DATA

The formula data received from Mildata is invalid.

RECOVERY: Request management assistance to verify the formula data in Mildata.

DATA UNLOCATABLE

Mildata could not locate formula data for the machine requested.

RECOVERY: Request management assistance to verify that the machine is configured properly in Mildata.

**Interruptions Requiring Authorized Service**—These errors usually require accessing mechanical or electrical components. Request authorized service in accordance with published safety information. See the safety manual.

*-KEY PAD ERROR-* key name	A keypad key was stuck or shorted.
-------------------------------	------------------------------------

RECOVERY: Request authorized service.

BRAKE FAULT, MUST BE CLEARED TO RESTART	The brake pressure switch detected insufficient air pressure in the brake release air cylinder to guarantee brake has released.
--	---

RECOVERY: Request authorized service. The message clears when the switch detects adequate pressure.

normal run message CHECK LEVEL SWITCH	The level switch malfunctioned.
--	---------------------------------

RECOVERY: Request authorized service.

normal run message CHECK type PROBE	The steam or water temperature probe malfunctioned.
--	---

RECOVERY: Request authorized service.

SPEED SWITCH OPEN	The speed switch circuit is open.
-------------------	-----------------------------------

RECOVERY: If the cylinder is stationary, request authorized service. The message clears when the circuit closes.

normal run message RECYCLE FAILURE	The machine recycled five times in a single extract step. The machine attempts to balance the load by repeating the previous step.
---------------------------------------	--

RECOVERY: If the message returns, request authorized service.

normal run message TOO LONG TO COOL	The configured cooldown time was exceeded.
--	--

RECOVERY: Request authorized service to check the cooldown system. The message clears when cooldown temperature is reached.

normal run message  
TOO LONG TO FILL

The configured fill time was exceeded.

**RECOVERY:** Request authorized service to check the water supply system. The message clears when the machine fills.

normal run message  
TOO LONG TO STEAM

The configured time to reach desired steam temperature was exceeded.

**RECOVERY:** Request authorized service to check the steam system. The message clears when the temperature is reached.

## Interruptions That Self-recover

AMPSAVER HALT

Ampsaver is preventing extraction until the current drawn by other machines in the system falls below a specified level. The message clears when extraction begins. **NOTE:** This message should appear only if the machine is on line to an Ampsaver system

MILTRENCH HALT

Miltrench is preventing this machine from draining until other machines finish draining. The message clears when draining begins. **NOTE:** This message should appear only if the machine is on line to a Miltrench system.



**Section**  
**Français**

**2**

# Description des Commandes— Mark II, Laveuse-essoreuse à renversement Avant

MSOURLCTAF/9433AV



## Interrupteur

Cet interrupteur commande l'alimentation du circuit 1 phase à la machine et fournit le courant continu au microprocesseur et à ses composants. Si l'on pousse  pendant le fonctionnement, la machine s'arrête.







## Signal opérateur

Ce signal se déclenche pour demander l'attention de l'opérateur, comme par exemple pendant le déchargement ou lorsque certaines erreurs se produisent. Si l'on pousse  le signal s'annule.





## Bouton d'annulation du signal

Ce bouton éteint le signal opérateur . Si le signal était programmé comme faisant partie d'une formule, la formule reprend lorsque le bouton est poussé. Si une erreur déclenche , l'allumage du signal, en poussant  après correction de l'erreur, éteint le signal. Si  était allumé pendant la sélection d'une formule valide, le signal s'arrête automatiquement quand la formule démarre ou lorsque la porte est ouverte.



## Interrupteur à clé marche/ programmation

Le réglage de l'interrupteur à clé sur  empêche la modification des informations programmées et permet le fonctionnement normal de la machine. Le réglage de l'interrupteur à clé sur  permet la programmation de la machine et certaines procédures de dépiége des pannes.

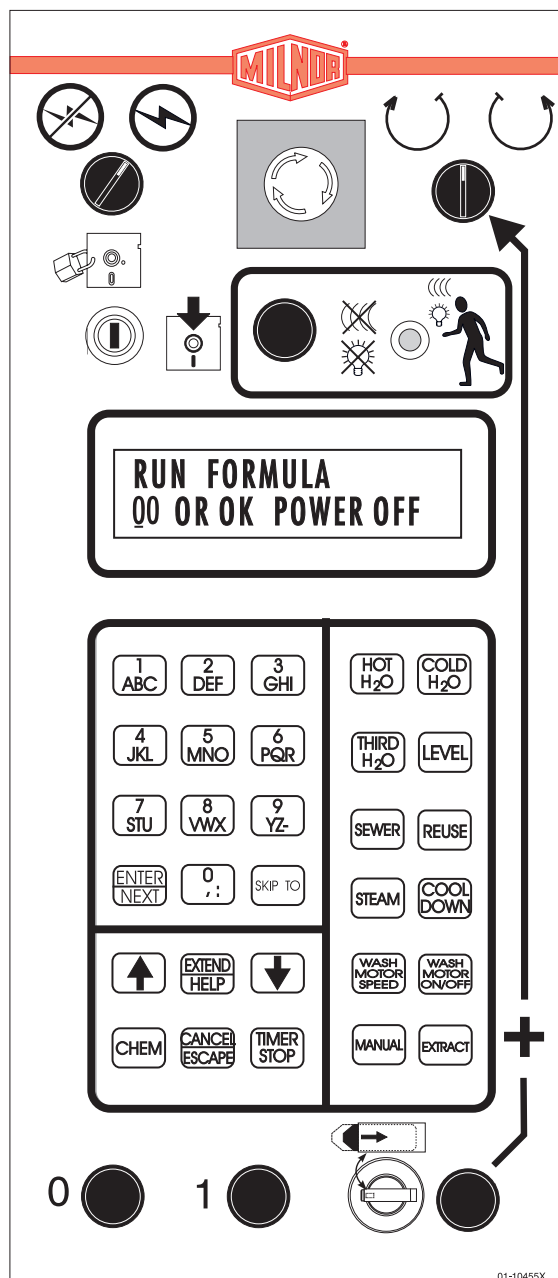

01-10455X

**pas de symbole** **Bouton d'arrêt d'urgence**

Ce gros bouton rouge dans un rectangle jaune est placé dans différents endroits de la machine. Il a la même fonction que ①, mais se verrouille lorsqu'il est poussé et il doit être tourné pour se relâcher et fermer le circuit, avant que le fonctionnement puisse reprendre.

①

**Bouton d'arrêt**

Ce bouton arrête la machine immédiatement en ouvrant le circuit des 3 fils. Les arrêts d'urgence ont la même fonction. Les cordes à tirer et les pédales, si la machine en est équipée, ont la même fonction.

①

**Bouton marche**



Ce bouton démarre le cycle ou reprend un cycle interrompu lorsqu'une formule est sélectionnée et lorsque certaines conditions de sécurité sont rencontrées.

Est aussi utilisé avec d'autres commandes indiquées dans cette section.





**Bouton d'ouverture de porte**

Ce bouton retracte le piston de la porte pour déverrouiller celle-ci lorsque la machine ne fonctionne pas.

Si l'on pousse ① +  le tambour fait des secousses dans le sens horaire ou dans le sens contraire comme réglé par  / .



**Interrupteur de secousses**

Cet interrupteur détermine le sens de rotation du tambour pendant les secousses. Si l'on pousse  la rotation se fait dans le sens horaire. Si l'on pousse  la rotation se fait dans le sens contraire au sens horaire.

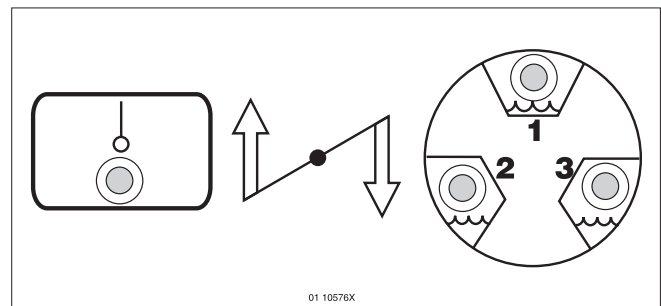

**Voyant du capteur d'équilibre—Modèles ExN et balancing Hydro-Cushion®**

Ce voyant s'éteint pendant que le déséquilibre excède les limites de l'essorage à grande vitesse.





**Voyants de la Vanne d'équilibre—Modèles à équilibrage.**

Ces voyants indiquent les vannes d'équilibre qui sont ouvertes. Ils s'éteignent lorsque l'équilibrage est atteint, sauf pour une opération intermittente comme le système d'équilibrage compense pour les changements dans le déséquilibre. Les voyants qui restent allumés pendant plusieurs essorages peuvent indiquer un manque d'eau dans le système d'équilibrage ou que le système a besoin de maintenance.

La maintenance est nécessaire si les 3 voyants s'allument en même temps.



### Interrupteur de mouillage/vaporisation manuels—Machines avec 5 compartiments d'injecteurs produits.

Maintenir cet interrupteur sur  pour introduire de l'eau dans le 1er compartiment de l'injecteur de produit. Maintenir cet interrupteur sur  pour utiliser le vaporisateur pour nettoyer l'injecteur de produit.



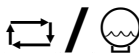

### Bouton de mouillage du Manifold

Pousser le bouton pour mouiller le Manifold de produit avec de l'eau neuve.





### Interrupteur de vidange alternée.

Positionner cet interrupteur sur  pour mettre hors service les fonctions de la machine et maintenir la vidange fermée. La machine peut être mise hors courant avec la vidange fermée pour un trempage pendant la nuit. Positionner sur  pour permettre un fonctionnement normal.





### Interrupteur à distance/local du Mildata— Option Mildata

Positionner cet interrupteur sur  pour que la machine communique avec l'ordinateur Mildata. Positionner sur  pour utiliser les formules de la machine interne.



### Interrupteur Ampsaver—Option Ampsaver



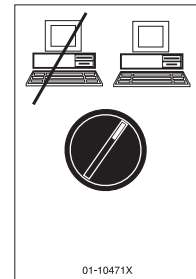
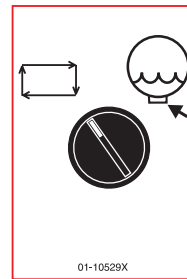
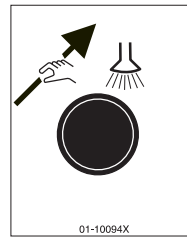
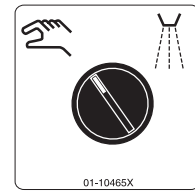
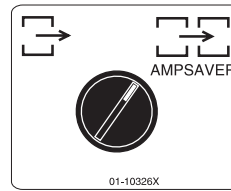

 fait retarder par le contrôleur Ampsaver le temps d'essorage pour éviter que toutes les machines excèdent l'ampérage maximum préétabli.  évite au contrôleur Ampsaver d'affecter le fonctionnement de la machine.











**Interrupteur de basculement haut / bas—Modèles QTx, WTx, et BTx.**

Pour basculer la machine, régler  /  à la direction de basculement désiré, puis maintenir  + ①. Maintenir  + ① pour que le tambour retourne en position normale.



**Interrupteur de porte hydraulique—Modèle avec porte automatique**

Pressing  +  closes the door if a formula is not running.  +  opens the door if a formula is not running.

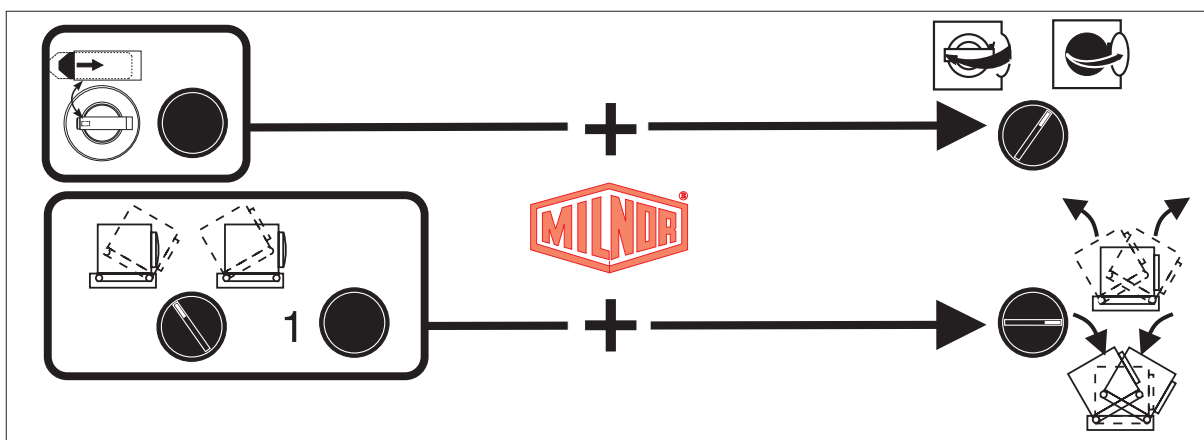

# Fonctionnement courant—Mark II, Laveuse-essoreuse à renversement Avant

MSOUPLN0AF/9433AV

## Démarre le jour de mise en fonctionnement.

**Soyez prudent.** Se conformer aux instructions de sécurité décrites dans ce livre et sur la machine.

### Vérifier les positions des interrupteurs.

Symbole des  
interrupteurs

Selection

Positionnement des interrupteurs par noms/fonctions



Positionner l'interrupteur à clé sur "Marche/programme" sur marche.

**Alimenter le boîtier de commande du microprocesseur.** Positionner l'interrupteur principal sur marche (☺). Le signal opérateur se déclenche et une série d'affichages apparait.

CHOIX PROGRAMME  
00 PANNE COURANT

Machine prête pour une charge.

FORMUL DISTANC 0000

Machine en ligne avec le MILDATA et prête pour une charge. Voir "Entrer données galette si la machine est en ligne avec le Mildata".

**Entrer données galette si la machine est en ligne avec le Mildata.** La machine demande les données galette. Entrer une valeur, et presser **NEXT** pour chaque demande.

message de l'écran	Valeurs valides	Description
entrer FORMULE pour la machine	000-255	Numéro formule de lavage
Entrer FORMULE A DISTANCE	000-999	Numéro formule lavage
entrer W/ORDER	000-999	Numéro de commande pour comptabilité
Entrer essorage code pour la machine	00-15	Code d'essorage pour cette charge
Entrer code sechage pour la machine	00-15	Code séchage pour cette charge
Entrer destination pour la machine	000-255	Destination déchargement navette
Entrer code client pour la machine	000-999	Code client pour comptabilité
Entrer code linge pour la machine	000-999	Code client pour comptabilité
Entrer pieces pour la machine	000-999	Information quantité pour comptabilité
Entrer poids linge sale pour la machine	00-99	Information poids pour comptabilité
Entrer numero galette pour la machine	000-255	Numéro galette pour manutention
Taille charge pour la machine	0, 1	0 pour une charge complète, 1 pour une charge partielle pour déterminer le code séchage
Entrer numero de l'employe	000-999	Numéro de l'employé pour comptabilité
entrer le numéro de lot	000-999	Numéro de lot pour comptabilité

**Tableau A : les différentes données de galette possible**

## Commencer le cycle de lavage.

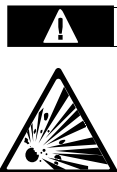

### **DANGER: Risques d'explosion et de feu**

Les substances inflammables peuvent exploser ou prendre feu dans le tambour, les vidanges ou égout. La machine est destinée au lavage avec de l'eau, mais pas avec du solvant. Le processus peut entraîner une évaporation de vapeur inflammable contenue dans le linge contenant du solvant.

☞ Ne pas utiliser des solvants inflammables dans le processus.

☞ Mouiller soigneusement tout le linge sali par des matières inflammables avec plusieurs bains froids avant de le mettre dans un bain chaud. Consulter votre centre de secours d'incendie et votre assureur.

## Composer la charge.

1. Retirer le linge emmêlé.
2. Les tailles des charges sont faites sur place. Une surcharge peut réduire la qualité de lavage. Une charge réduite pourrait nuire à l'essorage.

## Charger la machine.

### Fermer la porte.

- Porte manuelle— Fermer la porte énergiquement pour la verrouiller.
- Alimentation d'opération porte— Maintenir simultanément le bouton de porte ouverte (☞) et le bouton de porte hydraulique pour fermer (☞). Continuer de les maintenir jusqu'au verrouillage de porte.
- NOTE: la fermeture de porte déclenche le signal opérateur si une formule a été sélectionnée précédemment.

**Ajouter les produits, si nécessaire.** Les produits peuvent être ajoutés manuellement ou automatiquement, suivant l'option du matériel fourni et les formules utilisées. Les méthodes possibles sont les suivantes:

- Injection automatique de produits par pompe ou centrale lessivielle.
- Remplir l'injecteur de produit avant de commencer le cycle. Les produits sont injectés automatiquement.
- Re-charger les bacs des injecteurs de produits ou arroser manuellement le compartiment 1 pendant le cycle si demandé par la formule.
- Verser les produits dans le bac avant ou pendant le cycle.

La méthode d'injection, les formules et produits sont déterminés par l'opérateur suivant son installation. Voir le manuel d'utilisation pour les informations sur les injecteurs en option, les injections de produits liquides et les formules.

**Sélectionner une formule.** Si la machine est raccordée à un ordinateur MILDATA., voir "Entrer donnée galette". Les formules disponibles sont listées dans le menu marche formule.

CHOIX PROGRAMME  
00 PANNE COURANT

Entrer un numéro de formule (2 digits de 01 à 98) ou dérouler les formules disponibles en pressant  ou . Voir le livre technique pour information sur les formules permanentes 00 et 99.

CHOIX PROGRAMME  
NEXISTE PAS

Apparait si une formule non-existante est sélectionnée.

**Commencer le cycle.** Quand le signal opérateur se déclenche (porte fermée et formule sélectionnée) presser le bouton marche (①).

**Correspond à la fin du cycle.** Le signal opérateur se déclenche quand le cycle est terminé. Il peut également se déclencher pendant le cycle si l'attention de l'opérateur est nécessaire. Vérifier l'écran.

STOPPED  
PLEASE UNLOAD ME

Le cycle est terminé.

XXXXXXXX  
DECHARGER MACHINE

"DEMELAGE"—Si besoin, ouvrir la porte, retirer le linge, fermer la porte, puis presser le bouton marche (①) pour continuer le démêlage pendant 2 minutes. "INVERSION" ou "VITESSE VIDANGE"—Presser le bouton annulation signal () pour arrêter le tambour et terminer le cycle.



**DANGER: Risques d'enchevêtrement et risques sérieux**



Le contact avec du linge en traitement peut entraîner le linge autour de votre corps ou de vos membres et vous démembrer. Le linge est normalement protégé par le verrouillage de la porte du tambour.

☞ Ne pas essayer d'ouvrir la porte ou de toucher au tambour tant que celui-ci n'est pas arrêté.



**AVERTISSEMENT : Risques d'ébouillantage**



Le contact avec un liquide lessiviel chaud peut vous ébouillanter. L'eau lessivielle peut couler de la porte ou passer à travers les perforations du tambour.

☞ Ne pas ouvrir la porte du tambour avec de l'eau à l'intérieur.



**DANGER: Risques de coups et d'écrasement**



Machines avec ouverture de porte hydraulique— La porte en mouvement peut vous heurter ou écraser ou pincer vos membres s'ils sont attrapés entre la porte et la machine. Certaines portes sont automatiques.

☞ Eloignez vous et éloignez les autres des endroits de passage de matériel en mouvement.



☞ N'utilisez pas une machine ayant une commande manuelle défectueuse.

**Ouvrir la porte.** Les sécurités empêchent l'ouverture de la porte pendant le cycle d'une formule et immédiatement après l'avoir arrêté manuellement.









 **DANGER: Risques d'écrasement**



**Machines tilting seulement—la machine peut écraser votre corps ou vos membres si vous êtes attrapés entre la machine basculante et un objet. Certaines machines basculent automatiquement.**

-  **Eloignez vous et éloignez les autres des endroits de passage de matériel en mouvement.**
-  **Garder vos 2 mains sur les commandes pendant les opérations.**
-  **N'utilisez pas une machine ayant une commande manuelle défectueuse.**



**Basculement avant pour déchargement.** Placer le chariot ou autre appareil de réception sous la porte, puis basculer comme suit:

- Modèles 48032BTx, 48036QTx, 52038WTx, 72044WTx—Positionner le bouton de basculement avant/arrière ( / ) sur arrière (). Maintenir simultanément le bouton marche (①) et maintenir le switch de basculement haut/bas ( / ) sur haut (). Maintenir jusqu'à l'obtention de l'angle de basculement désiré, sinon le basculement s'arrête à son maximum.
- Modèles 64046E6N, 72046E5N—Maintenir simultanément le bouton marche (①) et le switch de basculement haut/bas ( / ) sur haut (). Maintenir jusqu'à l'obtention de l'angle de basculement désiré, sinon le basculement s'arrête à son maximum.



 **DANGER: Risques d'enchevêtrement et risques sérieux**



**Le contact avec du linge en traitement peut entraîner le linge autour de votre corps ou de vos membres et vous démembrer.**

-  **Machines open-pocket seulement—Ne pas faire des secousses au tambour et tirer le linge en même temps.**
-  **Eloignez vous et éloignez les autres des endroits de passage de matériel en mouvement.**
-  **N'utilisez pas une machine ayant une commande manuelle défectueuse.**

**Faire des secousses pour décharger le linge.**

1. Maintenir simultanément le bouton marche (①) et le bouton de secousses ( ou ). Le tambour tourne jusqu'à ce que les boutons soient relâchés.
2. Changer le sens de rotation et tourner encore, si nécessaire.

**Retour du basculement avant à la position debout.** Maintenir simultanément le bouton marche (①) et le switch de basculement haut/bas ( / ) sur bas (). Maintenir jusqu'à ce que la machine revienne en position normale.

## Moniteur Fonctionnement Courant

Quand la porte est fermée, les écrans de marche similaires à ceux ci-dessous apparaîtront.

Niveau non satisfait; pas de produits activés:	10:38 F0005S03 02:37 dF=A093/D140 * HC3	alterne avec	10:38 STEP 03 02:37 WAIT FOR LEVEL 2 HC3
Niveau satisfait; pas de produits activés:	10:38 F0005S03 02:37 dF=A093/D140 LEV1	alterne avec	10:38 STEP 03 02:37 dF=A093/D140 SPD 0
Produits ou signaux activés:	10:38 F0005S03 02:37 02-04 SOAP+ALKALI	alterne avec	10:38 STEP 03 02:37 02-04 SOAP+ALKALI
En vidange:	DRAINING TO SEWER 01:20 20RPM		
En essorage:	05:30 F0005S06 05:30 LO SPD EXT 0450 RPM	alterne avec	05:30 EXTRACT 05:30 LO SPD EXT 0450 RPM

Donnée	ce qui veut dire	Donnée	ce qui veut dire
<b>étapes du bain</b>			
10:38	Temps formule restant	STEP 03	Nom étape
F000	Numero formule	WAIT FOR LEVEL 2	En attente niveau désiré
S03	Numero d'étape	WAIT FOR LEV 10"	Sonde de niveau électronique en attente de 25 cm
02:37	Temps d'étape restant	W=A00125/D00135	Eau mesurée. A=atteint, D=désiré
dF/dC	Température du bain(°F/°C ) si sonde de température configurée; A=achevée, D=désirée	SPD 0	Si la vitesse est programmable:0=basse, 1=grande. Indique le nombre de tours minute des machines à vitesse variable.
*	Niveau atteint: * (en-dessous de bas), 1, 2, 3	02-04	Numero du produits et numero du nom (en alternance pour plusieurs produits)
HC3	Vannes d'eau sur: chaud, froid, 2ème, 3ème	SOAP+ALKALI	Nom du produit (en alternance pour plusieurs produits)
<b>étapes vidange/essorage</b>			
01:20	Temps vidange restant	LO SPD EXT	Vitesse essorage (indique HI our une seule vitesse)
20RPM	Vitesse actuelle si configurée pour nombre de tours minute et vitesse variable		

# Correction des Erreurs—Mark II

## Laveuse-essoreuse

MSOUPUTSAF/9436AV

**Arrêts remédiables par l'opérateur**—Ces erreurs peuvent être corrigées par les commandes de l'opérateur.

THREE WIRE DISABLED  
any message

Le relais 3 fils alimentant le circuit de commande de la machine est hors tension ou le courant a été rétabli après un arrêt ou une coupure du courant.

RETABLISSEMENT : Pousser ① pour couper le circuit 3 fils. Si le circuit reste inactif ou qu'un autre message apparaît sur l'écran, appeler le personnel spécialisé.

ACCUM. DATA ERROR  
NEXT TO CLEAR DATA

La donnée de l'accumulateur n'est pas fiable.

RETABLISSEMENT : Presser **NEXT** pour vider l'accumulateur et continuer l'opération.

LOST WATER DATA  
NEXT TO PROCEED

La donnée d'eau n'est pas fiable.

RETABLISSEMENT : Presser **NEXT** pour que l'automate demande une information. La machine continue l'opération. Note : si la machine n'a pas de mesure d'eau, s'assurer avec le responsable que les valeurs configurées correspondent avec l'équipement.

MANUAL EXTRACT :  
MUST HAVE LEVEL 2

Le niveau n'était pas atteint quand un essorage manuel a été demandé.

RETABLISSEMENT : Commande manuellement le niveau 2. Donne le temps d'atteindre ce niveau, commande manuellement l'essorage. Continuer en opération manuelle. Presser **⌘** pour continuer l'opération

## Interruptions demandant l'assistance de la direction

—Ces erreurs demandent l'accès aux informations du programme et aux procédures décrites dans le livre technique.

CLEAR MEMORY NOW  
PRESS 4 + 5 + 6

L'information du programme est altérée.

RETABLISSEMENT: Demander l'assistance du responsable pour vider la mémoire et reprogrammer la machine. Retourner au mode marche pour continuer l'opération.

CONFIG ERROR  
TURN KEY TO PROGRAM

L'information de configuration était altérée.

RETABLISSEMENT: Demander l'assistance du responsable pour reconfigurer la machine. Retourner au mode marche pour continuer l'opération.



name FAILED  
CHECK THIS BOARD

Une carte du circuit est défectueuse ou est manquante.

RETABLISSEMENT : Presser **ESCAPE**. Demander l'assistance du responsable pour vérifier que les valeurs configurées correspondent à l'équipement. Si le message revient, appeler le personnel spécialisé.

INVALID PASSWORD

Un mot de passe invalide a été entré pendant l'intervention manuelle.

RETABLISSEMENT : Entrer un mot de passe valide.

INVALID WORK ORDER

Le numero d'ordre de travail n'est pas dans la mémoire du mildata.

RETABLISSEMENT : Entrer un n° valide.

INVALID GOODS CODE

Le code de catégories n'est pas dans la mémoire du mildata.

RETABLISSEMENT : Entrer un n° valide.

INVALID CUST CODE

Le code client n'est pas dans la mémoire du mildata.

RETABLISSEMENT : Entrer un n° valide.

INVALID EMPLOYEE #

Le numéro de l'employé n'est pas dans la mémoire du mildata.

RETABLISSEMENT : Entrer un n° valide.

INVALID FORMULA

Le numéro de formule n'est pas dans la mémoire mildata.

RETABLISSEMENT : Entrer un n° valide.

INVALID FORM DATA

L'information de formule reçue du mildata est invalide.

RETABLISSEMENT : Demander l'assistance du responsable pour vérifier l'information formule dans le mildata.

DATA UNLOCATABLE

Le mildata n'a pas localisé l'information formule que la machine a demandé.

RETABLISSEMENT : Demander l'assistance du responsable pour vérifier que la machine est bien configurée en mildata.

## Interruptions demandant le service d'opérateurs spécialisés

—Ces erreurs demandent normalement l'accès aux composants mécaniques ou électriques. Demander l'assistance du service spécialisé conformément aux règles de sécurité publiées.

\*-KEY PAD ERROR-\*  
key name

Une touche de clavier a été enfoncée ou raccourcie.

RETABLISSEMENT: Demander le service spécialisé.

BRAKE FAULT, MUST BE  
CLEARED TO RESTART

Le switch de pression de freinage détecte une insuffisance d'air comprimé dans le verin de relachement pour garantir le freinage.

RETABLISSEMENT: Demander le service spécialisé. Le message disparaît quand le switch détecte une pression adéquate.

normal run message  
CHECK LEVEL SWITCH

Le switch de niveau a mal fonctionné.

RETABLISSEMENT: Demander le service spécialisé.

normal run message  
CHECK type PROBE

La sonde de température vapeur ou d'eau a mal fonctionné.

RETABLISSEMENT: Demander le service spécialisé.

SPEED SWITCH OPEN

Le circuit du switch de vitesse est ouvert.

RETABLISSEMENT : Si le tambour est stationnaire, demander le personnel spécialisé. Le message disparaît lorsque le circuit se ferme.

normal run message  
RECYCLE FAILURE

La machine se recycle 5 fois dans une seule étape d'essorage. La machine essaie d'équilibrer la charge en répétant l'étape précédente.

RETABLISSEMENT : Si le message réapparaît, appeler le personnel spécialisé.

normal run message  
TOO LONG TO COOL

Le temps de refroidissement configuré est dépassé.

RETABLISSEMENT : Demander au personnel spécialisé de vérifier le système de refroidissement. Le message s'efface quand la température de refroidissement est atteinte.

normal run message  
TOO LONG TO FILL

Le temps de remplissage configuré est dépassé.

**RETABLISSEMENT** : Demander au personnel spécialisé de vérifier le système d'arrivée d'eau. Le message s'efface quand la machine est remplie.

normal run message  
TOO LONG TO STEAM

Le temps configuré pour atteindre la température vapeur désirée est dépassé.

**RETABLISSEMENT** : Demander au personnel spécialisé de vérifier le système vapeur. Le message s'efface quand la température est atteinte.

## Interruptions qui s'auto-rétablissent

AMPSAVER HALT

L'ampsaver empêche l'essorage tant que le courant utilisé par d'autres machines du système n'est pas abaissé à un certain niveau. Le message s'efface quand l'essorage commence. Note : Le message apparaît seulement si la machine est dans un système ampsaver.

MILTRENCH HALT

Miltrench empêche la machine de vidanger tant que les autres n'ont pas terminé de vidanger. Le message s'efface quand la vidange commence. Note: Le message apparaît seulement si la machine est dans un système miltrench.



**Section**  
**Deutsch**

**3**

# Beschreibung der Steuerung— Mark II, Kippbare Maschine (kipubar bei Entladung)

MSOUPLECTAG/9433AV



## Hauptschalter

Dieser Schalter kontrolliert die Stromzufuhr für den einphasigen Steuerschaltkreis und die Gleichstromzufuhr zum Mikroprozessor und dessen Baugruppen. Drücken von  während des Betriebes stoppt die Maschine.







## Bedienersignal

Dieses Signal wird ausgelöst, wenn die Aufmerksamkeit des Bedieners erforderlich ist, z. B. wenn die Maschine entladen werden muß oder bestimmte Fehler auftreten. Drücken von  löscht das Signal.





## Taster für Signalaufhebung

Dieser Taster löscht das Bedienersignal () . Wenn das Signal in einem Programm enthalten ist, setzt das Programm nach Betätigung dieses Tasters wieder ein. Leuchtet  aufgrund eines Fehlers auf, löscht  das Signal nach Behebung des Fehlers. Wenn nach Auswahl eines gültigen Programms  leuchtet, wird das Signal automatisch gelöscht, sobald das Programm gestartet oder die Tür geöffnet wird.



## Schlüsselschalter für Betrieb/Programmierung (Run/Program)

Drehen des Schlüsselschalters auf  verhindert, daß programmierte Daten geändert werden, und erlaubt normalen Maschinenbetrieb. Drehen des Schlüsselschalters auf  erlaubt die Programmierung des Maschinenbetriebes und bestimmte Verfahren der Fehlersuche.

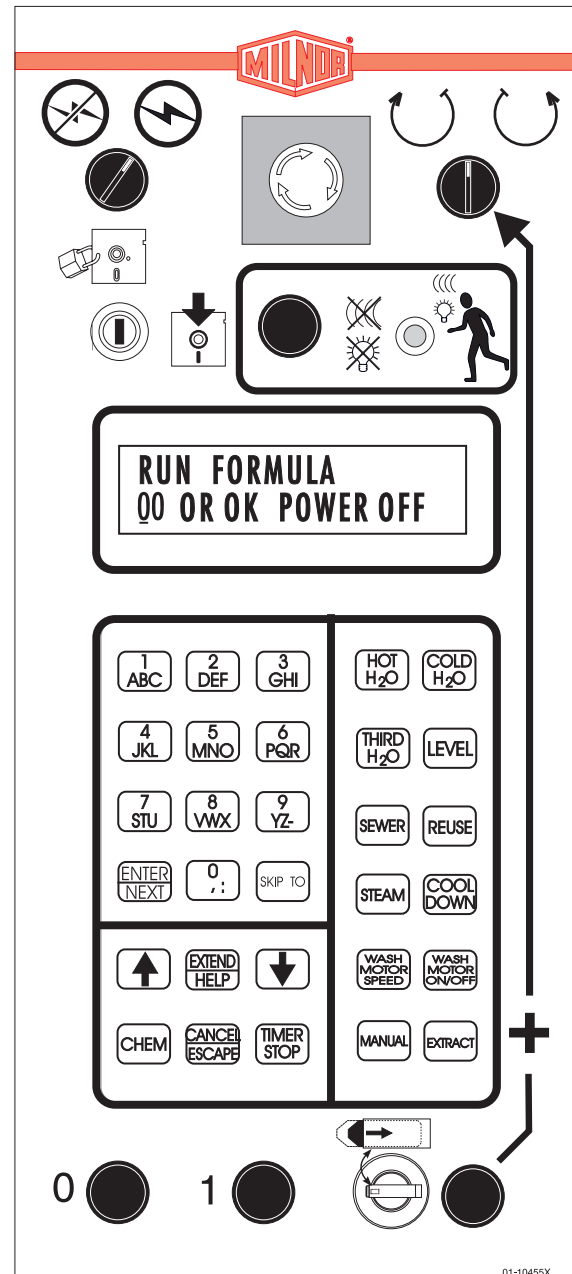

01-10455X

## Kein Symbol 1NOTAUS-Schalter

Dieser große rote Taster in einem gelben Rechteck kann an mehreren Stellen der Maschine gefunden werden. Er hat dieselbe Funktion wie ①, rastet aber in gedrückter Position ein. Er wird durch Drehung wieder entlastet, wobei sich der Stromkreis schließt, bevor der Betrieb wieder aufgenommen werden kann.

①

### Aus-Schalter

Dieser Schalter stoppt die Maschine sofort durch Unterbrechung der drei Phasen. NOTAUS-Schalter erfüllen denselben Zweck, ebenso Zugleinen und Trittplatten (wenn vorhanden).

①

### Start-Taster



Dieser Taster startet einen Prozeß oder nimmt einen unterbrochenen Prozeß wieder auf, wenn ein Programm gewählt und bestimmte Sicherheitsvorkehrungen getroffen worden sind.

Er wird auch im Zusammenhang mit anderen Steuerungselementen benutzt, die in diesem Abschnitt aufgeführt sind.





### Taster für "Tür öffnen" (Door Open)

Dieser Taster fährt den Türbolzen ein, um bei nicht-laufender Maschine die Tür zu entriegeln.

Drücken von ① +  dreht die Trommel im Jogging-Betrieb je nach Stellung von  /  im Uhrzeigersinn oder entgegen dem Uhrzeigersinn.



### Schalter für Jogging-Betrieb

Dieser Schalter bestimmt den Drehsinn der Trommel bei eingestelltem Jogging-Betrieb. Bei Betätigung von  dreht sie sich im Uhrzeigersinn, bei Betätigung von  entgegen dem Uhrzeigersinn.



### Lampe für Unwuchtüberwachung—bei ExN-Maschinen und ausgleichsfähigen Hydro-Cushion®-Modellen

Diese Lampe erlischt, wenn die Unwucht die Grenzwerte für schnelles Schleudern überschreitet.



### Lampen für Ausgleichsventile —bei Modellen mit Unwuchtausgleich

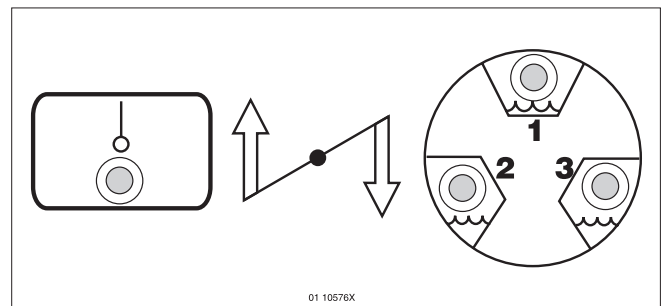

Diese Lampen zeigen an, welche Ausgleichsventile geöffnet sind. Sie erlöschen, wenn der Unwuchtausgleich abgeschlossen ist - außer bei zwischengeschalteten Operationen, in denen das System Unwuchtänderungen ausgleicht. Lampen, die während des Schleuderns meistens erleuchtet bleiben, weisen möglicherweise darauf hin, daß sich zu wenig Wasser im Ausgleichssystem befindet oder das System gewartet werden muß.

Wartung ist erforderlich, wenn alle drei Lampen gleichzeitig leuchten.





### Schalter für manuelles Ausspülen/Ausspritzen —bei Maschinen mit Fünf-Kammer-Einspritzung

Halten Sie diesen Schalter auf , um Wasser in die erste Kammer des Einspritzinjektors zu spülen. Halten Sie diesen Schalter auf , um mit der Einsprühdüse den Injektor zu säubern.

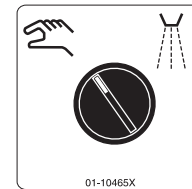
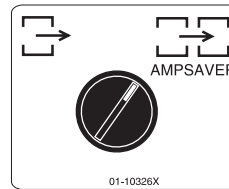

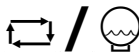
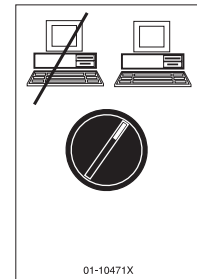
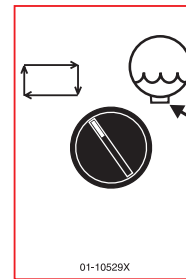
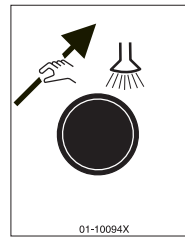

### Spültaster für Verteilerrohr

Drücken Sie diesen Schalter, um das Verteilerrohr für die Chemikalienzufuhr mit Frischwasser durchzuspülen.





### Schalter für Entwässerungssperre

Stellen Sie diesen Schalter auf , um alle Maschinenfunktionen zu sperren und den Ablauf geschlossen zu halten. Die Maschine kann ausgeschaltet werden, wobei der Ablauf über Nacht zum Einweichen geschlossen bleibt. Stellen Sie den Schalter auf , um normalen Betrieb zu erlauben.





### Mildata-Schalter für Fern/Direkt-Steuerung—Mildata-Option

Stellen Sie diesen Schalter auf , um die Maschine mit dem Mildata-Computer kommunizieren zu lassen. Stellen Sie ihn auf , um interne Maschinenprogramme zu nutzen.







### Schalter für Ampsaver —Ampsaver-Option

 bewirkt, daß der Ampsaver-Controller das Schleudern verzögert, wenn dies erforderlich ist, um zu verhindern, daß der von allen Maschinen aufgenommene Strom ein vorbestimmtes Maximum überschreitet.  verhindert, daß der Ampsaver-Controller den Maschinenbetrieb beeinflußt.







### Schalter für Auf-/Ab-Kippen —bei QTx-, WTx- und BTx-Modellen

Um die Maschine zu kippen, stellen Sie  /  für die gewünschte Kipprichtung ein. Dann halten Sie . Mit  schwenken Sie die Trommel in die normale Position zurück.



### Hydraulischer Türschalter —Modelle mit Türmotor

Pressing  closes the door if a formula is not running.  opens the door if a formula is not running.

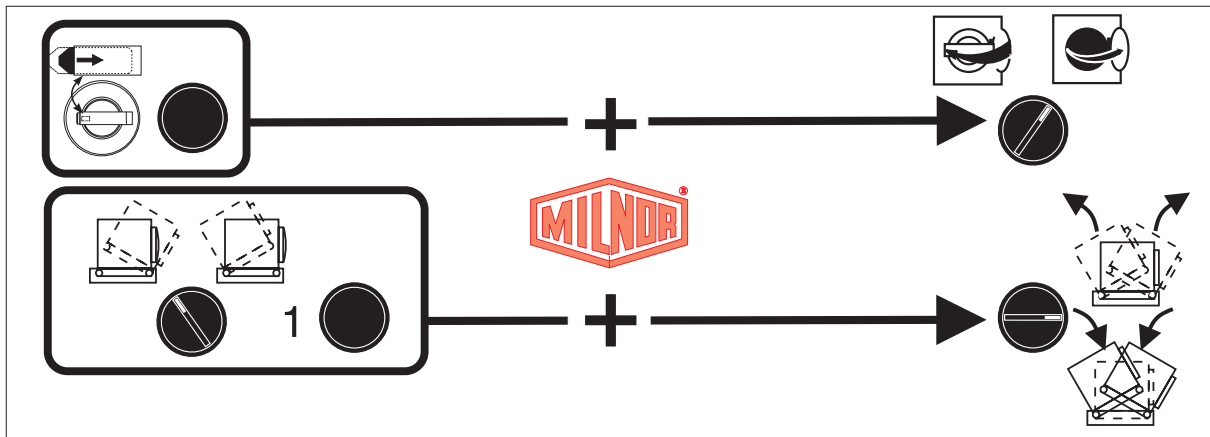

# Normalbetrieb—Mark II, Kippbare Maschine (kipptbar bei Entladung)

MSOUPLNOAG/9433AV

## Arbeitstag beginnen.

**Gehen Sie auf Nummer Sicher.** Halten Sie alle Sicherheitsvorschriften ein, die sich in diesem Handbuch und an der Maschine befinden.

## Vergewissern Sie sich über die Schalterstellungen.

Schaltersymbol	Auswahl	Schalterstellung	Name/Funktion
----------------	---------	------------------	---------------



Drehen Sie den "Run/Program"-Schlüsselschalter auf "Run".

**Setzen Sie die Mikroprozessor-Steuerung in Betrieb.** Stellen Sie den Hauptschalter auf . Das akustische Warnsignal setzt ein, und eine Folge von Anzeigen erscheint.

PROGRAMM NR. 00 OK Z. ABSCHALTEN
-------------------------------------

Maschine ist ladebereit.

PROG.FERNEING. 0000
---------------------

Maschine ist mit Mildata verbunden und ladebereit. Siehe "Wäschekuchen-Daten eingeben, wenn die Maschine an Mildata angeschlossen ist."

**Wäschekuchen-Daten eingeben, wenn die Maschine an Mildata angeschlossen ist.** Die Maschine fragt Wäschekuchen-Daten ab. Geben Sie einen Wert ein und drücken Sie **NEXT** für jede Abfrage.

Mitteilung der Anzeige	Gültige Werte	Beschreibung
PROGRAMM für die Maschine eingeben	000-255	Nummer des Waschprogramms
FERNPROGRAMM eingeben	000-999	Nummer des Waschprogramms
Auftragsnummer eingeben	000-999	Auftragsnummer für die Abrechnung
Schleuder-kode eingeben für die maschine	00-15	Schleuder-Kode für diese Ladung
Trockner-kode eingeben für die Maschine	00-15	Trockner-Kode für diese Ladung
Zielpunkt eingeben für die maschine	000-255	Zielpunkt für das Verfahrband
Kunden-Nummer eingeben für die Maschine	000-999	Kunden-Nummer für die Abrechnung
Artikelnummer eingeben für die Maschine	000-999	Kunden-Nummer für Abrechnung
TEILE eingeben für die maschine	000-999	Mengen-Information für die Abrechnung
Schmutz-gewicht eingeben für die maschine	00-99	Gewichts-Information für die Abrechnung
Nummer des wäschekuchens eingeben für die maschine	000-255	Wäschekuchen-Nummer für Handhabung
Ladungsgröße eingeben für die maschine	0, 1	0 für volle Ladung, 1 für Teilladung zur Bestimmung des Trockner-Kodes
Mitarbeiter-nummer eingeben	000-999	Mitarbeiter-Nummer für die Abrechnung
Haufen-nummer eingeben	000-999	Haufen-Nummer für Abrechnung

**Tabelle A: Mögliche Wäschekuchen-Daten**

## Waschvorgang starten



### **VORSICHT GEFAHR: Explosions- und Brandgefahr**



Entflammbare Substanzen können Explosionen oder Feuer in der Trommel, in den Entwässerungsdurchgängen oder in der Kanalisation auslösen. Die Maschine ist für das Waschen mit Wasser ausgelegt, für keinerlei andere Lösungsmittel. Die Bearbeitung lösungsmittelhaltiger Artikel kann zur Absonderung entflammbarer Gase führen.

☞ Verwenden Sie keine entflammbaren Lösungsmittel für die Bearbeitung.

☞ Spülen Sie alle mit entflammbaren Stoffen verschmutzten Artikel gründlich in mehreren Bädern durch, bevor Sie diese einem heißen Bad aussetzen. Ziehen Sie die örtliche Feuerwehr, zuständige öffentliche Anlaufstellen sowie die Versicherungsunternehmen zu Rate.

### **Stellen Sie die Ladung zusammen.**

1. Trennen Sie Artikel, die ineinander verwickelt sind.
2. Begrenzen Sie die Ladungen Größenmäßig nach den individuellen Anforderungen. Überbeladung kann die Waschqualität verringern. Unterbeladung kann die Entwässerung hemmen.

### **Beladen Sie die Maschine.**

#### **Schließen Sie die Tür.**

- Manuelle Tür— Schlagen Sie die Tür mit ausreichender Kraft zu, um sie einrasten zu lassen.
- Elektrisch betriebene Tür— Halten Sie zum Schließen den Türöffnungstaster (☞) und den Tür-Hydraulikschalter gleichzeitig betätigt (☞). Halten Sie sie so lange betätigt, bis die Tür einrastet.
- ANMERKUNG: Das Schließen der Tür löst das Bediener signal aus, wenn vorher ein Programm gewählt wurde.



**Führen Sie Chemikalien zu, wenn erforderlich.** Je nach Maschinenausstattung und Programm können Chemikalien manuell oder automatisch zugeführt werden. Folgende Methoden sind möglich:

- Führen Sie Chemikalien automatisch mittels eines Pumpensystems oder eines zentralen Flüssigchemikaliensystems zu.
- Füllen Sie den Chemikalien trichter vor Beginn des Prozesses. Der Inhalt wird automatisch eingespült.
- Füllen Sie die Kammern des Chemikalien trichters wieder auf oder spülen Sie Kammer 1 während des Waschprozesses manuell durch, wenn dies im Programm vorgesehen ist.
- Gießen Sie die Chemikalien vor oder während des Waschprozesses in den Seifenbehälter.

Weil nach dem Verfahren mit Chemikalien trichter Programm und zu verwendende Chemikalien je nach Anwendungsfall bestimmt werden, werden auch die Bedienungsvorgänge individuell festgelegt. Weitere Informationen zum optionsweise mitgelieferten Chemikalien trichter, zur Flüssigchemikalien zugebe und zu den Waschprogrammen finden Sie im Bedienungshandbuch.

**Wählen Sie ein Programm.** Wenn die Maschine an einen Milda-Computer angeschlossen ist, siehe "Eingabe von Wäschekuchen-Daten". Die verfügbaren Programme werden im Programm Menü aufgelistet.

PROGRAMM NR.  
00 OK Z. ABSCHALTEN

Geben Sie eine Programmnummer ein (zweistellig von 01 bis 98), oder rollen Sie durch die verfügbaren Programme, indem Sie  oder  drücken. Beachten Sie das Bedienungshandbuch bezüglich der festen Programme 00 bis 99.

PROGRAMM NR.  
EXIST.-NICHT

erscheint, wenn ein nicht-existentes Programm ausgewählt wurde.

**Starten Sie den Prozeß.** Wenn das Bedienersignal ertönt (bei geschlossener Tür und ausgewähltem Programm), drücken Sie den Start-Taster (①).

**Reagieren Sie auf das Ende des Prozesses.** Das Bedienersignal ertönt, wenn der Waschprozeß endet. Ebenso kann es während des Prozesses ertönen, wenn die Aufmerksamkeit des Bedieners erforderlich ist. Prüfen Sie die Anzeige.

STOPPED  
PLEASE UNLOAD ME

Der Waschprozeß ist beendet.

XXXXXXXXX  
MASCHINE ENTLADEN

Wenn gewünscht, öffnen Sie die Tür, ziehen die Artikel heraus, schließen die Tür und drücken dann den Start-Taster (①), um die Trommelrotation für zwei Minuten fortzusetzen. "REVERSING" oder "DRAIN SPEED" (Entwässerungsdrehzahl) —Drücken Sie den Schalter zum Signallöschen (✖), um die Trommelbewegung zu beenden und den Prozeß zu vervollständigen.



**VORSICHT GEFAHR: Gefahr von Einwicklung und ernsthaften Verletzungen**



Berührung von Artikeln während ihrer Bearbeitung kann bewirken, daß sich die Artikel um Körper oder Gliedmaßen wickeln und diese abtrennen. Im Normalfall sind die Artikel durch die geschlossene Tür abgeschirmt.

☞ Versuchen Sie nicht, die Tür zu öffnen oder in die Trommel zu greifen, bevor diese zum Stillstand gekommen ist.



**WARNING: Verbrühgefahr**



Kontakt mit heißer Waschlauge kann Verbrennungen verursachen. Waschlauge kann von der Tür lecken oder aus der Trommel spritzen.

☞ Öffnen Sie niemals die Trommeltür, wenn sich in der Trommel Wasser befindet.



**VORSICHT GEFAHR: Stoß- und Quetschgefahr**



Bei Maschinen mit kraftbetriebener Tür—Die sich bewegende Tür kann Stoßverletzungen hervorrufen oder Gliedmaßen einklemmen oder einquetschen, wenn diese zwischen Tür und Maschine gelangen. Einige Türen bewegen sich automatisch.

☞ Halten Sie sich und andere von den Fahrbereichen und -wegen der Anlage fern



☞ Betreiben Sie die Maschine nicht bei fehlerhafter Zwei-Hand-Steuerung.

**Öffnen Sie die Tür.** Sicherheitseinrichtungen verhindern das Öffnen der Tür, während ein Programm läuft, und unmittelbar nach manueller Beendigung eines Programms.









 **VORSICHT GEFAHR: Quetschgefahr**



Nur bei kippbaren Maschinen—Die Maschine kann Gliedmaßen einklemmen oder einquetschen, wenn Sie zwischen das kippbare Gehäuse und einen ortsfesten Gegenstand geraten. Einige Maschinen kippen automatisch.

-  Halten Sie sich und andere von den Fahrbereichen und -wegen der Anlage fern
-  Bedienen Sie die Steuerungselemente stets beidhändig.
-  Betreiben Sie die Maschine nicht bei fehlerhafter Zwei-Hand-Steuerung.



**Kippen Sie die Maschine zum Entladen nach vorn.** Plazieren Sie den Wäschewagen oder ein entsprechendes Transportmittel unter der Tür. Dann leiten Sie das Kippen wie folgt ein:

- Bei 48032BTx, 48036QTx, 52038wtx und 72044WTx Modellen—Stellen Sie den Schalter für das Kippen nach hinten/vorn ( / ) auf "nach hinten" (). Halten Sie den Start-Taster (①) betätigt, und halten Sie gleichzeitig den Schalter für Kippen auf/ab ( / ) auf "auf" (), bis der gewünschte Neigungswinkel erreicht ist oder die Maschine an ihrem vorderen Grenzscharter stoppt.
- Bei 64046E6N und 72046E5N Modellen—Halten Sie den Start-Taster (①) betätigt, und halten Sie gleichzeitig den Schalter für Kippen auf/ab ( / ) auf "auf" (), bis der gewünschte Neigungswinkel erreicht ist oder die Maschine an ihrem vorderen Grenzscharter stoppt.



 **VORSICHT GEFAHR: Gefahr von Einwicklung und ernsthaften Verletzungen**





Berührung von Artikeln während ihrer Bearbeitung kann bewirken, daß sich die Artikel um Körper oder Gliedmaßen wickeln und diese abtrennen.

-  Nur bei Open-Pocket-Maschinen—Rütteln oder drehen Sie niemals an der Trommel, wenn gleichzeitig die Wäsche entnommen wird.
-  Halten Sie sich und andere von den Fahrbereichen und -wegen der Anlage fern
-  Betreiben Sie die Maschine nicht bei fehlerhafter Zwei-Hand-Steuerung.

**Setzen Sie den Jogging-Betrieb zum Entladen der Artikel ein.**

1. Halten Sie den Start-Taster (①) und den Türöffnungstaster ( oder ) gleichzeitig gedrückt. Die Trommel dreht sich, bis die Schalter entlastet werden.
2. Ändern Sie den Drehsinn und drehen Sie erneut, falls notwendig.

**Kippen Sie die Maschine aus der vorderen Position in die**

**Ausgangsstellung zurück.** Halten Sie den Start-Taster (①) betätigt, und halten Sie gleichzeitig den Schalter für Kippen auf/ab ( / ) auf "ab" (), bis die Maschine ihre Ausgangsposition erreicht hat.

## Normalbetrieb überwachen

Bei geschlossener Tür erscheinen die normalen Betriebs-Anzeigen (Run-Displays) ähnlich den unten angezeigten.

Niveau nicht erreicht; keine Chemikalien zugeführt:	10:38 F0005S03 02:37 dF=A093/D140 * HC3	wechselt mit	10:38 STEP 03 02:37 WAIT FOR LEVEL 2 HC3
Niveau erreicht; keine Chemikalien zugeführt:	10:38 F0005S03 02:37 dF=A093/D140 LEV1	wechselt mit	10:38 STEP 03 02:37 dF=A093/D140 SPD 0
Chemikalien zugeführt oder Signal ausgelöst:	10:38 F0005S03 02:37 02-04 SOAP+ALKALI	wechselt mit	10:38 STEP 03 02:37 02-04 SOAP+ALKALI
Entwässern:	DRAINING TO SEWER 01:20 20RPM		
Schleudern:	05:30 F0005S06 05:30 LO SPD EXT 0450 RPM	wechselt mit	05:30 EXTRACT 05:30 LO SPD EXT 0450 RPM

Daten	Bedeutung	Daten	Bedeutung
<b>Bad-Schritte</b>			
10:38	Verbleibende Programmdauer	STEP 03	Schrittname
F000	Programm-Nummer	WAIT FOR LEVEL 2	Warten auf gewünschtes Niveau
S03	Schrittnummer	WAIT FOR LEV 10"	Elektronische Niveauekontrolle wartet auf 10 Zoll (oder cm)
02:37	Verbleibende Schrittdauer	W=A00125/D00135	Angezeigtes Niveau: A=erreicht (achieved), D=gewünscht (desired)
dF/dC	Badtemperatur (°F/°C), wenn Temperaturfühler konfiguriert; A=erreicht , D=gewünscht	SPD 0	Bei programmierbarer Drehzahl: 0=niedrig, 1=hoch. Für Maschinen mit veränderlicher Drehzahl werden die Umdrehungen pro Minute angezeigt.
*	Niveau erreicht: * (unterhalb niedrig), 1, 2, 3	02-04	Chemikalien-Nummer und Name (wechselt für mehrere Chemikalien)
HC3	Wasserventile geöffnet: warm, kalt, zweites, drittes	SOAP+ALKALI	Chemikalien-Name (wechselt für mehrere Chemikalien)
<b>Entwässerungs-/Schleuder-Schritte</b>			
01:20	Verbleibende Entwässerungszeit	LO SPD EXT	Schleuderdrehzahl (zeigt HI
20RPM	Tatsächliche Geschwindigkeit, wenn konfiguriert für Drehzahlmessung und veränderliche Drehzahl		

# Fehlerbehebung—Mark II, Wasch-Schleuder-Maschine

MSOUPUTSAG/9436AV

## Unterbrechungen, die für den Bediener behebbar sind

—Diese Fehler können gewöhnlich mittels der Bedienungselemente behoben werden.

THREE WIRE DISABLED  
any message

Das Drehstrom-Relay, durch das die Maschine den Steuerstrom erhält, war stromlos, oder die Stromversorgung an die Maschine wurde nach einer Stilllegung oder einem Stromausfall wieder eingeschaltet.

BEHEBUNG: Drücken Sie ①, um den Drehstromkreis zu schließen. Bleibt dieser dennoch inaktiv, oder erscheint eine neue Fehlermeldung, fordern Sie autorisiertes Wartungspersonal an.

ACCUM. DATA ERROR  
NEXT TO CLEAR DATA

Zählzeiten sind unzuverlässig.

BEHEBUNG: Drücken Sie **NEXT**, um die Zählzeiten zu löschen und den Betrieb wieder aufzunehmen.

LOST WATER DATA  
NEXT TO PROCEED

Die Wasserdaten sind unzuverlässig.

BEHEBUNG: Drücken Sie **NEXT**, damit der Controller Daten abfragt. Die Maschine nimmt den Betrieb wieder auf. ANMERKUNG: Falls die Maschine keinen kalibrierten Wasserstand besitzt, bitten Sie die Wäschereileitung um Hilfe, um sicherzustellen, daß die konfigurierten Werte der tatsächlichen Ausrüstung entsprechen.

MANUAL EXTRACT :  
MUST HAVE LEVEL 2

Niveau 2 wurde nicht erreicht, bevor von Hand das Schleudern eingeleitet wurde.

BEHEBUNG: Leiten Sie Niveau 2 von Hand ein. Lassen Sie dafür entsprechend Zeit, anschließend veranlassen Sie von Hand das Schleudern. Setzen Sie den Handbetrieb fort. Drücken Sie **✕\***, um den Betrieb wieder aufzunehmen.

## Unterbrechungen, bei denen Unterstützung durch die Wäschereileitung erforderlich ist

—Diese Fehler erfordern üblicherweise den Zugang zu Programmdateien und -abläufen, die im Bedienungshandbuch zu finden sind.

CLEAR MEMORY NOW  
PRESS 4 + 5 + 6

Programmdateien wurden verfälscht.

BEHEBUNG: Bitten Sie die Wäschereileitung um Hilfe, um den Speicher zu löschen und Maschine neu zu programmieren. Kehren Sie in den Betriebsmodus (Run-Modus) zurück, um den Betrieb wieder aufzunehmen.

CONFIG ERROR  
TURN KEY TO PROGRAM

Konfigurationsdateien wurden verfälscht.

BEHEBUNG: Bitten Sie die Wäschereileitung um Hilfe, um die Maschine neu zu konfigurieren. Kehren Sie in den Betriebsmodus (Run-Modus) zurück, um den Betrieb wieder aufzunehmen.



name FAILED  
CHECK THIS BOARD

Eine Schaltkarte ist fehlerhaft oder nicht vorhanden.

BEHEBUNG: Drücken Sie **ESCAPE**. Bitten Sie die Wäschereileitung um Hilfe und stellen Sie sicher, daß die Konfigurationsdaten der Ausstattung entsprechen. Erscheint die Meldung erneut, fordern Sie autorisiertes Wartungspersonal an.

INVALID PASSWORD

Bei einem manuellen Eingriff wurde ein ungültiges Paßwort eingegeben.

BEHEBUNG: Geben Sie ein gültiges Paßwort ein.

INVALID WORK ORDER

Die Auftragsnummer ist nicht im Mildata-Speicher enthalten.

BEHEBUNG: Geben Sie eine gültige Nummer ein.

INVALID GOODS CODE

Die Artikelnummer ist nicht im Mildata-Speicher enthalten.

BEHEBUNG: Geben Sie eine gültige Nummer ein.

INVALID CUST CODE

Die Kundennummer ist nicht im Mildata-Speicher enthalten.

BEHEBUNG: Geben Sie eine gültige Nummer ein.

INVALID EMPLOYEE #

Die Mitarbeiternummer ist nicht im Mildata-Speicher enthalten.

BEHEBUNG: Geben Sie eine gültige Nummer ein.

INVALID FORMULA

Die Programmnummer ist nicht im Mildata-Speicher enthalten.

BEHEBUNG: Geben Sie eine gültige Nummer ein.

INVALID FORM DATA

Die von Mildata empfangenen Programmdateien sind ungültig.

BEHEBUNG: Bitten Sie die Wäschereileitung um Hilfe und überprüfen Sie die in Mildata gespeicherten Programmdateien.

DATA UNLOCATABLE

Mildata konnte die Programmdateien für die gewünschte Maschine nicht zuweisen.

BEHEBUNG: Bitten Sie die Wäschereileitung um Hilfe und überprüfen Sie, ob die Maschine in Mildata korrekt konfiguriert ist.

## Unterbrechungen, bei denen **Wartung durch autorisiertes Personal erforderlich ist**—Diese Fehler

machen üblicherweise den Zugang zu mechanischen und elektrischen Bauteilen erforderlich. Fordern Sie eine Wartung durch autorisiertes Personal und in Übereinstimmung mit den veröffentlichten Sicherheitshinweisen an. Beachten Sie hierzu das Bedienungshandbuch.

\*-KEY PAD ERROR-\*  
key name

Eine Taste der Tastatur klemmte.

**BEHEBUNG:** Fordern Sie autorisiertes Wartungspersonal an.

BRAKE FAULT, MUST BE  
CLEARED TO RESTART

Der Bremsdruck-Schalter signalisierte unzureichenden Luftdruck im Luftzylinder für die Entlastung der Bremse, so daß eine einwandfreie Entlastung nicht garantiert ist.

**BEHEBUNG:** Fordern Sie autorisiertes Wartungspersonal an. Die Fehlermeldung wird gelöscht, wenn der Schalter ausreichenden Druck feststellt.

normal run message  
CHECK LEVEL SWITCH

Der Niveauschalter reagierte fehlerhaft.

**BEHEBUNG:** Fordern Sie autorisiertes Wartungspersonal an.

normal run message  
CHECK type PROBE

Der Temperaturfühler für Dampf oder Wasser reagierte fehlerhaft.

**BEHEBUNG:** Fordern Sie autorisiertes Wartungspersonal an.

SPEED SWITCH OPEN

Der Schaltkreis des Geschwindigkeitsschalters ist geöffnet.

**BEHEBUNG:** Bei nicht-bewegender Trommel fordern Sie autorisiertes Wartungspersonal an. Die Fehlermeldung wird gelöscht, wenn der Schaltkreis geschlossen wird.

normal run message  
RECYCLE FAILURE

Die Maschine setzte fünfmal ein bei einem einzigen Schleudergang. Sie versucht, die Ladung durch das Wiederholen des vorherigen Schrittes auszuwuchten.

**BEHEBUNG:** Wenn die Fehlermeldung erneut erscheint, fordern Sie autorisiertes Wartungspersonal an.

normal run message  
TOO LONG TO COOL

Die konfigurierte Cooldown-Zeit wurde überschritten.

**BEHEBUNG:** Fordern Sie autorisiertes Wartungspersonal an, um das Cooldown-System zu überprüfen. Die Fehlermeldung erlischt, wenn die Cooldown-Temperatur erreicht ist.

normal run message  
TOO LONG TO FILL

Die konfigurierte Füllzeit wurde überschritten.

**BEHEBUNG:** Fordern Sie autorisiertes Wartungspersonal an, um die Wasserversorgung zu überprüfen. Die Fehlermeldung erlischt, wenn sich die Maschine füllt.

normal run message  
TOO LONG TO STEAM

Die konfigurierte Zeit zum Erreichen der gewünschten Dampftemperatur wurde überschritten.

**BEHEBUNG:** Fordern Sie autorisiertes Wartungspersonal an, um die Dampfversorgung zu überprüfen. Die Fehlermeldung erlischt, wenn die Temperatur erreicht ist.

## **Unterbrechungen, die sich ohne äußeren Eingriff selbständig beheben**

AMPSAVER HALT

Der Ampsaver verhindert das Schleudern, bis der Strom, der von anderen Maschinen des Systems aufgenommen wird, unter einen spezifizierten Wert fällt. Die Fehlermeldung erlischt, sobald das Schleudern einsetzt. **ANMERKUNG:** Diese Fehlermeldung sollte nur dann auftreten, wenn die Maschine an ein Ampsaver-System angeschlossen ist.

MILTRENCH HALT

Miltrench verhindert das Entwässern der Maschine, bis andere Maschinen ihre Entwässerung beendet haben. Die Meldung erlischt bei Beginn des Schleuderns. **ANMERKUNG:** Diese Fehlermeldung sollte nur dann auftreten, wenn die Maschine an ein Miltrench-System angeschlossen ist.



**Section**  
**Nederlands**

**4**



## Geen symbool Noodstop

Deze grote rode knop in een geel vierkant kan zich op meerdere plaatsen op de machine bevinden. Hij heeft dezelfde functie als , maar blijft in ingedrukte stand staan en moet uitgetrokken worden en daardoor het circuit weer sluiten voordat het programma weer verder gaat.



### Stop knop

Indrukken van deze knop stopt direct het programma door het stuurstroom circuit te onderbreken. Noodstoppen hebben dezelfde functie. Trekkoorden en veiligheids-platen hebben, indien voorzien, ook dezelfde functie.



### start knop





Deze knop start een programma of laat een gekozen onderbroken programma weer verder gaan als aan bepaalde veiligheids voorwaarden is voldaan.

Hij wordt ook gebruikt tegelijk met andere knoppen, verder getoond in dit hoofdstuk.





### Deur Open knop

Deze knop ontgrendelt de deursluiting als de machine niet draait.

Drukken op  +  laat de trommel rechtsom draaien of linksom afhankelijk hoe  /  staat.



### Shake schakelaar

Deze schakelaar bepaalt de draairichting van de trommel als shaken is gekozen. Op  drukken, is rechtsom; op  drukken, is linksom.



### Balans afstelschakelaar lamp—ExN en balancerende verend opgehangen (Hydro-Cushion) modellen

Deze lamp gaat uit als de onbalans de limieten overschrijdt van het centrifugeren in de hoogste snelheid.





### Balans ventiel lamp— balancerende modellen.

Deze lampen tonen welke balansventielen open staan. Zij gaan uit als het balanceren afgelopen is, behalve bij wijzigingen in de balans en de onbalans hiermee compenseert. Als lampen meestal aanblijven tijdens het centrifugeren, kan dat betekenen dat de watertoevoer naar het balanssysteem niet goed is of dat het balanssysteem onderhoud nodig heeft.

Service is nodig als alle drie de lampen tegelijk oplichten.



### Handmatige schoonspoel schakelaar—machines met een vijf compartimenten zeepbak.

Houd deze schakelaar naar  om water in het eerste compartiment van de zeepbak te spuiten. Houd deze schakelaar naar  om de spuitkop te gebruiken voor het reinigen van de zeepbak.

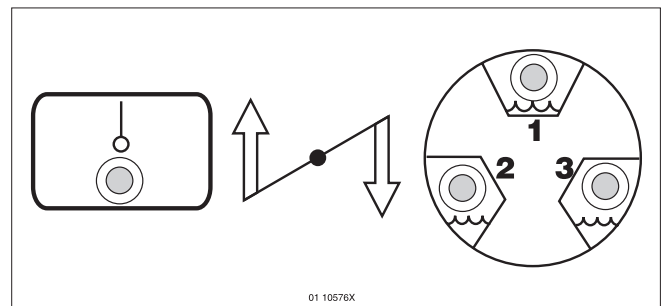



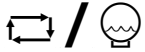
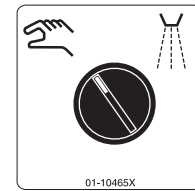
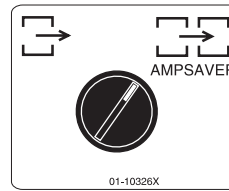

### Verzamelleiding Schoonspoel schakelaar

Druk op deze knop om de chemicaliën verzamelleiding met schoon water te spoelen.



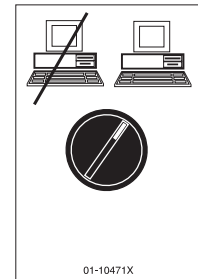
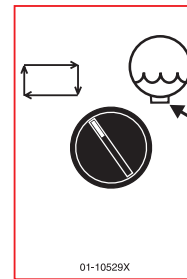
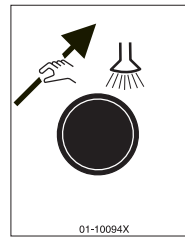

### Alternatieve uitlaat schakelaar

Zet deze schakelaar op  om alle machine functies uit te schakelen en de uitlaat dicht te laten. De machine kan uitgezet worden met de uitlaat dicht voor 's nachts inweken. Op  gezet, kan de machine normaal werken.





### Mildata netwerk/lokaal schakelaar—Mildata optie

Zet deze schakelaar op  om deze machine te laten communiceren met de Mildata computer. Zet deze op  om de eigen programma's te gebruiken.







### Ampsaver schakelaar— Ampsaver optie

 geeft de ampsaver de mogelijkheid om het centrifugeren uit te stellen indien noodzakelijk om te voorkomen dat het amperage door alle machines een vooraf ingesteld maximum overschrijdt.  voorkomt dat de ampsaver de machine werking kan beïnvloeden.







### Op/Neer kiep schakelaar—QTx, WTx en BTx modellen

Om de machine te laten kiepen, zet  /  voor de gewenste kiep richting, en houd dan  ingedrukt. Houd  ingedrukt om de machine in de normale positie te plaatsen.



### Hydraulische deur schakelaar—Modellen met gemotoriseerde deuren

Pressing  closes the door if a formula is not running.  opens the door if a formula is not running.

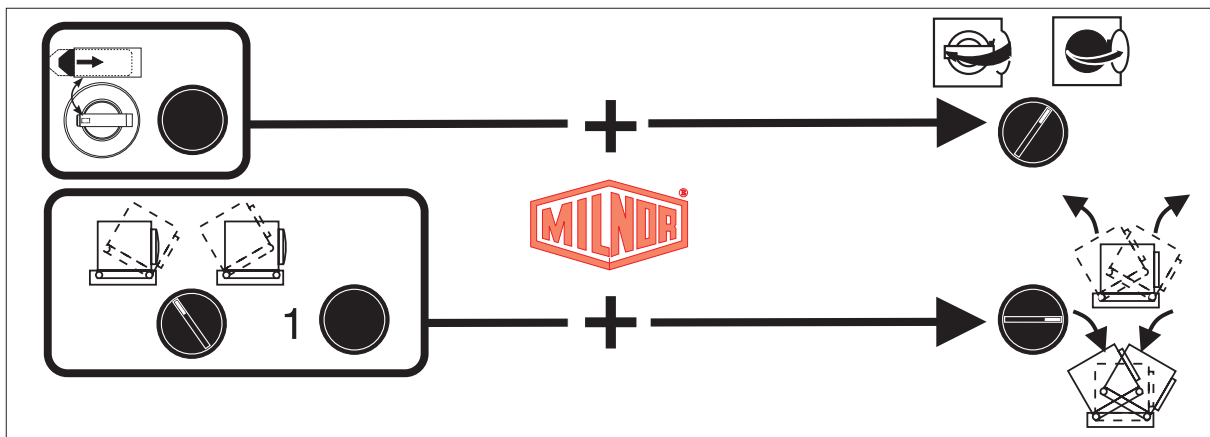

# Normale werking—Mark II, Voorover kiepende Centrifugerende Wasmachine

MSOUPLN0AH/9433AV

## Start de werkdag.

**Let op de veiligheid.** Volg alle veiligheids voorschriften in de handleiding en op deze machine op.

## Controleer switch posities.

Schakelaar  
symbool

Keuze

Schakelaar instelling bij Naam/Functie



Zet de Normaal bedrijf/Programmeer sleutel naar Normaal bedrijf.

**Zet spanning op de Microprocessor Besturing.** Zet de hoofdschelaar op aan (☺). Het signaal gaat aan en een serie van schermen verschijnt.

START WASPROGRAMMA  
00 OF OK SPANNI. WEG

De machine is klaar voor een lading.

REMOTE FORMULA 0000

Machine is on line met Mildata en klaar voor een lading. Zie “Geef post gegevens in als de machine on-line is met Mildata.”

**Geef post gegevens in als de machine on-line is met Mildata.**

De

machine vraagt om post gegevens. Geef een waarde in, en druk op **NEXT** bij iedere vraag.

Beeldscherm Boodschap	Toegestane waarden	Beschrijving
Geef programma in voor de machine	000-255	Was programma nummer
Geef EXTERN PROGRAMMA in	000-999	Was programma nummer
Geef W/ORDER in	000-999	Werk order nummer voor verrekening/vastlegging
Geef ontwaterings/centrifuge code in voor de machine	00-15	Ontwaterings/Centrifuge code voor deze lading
Geef droog code in voor de machine	00-15	Droog code voor deze lading
Geef doel in voor de machine	000-255	Shuttle ontlaad doel
Geef klant code in voor de machine	000-999	Klant code voor verrekening/vastlegging
Geef goederen code in voor de machine	000-999	Klant code voor verrekening/vastlegging
Geef stuks in voor de machine	000-999	Aantallen informatie voor verrekening/vastlegging
Geef vuil gewicht in voor de machine	00-99	Gewicht informatie voor verrekening/vastlegging
Geef post nummer in voor de machine	000-255	Post nummer voor verwerking
Geef laad grootte in voor de machine	0, 1	0 voor volle lading, 1 voor enkele lading om de droog code te bepalen
Geef werknemer nummer in	000-999	Werknemer nummer voor verrekening/vastlegging
Geef partij nummer in	000-999	Partij nummer voor verrekening/vastlegging

**Tabel A: Mogelijke Post Gegevens**

## Draai het wasprogramma.



### **GEVAAR: Explosie en Brand Gevaar**



Brandbare stoffen kunnen exploderen of vlam vatten in de trommel, uitlaat, goot of riool. De machine is ontworpen om te wassen met water, niet een andere oplossing. Het werken ermee kan goederen met een chemische oplossing opleveren met brandbare dampen.

- ☞ Gebruik geen brandbare oplossingen bij het wassen.
- ☞ Spoel grondig alle brandbare vuile goederen met meerdere koudwater baden voor een heet bad. Raadpleeg de lokale brandweer voorschriften en al uw verzekerings kantoren.

## Stel de lading samen.

1. Haal in de unoop geraaut linnen uit eluaar.
2. Maak de posten zo groot als ter plaatse bepaald wordt. Overbelading vermindert het was resultaat. Onderbelading kan de balans tijdens het centrifugeren verstoren.

## Laad de machine.

### Sluit de deur.

- Handbediende deur— Draai de deur dicht met voldoende kracht om hem in het slot te laten vallen.
- Automatische deur— Druk tegelijk de deur-open toets (🔓) en de hydraulische deur schakelaar in om te sluiten (🔒). Laat de schakelaar pas los als de deur vergrendeld is.
  - NOOT: Bij het sluiten van de deur gaat het alarm af als al eerder een programma gekozen is.



**Voeg zonodig chemicaliën toe.** Chemicaliën kunnen handmatig of automatisch toegediend worden, afhankelijk van de machine mogelijkheden en de gebruikte programma's. Er zijn de volgende mogelijkheden:

- Automatisch toedienen chemicaliën met een pomp of een centraal zeepdoseersysteem.
- Vul de zeepbak voor het starten van het programma. De zeep wordt dan automatisch met water ingespoten.
- Vul de zeepbak bij of spoel handmatig water in de zeepbak tijdens het programma, als er om gevraagd wordt.
- Giet de chemicaliën door de zeepbak voor of tijdens het programma.

Omdat de toedien methoden, programma's en te gebruiken chemicaliën bepaald worden in de industrie, worden de bedieningsprocedures in het bedrijf vastgesteld. Zie de handleiding voor verdere informatie van de optionele zeepbak, vloeibare zeep toediening en programma's.

**Kies een programma.** Als de machine is gekoppeld aan een Milda computer, zie "Invoeren Post Gegevens". De beschikbare programma's zijn afgedrukt in het Kies Programma Menu.

START WASPROGRAMMA  
00 OF OK SPANNI. WEG

Toets een programma nummer in (tweecijferig nummer van 01 tot en met 98) of loop door de beschikbare programma's door  of  in te toetsen. Zie de handleiding voor informatie over de standaard programma's 00 en 99.

START WASPROGRAMMA  
BESTAAT NIET

Verschijnt als een niet bestaand programma is gekozen.

**Start het programma.** Als het alarm signaal klinkt (deur dicht en programma kiezen), druk dan op de Start toets (①).

**Reageer op het einde van het programma.** Het alarmsignaal klinkt als het programma afgelopen is. Het kan ook klinken als tijdens het programma de aandacht van het bedieningspersoneel vereist is.

STOPPED  
PLEASE UNLOAD ME

Het programma is afgelopen.

XXXXXXXXX  
ONTLAAD UW MILNOR

Het "SHAKE"-programma—Indien nodig, open de deur, trek het wasgoed van de trommelwand, sluit de deur, Druk op ① en ga verder met draaien gedurende twee minuten. "HEEN EN WEER DRAAIEN" en "UITLAAT SNELHEID"—Druk op de Signaal-uit toets () om de trommel te stoppen en maak het programma af.



**GEVAAR: Vastloop / Verstrik en Afbreek Gevaar**



Kontakt met te verwerken goederen kunnen de goederen om uw lichaam en ledematen draaien en u uiteen rijten / uitschakelen. De goederen zijn normaal gesproken afgeschermd door een gesloten trommel deur.

 Probeer niet de deur te openen of in de trommel te reiken voordat de trommel gestopt is.



**GEVAAR: Schroei / Brand Gevaar**



Kontakt met heet sop/waswater kan brandwonden veroorzaken. Waswater kan langs de deur komen of uit gaten van de trommel spuiten.

 Niet de trommel deur openen met water in de trommel.



**GEVAAR: Stoot en Verpletter Gevaar**



Machines met automatische deur—De bewegende deur kan u raken en uw ledematen verpletteren of afklemmen als u tussen de deur en de machine komt. Sommige deuren bewegen automatisch.

 Houdt uzelf en ieder ander weg bij verplaats gebieden en paden.



 Gebruik de machine niet met een niet funktionerende twee-handen besturing.

**Open de deur.** Beveiligingen voorkomen dat een deur geopend kan worden tijdens een programma in werking en direct na het handmatig afbreken van een programma.









 **GEVAAR: Verpletter Gevaar**



**Alleen Kiepende machines—De machine kan uw lichaam of ledematen verpletteren als u beklemd raakt tussen de buiten trommel en het frame. Sommige machines kiepen automatisch.**

-  **Houdt uzelf en ieder ander weg bij verplaats gebieden en paden.**
-  **Houdt beide handen op de besturing schakelaar tijdens het bedienen.**
-  **Gebruik de machine niet met een niet funktionerende twee-handen besturing.**



**Kiep voorover om te lossen.** Plaats de waswagen of ander los apparaat onder de deur, kiep als volgt:

- De modellen 48032BTx, 48036QTx, 52038WTx, 72044WTx—Zet de Achter-Voor Kiep schakelaar ( / ) naar Achter (). Druk tegelijk de Start toets (①) in en zet de Omhoog/Omlaag Kiep schakelaar ( / ) naar Omhoog (). Houdt beide vast tot de machine de gewenste hoek of zijn uiterste stand heeft bereikt.
- De Modellen 64046E6N, 72046E5N—Druk tegelijk de Start toets (①) in en zet de Omhoog/Omlaag Kiep schakelaar ( / ) naar Omhoog (). Houdt beide vast tot de gewenste hoek is bereikt of de machine zijn uiterste stand heeft bereikt.



 **GEVAAR: Vastloop / Verstrik en Afbreek Gevaar**



**Kontakt met te verwerken goederen kunnen de goederen om uw lichaam en ledematen draaien en u uiteen rijten / uitschakelen.**

-  **Alleen open eind machines—Niet tegelijkertijd shaken en goederen eruit trekken.**
-  **Houdt uzelf en ieder ander weg bij verplaats gebieden en paden.**
-  **Gebruik de machine niet met een niet funktionerende twee-handen besturing.**

**Shaken om de lading te lossen.**

1. Druk tegelijk de Start toets (①) en de links-/rechtsom schakelaar ( of ) in. De trommel draait tot de knoppen worden losgelaten.
2. Wissel van draairichting en draai nogmaals, indien nodig.

**Ga terug naar horizontale positie vanuit voorover kiepen.** Druk tegelijk de Start toets (①) in en zet de Omhoog/Omlaag Kiep schakelaar ( / ) naar Omlaag (). Houdt beide vast tot de machine in horizontale positie is.

## Scherm normale bediening

Als de deur gesloten is, zullen soortgelijke normale werk schermen als onderstaand verschijnen.

Niveau niet voldoende; geen chemicalin toegevoegd:	10:38 F0005S03 02:37 dF=A093/D140 * HC3	wisselt af met	10:38 STEP 03 02:37 WAIT FOR LEVEL 2 HC3
Niveau voldoende; geen chemicalin toegevoegd:	10:38 F0005S03 02:37 dF=A093/D140 LEV1	wisselt af met	10:38 STEP 03 02:37 dF=A093/D140 SPD 0
Chemicalin toegevoegd of signaal gegeven:	10:38 F0005S03 02:37 02-04 SOAP+ALKALI	wisselt af met	10:38 STEP 03 02:37 02-04 SOAP+ALKALI
Uitlaten:	DRAINING TO SEWER 01:20 20RPM		
Centrifugeren:	05:30 F0005S06 05:30 LO SPD EXT 0450 RPM	wisselt af met	05:30 EXTRACT 05:30 LO SPD EXT 0450 RPM

Gegevens	Wat het betekent	Gegevens	Wat het betekent
<b>OF Programma stappen</b>			
10:38	Overgebleven programma tijd	STEP 03	Stap naam
F000	Programma nummer	WAIT FOR LEVEL 2	Wachten op het geprogrammeerd niveau
S03	Stap nummer	WAIT FOR LEV 10"	Elektronische niveau sensor wacht tot 10 inches/duim (of cm)
02:37	Overgebleven stap tijd	W=A00125/D00135	Gemeten water: A=bereikt, D=geprogrammeerd
dF/dC	Bad temperatuur (°F/°C) indien temp sondes geïnstalleerd; A=bereikt, D=geprogrammeerd	SPD 0	Als snelheid programmeerbaar is: 0=laag, 1=hoog. Toont toerental voor machines met variabele snelheid.
*	Niveau bereikt: * (onder laag), 1, 2, 3	02-04	Chemicalin nummer en naam nummer (alternatief voor meerdere chemicalin)
HC3	Water ventielen aan: warm, koud, 2e, 3e	SOAP+ALKALI	Chemicalin naam (alternatief voor meerdere chemicalin)
<b>Uitlaat/Centrifugeer stappen</b>			
01:20	Overgebleven uitlaat tijd	LO SPD EXT	Centrifugeer snelheid (toont HI voor enkele snelheid)
20RPM	Huidige snelheid als ingesteld voor toerental registratie en variabele snelheid		

# Oplossen Storingen—Mark II Centrifugerende Wasmachine

MSOUPUTSAH/9436AV

## Onderbrekingen te Repareren door de Bedienings

**medewerker**—Deze storingen kunnen normaal gesproken opgelost worden via het bedienings paneel.

THREE WIRE DISABLED  
any message

Het stuurstroom relais, dat de spanning regelt naar de besturing van de machine, was uitgezet of de spanning van de machine was weer aangegaan na het uitzetten of na het uitvallen van de stroom.

HERSTEL: Druk op ① om het stuurstroom circuit te activeren. Als het stuurstroom circuit niet geactiveerd kan worden of er verschijnt een andere boodschap op het scherm, vraag dan om servicedienst.

ACCUM. DATA ERROR  
NEXT TO CLEAR DATA

De gegevens van de accumulator zijn onbetrouwbaar

HERSTEL: Druk op **NEXT** om de accumulator gegevens te wissen en weer op te starten.

LOST WATER DATA  
NEXT TO PROCEED

De gegevens betreffende het water zijn onbetrouwbaar.

HERSTEL: Druk op **NEXT** zodat de besturing om informatie vraagt. De machine start weer op.  
NOOT: Als de machine geen water dosering, vraag dan assistentie van de leiding om te zorgen dat de configuratie waarden overeenkomen met de apparatuur.

MANUAL EXTRACT :  
MUST HAVE LEVEL 2

Niveau 2 werd niet bereikt voor dat handmatig centrifugeren opgestart werd.

HERSTEL: Geef handmatig het niveau 2 commando. Neem de tijd om dit niveau te bereiken, centrifugeer handmatig. Ga verder op handbediening. Druk op  om weer te starten.

## Onderbrekingen die Ingrijpen door de Leiding

**vereisen**—Om deze storingen op te lossen, moet meestal in de programmagegevens en de procedures in de handleiding gekeken worden.

CLEAR MEMORY NOW  
PRESS 4 + 5 + 6

Programmagegevens waren niet compleet meer.

HERSTEL: Vraag de leiding om assistentie om het geheugen te wissen en de machine opnieuw te programmeren. Ga terug naar de in bedrijf stand om weer te starten.

CONFIG ERROR  
TURN KEY TO PROGRAM

Configuratie gegevens waren niet compleet meer.

HERSTEL: Vraag de leiding om assistentie om de machine opnieuw te configureren. Ga terug naar de in bedrijf stand om weer te starten.



name FAILED  
CHECK THIS BOARD

Er is een printkaart defekt of verwijderd.

HERSTEL: Druk op **ESCAPE**. Vraag de leiding om assistentie om te controleren of de configuratie waarden overeenstemmen met de apparatuur. Als de melding terugkomt, vraag dan om de servicedienst.

INVALID PASSWORD

Tijdens een handmatige onderbreking was een ongeldig wachtwoord ingetoetst.

HERSTEL: Toets een geldig wachtwoord in.

INVALID WORK ORDER

Het werk order nummer zit niet in het Mildata geheugen.

HERSTEL: Toets een geldig nummer in.

INVALID GOODS CODE

De goederen code zit niet in het Mildata geheugen.

HERSTEL: Toets een geldig nummer in.

INVALID CUST CODE

De klantcode zit niet in het Mildata geheugen.

HERSTEL: Toets een geldig nummer in.

INVALID EMPLOYEE #

Het medewerkers nummer zit niet in het Mildata geheugen.

HERSTEL: Toets een geldig nummer in.

INVALID FORMULA

Het programma nummer zit niet in het Mildata geheugen.

HERSTEL: Toets een geldig nummer in.

INVALID FORM DATA

De van Mildata ontvangen programma gegevens zijn niet korrekt.

HERSTEL: Vraag de leiding om assistentie om de programma gegevens te controleren in Mildata.

DATA UNLOCATABLE

Mildata kon de programma gegevens van de gevraagde machine niet vinden.

HERSTEL: Vraag de leiding om assistentie om te controleren of de machine juist geconfigureerd is in Mildata.

**Onderbrekingen die De Servicedienst vereisen**— D e z e storingen hebben meestal betrekking op mechanische of elektrische onderdelen. Vraag om de servicedienst in overeenstemming met de gepubliceerde veiligheids informatie. Zie de handleiding Veiligheid.

\*-KEY PAD ERROR-\*  
key name

Een toets van het toetsenbord zat vast of maakte kortsluiting.

HERSTEL: Vraag de servicedienst.

BRAKE FAULT, MUST BE  
CLEARED TO RESTART

De remdruk schakelaar detecteerde een te lage luchtdruk, in de lucht cilinder die de remmen los moet maken, om te kunnen garanderen dat de remmen los zijn.

HERSTEL: Vraag de servicedienst. De melding verdwijnt als de remdruk beveiliging weer voldoende luchtdruk meet.

normal run message  
CHECK LEVEL SWITCH

De niveau schakelaar heeft niet gewerkt.

HERSTEL: Vraag de servicedienst.

normal run message  
CHECK type PROBE

De stoom of water temperatuur voeler had storing.

HERSTEL: Vraag de servicedienst.

SPEED SWITCH OPEN

Het toerental schakelaar circuit is onderbroken.

HERSTEL: Als de trommel stilstaat, vraag dan om de servicedienst. De melding verdwijnt als het circuit sluit.

normal run message  
RECYCLE FAILURE

De machine begon vijf maal opnieuw in een enkele centrifuge stap. De machine tracht de lading te balanceren door de voorgaande stap te herhalen.

HERSTEL: Als de melding terugkomt, vraag dan om de servicedienst.

normal run message  
TOO LONG TO COOL

De ingestelde afkoeltijd was overschreden.

HERSTEL: Vraag om de servicedienst om het afkoelsysteem te controleren De melding verdwijnt als de afkoel temperatuur is bereikt.

normal run message  
TOO LONG TO FILL

De ingestelde vultijd was overschreden.

**HERSTEL:** Vraag om de servicedienst om het water toevoer systeem te controleren. De melding verdwijnt als de machine weer op niveau is.

normal run message  
TOO LONG TO STEAM

De ingestelde tijd om de gewenste stoom temperatuur te bereiken was overschreden.

**HERSTEL:** Vraag om de servicedienst om het stoomsysteem te controleren. De melding verdwijnt als de temperatuur is bereikt.

## Onderbrekingen die vanzelf herstellen

AMPSAVER HALT

De ampsaver houdt het centrifugeren tegen tot het amperage in het systeem onder een ingesteld niveau is. De melding verdwijnt als het centrifugeren begint. **NOOT:** Deze melding zou alleen moeten kunnen verschijnen als de machine aangesloten is op een Ampsaver systeem.

MILTRENCH HALT

Miltrench houdt het uitlaten van deze machine tegen tot andere machines klaar zijn met uitlaten. De melding verdwijnt als het uitlaten begint. **NOOT:** Deze melding zou alleen moeten kunnen verschijnen als de machine aangesloten is op een Miltrench systeem.



**Section**  
**Italiano**

**5**

# Descrizione dei Controlli—Mark II, Lavacentrifuga Ribaltabile Per Scaricare

MSOUPLECTAI/9433AV



## Interruttore principale

Questo interruttore controlla la potenza del circuito di controllo monofase della macchina e l'alimentazione elettrica DC del microprocessore e dei suoi componenti. Premendo  durante il funzionamento blocca la macchina.







## Segnalatore Acustico per l'Operatore

Questo segnalatore si attiva quando è richiesto l'intervento dell'operatore, come per esempio quando è necessario scaricare o quando si verificano determinati errori. Premendo  il segnalatore si spegne.





## Pulsante Annullamento Segnalatore Acustico

Questo pulsante estingue il segnale acustico per l'operatore (). Se il segnale era stato programmato come parte di una formula, la formula riprende dopo che questopulsante è stato premuto. Se causato per errore per illuminare , premendo  dopo aver corretto l'errore estinguerà la segnalazione acustica. Se  era illuminato quando era stata selezionata una formula valida, la segnalazione terminerà automaticamente quando la formula è cominciata o la porta è aperta.



## Interruttore a chiave Avvio/Programma

Posizionando l'interruttore a chiave su  impedisce che i dati programmati possano essere modificati e permette un funzionamento normale della macchina. Posizionando l'interruttore a chiave su  è possibile un funzionamento programmabile della macchina e alcune procedure di riparazione.

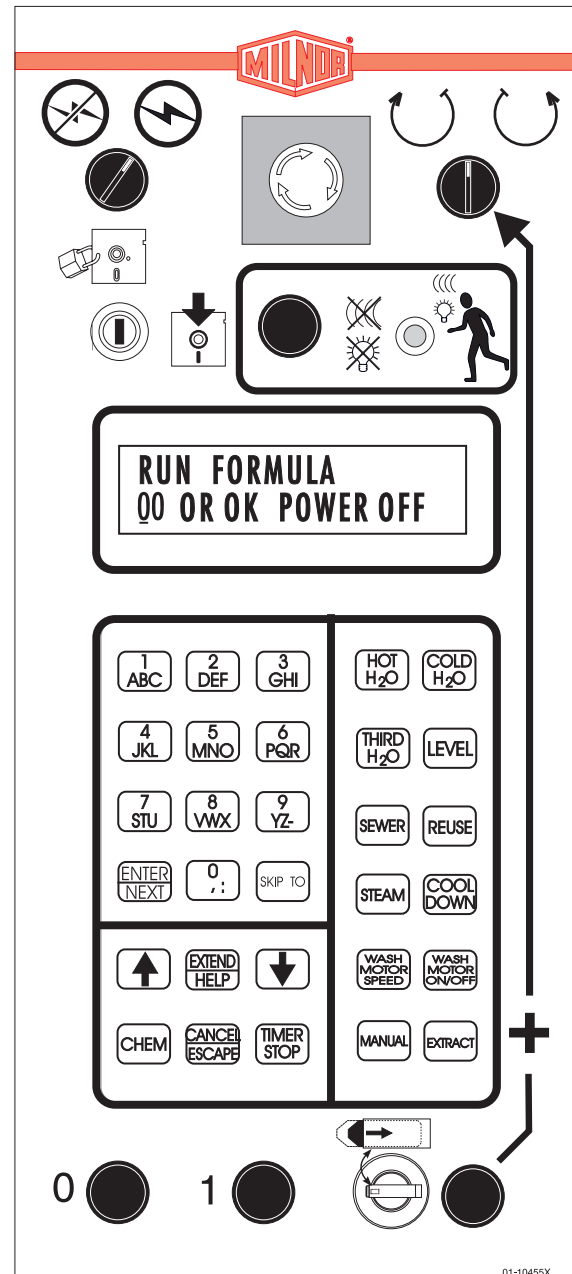

### **Nessun simbolo Pulsante Blocco Di Emergenza (Emergency Stop)**

Questo grande pulsante rosso in un rettangolo giallo può trovarsi in diversi punti della macchina. Ha le stesse funzioni di ①, ma racchiude la posizione pressata e deve essere girato per liberare il pulsante e chiudere il circuito prima che il funzionamento possa riprendere.

①

### **Pulsante Stop**

Questo pulsante blocca immediatamente la macchina aprendo il "circuito a tre fili". I pulsanti dell'Emergency Stop svolgono le stesse funzioni. Anche le corde di trazione e le piastre a scatto, se la macchina ne è dotata, hanno questa funzione.

①

### **Pulsante Avvio (Start)**



Questo pulsante dà il via a un ciclo o riprende un ciclo interrotto se una formula è stata selezionata ed esistono determinate condizioni di sicurezza.

E' utilizzato anche con altri comandi elencati in questa sezione.





### **Pulsante Apertura Porta (Door Open)**

Questo pulsante ritrae il pistone della porta per aprire la porta se la macchina non è in funzione.

Premendo ① +  il cilindro ruota a intermittenza in senso orario o in senso antiorario posizionato su  / .



### **Interruttore Rotazione**

Questo pulsante determina la direzione in cui il cilindro ruoterà quando viene dato il comando di jogging. Premendo  ruota in senso orario; premendo  ruota in senso antiorario.

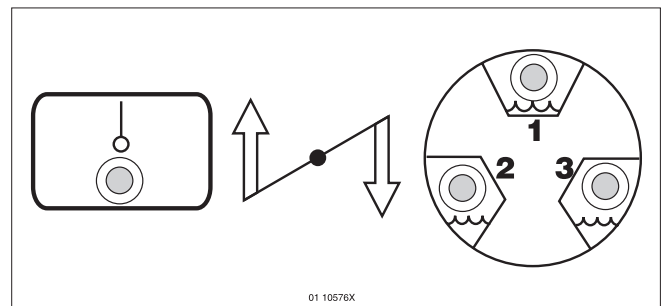

### **Spia luminosa— Rilevazione Bilanciamento Modelli ExN e modelli a bilanciamento Hydro-Cushion®**

Questa spia luminosa si spegne quando lo sbilanciamento supera i limiti della centrifuga ad alta velocità.





### **Spie luminose— Valvola di Bilanciamento modelli a bilanciamento**

Queste spie mostrano quali valvole di bilanciamento sono aperte. Si spengono quando il bilanciamento è completo, tranne che per il funzionamento a intermittenza, poiché il sistema di bilanciamento compensa le variazioni nello sbilanciamento. Le spie che rimangono accese durante la maggior parte delle centrifughe potrebbero stare a indicare un rifornimento d'acqua inadeguato al sistema di bilanciamento o che il sistema di bilanciamento necessita di assistenza.

La manutenzione è necessaria se tutte e tre le spie si accendono contemporaneamente.



### Interruttore— Manuale Flusso/Irrorazione, macchine con iniettori di alimentazione a cinque compartimenti

Posizionate questo interruttore su  per far scorrere l'acqua nel primo compartimento dell'iniettore di alimentazione. Tenete questo interruttore su  per utilizzare il polverizzatore per pulire l'iniettore di alimentazione.

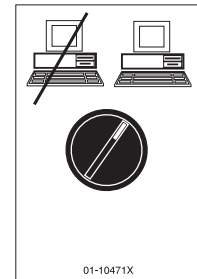
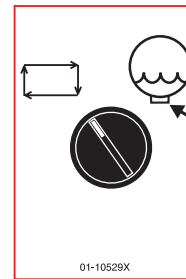
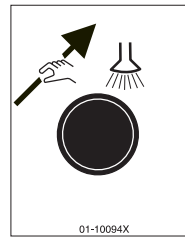
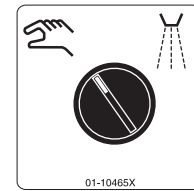
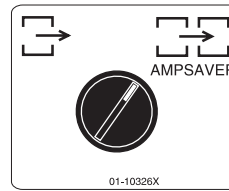

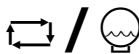

### Pulsante Lavaggio Collettore (Manifold Flush)

Premete questo pulsante per lavare abbondantemente il collettore di alimentazione di prodotti chimici con acqua di rete.





### Interruttore Scarico Alternato

Posizionate questo interruttore su  per disattivare tutte le funzioni della macchina e tenere chiuso il tubo di scarico. La macchina può essere disattivata con il tubo di scarico chiuso per l'ammollo notturno. Posizionate su  per permettere un funzionamento normale.





### Interruttore— Mildata A Distanza/Locale, opzione Mildata

Posizionate questo interruttore su  per far in modo che la macchina colloqui con il computer Mildata. Posizionate su  per utilizzare le formule interne alla macchina.









### Interruttore— Ampsaver, opzione Ampsaver

 fa sì che il dispositivo di controllo Ampsaver ritardi la centrifuga quando è necessario per evitare l'ampereaggio provocato da tutte le macchine quando superano un limite massimo preselezionato.  impedisce che il dispositivo di controllo Ampsaver influisca sul funzionamento della macchina.







### Interruttore— Ribaltamento In Alto/In Basso Modelli QTx, WTx e BTx

Per ribaltare la macchina, posizionate  /  sulla direzione di ribaltamento desiderata, poi tenete premuto  + . Tenete premuto  +  per riportare il cilindro in posizione normale.



### Interruttore— Porta Idraulica Modelli con porte motorizzate

Premendo  +  si chiude la porta se una formula non è in funzione.  +  apre la porta se la formula non è in funzione.



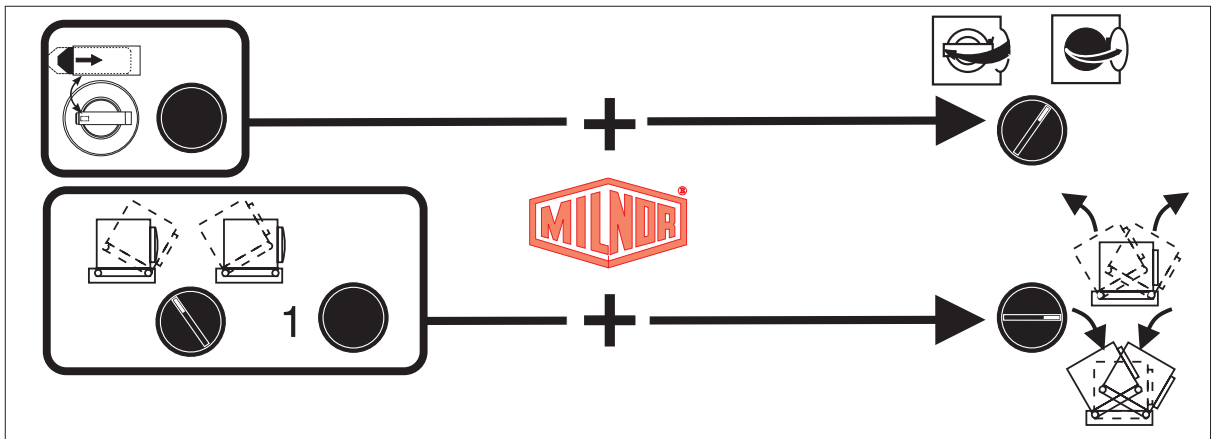

# Funzionamento Normale—Mark II, Lavacentrifuga Ribaltabile Per Scaricare

MSOUPLN0AI/9433AV

## Iniziate il procedimento di lavoro giornaliero

**Attenzione alla sicurezza.** Attenetevi a tutte le istruzioni di sicurezza contenute nel manuale e poste sulla macchina.

### Controllate La Posizione Degli Interruttori.

Simbolo Interruttore	Selezione	Posizionamento interruttore secondo Nome/Funzione
-------------------------	-----------	---



Mettete in funzione l'interruttore a chiave Run/Program.

**Attivate il Dispositivo di Controllo del Microprocessore.** Posizionate su  l'interruttore Master. Il segnalatore acustico per l'operatore suona e compaiono una serie di display.

AZIONAMENT FORMULA  
00 OR OK POWER OFF

La macchina è pronta per un carico.

FORMU A DISTAN 0000

La macchina è collegata direttamente a Mildata e pronta per un carico. Consultare “Inserite i Dati Relativi alla Pizza se la Macchina è Direttamente Collegata con Mildata.”

**Inserite i Dati Relativi alla Pizza se la Macchina è Direttamente Collegata con Mildata.** La macchina richiede i dati relativi alla pizza. Inserite un numero e premete **NEXT** per ogni richiesta.

Messaggio sul Display	Valore valido	Descrizione
inserimento FORMULA nella la macchina	000-255	Numero formula lavaggio
inserite FORMULA REMOTA	000-999	Numero formula lavaggio
inserite W/ORDER	000-999	Numero di consegna lavoro per la contabilità
Inserite codice centrifuga nella macchina	00-15	Codice centrifuga per tale carico
inserite codice asciugatura nella macchina	00-15	Codice asciugatura per tale carico
Inserite destinazione nella macchina	000-255	Destinazione di scarico della navetta
inserite codice cliente nella macchina	000-999	Codice cliente per la contabilità
inserite codice biancheria nella macchina	000-999	Codice cliente per la contabilità
inserite pezzi nella macchina	000-999	Informazioni sulla quantità per la contabilità
inserite peso biancheria sporca nella macchina	00-99	Informazioni sul peso per la contabilità
Inserite numero pizza nella macchina	000-255	Numero pizza per il trattamento
Inserite misura carico nella macchina	0, 1	0 per carico pieno, 1 per carico parziale per determinare il codice di asciugatura
inserite codice impiegato	000-999	Codice impiegato per la contabilità
Inserite numero lotto	000-999	Numero lotto per la contabilità

**Tavola A: Possibili Dati Pizza**

## Far partire il ciclo di lavaggio.

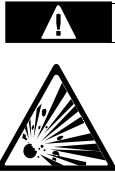

### **PERICOLO: Rischi di Esplosione e di Incendio**

Sostanze infiammabili possono esplodere o prendere fuoco nel cesto, nello scolo o nel tubo di scarico. Il macchinario è progettato per lavare con acqua non con altri solventi. Il trattamento può far sì che la biancheria contenente solventi emani vapori infiammabili.

☞ Non utilizzate solventi infiammabili nel trattamento.

☞ Lavate abbondantemente e in modo accurato la biancheria macchiata infiammabile con vari bagni freddi prima di qualsiasi bagno bollente. Consultatevi con l'ufficio per la prevenzione contro gli incendi/ufficio di pubblica sicurezza e qualsiasi compagnia di assicurazione.

## Preparate il carico.

1. Separate la biancheria ingarbugliata.
2. Misurate i carichi come determinati localmente. Il sovraccarico potrebbe ridurre la qualità di lavaggio. Un carico ridotto potrebbe inibire la capacità di centrifugazione.

## Caricate la macchina.

### Chiudete lo sportello.

- Sportello manuale— Fate rotare lo sportello chiuso con sufficiente forza da bloccarlo con il chiavistello.
- Sportello a funzionamento elettrico— Per chiudere tenete premuto contemporaneamente il pulsante (🔌) Door Open e l'interruttore Hydraulic Door (🔌). Continuate a tenere premuto finché lo sportello non si chiude col chiavistello.
- **IMPORTANTE:** La chiusura dello sportello mette in funzione il segnalatore acustico per l'operatore se in precedenza era stata selezionata una formula.



**Aggiungete prodotti chimici se necessario.** I rifornimenti di prodotti chimici possono essere effettuati manualmente o automaticamente, a secondo dell'hardware opzionale fornito e delle formule utilizzate.

- Introducete automaticamente i prodotti chimici attraverso un dispositivo di pompaggio per sostanze chimiche o un sistema di rifornimento liquido centrale.
- Caricate il meccanismo di immissione rifornimento prima di avviare il ciclo. I rifornimenti vengono fatti scorrere automaticamente.
- Ricaricate i compartimenti del meccanismo di immissione rifornimento o fate scorrere manualmente il contenuto del compartimento 1 durante il ciclo, quando richiesto dalla formula.
- Versate i rifornimenti attraverso lo scivolo del detersivo prima o durante il ciclo.

Poiché il metodo di immissione, le formule, e i prodotti chimici da utilizzare vengono stabiliti sul campo, le procedure dell'operatore nell'aggiunta di prodotti chimici vengono decise localmente. Per maggiori informazioni sul meccanismo di rifornimento opzionale, immissione di rifornimento liquido e formule, consultate il manuale di riferimento.

**Selezionate una formula.** Se la macchina è direttamente collegata con un computer Milda, consultate "Inserimento Dati Pizza." Le formule disponibili sono elencate nel menu Run Formula.

AZIONAMENT FORMULA  
00 OR OK POWER OFF

Inserite il numero di una formula (due numeri digitali da 01 a 98) o elencate le formule disponibili premendo  o . Consultate il manuale di riferimento per informazioni sulle formule permanenti 00 e 99.

AZIONAMENT FORMULA  
DOES NOT EXIST

Compare se viene selezionata una formula non esistente.



**Date inizio al ciclo.** Quando si accende il segnalatore acustico per l'operatore (lo sportello è stato chiuso e la formula selezionata), premete il pulsante  (Start).

**Agite alla fine del ciclo.** Il segnalatore acustico per l'operatore si metterà in funzione quando il ciclo termina. Potrebbe anche suonare durante il ciclo qualora fosse necessario l'intervento dell'operatore. Controllate sul display.

XXXXXXXXX  
SCARICARE MILNOR

Il ciclo è completato.

XXXXXXXXX  
SCARICARE MILNOR

"TUMBLING"—Se necessario, aprite lo sportello, tirate giù la biancheria, chiudete lo sportello, poi premete il pulsante  (Start) per continuare il "tumbling" per due minuti. "REVERSING" o "DRAIN PEED"—Premete il pulsante  (Signal Cancel) per bloccare il movimento del cilindro e completare il ciclo.



**PERICOLO: Rischi di Intrappolamento e di Ferimento**



Il contatto con la biancheria sottoposta a trattamento può far sì che questa si avvolga intorno al vostro corpo o ai vostri arti provocando lacerazioni profonde. La biancheria è in genere isolata tramite lo sportello chiuso del cesto.

 Non tentate di aprire la porta o di infilarvi nel cesto finché quest'ultimo non sia completamente fermo.



**AVVERTENZA: Rischi di Scottature**



Il contatto con un liquido bagno bollente può ustionarvi. Il liquido bagno può fuoriuscire dallo sportello o venir spruzzato fuori dai fori del cesto.

 Non aprire lo sportello del cesto quando dentro il cesto c'è l'acqua.



**PERICOLO: Rischi di Urto e Schiacciamento**



Macchinari con sportello a funzionamento elettrico— Lo sportello in movimento vi può colpire o schiacciare o può comprimere i vostri arti se questi rimangono intrappolati tra lo sportello e la macchina. Alcuni sportelli si muovono automaticamente.

 Tenete voi stessi e gli altri lontani dalle aree e traiettorie di movimento.



 Non mettete in funzione la macchina con i dispositivi di comando manuali a due mani non perfettamente funzionanti.

**Aprite lo sportello.** Delle protezioni impediscono che lo sportello si apra mentre è in corso una formula e immediatamente dopo che una formula è stata portata a termine manualmente.











 **PERICOLO: Rischi Derivanti da Schiacciamento**



Solo macchine ribaltabili—Il macchinario può schiacciare il vostro corpo o i vostri arti se rimanete intrappolati tra lo alloggiamento ribaltabile e un'oggetto fisso. Alcune macchine si ribaltano automaticamente.

-  Tenete voi stessi e gli altri lontani dalle aree e traiettorie di movimento.
-  Tenete entrambe le mani sui dispositivi di comando mentre operate.
-  Non mettete in funzione la macchina con i dispositivi di comando manuali a due mani non perfettamente funzionanti.



**Ribaltate in avanti per scaricare.** Posizionate sotto lo sportello il carrello o altri dispositivi atti a ricevere la biancheria, poi ribaltate nel seguente modo:

- Modelli 48032BTx, 48036QTx, 52038WTx, 72044WTx—Posizionate l'interruttore  /  (Rear/Front Tilt) su  (Rear). Contemporaneamente tenete premuto il pulsante  (Start) e collocate l'interruttore  /  (Up/Down Tilt) su  (up). Mantenete queste posizioni finché non si raggiunge l'angolo di inclinazione desiderato o finché la macchina non si ferma al suo punto di ribaltamento massimo in avanti.
- Modelli 64046E6N, 72046E5N—Contemporaneamente tenete premuto il pulsante  (Start) e posizionate l'interruttore  /  (Up/Down Tilt) su  (up). Mantenete queste posizioni finché non si raggiunge l'angolo di inclinazione desiderato o fin quando la macchina non si ferma al suo punto di ribaltamento massimo in avanti.



 **PERICOLO: Rischi di Intrappolamento e di Ferimento**







Il contatto con la biancheria durante il trattamento può far sì che questa si avvolga intorno al vostro corpo o ai vostri arti provocando ferite profonde.

-  Solo macchine a cesto aperto— Non far funzionare a intermittenza il cesto e contemporaneamente tirare fuori gli indumenti.
-  Tenete voi stessi e gli altri lontani dalle aree e traiettorie di movimento.
-  Non mettete in funzione la macchina con i dispositivi di comando manuali a due mani non perfettamente funzionanti.

**Fate ruotare il cilindro a intermittenza per scaricare la biancheria.**

1. Tenete premuti contemporaneamente il pulsante  (Start) e l'interruttore Jog ( o ). Il cilindro ruota finché i pulsanti non vengono rilasciati.
2. Se necessario, cambiate la direzione di rotazione e fate ruotare di nuovo.

**Riportate la macchina dalla posizione di ribaltamento in avanti alla posizione di non-ribaltamento.** Contemporaneamente tenete premuto il pulsante  (Start) e posizionate l'interruttore  /  (Up/Down Tilt) su  (down). Mantenete queste posizioni finché la macchina raggiunge la sua posizione di non-ribaltamento.

## Normale Funzionamento Del Monitor

Quando lo sportello è chiuso appariranno dei display a funzionamento normale simili a quelli sottostanti .

Livello non soddisfatto; nessuna sostanza chimica messa in azione:	10:38 F0005S03 02:37 dF=A093/D140 * HC3	si alterna con	10:38 STEP 03 02:37 WAIT FOR LEVEL 2 HC3
Livello soddisfatto; nessuna sostanza chimica messa in azione:	10:38 F0005S03 02:37 dF=A093/D140 LEV1	si alterna con	10:38 STEP 03 02:37 dF=A093/D140 SPD 0
Sostanze chimiche o segnale messi in moto:	10:38 F0005S03 02:37 02-04 SOAP+ALKALI	si alterna con	10:38 STEP 03 02:37 02-04 SOAP+ALKALI
Scarico:	DRAINING TO SEWER 01:20 20RPM		
Centrifugazione:	05:30 F0005S06 05:30 LO SPD EXT 0450 RPM	si alterna con	05:30 EXTRACT 05:30 LO SPD EXT 0450 RPM

Sistema Dati	Il suo Significato	Sistema Dati	Il suo Significato
<b>Fasi Bagno</b>			
10:38	Tempo residuo della formula	STEP 03	Nome fase
F000	Numero formula	WAIT FOR LEVEL 2	Attesa livello richiesto
S03	Numero fase	WAIT FOR LEV 10"	Sensore elettronico di livello in attesa di 10 pollici (o centimetri)
02:37	Tempo residuo fase	W=A00125/D00135	Dosaggio acqua: A=raggiunto, D=richiesto
dF/dC	Temperatura bagno (°F/°C) Se le misurazioni della temperatura sono configurate; A=raggiunta, D=richiesta	SPD 0	Se la velocità è programmabile: 0=bassa, 1=alta. RPM compare nei macchinari con velocità variabile.
*	Livello raggiunto: * (sotto basso), 1, 2, 3	02-04	Numero prodotto chimico e numero del nome (si alternano nelle sostanze chimiche multiple)
HC3	Valvole dell'acqua aperte: Bollente, Fredda, Seconda, terza	SOAP+ALKALI	Nome prodotto chimico (si alterna nelle sostanze chimiche multiple)
<b>Scarico/Fasi Centrifuga</b>			
01:20	Tempo residuo scarico	LO SPD EXT	Velocità di centrifuga (compare HI per velocità unica)
20RPM	Velocità effettiva se configurata per il sensore RPM e velocità variabile		

# Correzione Errori—Mark II Lavacentrifuga

MSOUPUTSAI/9436AV

**Interruzioni Correggibili dall'Operatore**—Questi errori possono essere generalmente corretti dal dispositivo dei comandi per l'operatore.

THREE WIRE DISABLED  
any message

Il relè del circuito a tre fili che fornisce energia del circuito di controllo alla macchina è stato disattivato o l'energia è stata ripristinata nella macchina dopo un arresto o una perdita di energia.

**RIPRISTINAMENTO:** Premete ① per chiudere il circuito a tre fili. Se il circuito a tre fili rimane disattivato o sul display appare un altro messaggio, richiedete l'intervento di assistenza autorizzata.

ACCUM. DATA ERROR  
NEXT TO CLEAR DATA

I dati relativi all'accumulatore sono inattendibili.

**RIPRISTINAMENTO:** Premete **NEXT** per azzerare i dati relativi all'accumulatore e riprendere il funzionamento.

LOST WATER DATA  
NEXT TO PROCEED

I dati relativi all'acqua sono inattendibili.

**RIPRISTINAMENTO:** Premete **NEXT** cosicchè il dispositivo di controllo solleciti le informazioni. La macchina riprende il funzionamento. **ATTENZIONE:** Se la macchina non ha acqua regolata, richiedete l'intervento di personale dirigente per assicurarvi che i valori di configurazione si adattino all'attrezzatura.

MANUAL EXTRACT :  
MUST HAVE LEVEL 2

Il livello non è stato raggiunto prima che sia stato dato manualmente il comando di centrifuga.

**RIPRISTINAMENTO:** Date manualmente il comando di livello 2. Attendete di raggiungere questo livello, poi date manualmente il comando di centrifuga. Continuate con il funzionamento manuale. Premete ✂ per riprendere il funzionamento.

## Interruzioni che Richiedono L'intervento Di Personale Dirigente.

—Questi errori richiedono, in genere, l'accesso ai dati del programma e alle procedure incluse nel manuale di riferimento.

CLEAR MEMORY NOW  
PRESS 4 + 5 + 6

I dati del programma sono stati alterati.

**RIPRISTINAMENTO:** Richiedete l'assistenza di personale dirigente per cancellare la memoria e riprogrammare la macchina. Riportate su run mode per riprendere il funzionamento.

CONFIG ERROR  
TURN KEY TO PROGRAM

I dati di configurazione sono stati alterati.

**RIPRISTINAMENTO:** Richiedete l'assistenza di personale dirigente per riconfigurare la macchina. Riportate su run mode per riprendere il funzionamento.



name FAILED  
CHECK THIS BOARD

Una scheda del circuito è guasta o mancante.

**RIPRISTINAMENTO:** Premete **ESCAPE**. Richiedete l'assistenza di personale dirigente per verificare che i valori di configurazione si adattino all'apparecchiatura. Se il messaggio riappare, richiedete l'intervento di assistenza autorizzata.

INVALID PASSWORD

Una password non valida è stata inserita durante l'intervento manuale.

**RIPRISTINAMENTO:** Inserite una password valida.

INVALID WORK ORDER

Il numero d'ordine di lavoro non è presente nella memoria Mildata.

**RIPRISTINAMENTO:** Inserite un numero valido.

INVALID GOODS CODE

Il codice della biancheria non è presente nella memoria Mildata.

**RIPRISTINAMENTO:** Inserite un numero valido.

INVALID CUST CODE

Il codice del cliente non è presente nella memoria Mildata.

**RIPRISTINAMENTO:** Inserite un numero valido.

INVALID EMPLOYEE #

Il numero di codice dell'impiegato non è presente nella memoria Mildata.

**RIPRISTINAMENTO:** Inserite un numero valido.

INVALID FORMULA

Il numero della formula non è presente nella memoria Mildata.

**RIPRISTINAMENTO:** Inserite un numero valido.

INVALID FORM DATA

I dati relativi alla formula ricevuti da Mildata non sono validi.

**RIPRISTINAMENTO:** Richiedete l'assistenza di personale dirigente per controllare i dati relativi alla formula presenti in Mildata.

DATA UNLOCATABLE

Mildata non è riuscita a localizzare i dati relativi alla formula per la macchina richiesta.

**RIPRISTINAMENTO:** Richiedete l'assistenza di personale dirigente per verificare che la macchina sia correttamente configurata in Mildata.

## Interruzioni Richiedenti Manutenzione Autorizzata

—Questi errori richiedono generalmente l'accesso ai componenti meccanici o elettrici. Richiedete manutenzione autorizzata secondo le informazioni di sicurezza pubblicate. Consultate il manuale per la sicurezza.

\*-KEY PAD ERROR-\*  
key name

Una chiave della tastiera era bloccata o aveva subito un cortocircuito.

**RIPRISTINAMENTO:** Richiedete assistenza autorizzata.

BRAKE FAULT, MUST BE  
CLEARED TO RESTART

L'interruttore pressione freni ha rilevato nell'allentamento del freno del cilindro ad aria, pressione d'aria insufficiente a garantire che il freno si sia allentato.

**RIPRISTINAMENTO:** Richiedete assistenza autorizzata. Il messaggio scompare quando l'interruttore trova una pressione adeguata.

normal run message  
CHECK LEVEL SWITCH

L'interruttore livello non ha funzionato in modo corretto.

**RIPRISTINAMENTO:** Richiedete assistenza autorizzata.

normal run message  
CHECK type PROBE

La sonda della temperatura dell'acqua o del vapore non ha funzionato in modo corretto.

**RIPRISTINAMENTO:** Richiedete assistenza autorizzata.

SPEED SWITCH OPEN

Il circuito dell'interruttore di velocità è aperto.

**RIPRISTINAMENTO:** Se il cilindro è fisso, richiedete l'intervento di manutenzione autorizzata. Il messaggio scompare quando il circuito si chiude.

normal run message  
RECYCLE FAILURE

La macchina ha riciclato cinque volte in un'unica fase di centrifuga. La macchina tenta di bilanciare il carico ripetendo la fase precedente.

**RIPRISTINAMENTO:** Se il messaggio riappare, richiedete l'intervento di assistenza autorizzata.

normal run message  
TOO LONG TO COOL

Il tempo di raffreddamento graduale configurato è stato superato.

**RIPRISTINAMENTO:** Richiedete l'intervento di assistenza autorizzata per controllare il sistema di raffreddamento graduale. Il messaggio scompare quando il raffreddamento della temperatura è stato raggiunto.

normal run message  
TOO LONG TO FILL

Il tempo di riempimento configurato è stato superato.

**RIPRISTINAMENTO:** Richiedete l'intervento di manutenzione autorizzata per controllare il sistema di alimentazione dell'acqua. Il messaggio scompare quando la macchina si riempie.

normal run message  
TOO LONG TO STEAM

Il tempo configurato per raggiungere la temperatura di vapore desiderata è stato superato.

**RIPRISTINAMENTO:** Richiedete l'intervento di assistenza autorizzata per controllare il sistema di vapore. Il messaggio scompare quando viene raggiunta la temperatura.

## Interruzioni Che Si Riattivano Da Sè

AMPSAVER HALT

Ampsaver sta impedendo la centrifuga fin quando la corrente fornita da altre macchine nel sistema scende al di sotto di un livello specifico. Il messaggio scompare quando comincia la centrifuga. **ATTENZIONE:** Questo messaggio dovrebbe comparire solo se la macchina è on line col sistema Ampsaver.

MILTRENCH HALT

Miltrench sta impedendo che la macchina scarichi fin quando altre macchine non finiscono di scaricare. Il messaggio scompare quando comincia lo svuotamento. **ATTENZIONE:** Questo messaggio dovrebbe comparire solo se la macchina è on line con il sistema Miltrench.