

Published Manual Number/ECN: MQVSEM01U1/2016252A

- Publishing System: TPAS2
- Access date: 06/14/2016
- Document ECNs: Latest

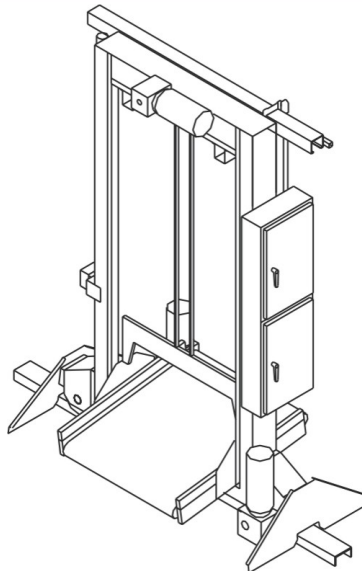

CA3605CS, CA3608PS, CA3608PSA, CK4010FS, COELF



MQVSEM01U1/16252A

1
3

1. English

Maintenance Guide—Heavy Elevator (pressed cakes or loose goods)

MQVSEM01EN/20120823

English

1



**Read the
separate
safety
manual
before
installing,
operating,
or servicing**

Published Manual Number: MQVSEM01EN

- Specified Date: 20120823
- As-of Date: 20120823
- Access Date: 20120823
- Depth: Detail
- Custom: n/a
- Applicability: VSE VGF
- Language Code: ENG01, Purpose: publication, Format: 1colA

Maintenance Guide—

Heavy Elevator (pressed cakes or loose goods)

Applicable Milnor® products by model number:

COELD111	COELF111	COELF112	COELF113	COELF121	COELF122	CA3605CS
CA3608CS	CA3608PS	CA3610CS	CA4005XS	CA4008CS	CA4008XS	CA4010CS
CA4010XS	CK4010FS					

Table of Contents

Sections	Figures, Tables, and Supplements
Chapter 1. Machine Description, Identification, and Certification	
1.1. About This Milnor® Machine—Heavy Elevator (pressed cakes or loose goods) (Document BIUUUF01)	
1.1.1. Functional Description	
1.1.2. Machine Identification	Figure 1: Machine Data Plate Supplement 1: About Machines With Multiple Data Plates
1.2. General Content of the EC-Declaration of Conformity (Document BIPCUL01)	
1.3. Machines to Move Linen—Types and Maintenance Differences (Document BIVUUF01)	Table 1: Types of Machines to Move Linen and Primary Components of Each
Chapter 2. Safety	
2.1. Safety—Shuttle (Document BIUUUS27)	
2.1.1. General Safety Requirements—Vital Information for Management Personnel (Document BIUUUS04)	
2.1.1.1. Laundry Facility	
2.1.1.2. Personnel	
2.1.1.3. Safety Devices	
2.1.1.4. Hazard Information	
2.1.1.5. Maintenance	
2.1.2. Safety Alert Messages—Internal Electrical and Mechanical Hazards (Document BIUUUS11)	
2.1.3. Safety Alert Messages—External Mechanical Hazards (Document BIUUUS12)	
2.1.4. Safety Alert Messages—Unsafe Conditions (Document BIUUUS14)	
2.1.4.1. Damage and Malfunction Hazards	
2.1.4.1.1. Hazards Resulting from Inoperative Safety Devices	
2.1.4.1.2. Hazards Resulting from Damaged Mechanical Devices	
2.1.4.2. Careless Use Hazards	
2.1.4.2.1. Careless Operation Hazards—Vital Information for Operator Personnel (see also operator hazards throughout manual)	

Sections	Figures, Tables, and Supplements
<ul style="list-style-type: none"> 2.1.4.2.2. Careless Servicing Hazards—Vital Information for Service Personnel (see also service hazards throughout manuals) 	
<p>2.2. How To Use the Safety Pins on the Shuttle / COBUC Conveyor (Document BIUUUS06)</p>	<p>Figure 2: Safety Pins for Shuttle Models</p>
<p>Chapter 3. Routine Maintenance</p>	
<p>3.1. Routine Maintenance—Heavy Elevator (pressed cakes or loose goods) (Document BIUUM09)</p>	
<ul style="list-style-type: none"> 3.1.1. How To Show the Maintenance On a Calendar 3.1.2. Maintenance Summary 3.1.3. How to Remove Contamination 3.1.4. Lubricant Identification and Procedures <ul style="list-style-type: none"> 3.1.4.1. Grease Gun Procedures 3.1.4.2. Procedures for Motors 3.1.5. Maintenance Components—Machines and Controls Group (Document BIUUM10) 	<ul style="list-style-type: none"> Table 2: Where to Put Marks On a Calendar Table 3: Guards and Related Components Table 4: Filters, Screens, and Sensitive Components Table 5: Fluid Containers Table 6: Components that Become Worn Table 7: Bearings and Bushings. See Table 8 for Motors. Table 8: Motor Grease Schedule. Use the data in Section 3.1.4.2 to complete this table. Table 9: Contamination Types, Cleaning Agents, and Procedures Table 10: Lubricant Identification Figure 3: Motor Grease Maintenance Conditions Table 11: Motor Grease Intervals and Quantities. Use grease EM (Table 10) Figure 4: Electric Box and Inverter. These are examples. Your machine can look different. Supplement 2: How to Examine Compressed Air Mechanisms Figure 5: Photoeyes. These are examples. Your machine can look different. Figure 6: Proximity Switches These are examples. Your machine can look different. Supplement 3: How to Do a Test of Emergency Stop Mechanisms Supplement 4: How to Do a Test of a Perimeter Safe-guarding System

Sections	Figures, Tables, and Supplements
3.1.6. Conveyor and Shuttle Group (Document BIVUUM03)	<p>Figure 7: Grease Ports for End Roller Bearings. These are examples. Your machine can look different. All conveyor belts have four end roller bearings with grease ports.</p> <p>Supplement 5: How to Adjust Conveyor Belt Tension and Prevent Side Movement</p> <p>Figure 8: Conveyor Belt Tension Adjustment. These are examples. Your machine can look different.</p> <p>Figure 9: Elevator Maintenance—Milnor® Hoist</p> <p>Supplement 6: Elevator Malfunctions That You Can Possibly Correct Immediately</p> <p>Figure 10: Elevator Proximity Switches and Targets</p> <p>Figure 11: Compressed Air Mechanisms on Wet Goods Shuttles and Some Loose Goods Shuttles (see).</p>

Chapter 1

Machine Description, Identification, and Certification

BIUUUF01 (Published) Book specs- Dates: 20120823 / 20120823 / 20120823 Lang: ENG01 Applic: VSE VGF

1.1. About This Milnor[®] Machine—Heavy Elevator (pressed cakes or loose goods)

This manual applies to the Milnor products whose model numbers are listed inside the front cover and which are in the families of machines defined below.

1.1.1. Functional Description

Laundering system machines perform some process within a commercial or industrial laundering system. Laundering system machines manufactured by Milnor[®] include CBW[®] tunnel washers, centrifugal extractors, press extractors, pass-through dryers, lint collectors, and various types of conveyors including stationary, shuttle, load, discharge, and storage conveyors.

Heavy Elevator (pressed cakes or loose goods) models move cakes of linen or loose goods vertically from a load station in front of a dryer to the dryer door which is at a higher level and insert the linen in the dryer. These models have a heavy frame for heavy linen weight applications.

1.1.2. Machine Identification

Find the model number and other data for your machine on the machine data plate affixed to the machine. See the figure that follows.

Figure 1: Machine Data Plate

View of Data Plate (English text shown)		Legend
		<ol style="list-style-type: none"> 1. Model number. See inside the front cover of this manual. 2. Data that uniquely identifies your machine 3. Cylinder maximum rotation speed in revolutions per minute, if applicable 4. Cylinder volume in the units of measure shown, if applicable 5. Piped utility requirements 6. Hydraulic oil pressure, if applicable 7. Electrical requirements 8. Part number for multi-unit machine, if applicable.

Supplement 1

About Machines With Multiple Data Plates

Machines shipped as multiple units for assembly on site (example: CBW tunnel washer) will have multiple data plates—one for each unit and a master plate for the complete machine, located on the primary unit. Although each unit can have a different model number, they will all share the same basic serial number. The basic serial number is usually 8 digits. Some of the units will have a two-digit suffix at the end of the serial number.

— End of BIUUUF01 —

BIPCUL01 (Published) Book specs- Dates: 20120823 / 20120823 / 20120823 Lang: ENG01 Applic: VSE VGF

1.2. General Content of the EC-Declaration of Conformity

Manufacturer: Pellerin Milnor Corporation

Hereby we declare under our sole responsibility that the machinery

- Type (see the declaration for your machine)
- Serial no (see the declaration for your machine)
- Manufacturing date (see the declaration for your machine)

is in conformity with the provisions of

- 2006/42/EC (17 May 2006) - Machinery
- 2004/108/EC (15 December 2004) - Electromechanical compatibility
- 2006/95/EC (12 December 2006) - Low voltage

Pellerin Milnor Corporation certifies that the machine(s) listed above, manufactured in Kenner, Louisiana, 70063, USA conform(s) as stipulated by schedule of verification of

- ISO 10472-1:1997 - Safety requirements for industrial laundry machinery - Part 1: Common requirements

ISO 10472-3:1997 - Safety requirements for industrial laundry machinery - Part 3: Washing tunnel lines including component machines
ISO 13857:2008 - Safety of machinery - Safety distances to prevent hazard zones being reached by upper and lower limbs
EN 61000-6-3:2007/A1:2011 - Emission standard for residential, commercial and light-industrial environments
EN 61000-6-4:2007/A1:2011 - Emission standard for industrial environments
EN 60204-1:2006/A1:2009 - Safety of machinery - Electrical equipment of machines, Part One, General requirements.

Safety compliance to the standard is described in detail in MILNOR manual (see the declaration for your machine).

This letter confirms that the machine(s) only meets the required aforementioned standards. It is the responsibility of the installer/owner of the machine(s) to ensure compliance with all requirements for on-site preparation, installation, and operation.

Our conformance to the above listed standards is certified with exceptions listed in MILNOR Conformance Report (see the declaration for your machine).

Place Kenner, Louisiana, 70063, USA
Date of first issue of above mentioned machine type
Signature Kenneth W. Gaulter Engineering Manager

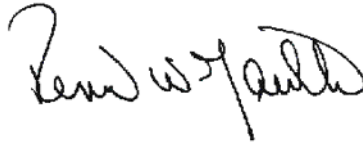

Signature Russell H. Poy Vice President, Engineering

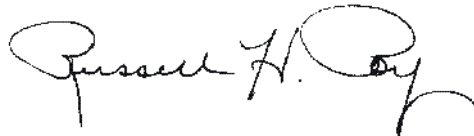

— End of BIPCUL01 —

BIVUUF01 (Published) Book specs- Dates: 20120823 / 20120823 / 20120823 Lang: ENG01 Applic: VSE VGF

1.3. Machines to Move Linen—Types and Maintenance Differences

Maintenance guides specific to each type are available. This guide is for the type: **Heavy Elevator (pressed cakes or loose goods)**. **Table 1** is a cross-reference of the machine types and the components with necessary maintenance that apply to each type.

Table 1: Types of Machines to Move Linen and Primary Components of Each

Types of Machines to Move Linen										
	Cart Drive Bucket Shuttle (wet goods) ↓									↓
	Tractor Drive Bucket Shuttle (wet goods) ↓									↓
	Travel-only Shuttle (loose goods) ↓									↓
	Light Elevator (pressed cakes) ↓									↓
	Cart Drive Shuttle (pressed cakes or loose goods) ↓									↓
	Heavy Elevator (pressed cakes or loose goods) ↓									↓
	Tractor Drive Shuttle (pressed cakes or loose goods) ↓									↓
	Press Discharge Conveyor, Pivot (pressed cakes) ↓									↓
	CBW® Load/Weigh Conveyor (loose batches) ↓									↓
	Simple Conveyor (pressed cakes or loose goods) ↓									↓
Components With Necessary Maintenance										
inverter (@ = optional)	@	@	@	X	@	X	@	X	X	X
belt-to-belt drive chain (@ = some models)	@									
weigh scale (@ = CONWA_ models)		@								
conveyor belts	X	X	X	X	X	X	X	X	X	
photoeyes	X	X	X	X	X	X	X	X	X	
proximity switches			X	X	X	X	X	X	X	X
emergency stop mechanisms	X	X	X	X	X	X	X	X	X	X
external proximity guarding			X	X	X	X	X	X	X	X
tractor with two wheels and track guides				X					X	
light cart with four wheels (one bearing each) and plastic track guides						*				
heavy cart with four wheels (two bearings each) and plastic track guides						*		X		X
Milnor hoist				X	X					
Demag DC-Pro 10 or DC-Pro 20 hoist						X	X			
Speed reducers (@ = Sealed. No oil maintenance)	@	@	@	@	@	@	@	@	@	@
bed plastic guides and guide rollers				X	X	X	X		X	X
air cylinders (@ = loose goods, extend models)				@	@	@	@	@	X	X
oil injector for air line									X	X
safety pins (and bar on wet goods shuttles)				X	X	X	X		X	X
* All cart drive shuttles have a light cart except for COSHR_ models which have a heavy cart.										

— End of BIVUUF01 —

Chapter 2

Safety

BIUUUS27 (Published) Book specs- Dates: 20120823 / 20120823 / 20120823 Lang: ENG01 Applic: VSE VGF

2.1. Safety—Shuttle

2.1.1. General Safety Requirements—Vital Information for Management Personnel [Document BIUUUS04]

Incorrect installation, neglected preventive maintenance, abuse, and/or improper repairs, or changes to the machine can cause unsafe operation and personal injuries, such as multiple fractures, amputations, or death. The owner or his selected representative (owner/user) is responsible for understanding and ensuring the proper operation and maintenance of the machine. The owner/user must familiarize himself with the contents of all machine instruction manuals. The owner/user should direct any questions about these instructions to a Milnor® dealer or the Milnor® Service department.

Most regulatory authorities (including OSHA in the USA and CE in Europe) hold the owner/user ultimately responsible for maintaining a safe working environment. Therefore, the owner/user must do or ensure the following:

- recognize all foreseeable safety hazards within his facility and take actions to protect his personnel, equipment, and facility;
- work equipment is suitable, properly adapted, can be used without risks to health or safety, and is adequately maintained;
- where specific hazards are likely to be involved, access to the equipment is restricted to those employees given the task of using it;
- only specifically designated workers carry out repairs, modifications, maintenance, or servicing;
- information, instruction, and training is provided;
- workers and/or their representatives are consulted.

Work equipment must comply with the requirements listed below. The owner/user must verify that installation and maintenance of equipment is performed in such a way as to support these requirements:

- control devices must be visible, identifiable, and marked; be located outside dangerous zones; and not give rise to a hazard due to unintentional operation;
- control systems must be safe and breakdown/damage must not result in danger;
- work equipment is to be stabilized;
- protection against rupture or disintegration of work equipment;

- guarding, to prevent access to danger zones or to stop movements of dangerous parts before the danger zones are reached. Guards to be robust; not give rise to any additional hazards; not be easily removed or rendered inoperative; situated at a sufficient distance from the danger zone; not restrict view of operating cycle; allow fitting, replacing, or maintenance by restricting access to relevant area and without removal of guard/protection device;
- suitable lighting for working and maintenance areas;
- maintenance to be possible when work equipment is shut down. If not possible, then protection measures to be carried out outside danger zones;
- work equipment must be appropriate for preventing the risk of fire or overheating; discharges of gas, dust, liquid, vapor, other substances; explosion of the equipment or substances in it.

2.1.1.1. Laundry Facility—Provide a supporting floor that is strong and rigid enough to support—with a reasonable safety factor and without undue or objectionable deflection—the weight of the fully loaded machine and the forces transmitted by it during operation. Provide sufficient clearance for machine movement. Provide any safety guards, fences, restraints, devices, and verbal and/or posted restrictions necessary to prevent personnel, machines, or other moving machinery from accessing the machine or its path. Provide adequate ventilation to carry away heat and vapors. Ensure service connections to installed machines meet local and national safety standards, especially regarding the electrical disconnect (see the National Electric Code). Prominently post safety information, including signs showing the source of electrical disconnect.



WARNING 1: Collision, Crushing and Pinch Hazards—Serious bodily injury or death can result to personnel in proximity to machinery/systems that traverse, elevate, extend, pivot, and/or tilt. The following mandatory minimum safety requirements must be installed with the machinery system: • Safety fence inclosing machine movement areas, • Lockable electrical interlocks on all gates, properly interfaced as shown on machine schematics, to disable machine movement when any gate is opened, • Signs to alert personnel to these hazards, placed prominently around the fenced area. Local codes may require additional precautions.

2.1.1.2. Personnel—Inform personnel about hazard avoidance and the importance of care and common sense. Provide personnel with the safety and operating instructions that apply to them. Verify that personnel use proper safety and operating procedures. Verify that personnel understand and abide by the warnings on the machine and precautions in the instruction manuals.

2.1.1.3. Safety Devices—Ensure that no one eliminates or disables any safety device on the machine or in the facility. Do not allow machine to be used with any missing guard, cover, panel or door. Service any failing or malfunctioning device before operating the machine.

2.1.1.4. Hazard Information—Important information on hazards is provided on the machine safety placards, in the Safety Guide, and throughout the other machine manuals. **Placards must be kept clean so that the information is not obscured. They must be replaced immediately if lost or damaged. The Safety Guide and other machine manuals must be available at all times to the appropriate personnel.** See the machine service manual for safety placard part numbers. Contact the Milnor Parts department for replacement placards or manuals.

2.1.1.5. Maintenance—Ensure the machine is inspected and serviced in accordance with the norms of good practice and with the preventive maintenance schedule. Replace belts, pulleys, brake shoes/disks, clutch plates/tires, rollers, seals, alignment guides, etc. before they are severely worn. Immediately investigate any evidence of impending failure and make needed repairs (e.g., cylinder, shell, or frame cracks; drive components such as motors, gear boxes, bearings, etc., whining, grinding, smoking, or becoming abnormally hot; bending or cracking of cylinder, shell, frame, etc.; leaking seals, hoses, valves, etc.) Do not permit service or maintenance by unqualified personnel.

2.1.2. Safety Alert Messages—Internal Electrical and Mechanical Hazards [Document BIUUUS11]

The following are instructions about hazards inside the machine and in electrical enclosures.



WARNING 2: Electrocutation and Electrical Burn Hazards—Contact with electric power can kill or seriously injure you. Electric power is present inside the cabinetry unless the main machine power disconnect is off.

- Do not unlock or open electric box doors.
- Do not remove guards, covers, or panels.
- Do not reach into the machine housing or frame.
- Keep yourself and others off of machine.
- Know the location of the main machine disconnect and use it in an emergency to remove all electric power from the machine.



WARNING 3: Entangle and Crush Hazards—Contact with moving components normally isolated by guards, covers, and panels, can entangle and crush your limbs. These components move automatically.

- Do not remove guards, covers, or panels.
- Do not reach into the machine housing or frame.
- Keep yourself and others off of machine.
- Know the location of all emergency stop switches, pull cords, and/or kick plates and use them in an emergency to stop machine motion.

2.1.3. Safety Alert Messages—External Mechanical Hazards [Document BIUUUS12]

The following are instructions about hazards around the front, sides, rear or top of the machine.



CAUTION 4: Strike and Crush Hazards—A traveling machine such as a shuttle can strike, crush, or entrap you if you ride on it or enter its path. Traveling machines or their components can move automatically in any direction. Placing a system machine on line by energizing the machine control may immediately summon a shuttle or other traveling machine.

- Keep yourself and others off of machine.
- Keep yourself and others clear of movement areas and paths.
- Understand the consequences of placing a system machine on line.
- Know the location of all emergency stop switches, pull cords, and/or kick plates and use them in an emergency to stop machine motion.
- Know the location of the main machine disconnect and use it in an emergency to remove all electric power from the machine.



CAUTION 5: Crush and Entrap Hazards—A traveling machine such as a shuttle can crush or entrap you if the bed or bucket descends while you are under it. The bed or bucket can descend with power off or on.

- Keep yourself and others clear of movement areas and paths.



WARNING 6: Fall, Entangle, and Strike Hazards—Machine motion can cause you to fall or become entangled in or struck by nearby objects if you stand, walk, or ride on the machine. Shuttles and conveyor belts move automatically.

- Keep yourself and others off of machine.

2.1.4. Safety Alert Messages—Unsafe Conditions [Document BIUUUS14]

2.1.4.1. Damage and Malfunction Hazards

2.1.4.1.1. Hazards Resulting from Inoperative Safety Devices



WARNING 7: Multiple Hazards—Operating the machine with an inoperative safety device can kill or injure personnel, damage or destroy the machine, damage property, and/or void the warranty.

- Do not tamper with or disable any safety device or operate the machine with a malfunctioning safety device. Request authorized service.



WARNING 8: Electrocutation and Electrical Burn Hazards—Electric box doors—Operating the machine with any electric box door unlocked can expose high voltage conductors inside the box.

- Do not unlock or open electric box doors.



WARNING 9: Entangle and Crush Hazards—Guards, covers, and panels—Operating the machine with any guard, cover, or panel removed exposes moving components.

- Do not remove guards, covers, or panels.

2.1.4.1.2. Hazards Resulting from Damaged Mechanical Devices



WARNING 10: Multiple Hazards—Operating a damaged machine can kill or injure personnel, further damage or destroy the machine, damage property, and/or void the warranty.

- Do not operate a damaged or malfunctioning machine. Request authorized service.

2.1.4.2. Careless Use Hazards

2.1.4.2.1. Careless Operation Hazards—Vital Information for Operator Personnel (see also operator hazards throughout manual)



WARNING 11: Multiple Hazards—Careless operator actions can kill or injure personnel, damage or destroy the machine, damage property, and/or void the warranty.

- Do not tamper with or disable any safety device or operate the machine with a malfunctioning safety device. Request authorized service.
- Do not operate a damaged or malfunctioning machine. Request authorized service.
- Do not attempt unauthorized servicing, repairs, or modification.

- Do not use the machine in any manner contrary to the factory instructions.
- Use the machine only for its customary and intended purpose.
- Understand the consequences of operating manually.



CAUTION 12: Goods Damage and Wasted Resources—Entering incorrect cake data causes improper processing, routing, and accounting of batches.

- Understand the consequences of entering cake data.



WARNING 13: Strike and Crush Hazards—Carelessly moving the machine with manual controls can cause it to strike, crush, entrap, or entangle personnel. You have total control of machine movement immediately after setting the Manual/Automatic switch to manual.

- Keep yourself and others clear of movement areas and paths.
- Understand the consequences of operating manually.

2.1.4.2.2. Careless Servicing Hazards—Vital Information for Service Personnel (see also service hazards throughout manuals)



WARNING 14: Electrocutation and Electrical Burn Hazards—Contact with electric power can kill or seriously injure you. Electric power is present inside the cabinetry unless the main machine power disconnect is off.

- Do not service the machine unless qualified and authorized. You must clearly understand the hazards and how to avoid them.
- Abide by the current OSHA lockout/tagout standard when lockout/tagout is called for in the service instructions. Outside the USA, abide by the OSHA standard in the absence of any other overriding standard.



WARNING 15: Entangle and Crush Hazards—Contact with moving components normally isolated by guards, covers, and panels, can entangle and crush your limbs. These components move automatically.

- Do not service the machine unless qualified and authorized. You must clearly understand the hazards and how to avoid them.
- Abide by the current OSHA lockout/tagout standard when lockout/tagout is called for in the service instructions. Outside the USA, abide by the OSHA standard in the absence of any other overriding standard.



WARNING 16: Crush and Entrap Hazards—A traveling machine such as a shuttle can crush or entrap you if the bed or bucket descends while you are under it. The bed or bucket can descend with power off or on.

- Secure both red safety pins in accordance with the instructions furnished, then lock out and tag out power at the main machine disconnect before working under bed or bucket.



WARNING 17: Strike and Crush Hazards—A traveling machine such as a shuttle can strike, crush, or entrap you if you ride on it or enter its path. Traveling machines or their components can move automatically in any direction. Placing a system machine on line by energizing the machine control may immediately summon a shuttle or other traveling machine.

- Lock out and tag out power to the traveling machine at the main machine disconnect if you must work in the path of the traveling machine.

— End of BIUUUS27 —

2.2. How To Use the Safety Pins on the Shuttle / COBUC Conveyor

These machines are provided with two safety pins (painted red) for maintenance. After the bed is raised, the pins are inserted into holes in both sides of the frame. Use the safety pins to perform maintenance on the machine when the bed is raised. A location is provided on the machine for stowing the safety pins when not in use.



WARNING 18: **Crush Hazard**—The safety pins provide protection against the un-powered descent of the bed during maintenance in the event of a mechanical problem. **Such a condition can cause the bed to fall quickly.**

- Never work **under** the raised bed unless both safety pins are installed and power is locked out/tagged out. Do not work **near** the raised bed with power on unless both safety pins are installed.
- Install these safety components using the procedure prescribed in this document.
- Maintain these safety components in good condition.
- When not in use, stow these safety components in the location provided on the machine.

Figure 2: Safety Pins for Shuttle Models

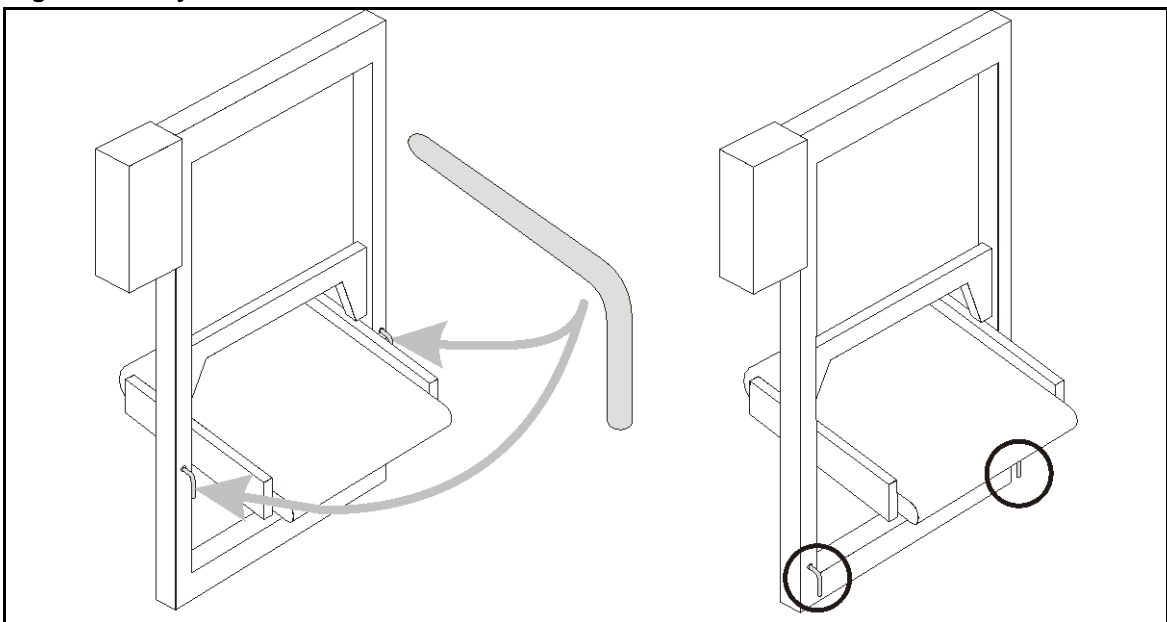

Install the safety pins as follows:

1. At the controls, use the *Manual* mode to raise the bed. Raise the bed only as far as needed to insert the pins at one of the receptacle holes.
2. Referring to the figure, place the safety pins into the receptacle holes in the frame. Always use both pins.
3. At the controls, carefully lower the bed just until it is resting on the pins.
4. Lock out/tag out power to the machine.

— End of BIUUUS06 —

Chapter 3

Routine Maintenance

BIUUUM09 (Published) Book specs- Dates: 20120823 / 20120823 / 20120823 Lang: ENG01 Applic: VSE VGF

3.1. Routine Maintenance—Heavy Elevator (pressed cakes or loose goods)



This document uses Simplified Technical English.
Learn more at <http://www.asd-ste100.org>.

Do the maintenance in [Section 3.1.2 “Maintenance Summary”](#) to make sure that the machine is safe, keeps the warranty, and operates correctly. This will also decrease repair work and unwanted shutdowns. Speak to your dealer or Milnor if repairs are necessary.



WARNING **20**: Risk of severe injury—Mechanisms can pull in and mutilate your body.

- You must be approved by your employer for this work.
- Use extreme care when you must examine components in operation. Remove power from the machine for all other work. Obey safety codes. In the USA, this is the OSHA lockout/tagout (LOTO) procedure. More local requirements can also apply.
- Replace guards and covers that you remove for maintenance.

3.1.1. How To Show the Maintenance On a Calendar

If you use software to keep the maintenance schedule for your plant, add the items in [Section 3.1.2](#) to that schedule. If not, you can put marks on a calendar that work with the tables in [Section 3.1.2](#). The marks are the numbers 2, 3, 4, 5, and 6. It is not necessary to show the number 1 (items you do each day) on the calendar. The number 2 = items you do each 40 to 60 hours, 3 = each 200 hours, 4 = each 600 hours, 5 = each 1200 hours, and 6 = each 2400 hours. These are the "Mark" numbers at the top of the narrow columns on the left of each table in [Section 3.1.2](#).

[Table 2](#) shows where to put the marks on a calendar. For example, if your machine operates between 41 and 60 hours each week, the first three marks are 2, 2, and 3. Put these marks on the first, second, and third weeks after the machine starts operation. If you do routine maintenance on a given day of the week, put the mark on that day of each week. Continue to put marks on the subsequent weeks. **It can be necessary to do the 40 to 60 hour (2) maintenance more than one time each week.** If the machine operates between 61 and 100 hours, put a 2 on two days of the week. If the machine operates 101 or more hours, put a 2 on three days of the week.

On each date with a 3, do the items with an x in the 3 or the 2 column of each table in [Section 3.1.2](#). On each date with a 4, do the items with an x in the 4, 3, or 2 column. Continue this pattern.

Table 2: Where to Put Marks On a Calendar

Hours / Week	Week Number																													
	1	2	3	4	5	6	7	8	9	10	11	12	13	14	15	16	17	18	19	20	21	22	23	24	25	26	27	28	29	30
Up to 40	2	2	2	2	3	2	2	2	2	3	2	2	2	2	4	2	2	2	2	3	2	2	2	2	3	2	2	2	2	5
41 - 60	2	2	3	2	2	2	3	2	2	4	2	2	3	2	2	2	3	2	2	5	2	2	3	2	2	2	3	2	2	4
61 - 80	2	2	3	2	3	2	4	2	2	3	2	2	3	2	5	2	3	2	2	3	2	4	2	2	3	2	2	3	2	6
81 - 100	2	3	2	3	2	4	2	3	2	3	2	5	2	3	2	3	2	4	2	3	2	3	2	6	repeat					
101 - 120	2	3	2	3	4	2	3	2	3	5	2	3	2	3	4	2	3	2	3	6	repeat									
121 - 140	2	3	2	3	4	3	2	3	5	2	3	2	3	4	3	2	3	6	repeat											
Hours / Week	Week Number, continued																													
	31	32	33	34	35	36	37	38	39	40	41	42	43	44	45	46	47	48	49	50	51	52	53	54	55	56	57	58	59	60
Up to 40	2	2	2	2	3	2	2	2	2	3	2	2	2	2	4	2	2	2	2	3	2	2	2	2	3	2	2	2	6	
41 - 60	2	2	3	2	2	2	3	2	2	6	repeat																			

3.1.2. Maintenance Summary

The tables in this section give the routine maintenance items for your machine. Each table is for one type of procedure (example: apply grease to bearings and bushings). The top of the table gives the general procedure. The "More Data" column gives special instructions if necessary.

* If the machine operates more than 12 hours each day, do the "day" items two times each day. Do the other items at the given hours or on the days that you show on a calendar (see Section 1). **Do all items in all tables for the maintenance intervals that apply (for example, day, 40 to 60 hours, and 200 hours).**

Tip: The sections that follow the maintenance summary give more data about the maintenance items. After you know this data, it is only necessary to look at the summary to do the maintenance.

Table 3: Guards and Related Components

Examine. If a component is damaged, missing, or not set, correct this immediately to prevent injury.								
Mark						Do this each	Component	More Data
1	2	3	4	5	6			
x						day*	guards, covers	Speak to your dealer or Milnor for replacement components.
x						day*	safety placards	
		x				200 hours	fasteners	Fasteners must be tight.
x						day*	safety stands, bars or pins (painted red)	Speak to your dealer or Milnor for replacement components.
		x				200 hours	anchor bolts and grout	Grout must be good. Bolts must be tight.
x						day*	emergency stop mechanism	See Supplement 3 . Do a test of the control.
	x					40 to 60 hours	safety circuit for the gates in the fence that goes around the path of the shuttle conveyor	See Supplement 4 . Do a test of the circuit. If it does not operate correctly, repairs are necessary. This circuit is provided by others.

Table 4: Filters, Screens, and Sensitive Components

Remove contamination from these components to prevent damage and unsatisfactory performance.								
Mark						Do this each	Component	More Data. See also Section 3.1.3 “How to Remove Contamination”
1	2	3	4	5	6			
The next item only applies if the conveyor has an optional inverter.								
	x					40 to 60 hours	inverter fans, vents, filters	See Figure 4. Keep good air flow.
			x			600 hours	motors	Keep good air flow.
					x	2400 hours	entire machine	Remove excessive dust and dirt.
				x		1200 hours	mufflers, quick exhaust valves for air cylinders, if supplied	See Figure 11
x						day*	photoeyes	See Figure 5
					x	2400 hours	proximity switches	See Figure 6

Table 5: Fluid Containers

Examine. Add fluid if necessary and keep components clean to prevent damage.								
Mark						Do this each	Component	More Data. See also Section 3.1.4 “Lubricant Identification and Procedures”
1	2	3	4	5	6			
						none	speed reducer (gear reducer)	Sealed. No oil maintenance necessary.
			x			600 hours	air line lubricator for air cylinders, if supplied.	See Figure 11. Add oil 23 (Table 10) if necessary.

Table 6: Components that Become Worn

Examine. Tighten or replace if necessary, to prevent shutdowns and unsatisfactory performance. Speak to your dealer for replacement parts								
Mark						Do this each	Component	More Data
1	2	3	4	5	6			
x						day*	conveyor belts	See Supplement 5.
			x			600 hours	guide rollers and slides	See Figure 9.
					x	2400 hours	hoist chain	See Figure 9. If links are deformed or worn, replacement can be necessary. Speak to your dealer or Milnor. This is not routine maintenance.

Table 7: Bearings and Bushings. See Table 8 for Motors.

Apply grease to these components to prevent damage.								
Mark						Do this each	Component	More Data. See also Section 3.1.4 “Lubricant Identification and Procedures”
1	2	3	4	5	6			
		x				200 hours	conveyor roller bearings	See Figure 7. Add 0.12 oz. (3.54 mL) of grease EPLF2 (Table 10) at four places for each conveyor belt.
			x			600 hours	chain	See Figure 9. Apply spray lubricant FGL (Table 10).
			x			600 hours	sprocket shaft bearings	See Figure 9. Add 0.12 oz. (3.54 mL) of grease EPLF2 (Table 10) at two places
			x			600 hours	idler pulley	See Figure 9. Add 0.12 oz. (3.54 mL) of grease EPLF2 (Table 10) at one place.

Table 8: Motor Grease Schedule. Use the data in Section 3.1.4.2 to complete this table.

Motor Identification (example: main drive)	Interval		Quantity		Dates When Grease is Added							
	Years	Hours	fl oz	mL								

3.1.3. How to Remove Contamination

Table 9: Contamination Types, Cleaning Agents, and Procedures

Material or Component	Usual Contamination	Example	Cleaning Agent	More Data
machine housing	dust, dirt	—	compressed air or shop vacuum	Air—no more than 30 psi (207 kpa). Do not push dust in mechanisms.
fins and vents on electrical components	dust	motors, inverters, braking resistors	shop vacuum, soft bristle brush, canned air for electrical components	Do not push dust in mechanisms.
electric box interior	dust	all electric boxes		
electrical connections	corrosion, varnish	spade connector, molex connector, plug-in relay	spray solvent for electrical components	Disconnect then connect it again. Use solvent if the bad connection continues.
electronic sensors	dust	photoeye lens, reflector, laser, proximity switch, temperature probe	none	Use a clean, soft, dry cloth.
	dirt		warm water with soap, then water flush	Use clean, soft cloths.
stainless steel	chemical spill	shell, supply injector	water	Use a hose to flush the chemical supply from the surface fully. Do not get water on electrical components or mechanisms.
300 series stainless steel	chemical corrosive attack	shell interior, cylinder	pickling and passivation	Speak to your dealer or Milnor. This is not routine maintenance.
painted metal, unpainted aluminum	dust, dirt, grease	frame members	warm water with soap, then water to flush	Use clean cloths. Do not get water in electrical components.
rubber	dirt, oil, grease	drive belts, hoses	warm water with soap, then water to flush	Use clean cloths. Flush fully. Oil or soap must not stay on drive belts. Make sure that drive belts are serviceable.
clear plastic, acrylic	discoloration (yellowing)	compressed air filter bowl, visual flow meter	warm water with soap, then water to flush, then acrylic cleaner. Do not use ammonia.	Use only the necessary cleaning agents. Wash and rinse with clean, soft cloths. Follow instructions on acrylic cleaner.
glass	discoloration (yellowing)	door glass, site glass	ammonia and water solution and water rinse then acetone	Use clean, soft cloths. Use only the necessary cleaning agents. If necessary, soak in cleaner.
soft air filter, lint filter,	dust, lint	on inverter electric box door, in air line filter bowl, in dryers	shop vacuum	Replace the used with a new filter when the vacuum cannot remove contamination.
rigid strainers, screens for water, steam	mineral particles	in water line, y-strainer	water	Use a rigid bristle brush. Flush with a flow of water.
rigid strainers, screens for oil	metal shavings	in hydraulic line	carburetor cleaner or equivalent solvent	Soak. Use a rigid bristle brush.
steel drive components	dirt, hardened lubricant	bearings, roller chains, sprockets, gears	carburetor cleaner or equivalent solvent	Soak. Use a cloth or soft bristle brush.

3.1.4. Lubricant Identification and Procedures

Table 10 identifies the lubricant for each lubricant code given in the maintenance summary. Get these or equivalent lubricants from your local lubricant supplier.

When you add grease, always use the procedures given in Section 3.1.4.1. When you add grease to motors, also use the procedures given in Section 3.1.4.2.



CAUTION 21: Risk of damage—Bad lubricant will decrease the life of components.

- Make sure that all equipment and fittings used to apply lubricants are clean.
- Use only the given lubricants or equivalent lubricants that have the same specifications.

Table 10: Lubricant Identification

Code	Type	Trademark Name	Application Example
EM	grease	Mobil Polyrex EM or as given on the motor nameplate	motor bearings
EPLF2	grease	Shell Alvania EP (LF) Type 2	drive shaft bearings and bushings, ball joints, chain drives
FGL	spray	Lubriplate Super FGL-1. One can provided with machine.	Milnor hoist chain
23	oil	Shell Tellus 23	air line lubricator

3.1.4.1. Grease Gun Procedures



CAUTION 22: Risk of damage—Hydraulic pressure can push out seals and push grease into unwanted areas (example: motor windings).

- Use a hand grease gun. A power grease gun gives too much pressure.
- Know the quantity of grease your grease gun gives each cycle (each stroke).
- Operate the grease gun slowly (10 to 12 seconds for one cycle).
- Add only the specified quantity. Stop if new grease come out of a drain port or other opening.
- Remove spilled grease from belts and pulleys.

The tables give grease quantities in fluid ounces (fl oz) and milliliters (mL). You can also use grease gun cycles (strokes). A cycle is each time that you pull the trigger. One cycle is usually approximately 0.06 fl oz (1.8 mL). Your grease gun can give more or less than this. Measure the output of your grease gun as follows:

1. Make sure that the grease gun operates correctly.
2. Operate the grease gun to put grease into a small container with fluid ounce or milliliter increments. Pull the trigger fully and slowly.
3. Add a sufficient quantity of grease to measure accurately. Count the number of cycles of the grease gun (the number of times that you pull the trigger).
4. Calculate the quantity for each cycle of the grease gun.

Example: 2 fl oz / 64 cycles = 0.031 fl oz for each cycle

Example: 59 mL / 64 cycles = 0.92 mL for each cycle

3.1.4.2. Procedures for Motors—If a motor on your machine does not have grease fittings, no grease maintenance is necessary. If a motor on your machine has grease fittings, it is necessary to add grease. But the interval is usually longer than for other maintenance. [Table 11](#) gives motor grease intervals and quantities for motors with specified frame sizes and speeds. You get this data from the motor nameplate. Use [Table 8 in Section 3.1.2](#) to record the data for the motors on your machine.

Figure 3: Motor Grease Maintenance Conditions

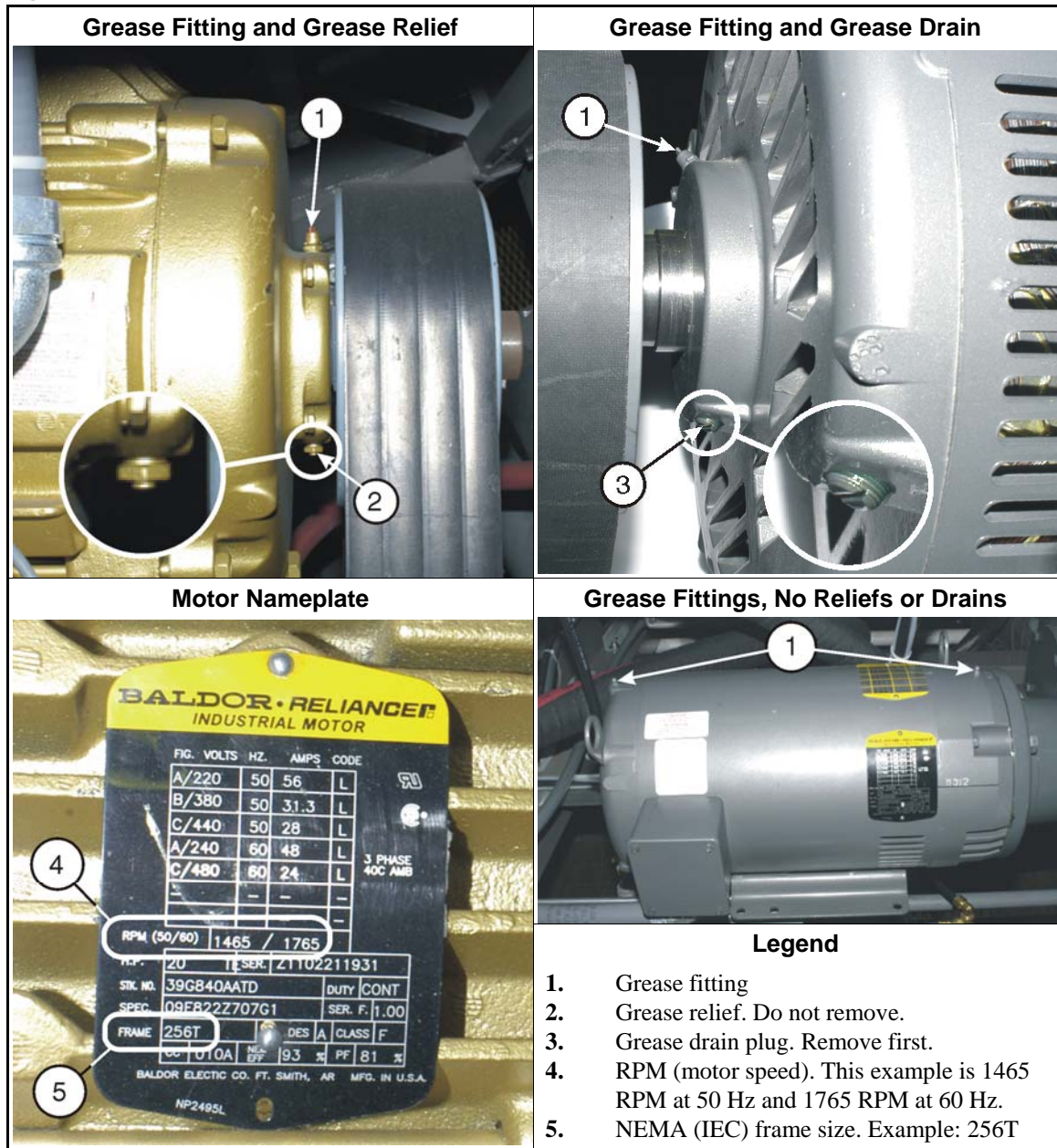

CAUTION 23: Risk of damage—You can push grease into the windings and burn out the motor if you fail to remove the grease drain plugs.

- If the motor has grease drain plugs, remove them before you add grease. If the motor has grease relief fittings, it is not necessary to remove them.

Apply grease as follows:

1. Operate the machine or use manual functions to operate the motor until it is warm.
2. Remove power from the machine.
3. If the motor has grease drain plugs, remove them. See [caution statement 23](#) .
4. Add grease EM ([Table 10](#)) with the motor stopped. If the motor with the nameplate in [Figure 3](#) operates at 60 Hz, the specified grease quantity for each grease fitting is 0.65 fl oz (18.4 mL).
5. If the motor has a grease drain plugs, operate the machine or use manual functions to operate the motor for two hours. Replace the drain plug.

Table 11: Motor Grease Intervals and Quantities. Use grease EM ([Table 10](#))

On Motor Nameplate (see Figure 3)		Interval		Quantity	
NEMA (IEC) Frame Size	RPM Less Than or Equal To	Years	Hours	Fluid Ounces	mL
Up to 210 (132)	900	5.5	11000	0.34	9.5
	1200	4.5	9000		
	1800	3	6000		
	3600	1.5	3000		
>210 to 280 (132 to 180)	900	4.5	9000	0.65	18.4
	1200	3.5	7000		
	1800	2.5	5000		
	3600	1	2000		
>280 to 360 (180 to 200)	900	3.5	7000	0.87	24.6
	1200	3	6000		
	1800	2	4000		
	3600	0.5	1000		
>360 to 5000 (200 to 300)	900	2.5	5000	2.23	63.2
	1200	2	4000		
	1800	1	2000		
	3600	0.5	1000		

3.1.5. Maintenance Components—Machines and Controls Group

[Document BIUUUM10]

Figure 4: Electric Box and Inverter. These are examples. Your machine can look different.

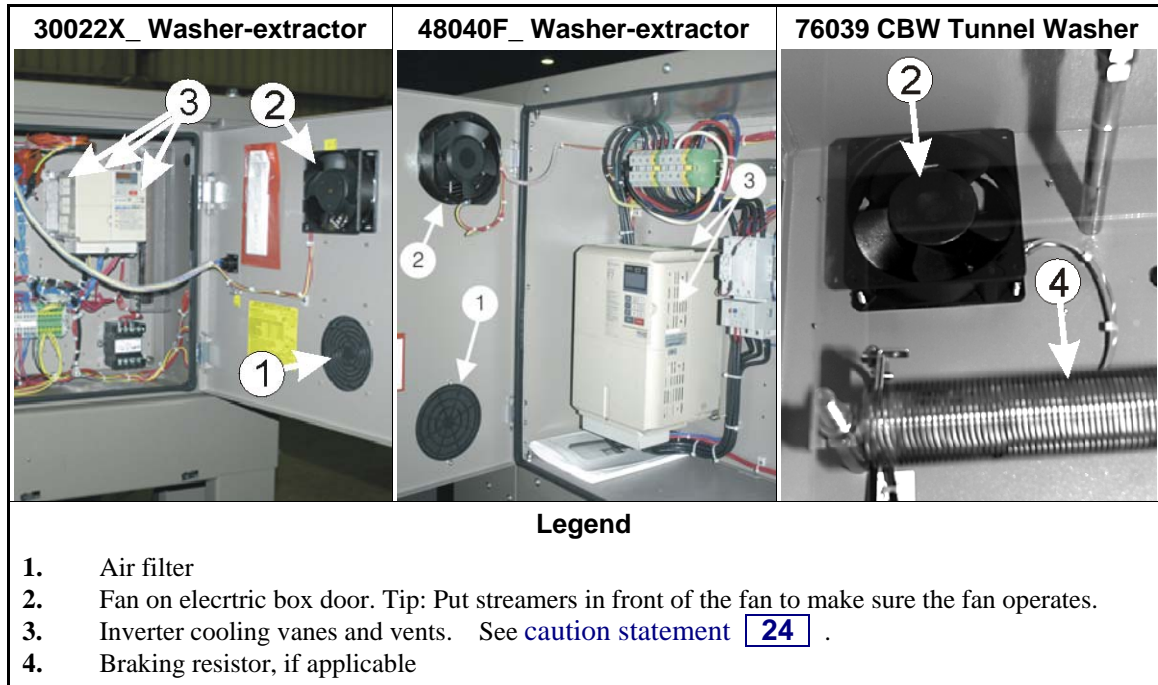

CAUTION 24: Risk of damage—The inverter will burn out without sufficient airflow.

- Keep fans, filter, vents, and braking resistors clean.

Supplement 2

How to Examine Compressed Air Mechanisms

Your machine has one or more mechanisms that use compressed air for movement. See [Figure 11](#). To examine a compressed air mechanism, look at the mechanism and listen to it in operation. **Do not touch the mechanism or put your hand in the machine.** Usually you can see movement directly or on a position indicator. Frequently, you can hear a valve open and close. When a signal from the controller to operate the mechanism occurs, the air pressure must increase sufficiently before movement occurs. When the signal stops, the system must release the compressed air. You can usually hear the sound of the exhaust air for a short time.

When a compressed air mechanism operates correctly, its time of movement is usually less than two seconds. The movement is smooth. It does not shake, change speed, or stop in the middle of travel. A mechanism that does not operate correctly will cause unsatisfactory performance. If the mechanism does not operate correctly and you cannot repair the problem, speak to your dealer or Milnor. Possible causes are as follows:

- a blockage or a leak in the air tube,
- a worn pilot air valve,
- worn components in the mechanism,
- air pressure supplied to the machine is not sufficient,
- a component used to remove contamination from the air line is clogged,
- a quick exhaust valve or muffler is clogged,

- on machines with an air line lubricator, a malfunction or incorrect adjustment prevents sufficient lubrication.

Figure 5: Photoeyes. These are examples. Your machine can look different.







<p>Photoeye protected by a site glass, each side of the CBW load chute</p>	<p>Photoeye and reflector on extractor discharge conveyor</p>
	
<p style="text-align: center;">Legend</p> <p>→. Exposed surfaces that must be clean. Remove contamination with a soft cloth. If the surface is hard to touch, use a cloth on the end of a wood dowel or metal rod. If necessary, use a safe cleaning agent.</p>	

Figure 6: Proximity Switches These are examples. Your machine can look different.

<p>1 Station Press</p> 	<p>Centrifugal Extractor</p> 	<p>Shuttle Conveyor</p> 
<p>Typical Proximity Switch</p> 	<p style="text-align: center;">Legend</p> <p>→. Area that must be clean. Remove contamination with a soft cloth. If the area is hard to touch, use a cloth on the end of a wood dowel or metal rod. If necessary, use a safe cleaning agent.</p>	

Supplement 3

How to Do a Test of Emergency Stop Mechanisms

This test applies to machines that have one or more stop mechanisms in addition to the Stop button (⓪). Do this test at the intervals given in the maintenance summary.

Definitions:

3-wire circuit—a series electrical circuit on a Milnor machine that must close before the machine can operate. If a switch in the circuit opens, machine movement stops and the operator alarm (a buzzer and a display message) comes on. When you push the start button (Ⓜ), this closes the 3-wire circuit, which stops the operator alarm and lets the machine operate.

emergency stop mechanism—a manual control that opens the 3-wire circuit when a person or object operates the control. Examples - emergency stop button, kick plate, pull cord.

emergency stop button—a red push button on a yellow field that locks when a person pushes it (the electrical contacts stay open). It is necessary to turn the button clockwise to unlock it. A machine can have zero or more emergency stop buttons.

kick plate—a metal plate on a shuttle conveyor that operates a switch when an object applies sufficient force to the plate. The kick plate is usually the first component of the shuttle to hit an object in the shuttle path. All Milnor shuttles that go left/right on a path have kick plates on the two sides of the machine.



WARNING **25**: You can be killed or severely injured if a shuttle strikes you even if you come in contact with the kick plate first.

- Never do a test of the kick plate when the shuttle operates.

pull cord—a wire on a conveyor that operates a switch when a person pulls the wire. All Milnor free-stand conveyors (a conveyor that is not a component of a larger machine) have pull cords on the two sides of the conveyor.

Do a test of all emergency stop mechanisms on the machine as follows:

1. Apply power to the machine (⊖).
2. Push the start button (Ⓜ). **Do not cause the machine to operate.** For example, do not start a formula or operate the machine manually. It is not necessary to do the test when the machine operates.
3. Operate an emergency stop mechanism (examples - button, kick plate, pull cord). If the mechanism operates correctly, the operator alarm comes on. Did this occur?

Yes—Release the emergency stop mechanism if necessary. For example, if this is an emergency stop button, turn the button clockwise to unlock it. Push the start button (Ⓜ). Do the test on a different emergency stop mechanism. Continue until you do the test on all emergency stop mechanisms on the machine.

No—An electrical component is defective. Shut down the machine. Do not let the machine operate until you correct the problem.

Supplement 4

How to Do a Test of a Perimeter Safe-guarding System

This test applies to machines that must have perimeter safe-guarding. Do this test at the intervals given in the maintenance summary.

Definitions:

perimeter safe-guarding system—a system that causes the movement of machines to stop if a person goes in the perimeter. This area includes the full shuttle path. A typical system is a fence with gates that have gate interlock switches. If a gate opens, the 3-wire circuits on the machines open.

machines that must have perimeter safe-guarding—Milnor 1- and 2-station presses, centrifugal extractors, elevators, and shuttles. These types of machines have an electrical connection point to add external switches (example - gate interlock switches) to the machine's 3-wire circuit.

other machines that can be in the perimeter—tunnel washers, dryers, and conveyors. Often, these types of machines are also enclosed because of the laundering system layout.

General rules:

- Know which machines to include in the test (machines that must have perimeter safe-guarding) and which machines to not include (other machines that can be in the perimeter).
- Do the test when the laundering system is not in operation.

Do a test of all gates as follows:

1. Make sure that all gates are closed.
2. On all machines that are in the test, apply power (⊕) and push the start button (Ⓜ).
3. Open a gate. If the circuit operates correctly, the operator alarms on all machines come on. Did this occur?

Yes—Close this gate. On all machines, push the start button (Ⓜ). Open a different gate. Continue until you do the test on all gates.

No—An electrical component is defective. Shut down the laundering system. Do not let the system operate until you correct the problem.

3.1.6. Conveyor and Shuttle Group [Document BIVUUM03]

Figure 7: Grease Ports for End Roller Bearings. These are examples. Your machine can look different. All conveyor belts have four end roller bearings with grease ports.

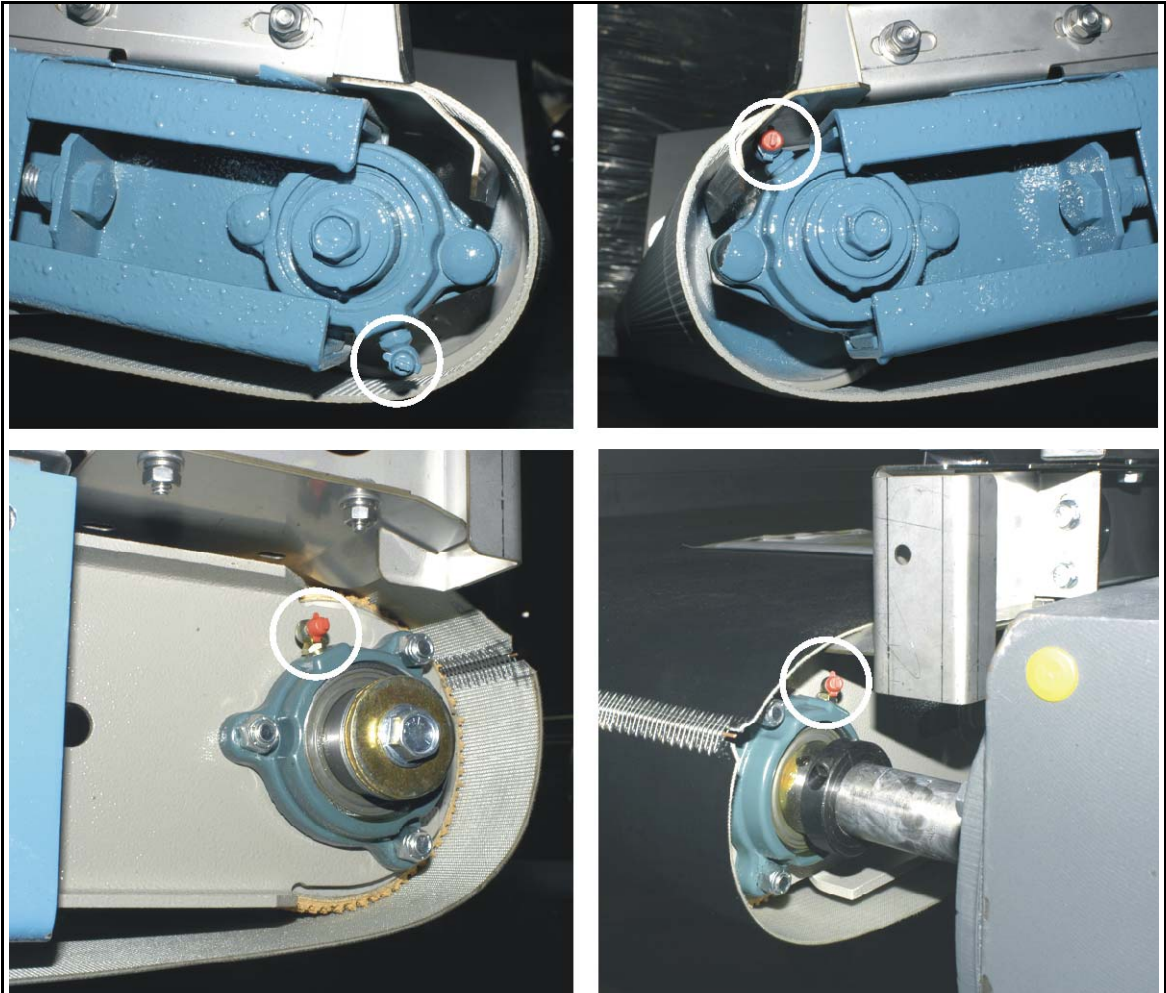

Supplement 5

How to Adjust Conveyor Belt Tension and Prevent Side Movement

This instruction is for conveyor belts in flat bed conveyors, CBW[®] load conveyors, extractor conveyors, and pivot conveyors. It is also for belts in shuttles and elevators. But shuttle and elevator belts have a bead in the center of the belt that goes in a groove in the end rollers. This causes the belt to stay in the center of the bed unless an incorrect condition is very bad.

A conveyor belt refers to one belt loop and two end rollers. Many machines have more than one conveyor belt. The conveyor belts can be one above the other or in a line.

A belt must have sufficient tension that there is no slippage on the rollers when it has a full load. In time the belt length will increase because of operation. It can become necessary to adjust the position of the rollers to put more tension on the belt. When this occurs, it is also necessary to adjust the rollers to keep the belt at the center of the bed.

If a conveyor belt starts to move away from the center of the bed, do not adjust the rollers first. This can make the condition worse. Look for the cause of the incorrect condition. Some possible causes are:

- a piece of goods wound around a roller
- a damaged belt
- a twisted conveyor bed (for example, the conveyor legs do not give equal support)

If you replaced conveyor belt components, some other possible causes are:

- The ends of the belt that attach together are not cut straight or they are not perpendicular to the belt centerline.
- Brackets that were removed (example: idler roller brackets) were not attached at the same position on each side of the bed.

If there are no other causes and the belt continues to move away from the center of the bed, adjust the rollers. The rules of belt adjustment to prevent side movement are:

- The belt will move to the loose side (the side with less belt tension).
- The best condition is when the two end rollers are perpendicular to the bed centerline.
- Make small adjustments. Adjust the two sides of the roller to keep the tension at the center of the belt the same. (Increase tension on one side and decrease tension on the other side.)
- Some belts go in the two directions at different times when the machine operates automatically. It is not necessary to get the belt to stay in the center of the bed in the two directions, only in the primary direction.

Before you adjust belt tension, examine the tension mechanisms on your machine and know how they operate. [Figure 8](#) shows some typical mechanisms, but these are not the only ones that you will find on Milnor conveyor belts.

Figure 8: Conveyor Belt Tension Adjustment. These are examples. Your machine can look different.

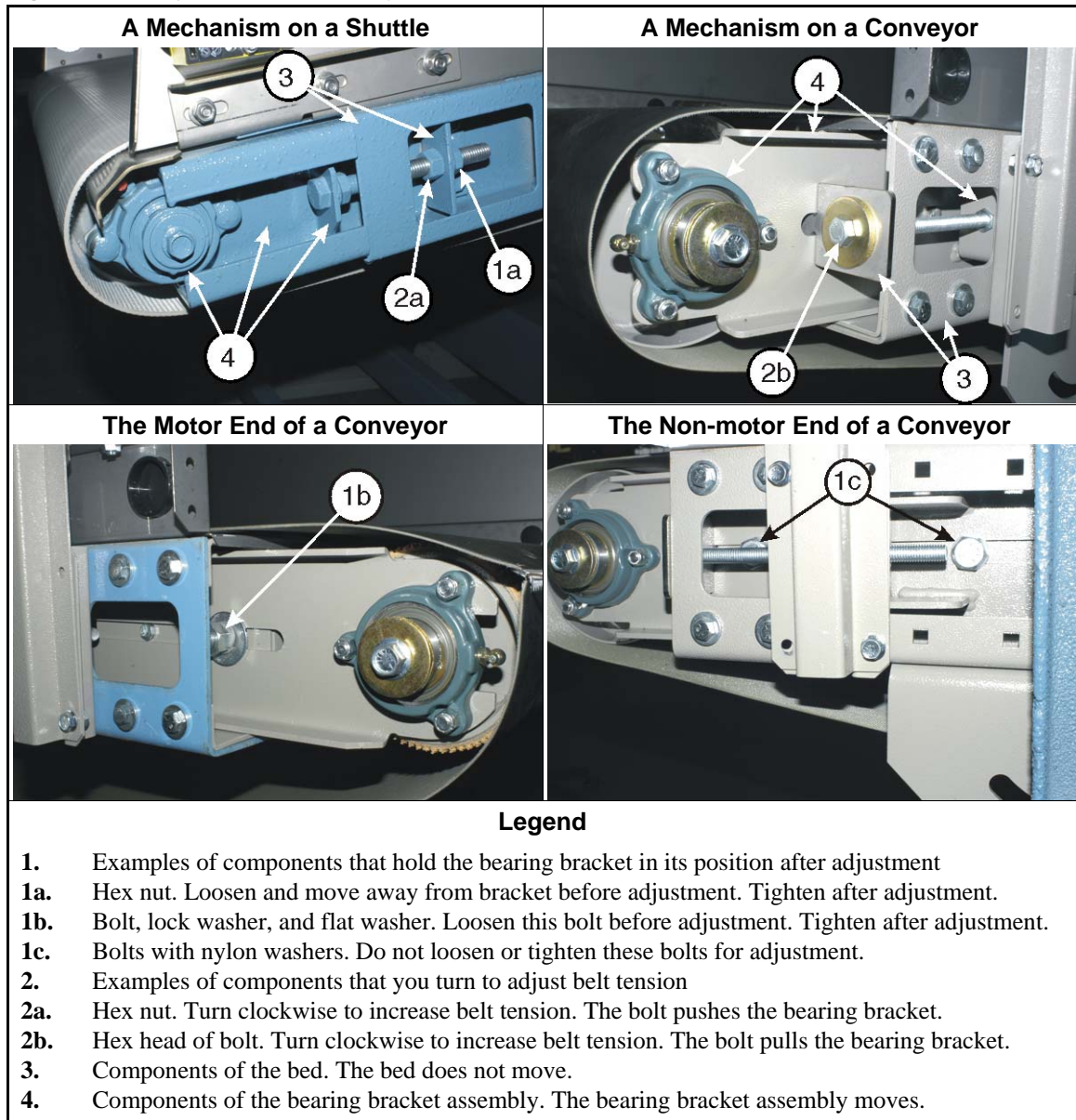
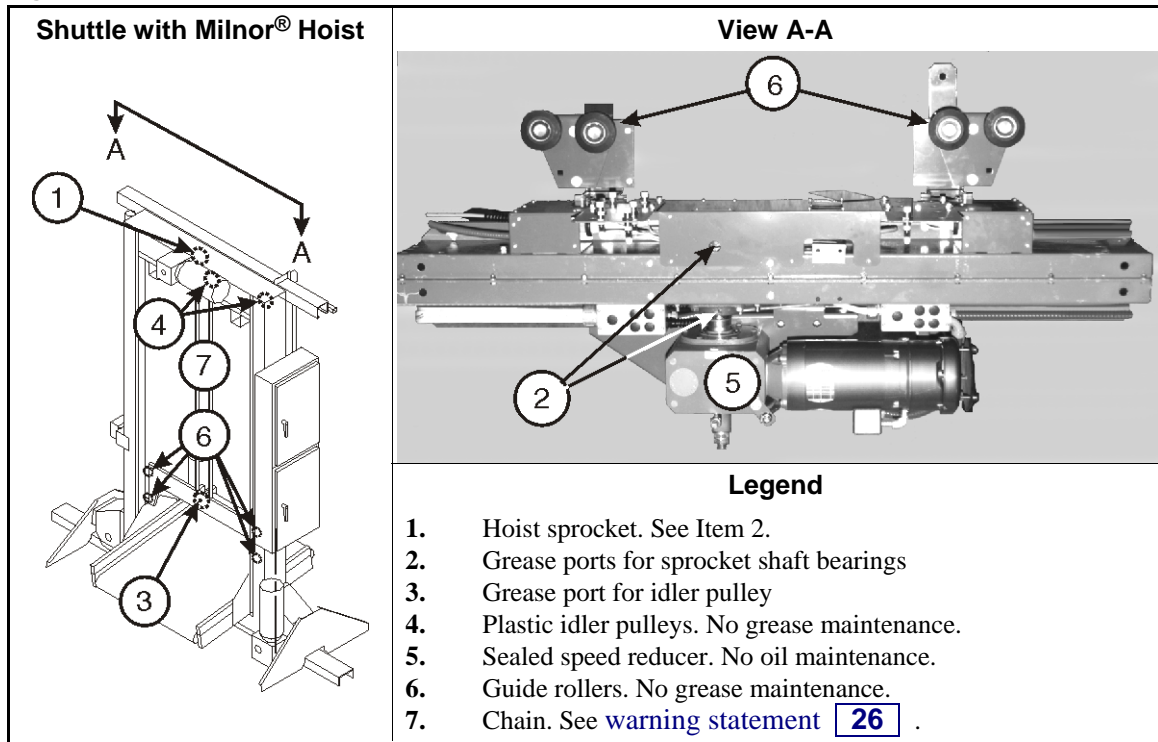

Figure 9: Elevator Maintenance—Milnor® Hoist



WARNING 26: Crush hazard—The chain will fall out of the machine if you continue to operate the hoist motor after the bed is at the bottom of the machine.

- Make sure all personnel are away from the machine when you manually operate it.
- When you lower the bed to apply lubricant to the chain, stop when the bed is at the bottom of the machine.

Supplement 6

Elevator Malfunctions That You Can Possibly Correct Immediately



WARNING 27: Crush and fall hazards—

- Use a suitable, self-supporting platform when you do work on shuttle components.
- Do not stand or ride on the shuttle bed. Use the safety pins.
- Keep away from the machine when it operates manually or automatically.

Given here are conditions caused by mechanical malfunctions that you can possibly correct without replacement parts. Speak to your dealer or Milnor if you cannot identify the cause or correct the condition. Speak to your dealer or Milnor if you do not have safe equipment to do maintenance at the necessary height.

bed assembly goes to top limit of travel and stops—On machines with the Milnor hoist, a taut chain error occurs. On machines with the Demag hoist, no error occurs, but the machine can stop operation. **Cause:** The controller looked for a level (load or discharge) and the proximity switch for that level did not find a target. **Components to examine:** It is possible that the proximity switch and target are not aligned. See [Figure 10](#). When the switch is behind the target, the correct clearance is approximately 5/16 inch (8 mm). If the clearance is different each time that the photoeye goes behind the target, examine the bed assembly and frame for damage. The bed assembly can have too much side-to-side movement in the frame. See the condition that follows. **Recovery:** See the data in the dryer/shuttle operator

guide for the taut chain error.

bed assembly stops in the middle of travel—On machines with the Milnor hoist, a taut chain error occurs. On machines with the Demag hoist, the slip clutch disengages the hoist motor when the chain tension is more than the hoist maximum capacity. **Cause:** The bed assembly twisted in the frame. **Components to examine:** One or more components of the bed assembly (example: a guide roller) are damaged or bent. **Recovery:** See the data in the dryer/shuttle operator guide for the taut chain error.

The bed goes down by gravity—This condition usually prevents transfer which will cause an error that stops operation. **Cause:** Too much weight is on the bed. This condition can also occur if the brake pads in the hoist motor are worn (usually as a result of too heavy loads). **Components to examine:** Load weight. If the bed goes down with the correct load weight, it is necessary to adjust or replace the brake pads. Speak to your dealer or Milnor. This is not routine maintenance. **Recovery:** See the data in the dryer/shuttle operator guide for the error that occurred.

Figure 10: Elevator Proximity Switches and Targets

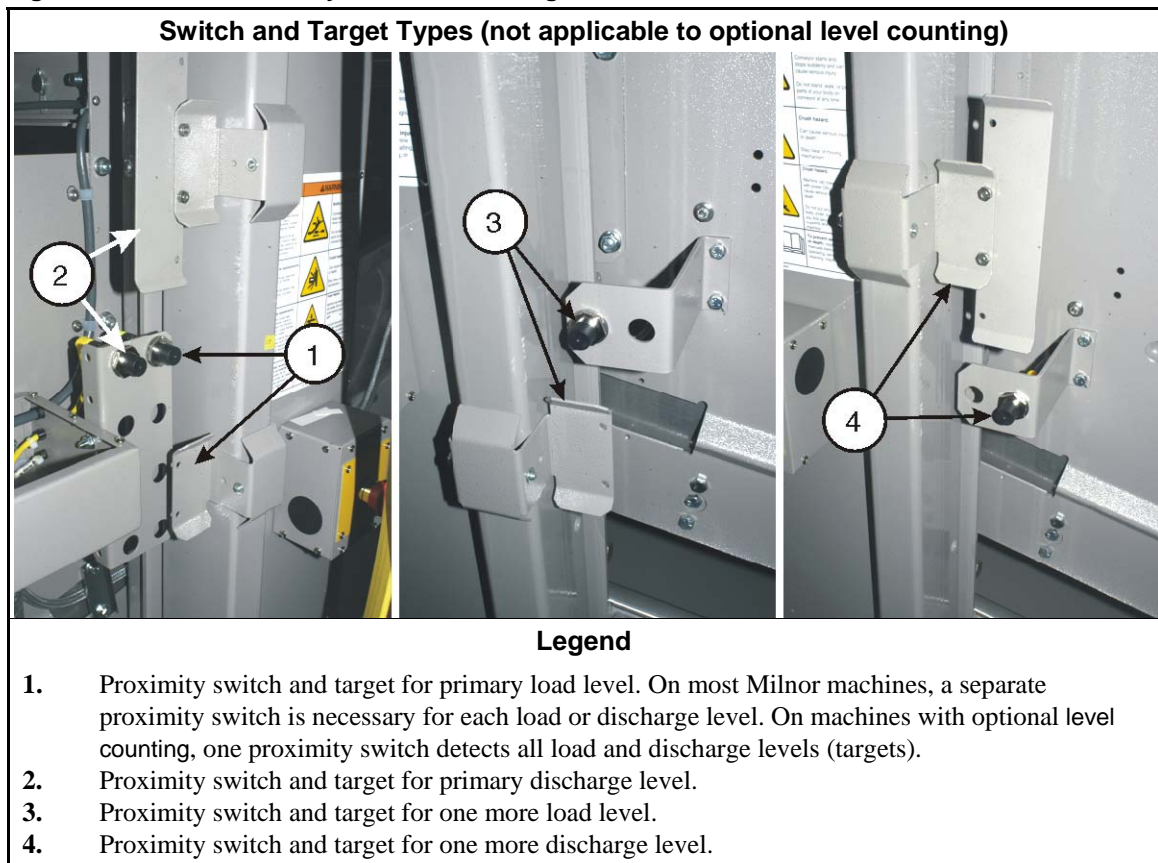
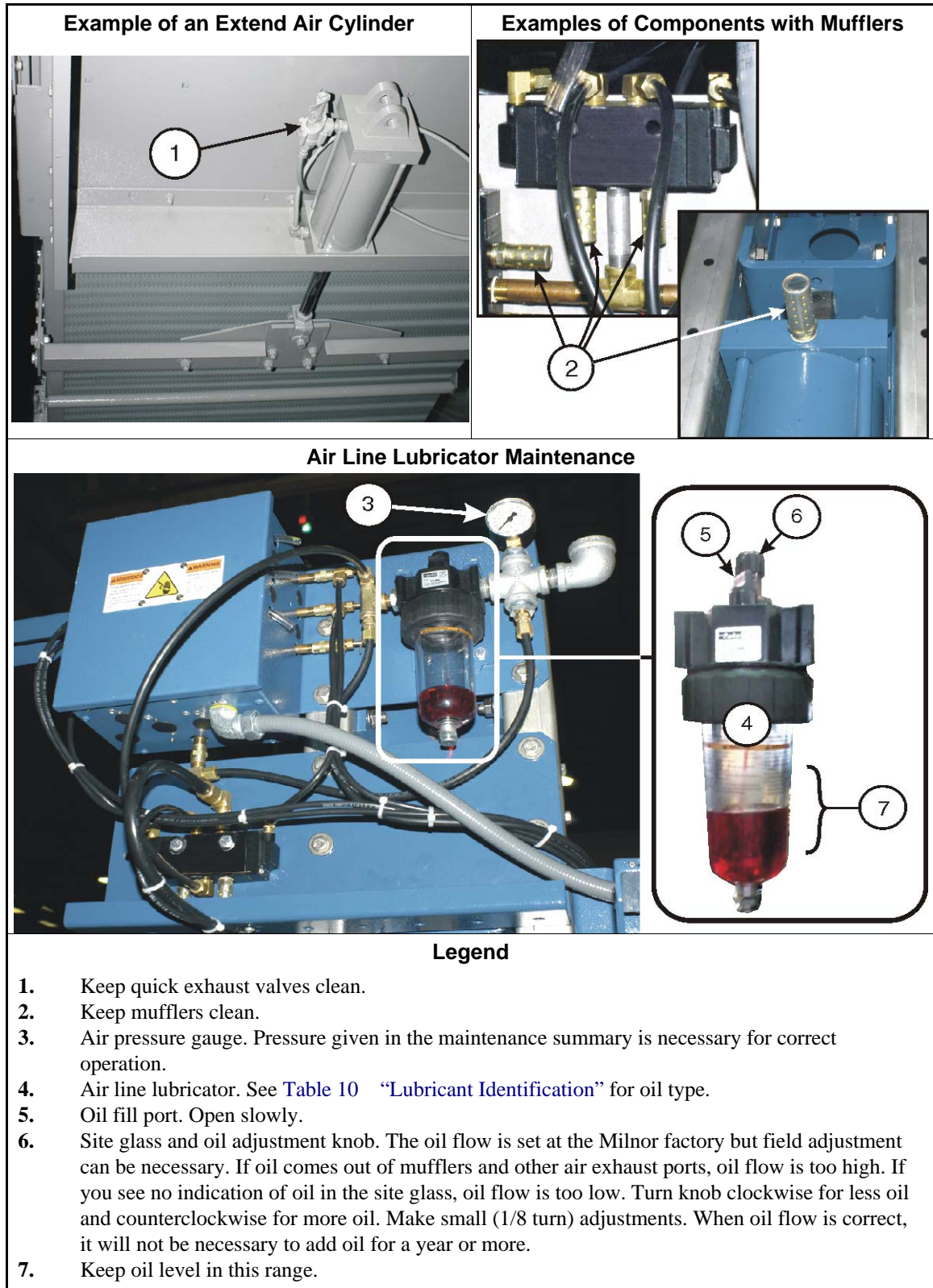

Figure 11: Compressed Air Mechanisms on Wet Goods Shuttles and Some Loose Goods Shuttles (see Supplement 2).



— End of BIUUM09 —