

Published Manual Number/ECN: MKWFBH01U1/2025075A

- Publishing System: TPAS2
- Access date: 02/13/2025
- Document ECNs: Latest



# 48040F7B & F7D



PELLERIN MILNOR CORPORATION POST OFFICE BOX 400, KENNER, LOUISIANA 70063-0400, U.S.A.



# MKWFBH01U1/25075A

## 1. English

Maintenance Guide - Washer-extractor, Bottom-suspended,  
Pneumatic Tilt, \_F7B, \_F7D

MKWFBH01EN/2021444

## 2. Français

Guide de maintenance - Laveuse-essoreuse, suspendue par  
le bas, inclinaison pneumatique, \_F7B, \_F7D

MKWFBH01FR/2021444



English

1





Manual Number: MKWFBH01EN  
Edition (ECN): 2021444

# Maintenance Guide

## Washer-extractor, Bottom-suspended, Pneumatic Tilt, \_F7B, \_F7D



## Contents

1 Machine Description and Identification .....	4
1.1 About This Manual and Your Milnor® Machine .....	4
1.1.1 Description .....	4
1.1.2 Machine Identification.....	4
• Machine Data Plate .....	4
2 Safety.....	5
2.1 Tilting Washer Extractors .....	5
2.1.1 Safety Alert Messages—Internal Electrical and Mechanical Hazards.....	5
2.1.2 Safety Alert Messages—Cylinder and Processing Hazards.....	6
2.1.3 Safety Alert Messages—Unsafe Conditions .....	7
2.1.3.1 Damage and Malfunction Hazards .....	7
2.1.3.1.1 Hazards Resulting from Inoperative Safety Devices.....	7
2.1.3.1.2 Hazards Resulting from Damaged Mechanical Devices .....	8
2.1.3.2 Careless Use Hazards .....	8
2.1.3.2.1 Careless Operation Hazards—Vital Information for Operator Personnel (see also operator hazards throughout manual) .....	8
2.1.3.2.2 Careless Servicing Hazards—Vital Information for Service Personnel (see also service hazards throughout manuals).....	9
2.2 Use the Red Safety Supports for Maintenance — 48040F7B, 48040F7D .....	10
2.2.1 What Safety Supports are Provided and Why .....	10
2.2.2 How To Deploy the Safety Stands.....	10
2.3 Prevent Damage from Chemical Supplies and Chemical Systems .....	11
2.3.1 How Chemical Supplies Can Cause Damage.....	11
• Dangerous Chemical Supplies and Wash Formulas.....	11
• Incorrect Configuration or Connection of Equipment .....	11
2.3.2 Equipment and Procedures That Can Prevent Damage.....	13
• Use the chemical manifold supplied. ....	13
• Close the line.....	14
• Do not let a vacuum occur.....	14
• Flush the chemical tube with water. ....	14
• Put the chemical tube fully below the inlet.....	14
• Prevent leaks. ....	14
3 Routine Maintenance.....	15
3.1 Routine Maintenance .....	15
3.1.1 Maintenance Summary .....	15
3.1.1.1 Guards and Related Components .....	16
3.1.1.2 Filters, Screens, and Sensitive Components.....	16
3.1.1.3 Fluid Containers .....	17
3.1.1.4 Components that Become Worn.....	17
3.1.1.5 Bearings and Bushings .....	18
3.1.1.6 Motor Grease Schedule .....	18
3.1.1.7 Mechanisms and Settings .....	18
3.1.2 How To Remove Contamination .....	19
3.1.3 Lubricant Identification .....	20
3.1.4 Grease Gun Procedures .....	21
3.1.5 Procedures for Bearing Components Connected to a Grease Plate.....	21



3.1.6	Procedures for Motors .....	22
3.1.7	How To Show the Maintenance On a Calendar .....	24
3.2	Maintenance Components—Machines and Controls Group .....	25
3.2.1	How to Examine V-belts and Pulleys .....	25
3.2.2	Inverters .....	27
3.2.3	Chemical Devices .....	27
3.2.4	Water and Steam Devices .....	28
3.2.5	How to Examine Compressed Air Mechanisms.....	30
3.2.6	Photoeyes and Proximity Switches .....	33
3.2.7	How to Do a Test of Emergency Stop Mechanisms.....	33
3.3	Maintenance Components—Large Extractors .....	35
3.3.1	Lubricant Maintenance for Grease-filled Drive Bearings.....	35
3.3.2	Lubricant Maintenance for Non-drive Components.....	35
3.3.3	How to Do a Test of the Mechanical Brake .....	36
3.3.4	About the Shock Absorbers.....	37

## Figures

Figure 1	Machine Data Plate .....	4
Figure 2	Incorrect Configurations That Let the Chemical Supply Go In the Machine by a Siphon.....	12
Figure 3	Incorrect Configurations That Let the Chemical Supply Go In the Machine by Gravity.....	13
Figure 4	Examples of Manifolds for Chemical Tubes. Your equipment can look different.....	13
Figure 5	A Configuration that Prevents Flow in the Machine When the Pump is Off (if the chemical tube and tank have no pressure) .....	14
Figure 6	Motor Grease Maintenance Conditions .....	23
Figure 7	Belt and Pulley Conditions To Look For .....	25
Figure 8	How to Adjust Belt Tension On a Machine That Uses Spring Tension .....	26
Figure 9	Electric Box and Inverter. These are examples. Your machine can look different.....	27
Figure 10	Chemical Inlet Manifolds for Chemical Pump Systems. See caution statement below. These are examples. Your machine can look different. ....	28
Figure 11	Soap Chute and Optional 5-compartment Supply Injector. These are examples. Your machine can look different. ....	28
Figure 12	Air Tube for the Water Level Sensor. These are examples. Your machine can look different. ....	29
Figure 13	Water Pressure Regulator for Chemical Flush. These are examples. Your machine can look different.....	29
Figure 14	Steam Inlet Strainer. These are examples. Your machine can look different.....	30
Figure 15	Compressed Air Inlet Strainers. These are examples. Your machine can look different.....	30
Figure 16	Self-purging Air Line Filter to Remove Moisture and Other Contamination. These are examples. Your machine can look different.....	31
Figure 17	Compressed Air Mechanisms These are examples. Your machine can look different. ....	32

Figure 18	Speed Sensor (photoeye) on Some Machines.....	33
Figure 19	Proximity Switches These are examples. Your machine can look different.....	33
Figure 20	Grease Ports for Grease-only Bearing Assembly .....	35
Figure 21	Grease ports for Door—Open Pocket Models. These are examples. Your machine can look different.....	35
Figure 22	Other Routine Maintenance Items on Each Side of 48040F7_ Washer- extractor Models .....	36
Figure 23	Example of Disk Brake. Your machine can look different. ....	37
Figure 24	Suspension Components on Each Side of Rubber Spring-resting Wash- er-extractor (see 3.3.4 About the Shock Absorberspage 37) .....	38

### Tables

Table 1	Guards and Related Components .....	16
Table 2	Filters, Screens, and Sensitive Components .....	16
Table 3	Fluid Containers .....	17
Table 4	Components that Become Worn .....	17
Table 5	Bearings and Bushings .....	18
Table 6	Motor Grease Schedule .....	18
Table 7	Mechanisms and Settings .....	19
Table 8	Contamination Types, Cleaning Agents, and Procedures .....	19
Table 9	Lubricant Identification .....	20
Table 10	Motor Grease Intervals and Quantities .....	24
Table 11	Where to Put Marks On a Calendar .....	25

# 1 Machine Description and Identification

BNUUUF02 / 2021442

BNUUUF02 0000369288 A.6 10/25/21 9:27 AM Released

## 1.1 About This Manual and Your Milnor® Machine

BNUUUF02.C01 0000369287 A.5 A.6 A.9 10/14/21 8:55 AM Released

This manual applies to two or more models that share the mechanical characteristics stated below. If you received this manual with your machine, your machine is one of the applicable models. However, before using this manual, verify that your machine does have these characteristics.

### 1.1.1 Description

BNUUUF02.C02 0000369286 A.5 A.6 A.35 11/16/21 8:39 AM Released

Washer-extractors wash linen using water and non-volatile chemicals then remove excess water by centrifugal force. This washer-extractor is the mechanical type described below.

**\_F7B, \_F7D** A machine represented by one of these partial model numbers is a bottom-suspended (rubber springs), pneumatic tilt-to-load and unload washer-extractor with grease bearings and a mechanical (disc) brake. The capacity is 275 lb.(125 kg).

### 1.1.2 Machine Identification

BNUUUF02.R01 0000369284 A.5 A.6 A.9 10/25/21 9:22 AM Released

**Machine Data Plate** — Find the model number and other data for your machine on the machine data plate affixed to the machine and described below.

Figure 1. Machine Data Plate

View of Data Plate (English text shown)	Legend
	<p><b>Legend</b></p> <ol style="list-style-type: none"> <li>1. Model number.</li> <li>2. Data that uniquely identifies your machine. Refer to this data when you speak with your dealer or Milnor® about your machine.</li> <li>3. Cylinder maximum rotation speed in revolutions per minute</li> <li>4. Cylinder volume in the units of measure shown</li> <li>5. Piped utility requirements</li> <li>6. Electrical requirements</li> </ol>

# 2 Safety

BNWHTS08 / 2021243

BNWHTS08 0000349892 A.2 6/8/21 3:00 PM Released

## 2.1 Tilting Washer Extractors

BNWHTS08.C01 0000349891 A.5 A.2 6/8/21 3:00 PM Released

### 2.1.1 Safety Alert Messages—Internal Electrical and Mechanical Hazards

BNWHTS01.C03 0000235031 A.5 A.2 B.1 1/20/20 12:08 PM Released

The following are instructions about hazards inside the machine and in electrical enclosures.



**WARNING: Electrocutation and Electrical Burn Hazards** — Contact with electric power can kill or seriously injure you. Electric power is present inside the cabinetry unless the main machine power disconnect is off.



- ▶ Do not unlock or open electric box doors.
- ▶ Do not remove guards, covers, or panels.
- ▶ Do not reach into the machine housing or frame.
- ▶ Keep yourself and others off of machine.
- ▶ Know the location of the main machine disconnect and use it in an emergency to remove all electric power from the machine.



**WARNING: Entangle and Crush Hazards** — Contact with moving components normally isolated by guards, covers, and panels, can entangle and crush your limbs. These components move automatically.



- ▶ Do not remove guards, covers, or panels.
- ▶ Do not reach into the machine housing or frame.
- ▶ Keep yourself and others off of machine.
- ▶ Know the location of all emergency stop switches, pull cords, and/or kick plates and use them in an emergency to stop machine motion.



**WARNING: Crush Hazards** — Tilting machines only—The machine housing will crush your body or limbs if it descends or falls while you are under it. Housing can descend with power off or on. Manual operation of tilting valves overrides safety interlocks. Improper operation of manual tilting valves may cause the housing to descend.



- ▶ Do not remove guards, covers, or panels.
- ▶ Do not reach into the machine housing or frame.

## 2.1.2 Safety Alert Messages—Cylinder and Processing Hazards

BNWHTS03.C03 0000235025 A.5 A.2 A.3 1/2/20 2:19 PM Released

The following are instructions about hazards related to the cylinder and laundering process.



**DANGER: Entangle and Sever Hazards** — Contact with goods being processed can cause the goods to wrap around your body or limbs and dismember you. The goods are normally isolated by the locked cylinder door.



- ▶ Do not attempt to open the door or reach into the cylinder until the cylinder is stopped.
- ▶ Do not touch goods inside or hanging partially outside the turning cylinder.
- ▶ Do not operate the machine with a malfunctioning door interlock.
- ▶ Open pocket machines only—Do not jog the cylinder and pull the goods at the same time.
- ▶ Open pocket machines only—Keep yourself and others clear of cylinder and goods during jogging operation.
- ▶ Do not operate the machine with malfunctioning two-hand manual controls.
- ▶ Know the location of all emergency stop switches, pull cords, and/or kick plates and use them in an emergency to stop machine motion.
- ▶ Know the location of the main machine disconnect and use it in an emergency to remove all electric power from the machine.



**WARNING: Crush Hazards** — Contact with the turning cylinder can crush your limbs. The cylinder will repel any object you try to stop it with, possibly causing the object to strike or stab you. The turning cylinder is normally isolated by the locked cylinder door.



- ▶ Do not attempt to open the door or reach into the cylinder until the cylinder is stopped.
- ▶ Do not place any object in the turning cylinder.
- ▶ Do not operate the machine with a malfunctioning door interlock.
- ▶ Open pocket machines only—Keep yourself and others clear of cylinder and goods during jogging operation.
- ▶ Do not operate the machine with malfunctioning two-hand manual controls.



**WARNING: Confined Space Hazards** — Confinement in the cylinder can kill or injure you. Hazards include but are not limited to panic, burns, poisoning, suffocation, heat prostration, biological contamination, electrocution, and crushing.



- ▶ Do not attempt unauthorized servicing, repairs, or modification.



**WARNING: Explosion and Fire Hazards** — Flammable substances can explode or ignite in the cylinder, drain trough, or sewer. The machine is designed for washing with water, not any other solvent. Processing can cause solvent-containing goods to give off flammable vapors.



- ▶ Do not use flammable solvents in processing.
- ▶ Do not process goods containing flammable substances. Consult with your local fire department/public safety office and all insurance providers.

## 2.1.3 Safety Alert Messages—Unsafe Conditions

BNWHTS04.C01 0000235024 A.5 A.2 1/2/20 2:19 PM Released

### 2.1.3.1 Damage and Malfunction Hazards

BNWHTS04.C02 0000235048 A.5 A.2 1/2/20 2:19 PM Released

#### 2.1.3.1.1 Hazards Resulting from Inoperative Safety Devices

BNWHTS04.C03 0000235047 A.5 A.2 A.3 1/2/20 2:19 PM Released



**DANGER: Entangle and Sever Hazards** — Cylinder door interlock—Operating the machine with a malfunctioning door interlock can permit opening the door when the cylinder is turning and/or starting the cycle with the door open, exposing the turning cylinder.



- ▶ Do not operate the machine with any evidence of damage or malfunction.



**WARNING: Multiple Hazards** — Operating the machine with an inoperative safety device can kill or injure personnel, damage or destroy the machine, damage property, and/or void the warranty.

- ▶ Do not tamper with or disable any safety device or operate the machine with a malfunctioning safety device. Request authorized service.



**WARNING: Electrocution and Electrical Burn Hazards** — Electric box doors—Operating the machine with any electric box door unlocked can expose high voltage conductors inside the box.

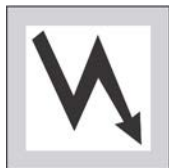

- ▶ Do not unlock or open electric box doors.



**WARNING: Entangle and Crush Hazards** — Guards, covers, and panels—Operating the machine with any guard, cover, or panel removed exposes moving components.



- ▶ Do not remove guards, covers, or panels.



**WARNING: Crush Hazards** — Down limit switches (machines with front and rear tilt cylinders)—Failure of both front or both rear limit switches allows the seated tilt wheels on a tilted machine to lift from their cradles. The housing will fall and lunge forward or rearward.

- ▶ Do not operate the machine with any evidence of damage or malfunction.

### 2.1.3.1.2 Hazards Resulting from Damaged Mechanical Devices

BNWHTS04.C04 0000235046 A.5 A.2 A.3 1/2/20 2:19 PM Released



**WARNING: Multiple Hazards** — Operating a damaged machine can kill or injure personnel, further damage or destroy the machine, damage property, and/or void the warranty.

- ▶ Do not operate a damaged or malfunctioning machine. Request authorized service.



**WARNING: Explosion Hazards** — Cylinder—A damaged cylinder can rip apart during extraction, puncturing the shell and discharging metal fragments at high speed.



- ▶ Do not operate the machine with any evidence of damage or malfunction.



**WARNING: Explosion Hazards** — Clutch and speed switch (multiple motor machines)—A damaged clutch or speed switch can permit the low speed motor to engage during extract. This will over-speed the motor and pulleys and can cause them to rip apart, discharging metal fragments at high speed.



- ▶ Stop the machine immediately if any of these conditions occur: • abnormal whining sound during extract • skidding sound as extract ends • clutches remain engaged or re-engage during extract

### 2.1.3.2 Careless Use Hazards

BNWHTS04.C05 0000235045 A.5 A.2 1/2/20 2:19 PM Released

#### 2.1.3.2.1 Careless Operation Hazards—Vital Information for Operator Personnel (see also operator hazards throughout manual)

BNWHTS04.C06 0000235044 A.5 A.2 A.3 1/2/20 2:19 PM Released



**WARNING: Multiple Hazards** — Careless operator actions can kill or injure personnel, damage or destroy the machine, damage property, and/or void the warranty.

- ▶ Do not tamper with or disable any safety device or operate the machine with a malfunctioning safety device. Request authorized service.
- ▶ Do not operate a damaged or malfunctioning machine. Request authorized service.
- ▶ Do not attempt unauthorized servicing, repairs, or modification.
- ▶ Do not use the machine in any manner contrary to the factory instructions.
- ▶ Use the machine only for its customary and intended purpose.
- ▶ Understand the consequences of operating manually.

### 2.1.3.2.2 Careless Servicing Hazards—Vital Information for Service Personnel (see also service hazards throughout manuals)

BNWHTS04.C07 0000235043 A.5 A.2 A.3 1/2/20 2:19 PM Released



**WARNING: Electrocution and Electrical Burn Hazards** — Contact with electric power can kill or seriously injure you. Electric power is present inside the cabinetry unless the main machine power disconnect is off.

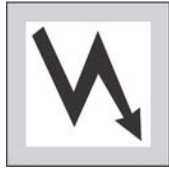

- ▶ Do not service the machine unless qualified and authorized. You must clearly understand the hazards and how to avoid them.
- ▶ Abide by the current OSHA lockout/tagout standard when lockout/tagout is called for in the service instructions. Outside the USA, abide by the OSHA standard in the absence of any other overriding standard.



**WARNING: Entangle and Crush Hazards** — Contact with moving components normally isolated by guards, covers, and panels, can entangle and crush your limbs. These components move automatically.



- ▶ Do not service the machine unless qualified and authorized. You must clearly understand the hazards and how to avoid them.
- ▶ Abide by the current OSHA lockout/tagout standard when lockout/tagout is called for in the service instructions. Outside the USA, abide by the OSHA standard in the absence of any other overriding standard.



**WARNING: Crush Hazards** — Tilting machines only—The machine housing will crush your body or limbs if it descends or falls while you are under it. Housing can descend with power off or on. Manual operation of tilting valves overrides safety interlocks. Improper operation of manual tilting valves may cause the housing to descend.



- ▶ Secure both red safety supports in accordance with the instructions furnished, then lock out and tag out power at the main machine disconnect before working under the tilted machine.
- ▶ Do not operate the manual tilt valves with anyone under the machine.
- ▶ Do not operate the tilt controls with anyone under the machine.



**WARNING: Crush Hazards** — Tilting machines with front and rear tilt cylinders—The housing will fall and lunge forward or rearward if the tilt wheels on the non-tilted end lift out of their cradles, even with safety supports in place.

- ▶ Understand the consequences of operating manually.



**WARNING: Confined Space Hazards** — Confinement in the cylinder can kill or injure you. Hazards include but are not limited to panic, burns, poisoning, suffocation, heat prostration, biological contamination, electrocution, and crushing.



- ▶ Do not enter the cylinder until it has been thoroughly purged, flushed, drained, cooled, and immobilized.



## 2.2 Use the Red Safety Supports for Maintenance — 48040F7B, 48040F7D

BNWFBH01.C02 0000373627 A.5 A.2 8/11/21 11:34 AM Released

### 2.2.1 What Safety Supports are Provided and Why

BNWFBH01.C01 0000373439 A.5 A.6 8/18/21 1:20 PM Released

These machines are provided with two safety stands. After the housing is tilted forward or rearward, as needed, the stands are placed under the raised, rear or front tilt wheels. The safety stand(s) provide protection against the un-powered descent of the housing during maintenance in the event of a leak in the pneumatic tilt system. Such a condition can cause the housing to fall quickly. Use the safety support(s) whenever the maintenance to be performed requires you to place any part of your body in or near the path of the vertically moving portion of the machine.



**WARNING:** **Incorrect use of the safety supports** — can cause the machine to descend and crush you.



- ▶ Never work near the path of the vertically moving portion of the machine unless the safety supports are deployed and power is removed from the machine.
- ▶ Where a pair of safety supports is provided, always use both supports.
- ▶ Maintain the safety support(s) in good condition.
- ▶ When not in use, stow the safety support(s) in the location(s) provided on the machine or in a convenient, designated location.

### 2.2.2 How To Deploy the Safety Stands

BNWFBH01.T01 0000373438 A.5 A.7 8/19/21 11:44 AM Released

1. Use the controls to tilt the machine up as in normal operation.
2. See the illustration at right. Put each safety stand on its mounting plate on the tilt base so it is seated correctly. Reach from the near side of the machine.
3. Use the controls to carefully lower the housing just until it is resting on the stand(s).
4. Remove electric power from the machine.

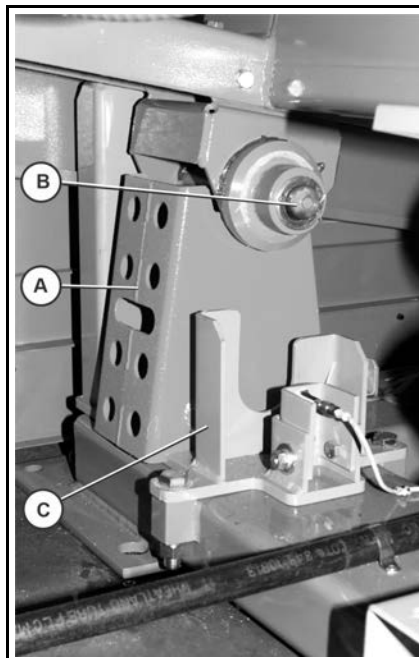

Legend	
A . . .	<b>Safety Stand.</b> Used in two front locations or two rear locations.
B . . .	Tilt wheel
C . . .	Cradle

## 2.3 Prevent Damage from Chemical Supplies and Chemical Systems

BNUUUR02.C01 0000160549 A.5 E.3 B.3 1/2/20 2:14 PM Released

All Milnor® washer-extractors and CBW® tunnel washers use stainless steel with the ANSI 304 specification. This material gives good performance when chemical supplies are correctly applied. If chemical supplies are incorrectly applied, this material can be damaged. The damage can be very bad and it can occur quickly.

Chemical supply companies usually:

- supply chemical pump systems that put the supplies in the machine,
- connect the chemical pump system to the machine,
- write wash formulas that control the chemical concentrations.

The company that does these procedures must make sure that these procedures do not cause damage. **Pellerin Milnor Corporation accepts no responsibility for chemical damage to the machines it makes or to the goods in a machine.**

### 2.3.1 How Chemical Supplies Can Cause Damage

BNUUUR02.R01 0000160548 A.5 E.3 B.5 10/1/21 11:24 AM Released

**Dangerous Chemical Supplies and Wash Formulas** — Some examples that can cause damage are:

- a very high concentration of chlorine bleach,
- a mixture of acid sour and hypo chlorite,
- chemical supplies (examples: chlorine bleach, hydrofluosilicic acid) that stay on the stainless steel because they are not quickly flushed with water.

The book “Textile Laundering Technology” by Charles L. Riggs gives data about correct chemical supplies and formulas.

**Incorrect Configuration or Connection of Equipment** — Many chemical systems:

- do not prevent a vacuum in the chemical tube (for example, with a vacuum breaker) when the pump is off,
- do not prevent flow (for example, with a valve) where the chemical tube goes in the machine.

Damage will occur if a chemical supply can go in the machine when the chemical system is off. Some configurations of components can let the chemical supplies go in the machine by a siphon (Figure 2, page 12). Some can let chemical supplies go in the machine by gravity (Figure 3, page 13).

**Figure 2. Incorrect Configurations That Let the Chemical Supply Go In the Machine by a Siphon**

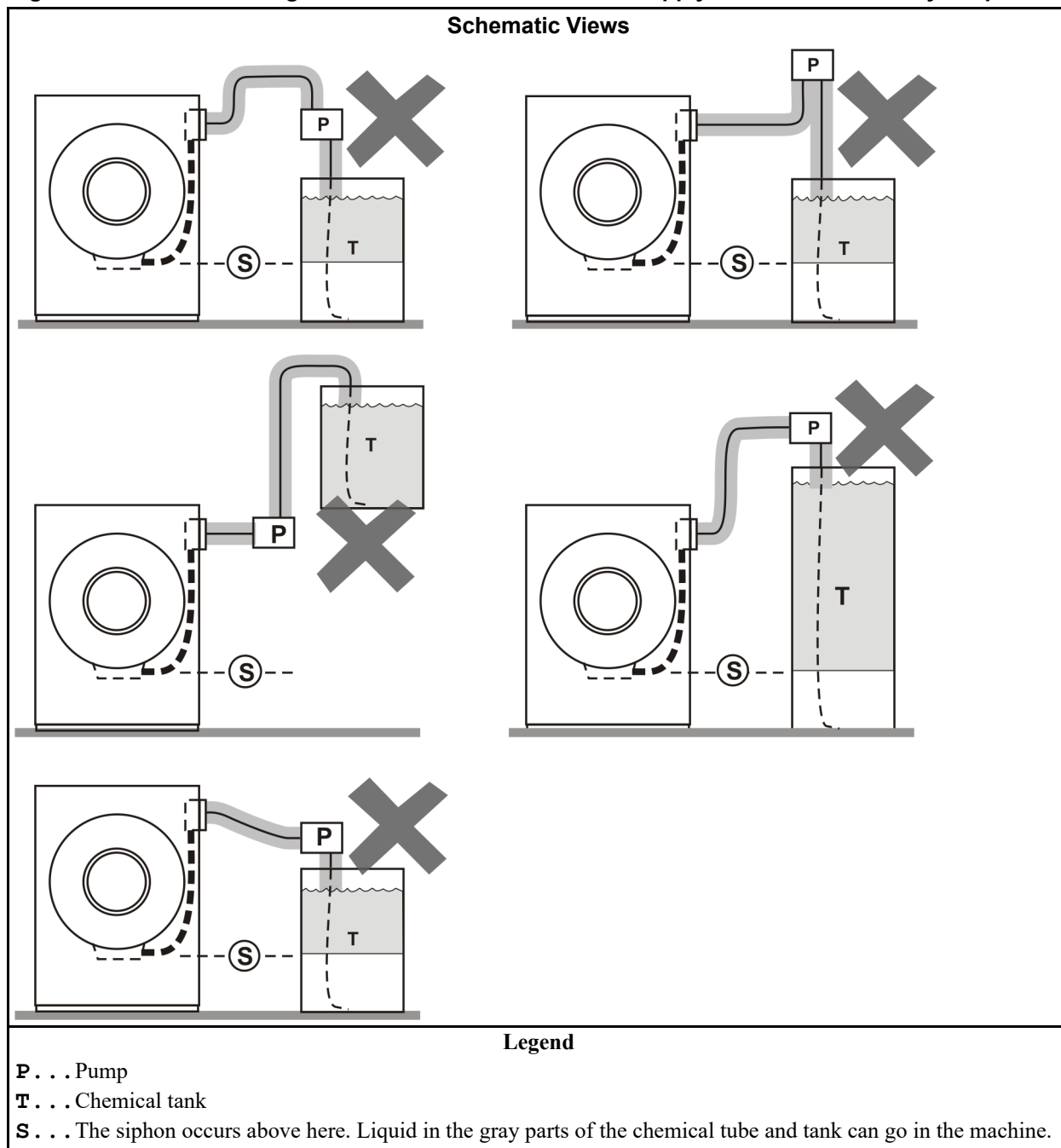

**Figure 3. Incorrect Configurations That Let the Chemical Supply Go In the Machine by Gravity**

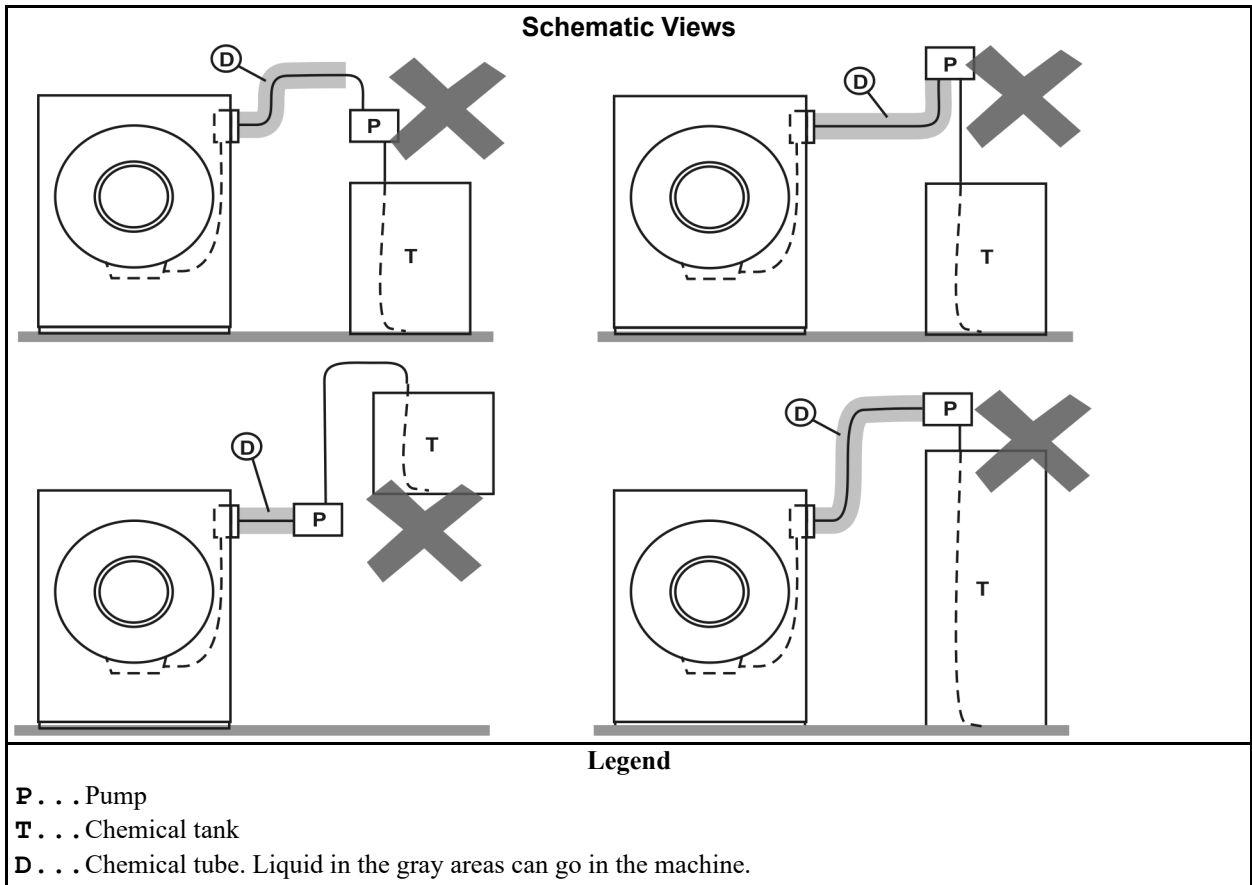

## 2.3.2 Equipment and Procedures That Can Prevent Damage

BNUUUR02.R02 0000160545 A.5 E.3 B.3 1/2/20 2:14 PM Released

**Use the chemical manifold supplied.** — There is a manifold on the machine to attach chemical tubes from a chemical pump system. The manifold has a source of water to flush the chemical supplies with water.

**Figure 4. Examples of Manifolds for Chemical Tubes. Your equipment can look different.**

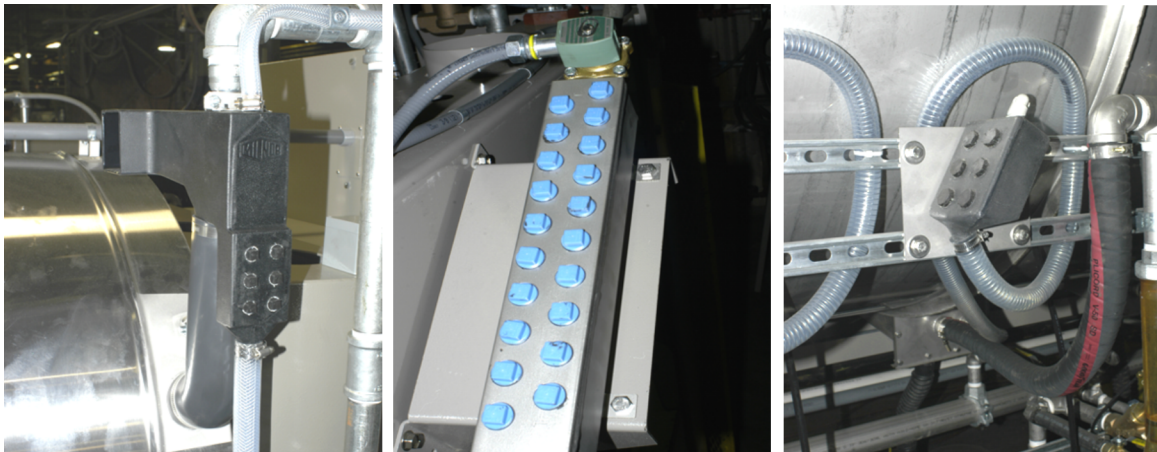

**Close the line.** — If the pump does not always close the line when it is off, use a shutoff valve to do this.

**Do not let a vacuum occur.** — Supply a vacuum breaker in the chemical line that is higher than the full level of the tank.

**Flush the chemical tube with water.** — If the liquid that stays in the tube between the pump and the machine can flow in the machine, flush the tube with water after the pump stops.

**Put the chemical tube fully below the inlet.** — It is also necessary that there is no pressure in the chemical tube or tank when the system is off.

**Figure 5. A Configuration that Prevents Flow in the Machine When the Pump is Off (if the chemical tube and tank have no pressure)**

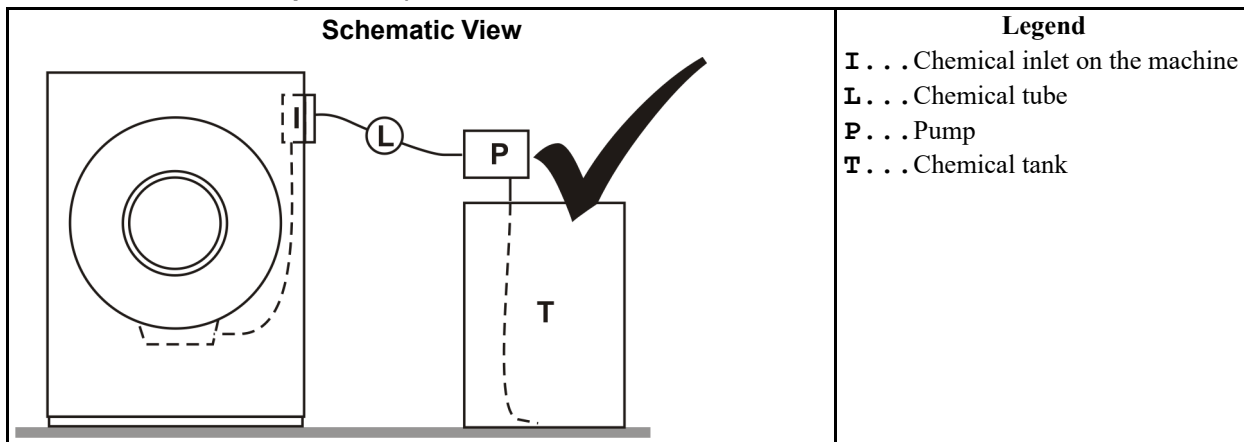

**Prevent leaks.** — When you do maintenance on the chemical pump system:

- Use the correct components.
- Make sure that all connections are the correct fit.
- Make sure that all connections are tight.

# 3 Routine Maintenance

BNUUUH01 / 2021444

BNUUUH01 0000333813 A.26 11/4/21 9:18 AM Released

## 3.1 Routine Maintenance

BIUUUM09.C01 A.5 A.26 Released

Do the maintenance in [Section 3.1.1 : Maintenance Summary, page 15](#) to make sure that the machine is safe, keeps the warranty, and operates correctly. This will also decrease repair work and unwanted shutdowns. Speak to your dealer or the Milnor® Service department if repairs are necessary.



**WARNING:** Mechanisms — can pull in and mutilate body parts.



- ▶ Do not service the machine unless qualified and authorized. You must clearly understand the hazards and how to avoid them.
- ▶ Do not service the machine with power on except when explicitly called for in the service instructions. Use extreme care when working near moving components.
- ▶ Replace guards and covers that you remove for maintenance.

If you use software to keep the maintenance schedule for your plant, add the items in the following maintenance summary to that schedule. If not, you can put marks on a calendar that work with the tables in the maintenance summary. See [Section 3.1.7 : How To Show the Maintenance On a Calendar, page 24](#)

### 3.1.1 Maintenance Summary

BNUUUH01.R02 0000334004 A.5 A.26 A.35 10/25/21 1:20 PM Released

Each of the following sections is for a type of maintenance. For example, the section “Guards and Related Components” says “Examine these items. If an item is damaged, missing, or has the wrong setting, correct this discrepancy immediately to prevent injury.” A table in each section identifies the applicable items and the frequency. The “More Data” column gives special instructions if necessary.

\* If the machine operates more than 12 hours each day, do the “day” items two times each day. Do the other items at the given hours or on the days that you show on a calendar (see Section 1). **Do all items in all sections for the maintenance intervals that apply (for example, day, 40 to 60 hours, and 200 hours).**



**TIP:** The maintenance summary has many links to the sections that follow the summary. These sections give more information about the maintenance items. After you learn this information, it is only necessary to look at the summary to do the maintenance.

### 3.1.1.1 Guards and Related Components

BNUUUH01.R09 0000399322 A.5 A.26 A.9 11/4/21 11:27 AM Released

Examine these items. If an item is damaged, missing, or has the wrong setting, correct this discrepancy immediately to prevent injury.

**Table 1. Guards and Related Components**

Mark						Do this each	Component	More Data
1	2	3	4	5	6			
x						day*	guards, covers	Speak to your dealer or Milnor for replacement components.
x						day*	safety placards	
		x				200 hours	fasteners	Fasteners must be tight.
x						day*	safety stands, bars or pins (painted red)	Speak to your dealer or Milnor for replacement components. See the section “Use the Red Safety Supports for Maintenance...” in the Safety chapter.
		x				200 hours	anchor bolts and grout	Grout must be good. Bolts must be tight.
x						day*	door interlock	If the machine operates with the door open: <ul style="list-style-type: none"> <li>• Immediately remove power.</li> <li>• Do not permit operation.</li> <li>• Speak to your dealer or Milnor.</li> </ul>
x						day*	emergency stop button (optional on some washer-extractors)	See <a href="#">Section 3.2.7</a> , page 33. Do a test of the control.
			x			600 hours	mechanical brake	See <a href="#">Section 3.3.3</a> , page 36. Do a test of the mechanical brake. If it does not operate correctly, repairs are necessary. Speak to your dealer or Milnor. This is not routine maintenance.

### 3.1.1.2 Filters, Screens, and Sensitive Components

BNUUUH01.R10 0000399352 A.5 A.26 A.19 11/16/21 10:29 AM Released

Remove contamination from these items to prevent damage and unsatisfactory performance.

**Table 2. Filters, Screens, and Sensitive Components**

Mark						Do this each	Component	More Data. See also <a href="#">Section 3.1.2</a> , page 19
1	2	3	4	5	6			
	x					40 to 60 hours	inverter fans, vents, filters	See <a href="#">Figure 9</a> , page 27. Keep good air flow.
			x			600 hours	motors	Keep good air flow.
					x	2400 hours	entire machine	Remove excessive dust and dirt.
x						day*	chemical inlet areas	Some chemical supplies that stay on machine surfaces will cause corrosion damage. See <a href="#">Section 3.2.3</a> , page 27 and <a href="#">Section 3.1.2</a> , page 19. See also, <a href="#">Section 2.3</a> , page 11 for background information.
x						day*	self-purging filter (and regulator) for compressed air	See <a href="#">Figure 16</a> , page 31. Make sure the bowl drains automatically.
		x				200 hours	filter element for the filter (and regulator)	Replace the filter if you cannot remove contamination.
				x		1200 hours	mufflers, quick exhaust valves	See <a href="#">Figure 17</a> , page 32

**Table 2 Filters, Screens, and Sensitive Components (cont'd.)**

Mark						Do this each	Component	More Data. See also <a href="#">Section 3.1.2</a> , page 19
1	2	3	4	5	6			
		x				200 hours	strainer(s) for air inlet	See <a href="#">Figure 15</a> , page 30
					x	2400 hours	strainer in water regulator for optional supply injector and pumped chemicals on some models.	See <a href="#">Figure 11</a> , page 28
		x				200 hours	strainer for steam inlet. (Steam is optional on some models.)	See <a href="#">Figure 14</a> , page 30
		x				200 hours	speed sensor photoeye. Optional on some models.	See <a href="#">Figure 18</a> , page 33
					x	2400 hours	proximity switches	See <a href="#">Figure 19</a> , page 33

### 3.1.1.3 Fluid Containers

BNUUUH01.R11 0000399351 A.5 A.26 A.16 11/16/21 9:04 AM Released

**Examine these items. Add fluid if necessary and keep components clean to prevent damage.**

**Table 3. Fluid Containers**

Mark						Do this each	Component	More Data. See also <a href="#">Section 3.1.3 : Lubricant Identification</a> , page 20
1	2	3	4	5	6			
		x				200 hours	Disc brake reservoir	See <a href="#">Figure 23</a> , page 37. Examine the oil level and quality. Add oil Dot3 ( <a href="#">Table 9</a> , page 20) if necessary. If the oil is contaminated, it is necessary to bleed the brake system. Speak to your dealer or Milnor. This is not routine maintenance.
						none	gear reducer — CO-BUDHFA, COBUD-E, COBUD-H	Sealed. No oil maintenance necessary.

### 3.1.1.4 Components that Become Worn

BNUUUH01.R12 0000399389 A.5 A.26 A.23 11/16/21 11:00 AM Released

**Examine these items. Tighten or replace the item if necessary, to prevent shutdowns and unsatisfactory performance. Speak to your dealer for replacement parts.**

**Table 4. Components that Become Worn**

Mark						Do this each	Component	More Data
1	2	3	4	5	6			
		x				200 hours	drive belts and pulleys	See <a href="#">Section 3.2.1</a> , page 25
		x				200 hours	tubes and hoses (non-hydraulic)	Examine hoses and hose connections for leaks.
		x				200 hours	tilt air bags	See <a href="#">Figure 17</a> , page 32
					x	1200 hours	door bumpers	Replace if damaged.
		x				200 hours	rubber springs	See <a href="#">Figure 24</a> , page 38
		x				200 hours	shock absorbers	See <a href="#">Section 3.3.4</a> , page 37
					x	1200 hours	tilt bumpers	See <a href="#">Figure 22</a> , page 36. Examine. Replace if damaged or worn.



### 3.1.1.5 Bearings and Bushings

BNUUUH01.R13 0000399388 A.5 A.26 11/16/21 11:04 AM Released

Unless the item is sealed, apply grease to prevent damage. See the next section for motors.

**Table 5. Bearings and Bushings**

Mark						Do this each	Component	More Data . See also <a href="#">Section 3.1.3 , page 20</a>
1	2	3	4	5	6			
Grease plate 01 10025Y for bearing housing. Use this data if your machine has this grease plate. See <a href="#">Figure 20, page 35</a> and <a href="#">Section 3.1.5 , page 21</a> . It is necessary to remove a side panel on some models, to access this grease plate.								
		x				200 hours	seal	Add 0.12 oz. (3.6 mL) of grease EPLF2 ( <a href="#">Table 9, page 20</a> )
		x				200 hours	rear bearing	Add 0.3 oz. (9 mL) of grease EPLF2
		x				200 hours	front bearing	Add 0.3 oz. (9 mL) of grease EPLF2
Other Grease Ports								
		x				200 hours	hydraulic door bushings	<a href="#">Figure 21, page 35</a> . Add 0.06 oz. (1.8 mL) of grease EPLF2 ( <a href="#">Lubricant Identification</a> )
		x				200 hours	door hinge	<a href="#">Figure 21, page 35</a> . Add 0.12 oz (3.6 mL) of grease EPLF2 ( <a href="#">Table 9, page 20</a> ).
		x				200 hours	door latch plunger	<a href="#">Figure 21, page 35</a> . Apply stick DE3 ( <a href="#">Table 9, page 20</a> ) to surface.
		x				200 hours	door open plunger	<a href="#">Figure 21, page 35</a> . Apply stick DE3 ( <a href="#">Table 9, page 20</a> ) to surface.
		x				200 hours	tilt pivots	<a href="#">Figure 22, page 36</a> Add 0.06 oz. (1.8 mL) of grease EPLF2 ( <a href="#">Table 9, page 20</a> ).
			x			600 hours	motor and pump bearings	See <a href="#">Section 3.1.6 : Procedures for Motors, page 22</a>

### 3.1.1.6 Motor Grease Schedule

BNUUUH01.R15 0000399408 A.5 A.26 10/21/21 10:14 AM Released

Use the data in [Table 10: Motor Grease Intervals and Quantities, page 24](#) to complete this table.

**Table 6. Motor Grease Schedule**

Motor Identification (example: main drive)	Interval		Quantity		Dates When Grease is Added								
	Years	Hours	fl oz	mL									

### 3.1.1.7 Mechanisms and Settings

BNUUUH01.R14 0000399409 A.5 A.26 A.11 11/16/21 11:14 AM Released

Make sure mechanisms are serviceable and settings are correct to prevent unsatisfactory performance.

**Table 7. Mechanisms and Settings**

Mark						Do this each	Component	More Data
1	2	3	4	5	6			
					x	2400 hours	controller circuitry	Examine wiring and connections in electrical boxes. Look for corrosion, loose connections. See <a href="#">Section 3.1.2</a> , page 19
		x				200 hours	water pressure regulator for optional supply injector	See <a href="#">Figure 11</a> , page 28. Value: 28 PSI (193 kPa).
		x				200 hours	water pressure regulator for chemical flush	See <a href="#">Figure 13</a> , page 29. Value: 28 PSI (193 kPa).
		x				200 hours	compressed air mechanisms	See <a href="#">Section 3.2.5</a> , page 30
		x				200 hours	bath level sensor that uses air pressure	Examine the air tube and connections. See <a href="#">Figure 12</a> , page 29
		x				200 hours	air pressure for bearing housing	See <a href="#">Figure 16</a> , page 31 Value: 10 PSI (69 kPa)

### 3.1.2 How To Remove Contamination

BNUU01.R03 0000335794 A.5 A.26 A.2 2/18/21 10:13 AM Released

**Table 8. Contamination Types, Cleaning Agents, and Procedures**

Material or Component	Usual Contamination	Example	Cleaning Agent	More Data
machine housing	dust, dirt	—	compressed air or shop vacuum	Air—no more than 30 psi (207 kPa). Do not push dust in mechanisms.
fins and vents on electrical components	dust	motors, inverters, braking resistors	shop vacuum, soft bristle brush, canned air for electrical components	Do not push dust in mechanisms.
electric box interior	dust	all electric boxes		
electrical connections	corrosion, varnish	spade connector, molex connector, plug-in relay	spray solvent for electrical components	Disconnect then connect it again. Use solvent if the bad connection continues.
electronic sensors	dust	photoeye lens, reflector, laser, proximity switch, temperature probe	none	Use a clean, soft, dry cloth.
	dirt		warm water with soap, then water flush	Use clean, soft cloths.
stainless steel	chemical spill	shell, supply injector	water	Use a hose to flush the chemical supply from the surface fully. Do not get water on electrical components or mechanisms.
300 series stainless steel	chemical corrosive attack	shell interior, cylinder	pickling and passivation	Speak to your dealer or Milnor. This is not routine maintenance.
painted metal, unpainted aluminum	dust, dirt, grease	frame members	warm water with soap, then water to flush	Use clean cloths. Do not get water in electrical components.
rubber	dirt, oil, grease	drive belts, hoses	warm water with soap, then water to flush	Use clean cloths. Flush fully. Oil or soap must not stay on drive belts. Make sure that drive belts are serviceable.

**Table 8 Contamination Types, Cleaning Agents, and Procedures (cont'd.)**

Material or Component	Usual Contamination	Example	Cleaning Agent	More Data
clear plastic, acrylic	discoloration (yellowing)	compressed air filter bowl, visual flow meter	warm water with soap, then water to flush, then acrylic cleaner. Do not use ammonia.	Use only the necessary cleaning agents. Wash and rinse with clean, soft cloths. Follow instructions on acrylic cleaner.
glass	discoloration (yellowing)	door glass, site glass	ammonia and water solution and water rinse then acetone	Use clean, soft cloths. Use only the necessary cleaning agents. If necessary, soak in cleaner.
soft air filter, lint filter,	dust, lint	on inverter electric box door, in air line filter bowl, in dryers	shop vacuum	Replace the used with a new filter when the vacuum cannot remove contamination.
rigid strainers, screens for water, steam	mineral particles	in water line, y-strainer	water	Use a rigid bristle brush. Flush with a flow of water.
rigid strainers, screens for oil	metal shavings	in hydraulic line	carburetor cleaner or equivalent solvent	Soak. Use a rigid bristle brush.
steel drive components	dirt, hardened lubricant	bearings, roller chains, sprockets, gears	carburetor cleaner or equivalent solvent	Soak. Use a cloth or soft bristle brush.

### 3.1.3 Lubricant Identification

BNUUUH01.R04 0000335793 A.5 A.26 A.13 11/8/21 11:43 AM Released

The table below identifies the lubricant for each lubricant code given in the maintenance summary. Get these or equivalent lubricants from your local lubricant supplier.

When you add grease, always use the procedures given in [Section 3.1.4 : Grease Gun Procedures, page 21](#). When you add grease to motors, also use the procedures given in [Section 3.1.6 : Procedures for Motors, page 22](#).



**CAUTION:** **Bad lubricant** — will decrease the life of components.

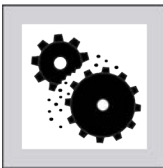

- ▶ Make sure that all equipment and fittings used to apply lubricants are clean.
- ▶ Use only the given lubricants or equivalent lubricants that have the same specifications.

**Table 9. Lubricant Identification**

Code	Type	Trademark Name	Application Example
EM	grease	Mobil Polyrex EM or as given on the motor nameplate	motor bearings
EPLF2	grease	Shell Alvania EP (LF) Type 2	drive shaft bearings and bushings, ball joints, chain drives
DOT3	oil	NAPA SuperHeavy Duty Brake Fluid DOT 3	disk brakes
23	oil	Shell Tellus 23	air line lubricator

**Table 9 Lubricant Identification (cont'd.)**

Code	Type	Trademark Name	Application Example
1030	oil	Shell Rotella T 10W30	Hydro-cushion™ cylinders
DE3	stick	AGS Door-Ease DE-3	door latch plunger

### 3.1.4 Grease Gun Procedures

BNUUUH01.R05 0000335825 A.5 A.26 A.3 9/21/21 1:10 PM Released



**CAUTION:** Hydraulic pressure — can push out seals and push grease into unwanted areas (example: motor windings).



- ▶ Use a hand grease gun. A power grease gun gives too much pressure.
- ▶ Know the quantity of grease your grease gun gives each cycle (each stroke).
- ▶ Operate the grease gun slowly (10 to 12 seconds for one cycle).
- ▶ Add only the specified quantity. Stop if new grease come out of a drain port or other opening.
- ▶ Remove spilled grease from belts and pulleys.

The tables give grease quantities in fluid ounces (fl oz) and milliliters (mL). You can also use grease gun cycles (strokes). A cycle is each time that you pull the trigger. One cycle is usually approximately 0.06 fl oz (1.8 mL). Your grease gun can give more or less than this. Measure the output of your grease gun as follows:

- Make sure that the grease gun operates correctly.
- Operate the grease gun to put grease into a small container with fluid ounce or milliliter increments. Pull the trigger fully and slowly.
- Add a sufficient quantity of grease to measure accurately. Count the number of cycles of the grease gun (the number of times that you pull the trigger).
- Calculate the quantity for each cycle of the grease gun, as in the following examples.

*Example: 2 fl oz / 64 cycles = 0.031 fl oz for each cycle*

*Example: 59 mL / 64 cycles = 0.92 mL for each cycle*

### 3.1.5 Procedures for Bearing Components Connected to a Grease Plate

BNUUUH01.R06 0000335824 A.5 A.26 A.3 10/4/21 4:04 PM Released

Your machine has a grease plate on the machine housing or the shell. You add grease to components of the bearing housing at this location. The correct procedure is to add grease when the cylinder turns at wash speed, but obey these precautions:

- For all other grease maintenance, add grease with power removed from the machine.
- If the grease plate on your machine is not serviceable (if you must add grease at a different location), add grease with power removed from the machine.

- If you must remove a guard to get access to the grease plate, prevent access to the machine by other personnel.

If you obey these precautions, use the **Manual** mode to operate the machine at wash speed. Then add grease at the grease plate.

### 3.1.6 Procedures for Motors

BNUUUH01.R07 0000335823 A.5 A.26 A.7 10/22/21 8:56 AM Released

If a motor on your machine does not have grease fittings, no grease maintenance is necessary. If a motor on your machine has grease fittings, it is necessary to add grease. But the interval is usually longer than for other maintenance. [Table 10: Motor Grease Intervals and Quantities, page 24](#) gives motor grease intervals and quantities for motors with specified frame sizes and speeds. You get this data from the motor nameplate. Use [Table 6: Motor Grease Schedule, page 18](#) to record the data for the motors on your machine.



**CAUTION:** Failure to remove grease drain plugs — can cause grease to enter the windings and burn out the motor.

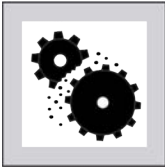

- ▶ If the motor has grease drain plugs, remove them before you add grease. If the motor has grease relief fittings, it is not necessary to remove them.

Figure 6. Motor Grease Maintenance Conditions

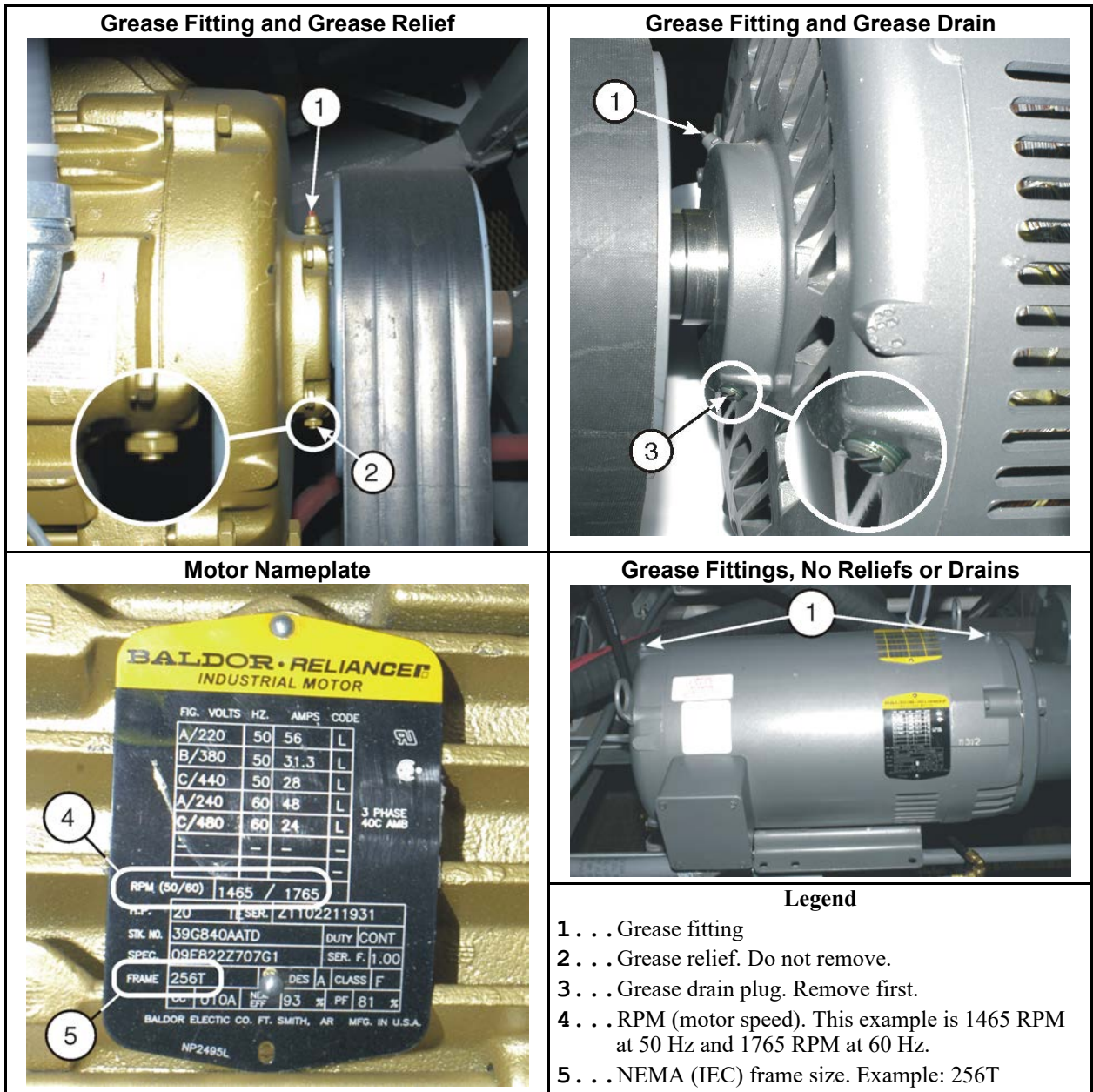

Apply grease as follows:

1. Operate the machine or use manual functions to operate the motor until it is warm.
2. Remove power from the machine.
3. If the motor has grease drain plugs, remove them. See the caution statement above..
4. Add grease EM ([Table 9: Lubricant Identification, page 20](#)) with the motor stopped. If the motor with the nameplate in the above figure operates at 60 Hz, the specified grease quantity for each grease fitting is 0.65 fl oz (18.4 mL).

- If the motor has a grease drain plugs, operate the machine or use manual functions to operate the motor for two hours. Replace the drain plug.

**Table 10. Motor Grease Intervals and Quantities**

On Motor Nameplate (see <a href="#">Figure 6: Motor Grease Maintenance Conditions, page 23</a> )		Interval		Quantity	
NEMA (IEC) Frame Size	RPM Less Than or Equal To	Years	Hours	Fluid Ounces	mL
Up to 210 (132)	900	5.5	11000	0.34	9.5
	1200	4.5	9000		
	1800	3	6000		
	3600	1.5	3000		
>210 to 280 (132 to 180)	900	4.5	9000	0.65	18.4
	1200	3.5	7000		
	1800	2.5	5000		
	3600	1	2000		
>280 to 360 (180 to 200)	900	3.5	7000	0.87	24.6
	1200	3	6000		
	1800	2	4000		
	3600	0.5	1000		
>360 to 5000 (200 to 300)	900	2.5	5000	2.23	63.2
	1200	2	4000		
	1800	1	2000		
	3600	0.5	1000		

### 3.1.7 How To Show the Maintenance On a Calendar

BNUUUH01.R01 0000333958 A.5 A.26 10/25/21 12:07 PM Released

You can put marks on a calendar that work with the tables in [Section 3.1.1 , page 15](#). The marks are the numbers 2, 3, 4, 5, and 6. It is not necessary to show the number 1 (items you do each day) on the calendar. The number 2 = items you do each 40 to 60 hours, 3 = each 200 hours, 4 = each 600 hours, 5 = each 1200 hours, and 6 = each 2400 hours. These are the "Mark" numbers at the top of the narrow columns on the left of each table in [Section 3.1.1 , page 15](#).

The table below shows where to put the marks on a calendar. For example, if your machine operates between 41 and 60 hours each week, the first three marks are 2, 2, and 3. Put these marks on the first, second, and third weeks after the machine starts operation. If you do routine maintenance on a given day of the week, put the mark on that day of each week. Continue to put marks on the subsequent weeks. **It can be necessary to do the 40 to 60 hour (2) maintenance more than one time each week.** If the machine operates between 61 and 100 hours, put a 2 on two days of the week. If the machine operates 101 or more hours, put a 2 on three days of the week.

On each date with a 3, do the items with an x in the 3 or the 2 column of each table in [Section 3.1.1 , page 15](#). On each date with a 4, do the items with an x in the 4, 3, or 2 column. Continue this pattern.

**Table 11. Where to Put Marks On a Calendar**

Hours / Week	Week Number																														
	1	2	3	4	5	6	7	8	9	10	11	12	13	14	15	16	17	18	19	20	21	22	23	24	25	26	27	28	29	30	
Up to 40	2	2	2	2	3	2	2	2	2	3	2	2	2	2	4	2	2	2	2	3	2	2	2	2	3	2	2	2	2	2	5
41 - 60	2	2	3	2	2	2	3	2	2	4	2	2	3	2	2	2	3	2	2	5	2	2	3	2	2	2	3	2	2	4	
61 - 80	2	2	3	2	3	2	4	2	2	3	2	2	3	2	5	2	3	2	2	3	2	4	2	2	3	2	2	3	2	6	
81 - 100	2	3	2	3	2	4	2	3	2	3	2	5	2	3	2	3	2	4	2	3	2	3	2	6	repeat						
101 - 120	2	3	2	3	4	2	3	2	3	5	2	3	2	3	4	2	3	2	3	6	repeat										
121 - 140	2	3	2	3	4	3	2	3	5	2	3	2	3	4	3	2	3	6	repeat												
Hours / Week	Week Number, continued																														
	31	32	33	34	35	36	37	38	39	40	41	42	43	44	45	46	47	48	49	50	51	52	53	54	55	56	57	58	59	60	
Up to 40	2	2	2	2	3	2	2	2	2	3	2	2	2	2	4	2	2	2	2	3	2	2	2	2	3	2	2	2	2	6	
41 - 60	2	2	3	2	2	2	3	2	2	6	repeat																				

BNWUUH01 / 2021444 BNWUUH01 0000335475 B.21 11/16/21 11:16 AM Released

## 3.2 Maintenance Components—Machines and Controls Group

BNWUUH01.C01 0000335474 A.5 B.21 A.4 6/28/21 3:03 PM Released

### 3.2.1 How to Examine V-belts and Pulleys

BNWUUH01.C02 0000335471 A.5 B.21 B.4 9/15/21 1:52 PM Released

**Figure 7. Belt and Pulley Conditions To Look For**

Types of Belt Damage	How to Find a Worn Pulley
<b>Legend</b>	
<p>1 . . . Broken cord—damage from a sharp object.</p> <p>2 . . . Cracks—belt is too large for the pulley.</p> <p>3 . . . Shiny side walls—oil or grease on belt.</p> <p>4 . . . The belt layers disconnect—Oil or grease.</p> <p>5 . . . Bands on side walls—dirt, particles.</p> <p>6 . . . Incorrect: The pulley is too worn.</p> <p>7 . . . Correct: The belt only touches the side walls. You can put a thin strip of paper into the space between the belt and the pulley.</p> <p>8 . . . Space</p>	

**With power removed:**

- Look for dirt, dust, oil, and grease. Remove contamination.



- Look for belt damage as shown in the figure above.
- Look for worn pulleys as shown in the figure above.

**With the machine in operation—Do not touch the machine.** Look and listen:

- A belt can have some vibration and not cause damage. It is necessary to correct this condition only if the vibration is large.
- A belt must have sufficient tension that there is no slippage on the pulley during operation. If slippage occurs, you can usually tell from the noise.

**About Component Replacement and Tension Adjustment**—Correct adjustment is very important to the service life of components and operation of the machine. Your Milnor® dealer can do this work. If you know how to do this work (for example, correctly align belts and pulleys), and you want to do it, speak to your dealer or Milnor® for part numbers. Replace worn components before you make tension adjustments.

- Machines that use rods with full threads and nuts to hold the position of the motor base—Turn the nuts on the rods as necessary to adjust tension. Tighten the nuts.
- Machines that use a spring to hold tension on the motor base—Use the belt tension sleeve supplied with the machine. Put the sleeve on the rod that the spring is attached to or remove the sleeve to increase or decrease tension (see the figure below). Replace the spring if necessary.

**Figure 8. How to Adjust Belt Tension On a Machine That Uses Spring Tension**

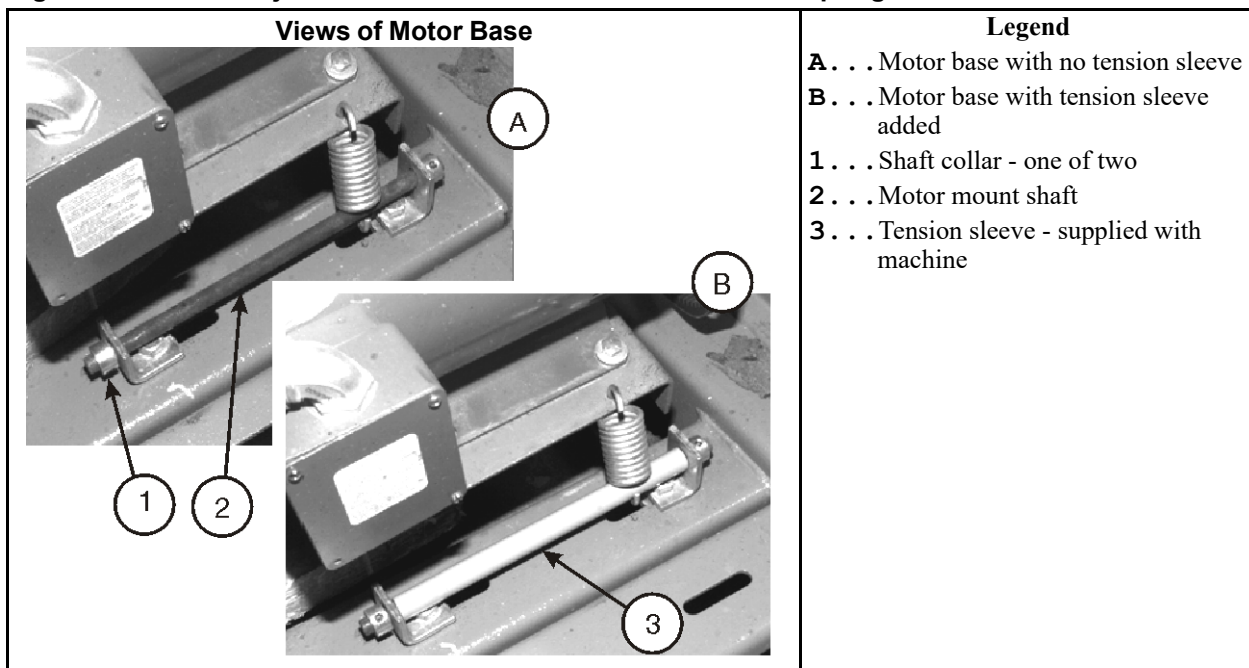

### 3.2.2 Inverters

BNWUUH01.C08 0000351755 A.5 B.21 A.4 10/12/21 9:38 AM Released



**CAUTION:** **Insufficient airflow** — will cause the inverter to burn out.

- ▶ Keep fans, filter, vents, and braking resistors clean.

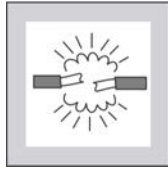

**Figure 9. Electric Box and Inverter.** These are examples. Your machine can look different.

30022X_ Washer-extractor	48040F_ Washer-extractor	76039 CBW® Tunnel Washer
<b>Legend</b>		
<p>1 . . . Air filter</p> <p>2 . . . Fan on electric box door. Tip: Put streamers in front of the fan to make sure the fan operates.</p> <p>3 . . . Inverter cooling vanes and vents. See caution statement below.</p> <p>4 . . . Braking resistor, if applicable</p>		

### 3.2.3 Chemical Devices

BNWUUH01.C09 0000351754 A.5 B.21 A.8 10/25/21 2:12 PM Released



**CAUTION:** **Chemical corrosion** — can damage the machine and the goods.

- ▶ Connect chemical tubes only to chemical manifold inlets.
- ▶ Stop leaks. Remove leaked supplies from surfaces.
- ▶ Speak to your dealer or Milnor® if you see corrosion damage.



**CAUTION:** **High water pressure** — can cause laundering chemicals to splash on personnel and machine surfaces.

- ▶ Make sure the pressure is set as told in the maintenance summary.



**Figure 10. Chemical Inlet Manifolds for Chemical Pump Systems. See caution statement below. These are examples. Your machine can look different.**

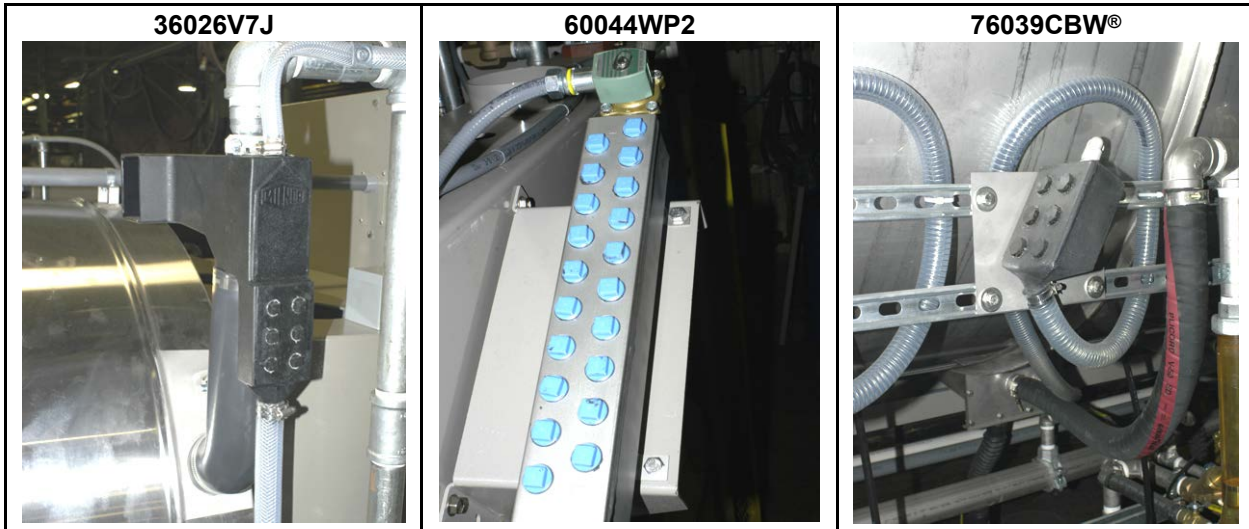

**Figure 11. Soap Chute and Optional 5-compartment Supply Injector. These are examples. Your machine can look different.**

<p style="text-align: center;"><b>Soap Chute</b></p>	<p style="text-align: center;"><b>Supply Injector</b></p>	<p style="text-align: center;"><b>Flush Water Adjustment Components</b></p>
<p><b>Legend</b></p> <p>1 . . . Do not let chemical supplies stay on surfaces.</p> <p>2 . . . Water pressure regulator. See caution statement below.</p> <p>3 . . . Adjustment screw</p> <p>4 . . . Water pressure gauge</p> <p>5 . . . Strainer inside</p>		

### 3.2.4 Water and Steam Devices

BNWUOH01.C10 0000351753 A.5 B.21 A.6 10/22/21 3:55 PM Released



**CAUTION:** **Restricted air flow** — can cause incorrect level readings.



- ▶ Keep the connecting tube or hose free of blockages and leaks.
- ▶ Make sure that the connections are tight.

**Figure 12. Air Tube for the Water Level Sensor. These are examples. Your machine can look different.**

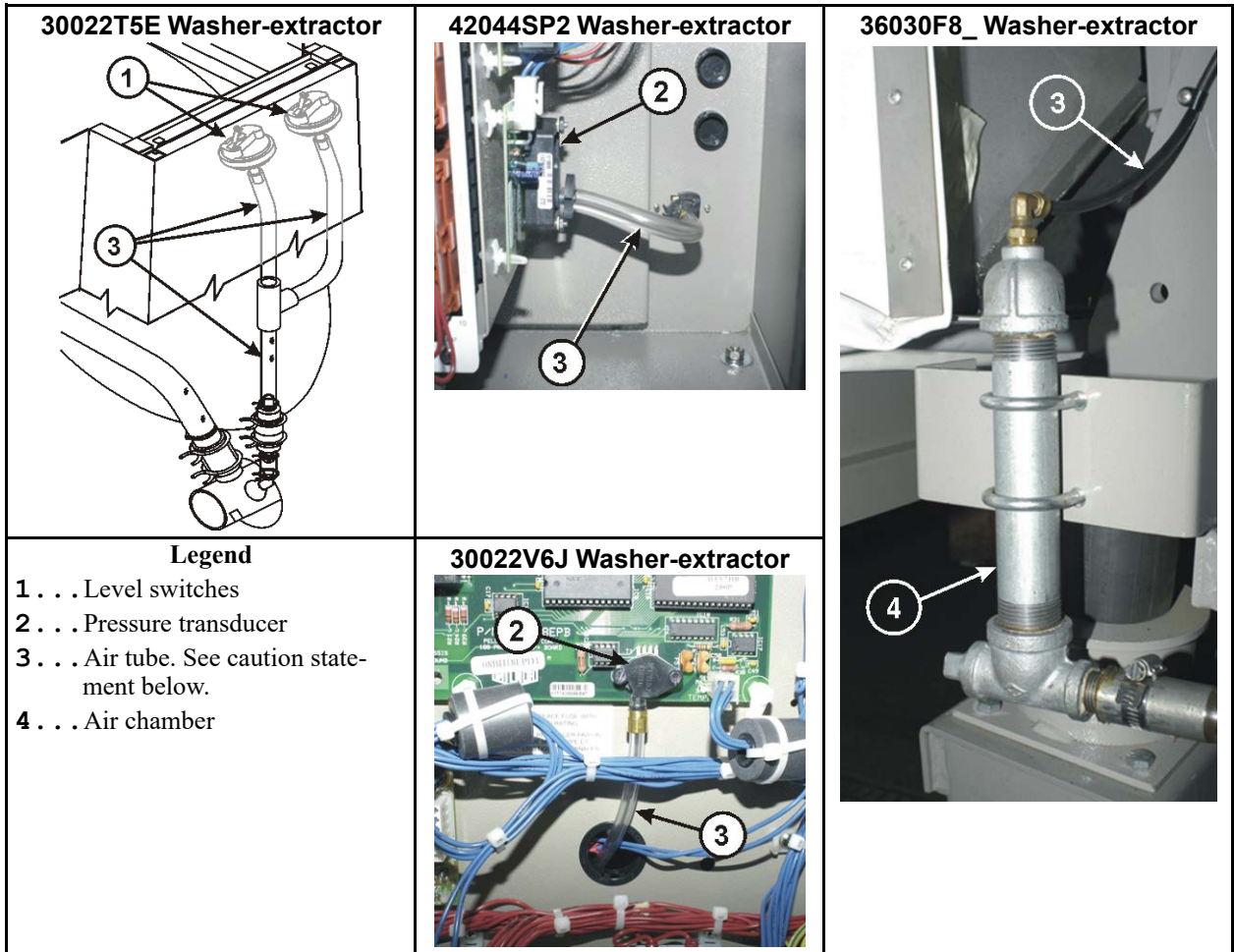

**Figure 13. Water Pressure Regulator for Chemical Flush. These are examples. Your machine can look different.**

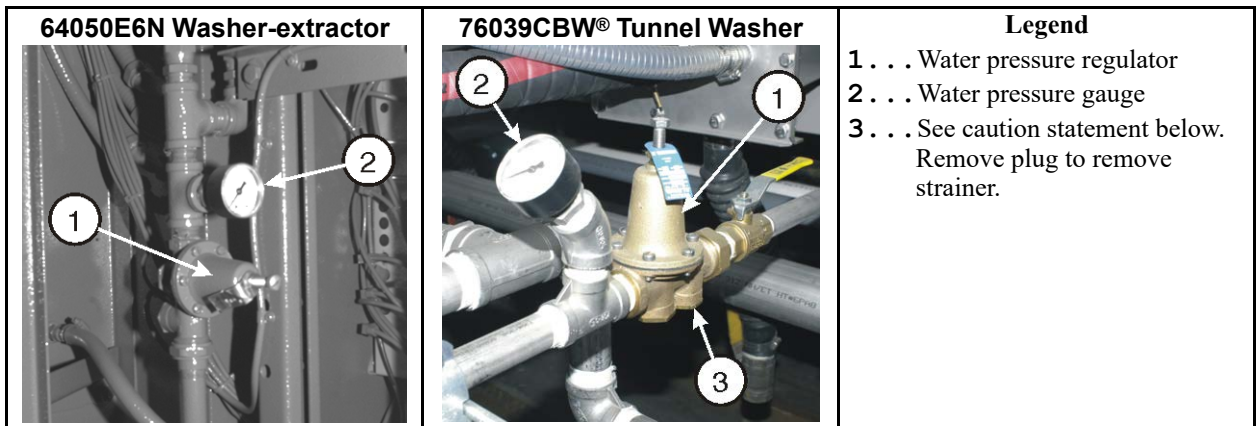



**CAUTION:** Release of pressurized steam — can severely burn you.



- ▶ Close the external shutoff valve and release remaining pressure before you do maintenance.

Figure 14. Steam Inlet Strainer. These are examples. Your machine can look different.

<p><b>42044SP2 Washer-extractor</b></p>	<p><b>76039CBW® Tunnel Washer</b></p>	<p><b>Legend</b></p> <p>1 . . . Steam strainer. Remove steam pressure before you remove the plug. See warning statement below.</p> <p>2 . . . Steam valve can burn</p>
---	---------------------------------------	--

### 3.2.5 How to Examine Compressed Air Mechanisms

BNWU01.C04 0000335530 A.5 B.21 A.8 10/14/21 2:00 PM Released



**CAUTION:** Compressed air pressure — can cause components to fly apart forcefully.



- ▶ Close the external shutoff valve and release remaining pressure before you do maintenance.

Figure 15. Compressed Air Inlet Strainers. These are examples. Your machine can look different.

<p><b>T-Strainer. Outside machine frame on some models.</b></p>	<p><b>T-Strainer. Inside machine frame on some models.</b></p>	<p><b>Y-strainer. Used on some models</b></p>
<p><b>Legend</b></p> <p>1 . . . See caution statement below. Remove plug to remove strainer.</p> <p>2 . . . Compressed air in.</p>		

**Figure 16. Self-purging Air Line Filter to Remove Moisture and Other Contamination. These are examples. Your machine can look different.**

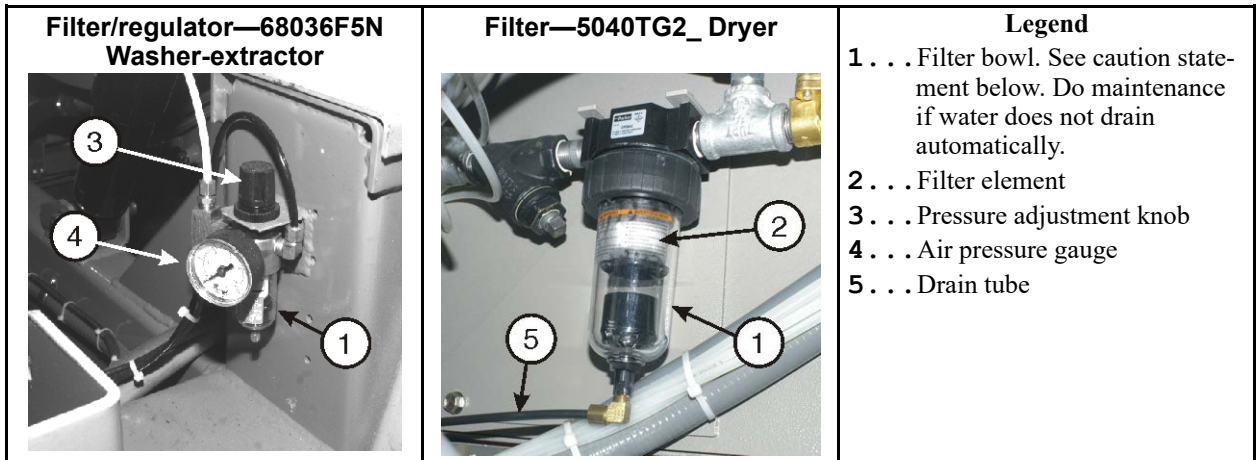

Your machine has one or more mechanisms that use compressed air for movement. [Figure 17, page 32](#) shows some examples. See the related figure in document BNVUUH01. To examine a compressed air mechanism, look at the mechanism and listen to it in operation. **Do not touch the mechanism or put your hand in the machine.** Usually you can see movement directly or on a position indicator. Frequently, you can hear a valve open and close. When a signal from the controller to operate the mechanism occurs, the air pressure must increase sufficiently before movement occurs. When the signal stops, the system must release the compressed air. You can usually hear the sound of the exhaust air for a short time.

When a compressed air mechanism operates correctly, its time of movement is usually less than two seconds. The movement is smooth. It does not shake, change speed, or stop in the middle of travel. A mechanism that does not operate correctly will cause unsatisfactory performance. If the mechanism does not operate correctly and you cannot repair the problem, speak to your dealer or Milnor®. Possible causes are as follows:

- a blockage or a leak in the air tube,
- a worn pilot air valve,
- worn components in the mechanism,
- air pressure supplied to the machine is not sufficient,
- a component used to remove contamination from the air line is clogged,
- a quick exhaust valve or muffler is clogged,
- on machines with an air line lubricator, a malfunction or incorrect adjustment prevents sufficient lubrication.

**Figure 17. Compressed Air Mechanisms These are examples. Your machine can look different.**

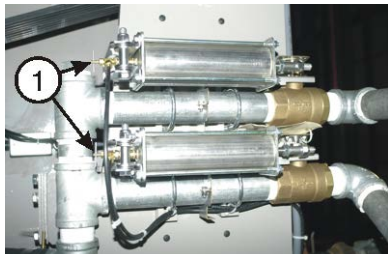
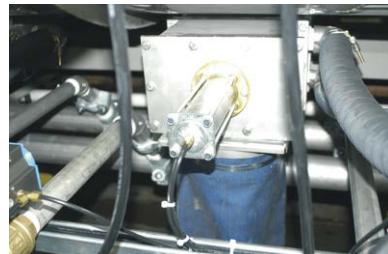
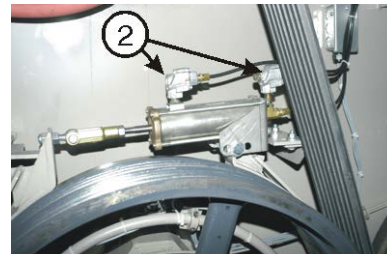
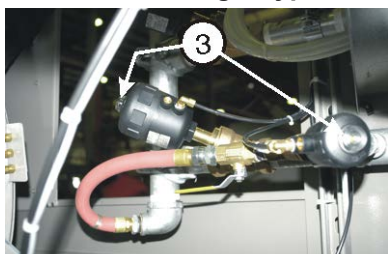
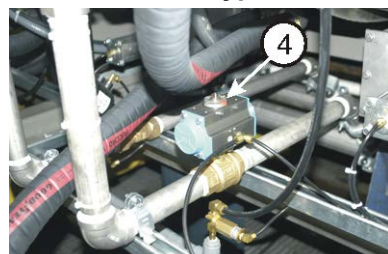
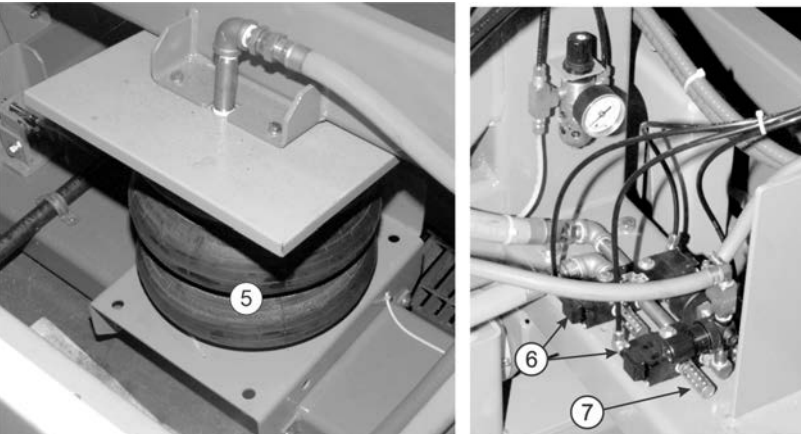
<p><b>Air Operated Water Valves - Milnor® Air Cylinder Type</b></p> 	<p><b>Air Operated Drain Valve - Milnor® Air Cylinder Type</b></p> 	<p><b>Air Operated Band Brake - Milnor® Air Cylinder Type</b></p> 
<p><b>Air Operated Water and Steam Valves - Angle Type</b></p> 	<p><b>Air Operated Water Valve - Ball Valve Type</b></p> 	<p><b>Legend</b></p> <ul style="list-style-type: none"> <li>1 . . . Factory-set needle valves to cause two air cylinders to move together. Do not adjust.</li> <li>2 . . . Quick exhaust valves</li> <li>3 . . . Position indicator. Yellow when valve is open.</li> <li>4 . . . Arrow position indicator</li> <li>5 . . . Tilt air bag</li> <li>6 . . . Air valve</li> <li>7 . . . muffler</li> </ul>
<p><b>Air Tilt Components</b></p> 		

### 3.2.6 Photoeyes and Proximity Switches

BNWUUH01.C11 0000351752 A.5 B.21 A.16 11/15/21 3:20 PM Released

Figure 18. Speed Sensor (photoeye) on Some Machines

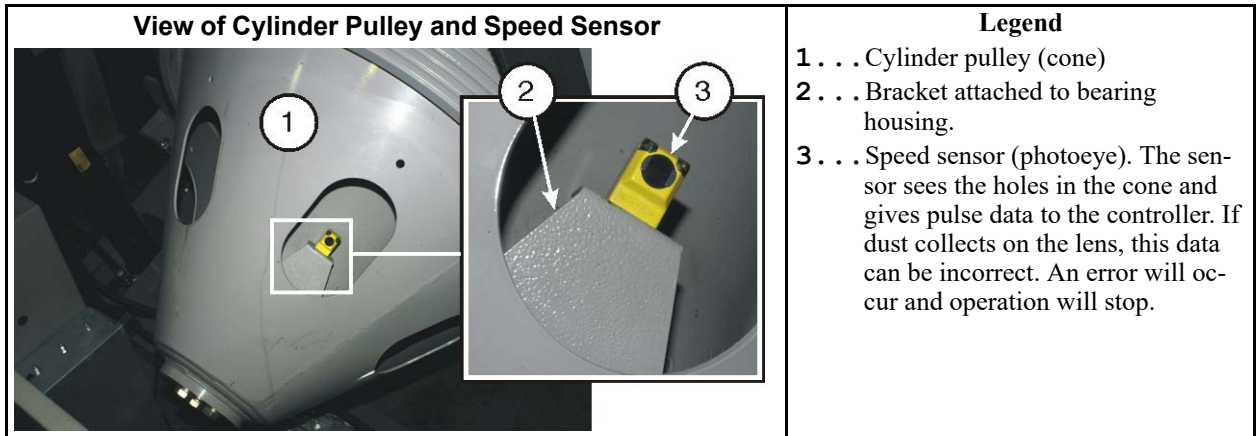
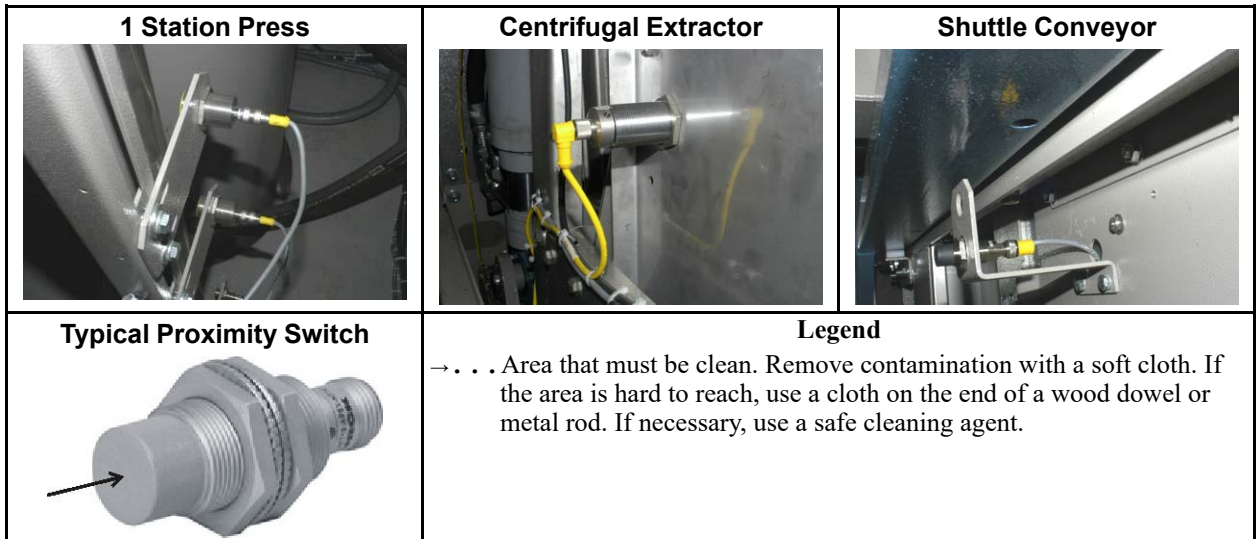

Figure 19. Proximity Switches These are examples. Your machine can look different.



### 3.2.7 How to Do a Test of Emergency Stop Mechanisms

BNWUUH01.C05 0000335566 A.5 B.21 A.4 2/23/21 11:58 AM Released

This test applies to machines that have one or more stop mechanisms in addition to the Stop button (⓪). Do this test at the intervals given in the maintenance summary.

Definitions:

**3-wire circuit** a series electrical circuit on a Milnor® machine that must close before the machine can operate. If a switch in the circuit opens, machine movement stops and the operator alarm (a buzzer and a display message) comes on. When you push the start button (①), this closes the 3-wire circuit, which stops the operator alarm and lets the machine operate.

**emergency stop mechanism** a manual control that opens the 3-wire circuit when a person or object operates the control. Examples - emergency stop button, kick plate, pull cord.



**emergency stop button** a red push button on a yellow field that locks when a person pushes it (the electrical contacts stay open). It is necessary to turn the button clockwise to unlock it. A machine can have zero or more emergency stop buttons.

**kick plate** a metal plate on a shuttle conveyor that operates a switch when an object applies sufficient force to the plate. The kick plate is usually the first component of the shuttle to hit an object in the shuttle path. All Milnor® shuttles that go left/right on a path have kick plates on the two sides of the machine.



**WARNING:** — You can be killed or severely injured if a shuttle strikes you even if you come in contact with the kick plate first.



- ▶ Never do a test of the kick plate when the shuttle operates.

**pull cord** a wire on a conveyor that operates a switch when a person pulls the wire. All Milnor® free-stand conveyors (a conveyor that is not a component of a larger machine) have pull cords on the two sides of the conveyor.

Do a test of all emergency stop mechanisms on the machine as follows:

1. Apply power to the machine (⏻).
2. Push the start button (①). **Do not cause the machine to operate.** For example, do not start a formula or operate the machine manually. It is not necessary to do the test when the machine operates.
3. Operate an emergency stop mechanism (examples - button, kick plate, pull cord). If the mechanism operates correctly, the operator alarm comes on. Did this occur?
  - Yes—Release the emergency stop mechanism if necessary. For example, if this is an emergency stop button, turn the button clockwise to unlock it. Push the start button (①). Do the test on a different emergency stop mechanism. Continue until you do the test on all emergency stop mechanisms on the machine.
  - No—An electrical component is defective. Shut down the machine. Do not let the machine operate until you correct the problem.

BNWBUH01 / 2021444

BNWBUH01 0000336079 B.15 10/27/21 11:55 AM Released

### 3.3 Maintenance Components—Large Extractors

BNWBUH01.C01 0000336078 A.5 B.15 B.2 6/28/21 11:22 AM Released

#### 3.3.1 Lubricant Maintenance for Grease-filled Drive Bearings

BNWBUH01.C08 0000351843 A.5 B.15 A.6 10/26/21 1:32 PM Released

Figure 20. Grease Ports for Grease-only Bearing Assembly

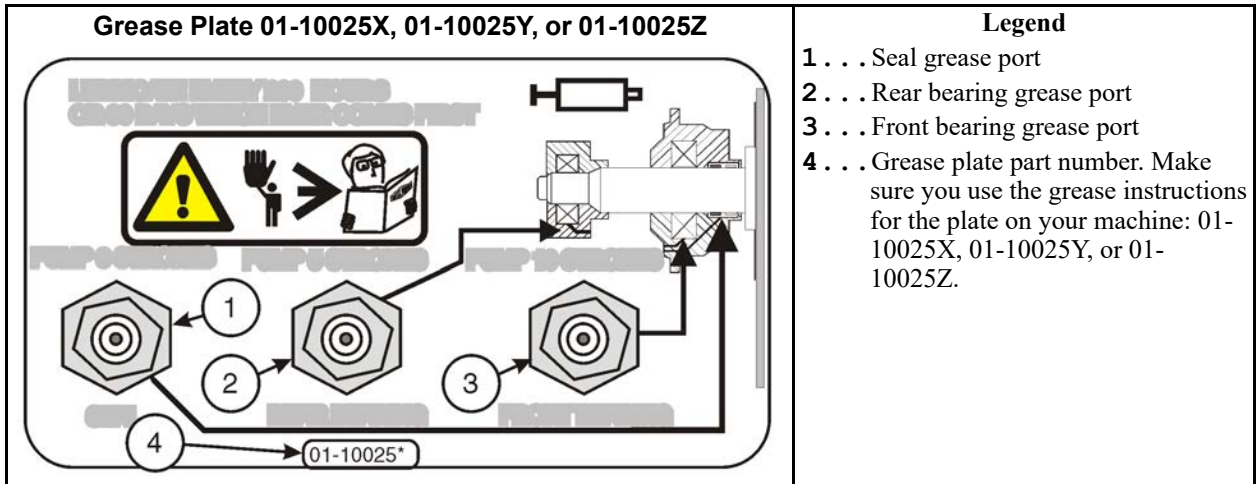

#### 3.3.2 Lubricant Maintenance for Non-drive Components

BNWBUH01.C09 0000351842 A.5 B.15 A.14 10/19/21 1:55 PM Released

Figure 21. Grease ports for Door—Open Pocket Models. These are examples. Your machine can look different.

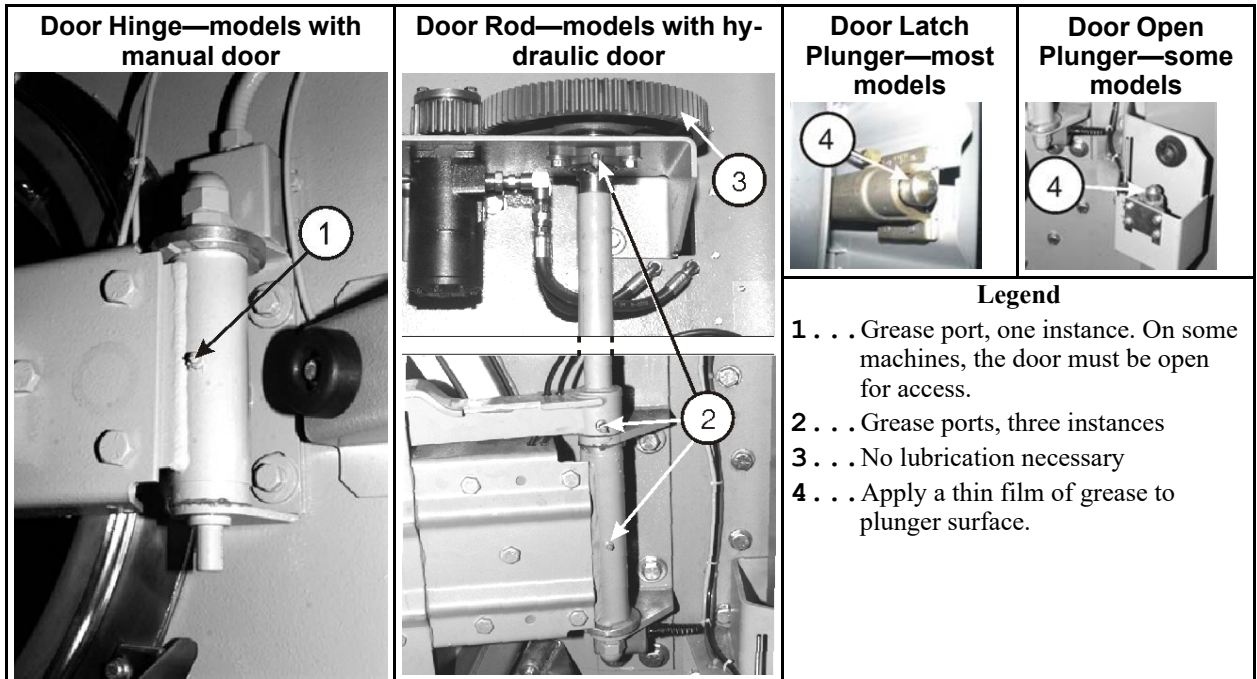

**Figure 22. Other Routine Maintenance Items on Each Side of 48040F7\_ Washer-extractor Models**

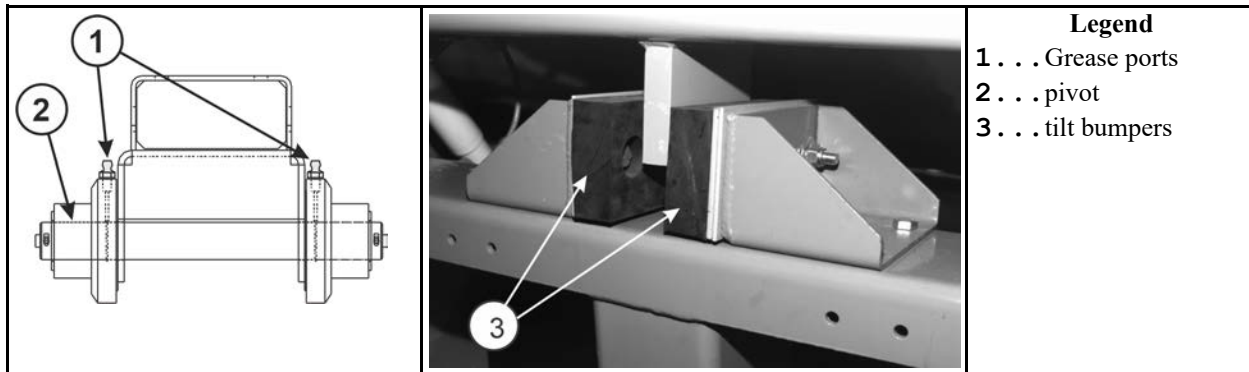

### 3.3.3 How to Do a Test of the Mechanical Brake

BNWBUH01.T01 0000336193 A.5 B.15 A.6 10/13/21 2:40 PM Released



**WARNING:** A moving cylinder and goods — can crush or sever body parts when a person reaches in the door to load or unload.



- ▶ Do not let the machine operate with a defective mechanical brake.

The disk or band brake holds the cylinder while the operator puts goods in, or removes goods from the machine. Although the mechanical brake does not usually stop the cylinder during operation (the second note below tells more), it can do so if an unusual condition occurs. Examples are when electrical power is removed and when a stop switch is pushed. To make sure the machine operates safely, do this test at the intervals given in the maintenance schedule:

1. If the machine contains goods, remove them.
2. Start a wash formula. Move forward in the sequence to a drain (see the first note below). You must do the test when the cylinder turns at drain speed. Wash speed is too slow. Extract speed will cause deterioration of the brake components that is not necessary.
3. Look at the cylinder through the door glass or site glass.
4. Push the *Emergency Stop* switch (⓪). Confirm that the cylinder stops in the time appropriate for the type of machine:
  - Divided cylinder and Staph Guard®—4 seconds.
  - Open cylinder—10 seconds



**NOTE:** On most machines, there is no manual output for drain speed. If your machine has a drain speed output in **Manual Mode**, use it instead of a formula.

If the cylinder does not stop in the given time, repairs are necessary. Speak to your dealer or Milnor®. This is not routine maintenance.



**CAUTION:** Misuse of the mechanical brake during automatic operation — will cause brake components to wear out quickly.

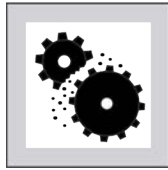

- ▶ During operation, always permit the cylinder to stop automatically.



**NOTE:** In automatic operation, the drive motor, inverter, and resistors stop the cylinder. If the cylinder does not stop in the correct length of time, an error message occurs. If this condition continues, repairs are necessary. Speak to your dealer or Milnor®. This is not routine maintenance.

**Figure 23.** Example of Disk Brake. Your machine can look different.

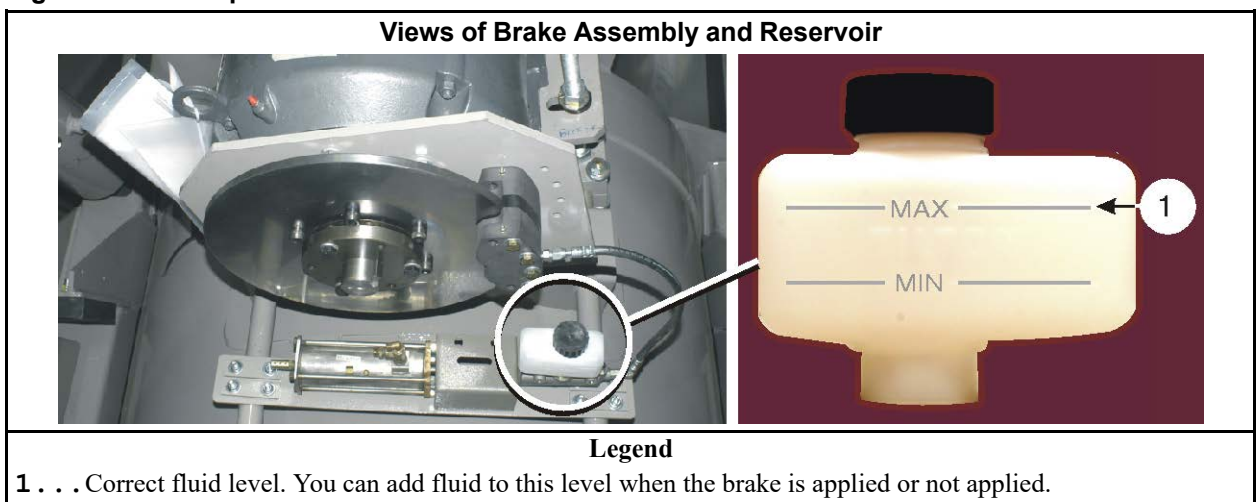

### 3.3.4 About the Shock Absorbers

BNWBUH01.C04 0000336165 A.5 B.15 A.7 10/13/21 11:58 AM Released

Milnor® washer-extractors with a rubber spring suspension also have shock absorbers. The shock absorbers have a different type of connection than those for automobiles. It is not necessary to replace the shock absorbers at specified intervals. It is only necessary to replace them if there is an indication that they are damaged or very worn.

Examine the shock absorbers at the intervals given in the maintenance summary. It is necessary to replace a shock absorber if you see oil come out from the mechanism (see the figure that follows). This shows that seals are worn. It is also necessary to replace the shock absorber if the rubber in a connector is very worn or missing.

Bad shock absorbers will let the shell move too much when the machine operates. If severe movement occurs and you are not sure of the cause, you can do a test of the shock absorbers as follows:

1. Remove the shock absorber from the machine.
2. With your body weight, compress the length of the shock absorber against a hard surface. A serviceable shock absorber compress slowly. It will also expand slowly to its initial length when you release it. If it compresses or expands quickly, the shock absorber is bad.

**Figure 24. Suspension Components on Each Side of Rubber Spring-resting Washer-extractor (see Section 3.3.4 : About the Shock Absorbers, page 37)**





Français

2







Numéro de manuel : MKWFBH01FR

Édition (ECN): 2021444

# Guide de maintenance

**Laveuse-essoreuse,  
suspendue par le bas,  
inclinaison pneumatique,  
\_F7B, \_F7D**



## Table des matières

1 Description et identification de la machine .....	4
1.1 À propos de ce manuel et de votre machine Milnor® .....	4
1.1.1 Description .....	4
1.1.2 Identification de la machine .....	5
• Plaque signalétique de machine .....	5
2 Sécurité .....	6
2.1 Laveuses-essoreuses à renversement .....	6
2.1.1 Messages d’alerte de sécurité—Risques électriques et mécaniques internes .....	6
2.1.2 Messages d’alerte de sécurité—Risques liés au cylindre et au traitement .....	7
2.1.3 Messages d’alerte de sécurité—Conditions dangereuses .....	9
2.1.3.1 Risques de dommages et de dysfonctionnements .....	9
2.1.3.1.1 Risques liés à des dispositifs de sécurité non opérationnels.....	9
2.1.3.1.2 Risques liés à des dispositifs mécaniques endommagés .....	10
2.1.3.2 Risques liés à une utilisation négligente.....	10
2.1.3.2.1 Risques liés à une utilisation négligente—Informations essen- tielles pour les opérateurs (voir également les risques pour les opé- rateurs dans le manuel).....	10
2.1.3.2.2 Risques liés à un entretien négligent—Informations essentielles pour le personnel chargé de l’entretien (voir également les risques liés à l’entretien dans les manuels).....	11
2.2 Utilisez les supports de sécurité rouges pour la maintenance — 48040F7B, 48040F7D .....	12
2.2.1 Supports de sécurité fournis et usage .....	12
2.2.2 Déploiement des chandelles de sécurité .....	13
2.3 Prévention des dommages dus à des produits chimiques et à des systèmes de pro- duits chimiques .....	13
2.3.1 Comment les produits chimiques peuvent provoquer des dommages.....	14
• Formules de lavage et produits chimiques dangereux .....	14
• Configuration ou raccordement incorrect des équipements.....	14
2.3.2 Équipements et procédures permettant d’éviter des dommages .....	17
• Utilisez le collecteur de produits chimiques fourni. ....	17
• Fermez le conduit. ....	18
• Ne laissez pas se produire une aspiration.....	18
• Rincez à l’eau le tube de produits chimiques.....	18
• Placez le tube de produits chimiques entièrement en dessous de l’entrée.....	18
• Empêchez les fuites.....	18
3 Maintenance de routine .....	19
3.1 Maintenance de routine .....	19
3.1.1 Résumé de l’entretien.....	19
3.1.1.1 Protections et composants concernés .....	20
3.1.1.2 Filtres, écrans et composants sensibles .....	20
3.1.1.3 Conteneurs de liquide.....	21
3.1.1.4 Pièces d’usure .....	21
3.1.1.5 Paliers et bagues .....	22

3.1.1.6	Planning de graissage du moteur.....	23
3.1.1.7	Mécanismes et réglages.....	23
3.1.2	Comment décontaminer.....	24
3.1.3	Identification du lubrifiant.....	25
3.1.4	Procédures de graissage au pistolet.....	26
3.1.5	Procédures pour composants de palier reliés à une plaque de graissage.....	26
3.1.6	Procédures pour les moteurs.....	27
3.1.7	Affichage de l'entretien dans un calendrier.....	29
3.2	Composants de maintenance—Groupes machines et commandes.....	31
3.2.1	Examen des courroies en V et des poulies.....	31
3.2.2	Inverseurs.....	32
3.2.3	Dispositifs chimiques.....	33
3.2.4	Dispositifs à eau et à vapeur.....	34
3.2.5	Examen des mécanismes à air comprimé.....	36
3.2.6	Cellules photoélectriques et détecteurs de proximité.....	39
3.2.7	Comment effectuer un test des mécanismes d'arrêt d'urgence.....	39
3.3	Composants de maintenance—Grandes essoreuses.....	41
3.3.1	Maintenance du lubrifiant pour les paliers d'entraînement remplis de graisse.....	41
3.3.2	Maintenance du lubrifiant pour les composants qui ne font pas partie de la transmission.....	42
3.3.3	Comment effectuer un test du frein mécanique.....	42
3.3.4	À propos des amortisseurs.....	44

## Figures

Figure 1	Plaque signalétique de machine.....	5
Figure 2	Configurations incorrectes qui laissent les produits chimiques passer dans la machine par un siphon.....	15
Figure 3	Configurations incorrectes qui laissent les produits chimiques passer dans la machine par gravité.....	16
Figure 4	Exemples de collecteurs pour tubes de produits chimiques. Votre équipement peut être différent.....	17
Figure 5	Une configuration qui empêche l'écoulement dans la machine lorsque la pompe est arrêtée (si le réservoir et le tube de produits chimiques ne présentent aucune pression).....	18
Figure 6	Conditions de lubrification du moteur.....	28
Figure 7	Conditions des courroies et des poulies à contrôler.....	31
Figure 8	Comment régler la tension de la courroie sur une machine qui utilise la tension du ressort.....	32
Figure 9	Boîtier électrique et inverseur Il s'agit d'exemples. Votre machine peut être différente.....	33
Figure 10	Collecteurs d'entrée de produits chimiques pour les systèmes de pompage de produits chimiques. Voir la mise en garde ci-dessous. Il s'agit d'exemples. Votre machine peut être différente.....	34
Figure 11	Trémie à savon et injecteur d'alimentation à 5 compartiments en option. Il s'agit d'exemples. Votre machine peut être différente.....	34

Figure 12	Tube d'air pour le capteur de niveau d'eau. Il s'agit d'exemples. Votre machine peut être différente. ....	35
Figure 13	Régulateur de pression d'eau de rinçage des produits chimiques. Il s'agit d'exemples. Votre machine peut être différente. ....	35
Figure 14	Tamis d'entrée de vapeur. Il s'agit d'exemples. Votre machine peut être différente. ....	36
Figure 15	Tamis d'entrée d'air comprimé. Il s'agit d'exemples. Votre machine peut être différente. ....	36
Figure 16	Filtre de conduite d'air à purge automatique servant à supprimer l'humidité et d'autres contaminations. Il s'agit d'exemples. Votre machine peut être différente. ....	37
Figure 17	Mécanismes à air comprimé. Ce sont des exemples. Votre machine peut être différente. ....	38
Figure 18	Capteur de vitesse (cellule photoélectrique) sur certaines machines. ....	39
Figure 19	Détecteurs de proximité Ce sont des exemples. Votre machine peut être différente. ....	39
Figure 20	Orifices de graissage pour assemblage de palier à graisse uniquement .....	41
Figure 21	Orifices de graissage de porte—Modèles à poche ouverte. Il s'agit d'exemples. Votre machine peut être différente. ....	42
Figure 22	Autres éléments de la maintenance de routine de chaque côté des modèles de laveuse-essoreuse 48040F7_ .....	42
Figure 23	Exemple de frein à disque. Votre machine peut être différente. ....	44
Figure 24	Composants de la suspension de chaque côté de la laveuse-essoreuse reposant sur ressorts en caoutchouc (voir 3.3.4 À propos des amortisseurspage 44) .....	45

## Tableaux

Tableau 1	Protections et composants concernés .....	20
Tableau 2	Filtres, écrans et composants sensibles .....	20
Tableau 3	Conteneurs de liquide .....	21
Tableau 4	Pièces d'usure .....	22
Tableau 5	Paliers et bagues .....	22
Tableau 6	Planning de graissage du moteur .....	23
Tableau 7	Mécanismes et réglages .....	23
Tableau 8	Types de contamination, agents de nettoyage et procédures .....	24
Tableau 9	Identification du lubrifiant .....	25
Tableau 10	Quantités et intervalles de graissage du moteur .....	29
Tableau 11	Placement des repères dans un calendrier .....	30

# 1 Description et identification de la machine

BNUUUF02 / 2024423

BNUUUF02 0000582472 B.2 1/13/25, 8:12 AM Released

## 1.1 À propos de ce manuel et de votre machine Milnor®

BNUUUF02.C01 0000582446 A.2 B.2 8/30/23, 2:31 PM Released

Ce manuel s'applique à deux modèles ou plus qui partagent les caractéristiques mécaniques indiquées ci-dessous. Si vous avez reçu ce manuel avec votre machine, votre machine est l'un des modèles concernés. Toutefois, avant d'utiliser ce manuel, vérifiez que votre machine a bien ces caractéristiques.

### 1.1.1 Description

BNUUUF02.C02 0000582417 A.2 B.2 E.2 1/13/25, 8:12 AM Released

Les laveuses-essoreuses lavent le linge avec de l'eau et des produits chimiques non volatiles qui extraient l'excès d'eau grâce à la force centrifuge. Cette laveuse-essoreuse est le type mécanique décrit ci-dessous.

**\_F7B, \_F7D** Une machine représentée par l'un de ces numéros de modèles partiels est une laveuse-essoreuse pneumatique à inclinaison pour le chargement et le déchargement suspendue par le bas (ressorts en caoutchouc) avec des paliers à graisse et un frein (à disque) mécanique. Sa capacité est de 275 livres (125 kg).

## 1.1.2 Identification de la machine

BNUUUF02.R01 0000582491 A.2 B.2 8/30/23, 2:31 PM Released

**Plaque signalétique de machine** — Repérez le numéro de modèle et d’autres données pour votre machine sur la plaque signalétique fixée sur la machine et décrite ci-dessous.

**Figure 1. Plaque signalétique de machine**

Vue de la plaque signalétique (texte anglais illustré)	Légende
<p>The diagram shows a nameplate for Pellerin Milnor Corporation. At the top left is the Milnor logo (1). To its right is the company name and location (2). Below this is a section for identification: MODEL, SERIAL, and DATE CODE. The SERIAL field is split into MIN. and MAX. Below this is RPM (3) and VOLUME (4). To the right of VOLUME is YEAR MFG. Below these are fields for STEAM and WATER (5). At the bottom is a section for electrical requirements: RUN AMPS, FOR, MAX FUSE AMPS, and MIN. WIRE AWG (6). The number 01-10092E is printed vertically on the right side of the nameplate.</p>	<p><b>Légende</b></p> <ol style="list-style-type: none"> <li>1. Numéro de modèle.</li> <li>2. Données qui identifient votre machine de manière unique. Indiquez ces données lorsque vous parlez de votre machine avec votre revendeur ou Milnor®.</li> <li>3. Vitesse de rotation maximale du cylindre en tours par minute</li> <li>4. Volume du cylindre dans les unités de mesure indiquées</li> <li>5. Exigences liées aux conduites</li> <li>6. Exigences électriques</li> </ol>

# 2 Sécurité

BNWHTS08 / 2021243

BNWHTS08

0000582483

8/30/23, 2:31 PM

Released

## 2.1 Laveuses-essoreuses à renversement

BNWHTS08.C01 0000582488 A.2 8/30/23, 2:31 PM Released

### 2.1.1 Messages d'alerte de sécurité—Risques électriques et mécaniques internes

BNWHTS01.C03 0000582422 A.2 B.2 8/30/23, 2:31 PM Released

Vous trouverez ci-dessous des instructions concernant les risques à l'intérieur de la machine et dans les boîtiers électriques.



**AVERTISSEMENT : Risques d'électrocution et de brûlures électriques** — Tout contact avec une tension électrique peut vous blesser gravement ou vous tuer. Une tension électrique est présente dans le boîtier, à moins que le principal dispositif de déconnexion de la machine soit en position hors tension.

- ▶ Ne déverrouillez pas et n'ouvrez pas les portes des boîtiers électriques.
- ▶ Ne retirez pas les protections, capots ou panneaux.
- ▶ N'entrez pas dans l'enceinte ni dans le cadre de la machine.
- ▶ Tenez les autres personnes et vous-même à l'écart de la machine.
- ▶ Vous devez connaître l'emplacement du principal dispositif de déconnexion de la machine, et l'utiliser en cas d'urgence afin de mettre la machine hors tension.



**AVERTISSEMENT : Risques d'enchevêtrement et d'écrasement** — Tout contact avec des composants mobiles normalement isolés par des protections, capots et panneaux peut entraîner et écraser vos membres. Ces composants entrent en mouvement automatiquement.

- ▶ Ne retirez pas les protections, capots ou panneaux.
- ▶ N'entrez pas dans l'enceinte ni dans le cadre de la machine.
- ▶ Tenez les autres personnes et vous-même à l'écart de la machine.
- ▶ Familiarisez-vous avec l'emplacement de tous les boutons d'arrêt d'urgence, cordons de traction et/ou plaques de poussée et utilisez-les en cas d'urgence pour arrêter le mouvement de la machine.



**AVERTISSEMENT : Risques d'écrasement** — Machines à renversement uniquement—L'enceinte de la machine écrasera votre corps ou vos membres si elle descend ou tombe alors que vous vous trouvez au-dessous. L'enceinte peut descendre pendant la mise sous ou hors tension. L'actionnement manuel des vannes de renversement contourne les verrouillages de sécurité. Un actionnement incorrect des vannes de renversement manuelles peut faire descendre l'enceinte.

- ▶ Ne retirez pas les protections, capots ou panneaux.
- ▶ N'entrez pas dans l'enceinte ni dans le cadre de la machine.

## 2.1.2 Messages d'alerte de sécurité—Risques liés au cylindre et au traitement

BNWHTS03.C03 0000582501 A.2 8/30/23, 2:31 PM Released

Vous trouverez ci-dessous des instructions concernant les risques liés au cylindre et au processus de lavage.



**DANGER : Risques d'enchevêtrement et de rupture** — Tout contact avec le linge traité peut entraîner l'enroulement du linge autour de votre corps ou de vos membres et l'arrachage de vos membres. Le linge est normalement isolé par la porte verrouillée du cylindre.

- ▶ N'essayez pas d'ouvrir la porte pour accéder à l'intérieur du cylindre avant son arrêt complet.
- ▶ Ne touchez pas le linge à l'intérieur ou qui pend partiellement hors du cylindre en rotation.
- ▶ Ne faites pas fonctionner la machine alors que le verrouillage de la porte ne fonctionne pas correctement.
- ▶ Machines à poches ouvertes uniquement—Ne faites pas fonctionner le cylindre par à-coups tout en tirant sur le linge.
- ▶ Machines à poches ouvertes uniquement—Tenez les autres personnes et vous-même à l'écart du cylindre et du linge pendant le fonctionnement par à-coups.
- ▶ Ne faites pas fonctionner la machine alors que les commandes à deux mains ne fonctionnent pas correctement.
- ▶ Familiarisez-vous avec l'emplacement de tous les boutons d'arrêt d'urgence, cordons de traction et/ou plaques de poussée et utilisez-les en cas d'urgence pour arrêter le mouvement de la machine.
- ▶ Vous devez connaître l'emplacement du principal dispositif de déconnexion de la machine, et l'utiliser en cas d'urgence afin de mettre la machine hors tension.





**AVERTISSEMENT : Risques d'écrasement** — Tout contact avec le cylindre en rotation peut écraser vos membres. Le cylindre expulsera tout objet utilisé pour essayer de l'arrêter, et l'objet risquera alors de vous heurter ou de vous couper. Le cylindre en rotation est normalement isolé par la porte verrouillée du cylindre.

- ▶ N'essayez pas d'ouvrir la porte pour accéder à l'intérieur du cylindre avant son arrêt complet.
- ▶ Ne placez aucun objet dans le cylindre en rotation.
- ▶ Ne faites pas fonctionner la machine alors que le verrouillage de la porte ne fonctionne pas correctement.
- ▶ Machines à poches ouvertes uniquement—Tenez les autres personnes et vous-même à l'écart du cylindre et du linge pendant le fonctionnement par à-coups.
- ▶ Ne faites pas fonctionner la machine alors que les commandes à deux mains ne fonctionnent pas correctement.



**AVERTISSEMENT : Risques liés aux espaces confinés** — Le confinement à l'intérieur du cylindre peut provoquer des blessures graves ou la mort. Les risques incluent, sans limitation, la panique, des brûlures, l'empoisonnement, la suffocation, un coup de chaleur, une contamination biologique, une électrocution et un écrasement.

- ▶ N'essayez pas de réaliser l'entretien, des réparations ni des modifications sans autorisation.



**AVERTISSEMENT : Risques d'explosion et d'incendie** — Des substances inflammables peuvent exploser ou prendre feu dans le cylindre, les tuyaux de vidange ou les égouts. La machine est conçue pour laver à l'eau, pas avec des solvants. Le traitement peut entraîner le dégagement de vapeurs inflammables par du linge contenant des solvants.

- ▶ N'utilisez pas de solvants inflammables pour le traitement.
- ▶ Ne traitez pas de linge contenant des substances inflammables. Consultez votre service local de lutte contre le feu, la sécurité publique et tous les assureurs.

## 2.1.3 Messages d'alerte de sécurité—Conditions dangereuses

BNWHTS04.C01 0000579061 A.2 A.3 7/11/23, 3:27 PM Released

### 2.1.3.1 Risques de dommages et de dysfonctionnements

BNWHTS04.C02 0000579093 A.2 A.3 7/11/23, 3:27 PM Released

#### 2.1.3.1.1 Risques liés à des dispositifs de sécurité non opérationnels

BNWHTS04.C03 0000579097 A.2 A.3 7/11/23, 3:27 PM Released



**DANGER : Risques d'enchevêtrement et de rupture** — Verrouillage de la porte du cylindre—L'utilisation de la machine avec un verrouillage de la porte défaillant peut permettre l'ouverture de la porte alors que le cylindre tourne et/ou le lancement du cycle avec la porte ouverte, et exposer le cylindre en rotation.

- ▶ Ne faites pas fonctionner la machine en cas de signe de dommages ou de dysfonctionnement.



**AVERTISSEMENT : Risques multiples** — L'utilisation de la machine avec un dispositif de sécurité non opérationnel peut tuer ou blesser le personnel, endommager ou détruire la machine, endommager des biens et/ou annuler la garantie.

- ▶ Ne modifiez et ne désactivez aucun dispositif de sécurité ou ne faites pas fonctionner la machine alors qu'un dispositif de sécurité ne fonctionne pas correctement. Adressez-vous au service autorisé.

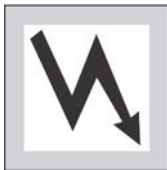

**AVERTISSEMENT : Risques d'électrocution et de brûlures électriques** — Portes des boîtiers électriques—Le fonctionnement de la machine avec une porte de boîtier électrique ouverte peut exposer des conducteurs à haute tension à l'intérieur du boîtier.

- ▶ Ne déverrouillez pas et n'ouvrez pas les portes des boîtiers électriques.



**AVERTISSEMENT : Risques d'enchevêtrement et d'écrasement** — Protections, capots et panneaux—Le fonctionnement de la machine alors que des protections, capots ou panneaux ont été retirés expose les composants mobiles.

- ▶ Ne retirez pas les protections, capots ou panneaux.



**AVERTISSEMENT : Risques d'écrasement** — Détecteurs de limite basse (machines avec cylindres à renversement avant et arrière)—Une défaillance des deux détecteurs de limite avant ou arrière permet aux roues de renversement de sortir de leurs logements par le haut sur une machine basculée. L'enceinte risque de tomber et d'avancer ou de reculer.

- ▶ Ne faites pas fonctionner la machine en cas de signe de dommages ou de dysfonctionnement.

### 2.1.3.1.2 Risques liés à des dispositifs mécaniques endommagés

BNWHTS04.C04 0000579160 A.2 A.3 7/11/23, 3:27 PM Released



**AVERTISSEMENT : Risques multiples** — L'utilisation d'une machine endommagée peut tuer ou blesser le personnel, endommager encore plus ou détruire la machine, endommager des biens et/ou annuler la garantie.

- ▶ Ne faites pas fonctionner une machine endommagée ou qui présente un dysfonctionnement. Adressez-vous au service autorisé.



**AVERTISSEMENT : Risques d'explosion** — Cylindre—Un cylindre endommagé peut s'arracher pendant l'extraction, perforer l'enveloppe et expulser des fragments métalliques à grande vitesse.

- ▶ Ne faites pas fonctionner la machine en cas de signe de dommages ou de dysfonctionnement.



**AVERTISSEMENT : Risques d'explosion** — Embrayage et commutateur de vitesse (machines à plusieurs moteurs)—Un embrayage ou un commutateur de vitesse endommagé peut permettre l'engagement du moteur à basse vitesse pendant l'essorage. Cela fera tourner trop vite le moteur et les poulies et risque de les arracher et d'expulser des fragments métalliques à grande vitesse.

- ▶ Arrêtez immédiatement la machine dans tous les cas suivants : • bruit anormal pendant l'essorage • bruit de patinage en fin d'essorage • le système d'embrayage reste engagé ou redevient engagé pendant l'essorage

### 2.1.3.2 Risques liés à une utilisation négligente

BNWHTS04.C05 0000579057 A.2 A.3 7/11/23, 3:27 PM Released

#### 2.1.3.2.1 Risques liés à une utilisation négligente—Informations essentielles pour les opérateurs (voir également les risques pour les opérateurs dans le manuel)

BNWHTS04.C06 0000579080 A.2 A.3 7/11/23, 3:27 PM Released



**AVERTISSEMENT : Risques multiples** — Des actions négligentes des opérateurs peuvent tuer ou blesser le personnel, endommager ou détruire la machine, endommager des biens et/ou annuler la garantie.

- ▶ Ne modifiez et ne désactivez aucun dispositif de sécurité ou ne faites pas fonctionner la machine alors qu'un dispositif de sécurité ne fonctionne pas correctement. Adressez-vous au service autorisé.
- ▶ Ne faites pas fonctionner une machine endommagée ou qui présente un dysfonctionnement. Adressez-vous au service autorisé.
- ▶ N'essayez pas de réaliser l'entretien, des réparations ni des modifications sans autorisation.
- ▶ N'utilisez la machine d'aucune manière contraire aux instructions d'usine.
- ▶ N'utilisez la machine que pour son usage habituel et prévu.

- ▶ Comprendre les conséquences d'une utilisation manuelle.

### 2.1.3.2.2 Risques liés à un entretien négligent—Informations essentielles pour le personnel chargé de l'entretien (voir également les risques liés à l'entretien dans les manuels)

BNWHTS04.C07 0000579067 A.2 A.3 7/11/23, 3:27 PM Released



**AVERTISSEMENT : Risques d'électrocution et de brûlures électriques** — Tout contact avec une tension électrique peut vous blesser gravement ou vous tuer. Une tension électrique est présente dans le boîtier, à moins que le principal dispositif de déconnexion de la machine soit en position hors tension.

- ▶ Ne procédez pas à l'entretien de la machine si vous n'êtes pas qualifié pour cela et autorisé à la faire. Vous devez bien comprendre les risques et comment les éviter.
- ▶ Respectez la norme de débranchement/verrouillage actuelle de l'OSHA lorsque les instructions d'entretien indiquent de procéder au débranchement/verrouillage. En dehors des États-Unis, respectez la norme de l'OSHA en l'absence de toute autre norme prioritaire.



**AVERTISSEMENT : Risques d'enchevêtrement et d'écrasement** — Tout contact avec des composants mobiles normalement isolés par des protections, capots et panneaux peut entraîner et écraser vos membres. Ces composants entrent en mouvement automatiquement.

- ▶ Ne procédez pas à l'entretien de la machine si vous n'êtes pas qualifié pour cela et autorisé à la faire. Vous devez bien comprendre les risques et comment les éviter.
- ▶ Respectez la norme de débranchement/verrouillage actuelle de l'OSHA lorsque les instructions d'entretien indiquent de procéder au débranchement/verrouillage. En dehors des États-Unis, respectez la norme de l'OSHA en l'absence de toute autre norme prioritaire.



**AVERTISSEMENT : Risques d'écrasement** — Machines à renversement uniquement—L'enceinte de la machine écrasera votre corps ou vos membres si elle descend ou tombe alors que vous vous trouvez au-dessous. L'enceinte peut descendre pendant la mise sous ou hors tension. L'actionnement manuel des vannes de renversement contourne les verrouillages de sécurité. Un actionnement incorrect des vannes de renversement manuelles peut faire descendre l'enceinte.

- ▶ Fixez les deux supports de sécurité rouges conformément aux instructions fournies, puis débranchez/verrouillez l'alimentation au niveau du principal dispositif de déconnexion de la machine avant de travailler sous la machine basculée.
- ▶ N'actionnez pas les vannes de renversement manuelles alors qu'une personne se trouve sous la machine.

- ▶ N'actionnez pas les commandes de renversement alors qu'une personne se trouve sous la machine.



**AVERTISSEMENT : Risques d'écrasement** — Machines à renversement avec cylindres à renversement avant et arrière—L'enceinte risque de tomber et d'avancer ou de reculer si les roues de renversement du côté qui ne s'incline pas sortent de leurs logements par le haut, même avec les supports de sécurité en place.

- ▶ Comprendre les conséquences d'une utilisation manuelle.



**AVERTISSEMENT : Risques liés aux espaces confinés** — Le confinement à l'intérieur du cylindre peut provoquer des blessures graves ou la mort. Les risques incluent, sans limitation, la panique, des brûlures, l'empoisonnement, la suffocation, un coup de chaleur, une contamination biologique, une électrocution et un écrasement.

- ▶ N'entrez pas dans le cylindre tant qu'il n'a pas été entièrement purgé, rincé, vidangé, refroidi et immobilisé.

BNWFBH01 / 2021344

BNWFBH01 0000684044

1/13/25, 8:12 AM Released

## 2.2 Utilisez les supports de sécurité rouges pour la maintenance — 48040F7B, 48040F7D

BNWFBH01.C02 0000684039 A.2 1/13/25, 8:12 AM Released

### 2.2.1 Supports de sécurité fournis et usage

BNWFBH01.C01 0000684042 A.2 1/13/25, 8:12 AM Released

Ces machines sont fournies avec deux chandelles de sécurité. Une fois le logement incliné vers l'avant ou vers l'arrière, selon les besoins, les chandelles sont placées sous les roues de renversement arrière ou avant relevées. La ou les chandelles de sécurité empêchent la descente sans alimentation du logement pendant la maintenance en cas de fuite dans le système d'inclinaison pneumatique. Une telle situation peut entraîner la chute brutale du logement. Utilisez les supports de sécurité dès lors que l'entretien à effectuer requiert que vous soyez placé physiquement dans ou à proximité de la trajectoire verticale de la partie mobile de la machine.



**AVERTISSEMENT : Utilisation incorrecte des chandelles de sécurité** — peut faire descendre la machine, qui peut vous écraser.

- ▶ Ne travaillez jamais à proximité de la trajectoire verticale de la partie mobile de la machine sans que les supports de sécurité soient déployés et que l'alimentation électrique soit coupée.
- ▶ Là où une paire de supports de sécurité est fournie, utilisez toujours les deux supports.
- ▶ Maintenez le ou les supports de sécurité en parfait état.

- ▶ Lorsqu'elles ne sont pas utilisées, rangez le ou les supports de sécurité à l'emplacement prévu sur la machine et dans un emplacement pratique désigné.

## 2.2.2 Déploiement des chandelles de sécurité

BNWFBH01.T01 0000684041 A.2 1/13/25, 8:12 AM Released

1. Utilisez les commandes pour redresser la machine comme pendant le fonctionnement normal.
2. Voir l'illustration côté droit. Placez chaque chandelle de sécurité sur sa plaque de montage sur la base d'inclinaison afin qu'elle repose bien en place. Passez par le côté proche de la machine.
3. Utilisez les commandes pour abaisser avec précaution le logement jusqu'à ce qu'il repose sur le ou les chandelles.
4. Coupez l'alimentation électrique de la machine.

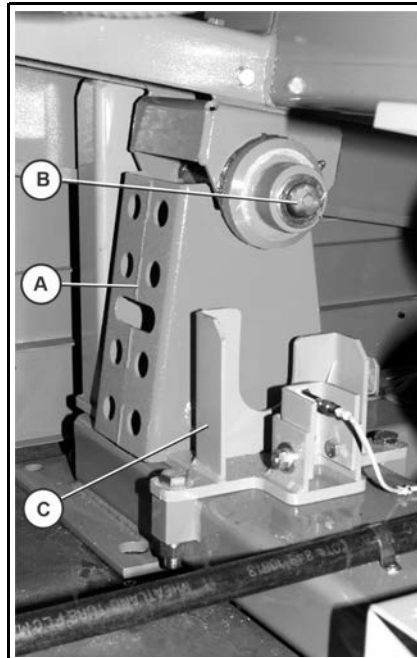

### Légende

- A . . . Chandelle de sécurité.** Utilisé à deux emplacements à l'avant ou deux emplacements à l'arrière.
- B . . . Roue de renversement**
- C . . . Logement**

BIWUUI03 / 2019296

BNUUUR02 0000582431 E.2 8/30/23, 2:31 PM Released

## 2.3 Prévention des dommages dus à des produits chimiques et à des systèmes de produits chimiques

BNUUUR02.C01 0000582416 A.2 B.2 E.2 8/30/23, 2:31 PM Released

Toutes les laveuses-essoreuses Milnor® et tous les tunnels de lavage CBW® utilisent de l'acier inoxydable conforme à la spécification ANSI 304. Ce matériau offre de bonnes performances lorsque les produits chimiques sont appliqués correctement. Ce matériau peut être endommagé en cas d'application incorrecte des produits chimiques. Les dommages peuvent être importants et survenir rapidement.

Généralement, les fournisseurs de produits chimiques :

- fournissent des systèmes de pompage pour alimenter la machine en produits chimiques ;
- raccordent le système de pompage de produits chimiques à la machine ;
- écrivent des formules de lavage qui contrôlent les concentrations en produits chimiques.

L'entreprise qui réalise ces procédures doit s'assurer qu'elles ne provoquent pas de dommages.

**Pellerin Milnor Corporation n'accepte aucune responsabilité pour les dommages chimiques sur ses machines ni sur le linge dans une machine.**

## 2.3.1 Comment les produits chimiques peuvent provoquer des dommages

BNUUUR02.R01 0000582433 A.2 B.2 E.2 8/30/23, 2:31 PM Released

**Formules de lavage et produits chimiques dangereux** — Voici quelques exemples susceptibles de provoquer des dommages :

- une très forte concentration d'agent de blanchiment au chlore ;
- un mélange d'acide et d'hypochlorite ;
- des produits chimiques (par exemple : agent de blanchiment au chlore, acide hydrofluorosilicique) qui restent sur l'acier inoxydable car ils ne sont pas rincés rapidement à l'eau.

Le livre "Textile Laundering Technology" « Technologie de lavage des textiles) de Charles L. Riggs fournit des renseignements sur les produits chimiques et les formules appropriés.

**Configuration ou raccordement incorrect des équipements** — De nombreux systèmes de produits chimiques :

- n'empêchent pas une aspiration dans le tube à produits chimiques (par exemple avec un casse-vide) lorsque la pompe ne tourne pas ;
- n'empêchent pas l'écoulement (par exemple avec une vanne) là où le tube à produits chimiques entre dans la machine.

Le passage de produits chimiques dans la machine alors que le système de produits chimiques est à l'arrêt entraînerait des dommages. Certaines configurations de composants peuvent laisser les produits chimiques passer dans la machine par un siphon ([Figure 2, page 15](#)). D'autres peuvent laisser les produits chimiques passer dans la machine par gravité ([Figure 3, page 16](#)).

**Figure 2. Configurations incorrectes qui laissent les produits chimiques passer dans la machine par un siphon**

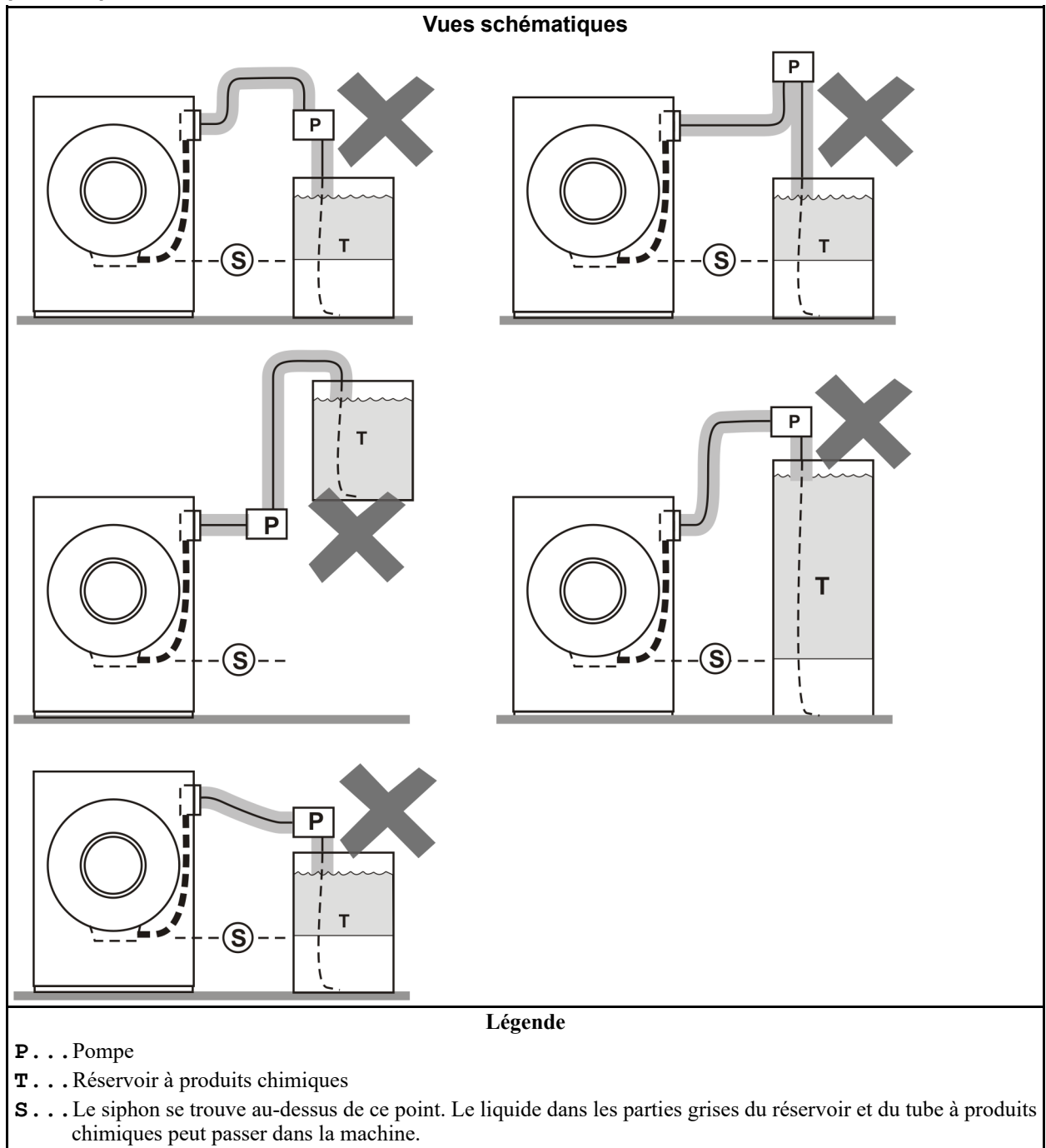
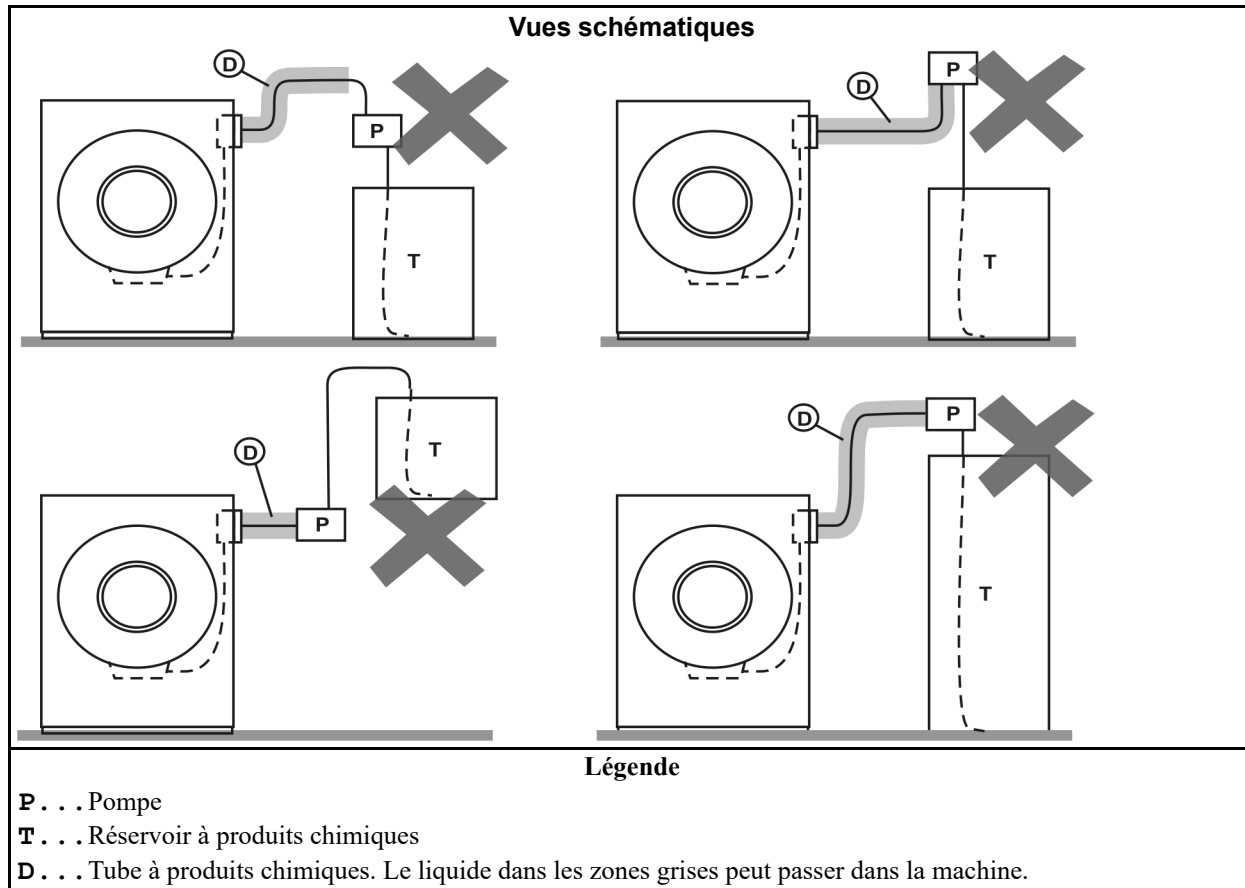



Figure 3. Configurations incorrectes qui laissent les produits chimiques passer dans la machine par gravité



## 2.3.2 Équipements et procédures permettant d'éviter des dommages

BNUUUR02.R02 0000582415 A.2 B.2 E.2 8/30/23, 2:31 PM Released

**Utilisez le collecteur de produits chimiques fourni.** — Il y a un collecteur sur la machine pour fixer les tubes de produits chimiques provenant d'un système de pompage pour produits chimiques. Le collecteur est équipé d'une source d'eau pour rincer les produits chimiques.

**Figure 4. Exemples de collecteurs pour tubes de produits chimiques. Votre équipement peut être différent.**

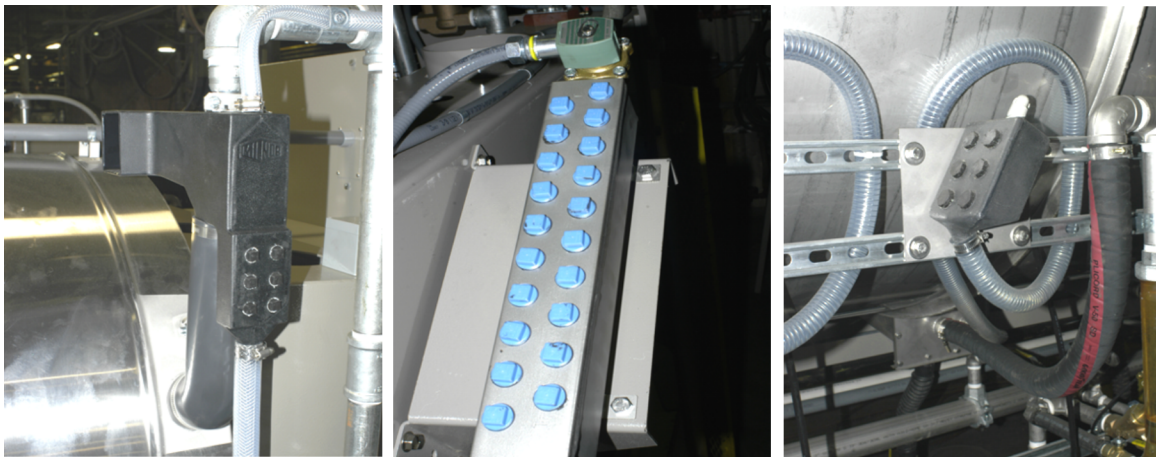

**Fermez le conduit.** — Si la pompe ne ferme pas toujours la conduite lorsqu'elle est arrêtée, utilisez une vanne d'arrêt pour cela.

**Ne laissez pas se produire une aspiration.** — Placez un casse-vide dans la conduite de produits chimiques, plus haut que le niveau plein du réservoir.

**Rincez à l'eau le tube de produits chimiques.** — Si le liquide qui reste dans le tube entre la pompe et la machine peut s'écouler dans la machine, rincez le tube à l'eau après l'arrêt de la pompe.

**Placez le tube de produits chimiques entièrement en dessous de l'entrée.** — Il ne doit par ailleurs y avoir aucune pression dans le réservoir ou le tube de produits chimiques alors que le système est arrêté.

**Figure 5. Une configuration qui empêche l'écoulement dans la machine lorsque la pompe est arrêtée (si le réservoir et le tube de produits chimiques ne présentent aucune pression)**

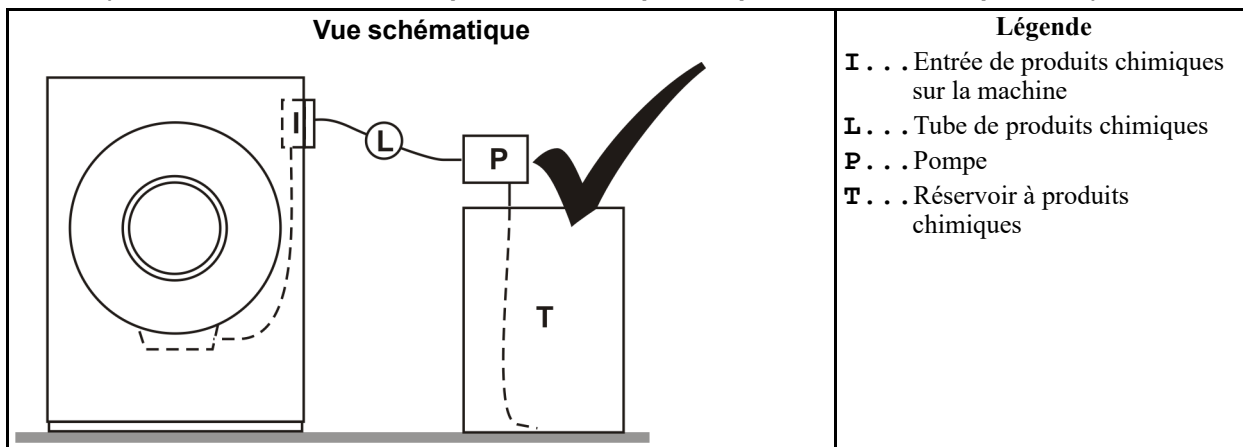

**Empêchez les fuites.** — Lorsque vous réalisez la maintenance sur le système de pompage de produits chimiques :

- Utilisez les bons composants.
- Assurez-vous que tous les raccordements soient adaptés.
- Veillez à ce que tous les raccords soient bien étanches.

# 3 Maintenance de routine

BNUUUH01 / 2022112

BNUUUH01 0000582426 H.2 8/30/23, 2:31 PM Released

## 3.1 Maintenance de routine

BIUUUM09.C01 A.2 H.2 Released

Effectuez l'entretien tel que décrit dans le [Section 3.1.1 : Résumé de l'entretien, page 19](#) afin de vous assurer que la machine est fiable, conforme à la garantie, et fonctionne correctement. Cet entretien réduit également les tâches de réparation et les arrêts indésirables. Si des réparations sont nécessaires, contactez votre revendeur ou le service d'assistance Milnor®.



**AVERTISSEMENT : les mécanismes** — peuvent happer des parties du corps et les mutiler.

- ▶ Ne procédez pas à l'entretien de la machine si vous n'êtes pas qualifié pour cela et autorisé à la faire. Vous devez bien comprendre les risques et comment les éviter.
- ▶ Ne réalisez pas l'entretien de la machine sous tension excepté si cela est indiqué explicitement dans les instructions d'entretien. Soyez extrêmement vigilant lorsque vous travaillez à proximité de composants mobiles.
- ▶ Remettez en place les protections et les capots que vous avez déposés pour l'entretien.

Si vous utilisez un logiciel pour gérer le planning des entretiens de votre usine, ajoutez les éléments présentés dans le résumé de l'entretien suivant à ce planning. Sinon, vous pouvez placer des repères dans un calendrier associé aux tableaux dans le résumé de l'entretien. Voir [Section 3.1.7 : Affichage de l'entretien dans un calendrier, page 29](#)

### 3.1.1 Résumé de l'entretien

BNUUUH01.R02 0000582440 A.2 H.2 8/30/23, 2:31 PM Released

Chacune des sections suivantes est un type d'entretien. Par exemple, la section « Protections et composants concernés » indique « Examinez ces articles. Si un composant est endommagé, manquant ou mal réglé, corrigez immédiatement le problème pour éviter une blessure. » Un tableau dans chaque section identifie les éléments applicables et la fréquence. La colonne « Plus de données » fournit des instructions particulières, si nécessaire.

\* Si la machine fonctionne plus de 12 heures chaque jour, traitez les éléments « journaliers » deux fois par jour. Traitez les autres éléments aux heures ou jours indiqués par le calendrier (voir la section 1). **Traitez tous les éléments de toutes les sections selon les intervalles d'entretien applicables (par exemple, jour, 40 à 60 heures, et 200 heures).**



**CONSEIL :** Le résumé de l'entretien comporte de nouveaux liens vers les sections qui suivent le résumé. Ces sections fournissent des informations supplémentaires sur les éléments d'entretien. Une fois que vous aurez pris connaissance de ces informations, vous devrez juste consulter le résumé pour effectuer l'entretien.

### 3.1.1.1 Protections et composants concernés

BNUUUH01.R09 0000582429 A.2 E.2 H.2 8/30/23, 2:31 PM Released

**Examinez ces articles. Si un composant est endommagé, manquant ou mal réglé, corrigez immédiatement le problème pour éviter une blessure.**

**Tableau 1. Protections et composants concernés**

Marque						À réaliser dans chaque cas	Composant	Plus de données
1	2	3	4	5	6			
x						jour*	protections, capots	Pour des composants de rechange, contactez votre revendeur ou Milnor.
x						jour*	plaque de sécurité	
		x				200 heures	fixations	Les fixations doivent être serrées.
x						jour*	chandelles, barres ou goupilles de sécurité (peintes en rouge)	Pour des composants de rechange, contactez votre revendeur ou Milnor. Voir la section « Utilisez les supports de sécurité rouges pour la maintenance... » du chapitre Sécurité.
		x				200 heures	boulons d'ancrage et joint	Le joint doit être intact. Les boulons doivent être serrés.
x						jour*	verrouillage de la porte	Si la machine fonctionne avec la porte ouverte : <ul style="list-style-type: none"> <li>• Coupez immédiatement l'alimentation électrique.</li> <li>• Interdisez l'utilisation.</li> <li>• Contactez votre revendeur ou Milnor.</li> </ul>
x						jour*	bouton d'arrêt d'urgence (en option sur certaines laveuses-essoreuses)	Voir <a href="#">Section 3.2.7</a> , page 39 Testez la commande.
			x			600 heures	frein mécanique	Voir <a href="#">Section 3.3.3</a> , page 42. Testez le frein mécanique. S'il ne fonctionne pas correctement, il doit être réparé. Contactez votre revendeur ou Milnor. Cela ne fait pas partie de l'entretien de routine.

### 3.1.1.2 Filtres, écrans et composants sensibles

BNUUUH01.R10 0000582424 A.2 E.2 H.2 8/30/23, 2:31 PM Released

**Supprimez la contamination de ces articles afin d'éviter des dommages et des performances médiocres.**

**Tableau 2. Filtres, écrans et composants sensibles**

Marque						À réaliser dans chaque cas	Composant	Plus de données. Voir également <a href="#">Section 3.1.2</a> , page 24
1	2	3	4	5	6			
	x					40 à 60 heures	ventilateur à inversion, événements, filtres	Voir <a href="#">Figure 9</a> , page 33. Maintenez un bon flux d'air.
			x			600 heures	moteurs	Maintenez un bon flux d'air.
					x	2400 heures	machine entière	Supprimez la poussière et la saleté en excès.

**Tableau 2 Filtres, écrans et composants sensibles (suite)**

Marque						À réaliser dans chaque cas	Composant	Plus de données. Voir également <a href="#">Section 3.1.2</a> , page 24
1	2	3	4	5	6			
x						jour*	zone d'entrée des produits chimiques	Certains produits chimiques restant sur les surfaces de la machine sont la cause d'une corrosion. Voir <a href="#">Section 3.2.3</a> , page 33 et <a href="#">Section 3.1.2</a> , page 24. Voir également, <a href="#">Section 2.3</a> , page 13 pour des informations de contexte.
x						jour*	filtre à purge automatique (et régulateur) pour air comprimé	Voir <a href="#">Figure 16</a> , page 37. Assurez-vous que le bol est purgé automatiquement.
		x				200 heures	élément filtrant pour le collecteur d'humidité	Remplacez le filtre si vous ne parvenez pas à le décontaminer.
				x		1200 heures	silencieux, soupapes d'échappement rapide	Voir <a href="#">Figure 17</a> , page 38
		x				200 heures	tamis pour arrivée d'air	Voir <a href="#">Figure 15</a> , page 36
					x	2400 heures	tamis dans le régulateur d'eau de l'injecteur d'alimentation optionnel et des produits chimiques sur certains modèles	Voir <a href="#">Figure 11</a> , page 34
		x				200 heures	tamis pour arrivée de vapeur (La vapeur est en option sur certains modèles.)	Voir <a href="#">Figure 14</a> , page 36
		x				200 heures	cellule photoélectrique de capteur de vitesse. En option sur certains modèles.	Voir <a href="#">Figure 18</a> , page 39
					x	2400 heures	détecteurs de proximité	Voir <a href="#">Figure 19</a> , page 39

### 3.1.1.3 Conteneurs de liquide

BNUUUH01.R11 0000582428 A.2 G.2 H.2 8/30/23, 2:31 PM Released

**Examinez ces articles. Ajoutez du liquide si nécessaire et maintenez les composants propres pour éviter tout dommage.**

**Tableau 3. Conteneurs de liquide**

Marque						À réaliser dans chaque cas	Composant	Plus de données. Voir également <a href="#">Section 3.1.3</a> : <a href="#">Identification du lubrifiant</a> , page 25
1	2	3	4	5	6			
		x				200 heures	Réservoir de frein à disque	Voir <a href="#">Figure 23</a> , page 44 Inspectez la qualité et le niveau de l'huile. Ajoutez de l'huile Dot3 ( <a href="#">Tableau 9</a> , page 25) si nécessaire. Si l'huile est contaminée, il est nécessaire de purger le système de frein. Contactez votre revendeur ou Milnor. Cela ne fait pas partie de l'entretien de routine.

### 3.1.1.4 Pièces d'usure

BNUUUH01.R12 0000582419 A.2 G.2 H.2 8/30/23, 2:31 PM Released

**Examinez ces articles. Resserrez ou remplacez l'article si nécessaire, afin d'éviter les arrêts et les performances médiocres. Pour des pièces de rechange, contactez votre revendeur.**

**Tableau 4. Pièces d'usure**

Marque						À réaliser dans chaque cas	Composant	Plus de données
1	2	3	4	5	6			
		x				200 heures	poulies et courroies de transmission	Voir <a href="#">Section 3.2.1</a> , page 31
		x				200 heures	conduites et tuyaux (non hydrauliques)	Examinez les tuyaux et leurs branchements à la recherche de fuites.
		x				200 heures	sacs à air d'inclinaison	Voir <a href="#">Figure 17</a> , page 38
				x		1200 heures	amortisseurs de porte	Remplacez en cas de dommage.
		x				200 heures	ressorts en caoutchouc	Voir <a href="#">Figure 24</a> , page 45
		x				200 heures	amortisseurs	Voir <a href="#">Section 3.3.4</a> , page 44
				x		1200 heures	butoirs d'inclinaison	Voir <a href="#">Figure 22</a> , page 42. Examiner. Remplacez en cas d'endommagement ou d'usure.

### 3.1.1.5 Paliers et bagues

BNUUUH01.R13 0000582420 A.2 F.2 H.2 8/30/23, 2:31 PM Released

À moins que l'article soit étanche, injectez de la graisse pour éviter tout dommage. Voir la section suivante pour les moteurs.

**Tableau 5. Paliers et bagues**

Marque						À réaliser dans chaque cas	Composant	Plus de données . Voir également <a href="#">Section 3.1.3</a> , page 25
1	2	3	4	5	6			
Plaque de graissage 01 10025Y du logement de palier. Utilisez ces données si votre machine est équipée de cette plaque de graissage. Voir <a href="#">Figure 20</a> , page 41 et <a href="#">Section 3.1.5</a> , page 26. Sur certains modèles, il est nécessaire de retirer un panneau latéral pour accéder à cette plaque de graissage.								
		x				200 heures	joint	Ajoutez 0,12 once (3,6 ml) de graisse EPLF2 ( <a href="#">Tableau 9</a> , page 25)
		x				200 heures	palier arrière	Ajoutez 0,3 once (9,0 ml) de graisse EPLF2
		x				200 heures	palier avant	Ajoutez 0,3 once (9,0 ml) de graisse EPLF2
Autres orifices de graissage								
		x				200 heures	bagues de porte hydrauliques	<a href="#">Figure 21</a> , page 42. Ajoutez 0,06 once (1,8 ml) de graisse EPLF2 ( <a href="#">Identification du lubrifiant</a> )
		x				200 heures	charnière de porte	<a href="#">Figure 21</a> , page 42. Ajoutez 0,12 once (3,6 ml) de graisse EPLF2 ( <a href="#">Tableau 9</a> , page 25).
		x				200 heures	plongeur de verrou de porte	<a href="#">Figure 21</a> , page 42. Appliquez la barre DE3 ( <a href="#">Tableau 9</a> , page 25) à la surface.
		x				200 heures	plongeur d'ouverture de porte	<a href="#">Figure 21</a> , page 42. Appliquez la barre DE3 ( <a href="#">Tableau 9</a> , page 25) à la surface.
		x				200 heures	pivots d'inclinaison	<a href="#">Figure 22</a> , page 42 Ajoutez 0,06 once (1,8 ml) de graisse EPLF2 ( <a href="#">Tableau 9</a> , page 25).
				x		600 heures	paliers de moteur	Voir <a href="#">Section 3.1.6</a> : Procédures pour les moteurs, page 27
				x		600 heures	paliers à bride	Voir <a href="#">Cette rubrique apparaît ailleurs dans le document Milnor BNRUUH01</a> Ajoutez 0,12 once (3,54 ml) de graisse EPLF2 à quatre endroits.
				x		600 heures	chaîne de palan	Voir <a href="#">Cette rubrique apparaît ailleurs dans le document Milnor BNRUUH01</a> . Appliquez du spray lubrifiant FGL ( <a href="#">Tableau 9</a> , page 25).

### 3.1.1.6 Planning de graissage du moteur

BNUUUH01.R15 0000582447 A.2 H.2 8/30/23, 2:31 PM Released

Utilisez les données du [Tableau 10: Quantités et intervalles de graissage du moteur, page 29](#) pour remplir ce tableau.

**Tableau 6. Planning de graissage du moteur**

Identification du moteur (exemple : entraînement principal)	Intervalle		Quantité		Dates des ajouts de graisse								
	Années	Heures	fl oz	ml									

### 3.1.1.7 Mécanismes et réglages

BNUUUH01.R14 0000582412 A.2 G.2 H.2 8/30/23, 2:31 PM Released

Vérifiez si les mécanismes sont opérationnels et si les réglages sont corrects pour éviter tout risque de performances médiocres.

**Tableau 7. Mécanismes et réglages**

Marque						À réaliser dans chaque cas	Composant	Plus de données
1	2	3	4	5	6			
					x	2400 heures	circuit de contrôle	Inspectez le câblage et les branchements des boîtiers électriques. Recherchez des traces de corrosion, des branchements desserrés. Voir <a href="#">Section 3.1.2, page 24</a>
		x				200 heures	régulateur de pression d'eau de l'injecteur d'alimentation optionnel	Voir <a href="#">Figure 11, page 34</a> . Valeur : 28 PSI (193 kPa)
		x				200 heures	régulateur de pression d'eau de rinçage des produits chimiques	Voir <a href="#">Figure 13, page 35</a> . Valeur : 28 PSI (193 kPa)
		x				200 heures	mécanismes à air comprimé	Voir <a href="#">Section 3.2.5, page 36</a>
		x				200 heures	capteur de niveau de bain utilisant la pression d'air	Inspectez la conduite d'air et les raccordements. Voir <a href="#">Figure 12, page 35</a>
		x				200 heures	pression d'air du logement de palier	Voir <a href="#">Figure 16, page 37</a> Valeur : 10 PSI (69 kPa)



### 3.1.2 Comment décontaminer

BNUUUH01.R03 0000582505 A.2 H.2 8/30/23, 2:31 PM Released

**Tableau 8. Types de contamination, agents de nettoyage et procédures**

Matériel ou composant	Contamination courante	Exemple	Agent de nettoyage	Plus de données
enceinte de la machine	poussière, saleté	—	air comprimé ou aspirateur d'atelier	Air—pas plus de 30 psi (207 kpa). Prenez soin de ne pas envoyer la poussière dans les mécanismes.
ailettes et événements des composants électriques	poussière	moteurs, inverseurs, résistances de freinage	aspirateur d'atelier, brosse à poils souples, jet d'air pour les composants électriques	Prenez soin de ne pas envoyer la poussière dans les mécanismes.
intérieur de boîtier électrique	poussière	tous les boîtiers électriques		
branchements électriques	corrosion, vernis	connecteur débrochable, connecteur Molex, relais embrochable	solvant en vaporisateur pour composants électriques	Débranchez, puis rebranchez. Utilisez du solvant si le mauvais branchement persiste.
capteurs électroniques	poussière	cellule photoélectrique, réflecteur, laser, détecteur de proximité, sonde de température	aucun(e)	Utilisez un chiffon propre, doux et sec.
	saleté		eau tiède avec savon, puis rinçage à l'eau	Utilisez des chiffons propres et doux.
acier inoxydable	éclaboussures de produits chimiques	enveloppe, injecteur d'alimentation	eau	Utilisez un tuyau pour rincer les traces de produits chimiques de l'ensemble de la surface. Évitez le mouiller les composants électriques ou les mécanismes.
acier inoxydable série 300	attaque corrosive des produits chimiques	enveloppe interne, cylindre	décapage et passivation	Contactez votre revendeur ou Milnor. Cela ne fait pas partie de l'entretien de routine.
métal peint, aluminium non peint	poussière, saleté, graisse	éléments du châssis	eau tiède avec savon, puis rinçage à l'eau	Utilisez des chiffons propres. Évitez le mouiller les composants électriques.
caoutchouc	saleté, huile, graisse	courroies d'entraînement, tuyaux	eau tiède avec savon, puis rinçage à l'eau	Utilisez des chiffons propres. Procédez à un rinçage complet. Éliminez toute trace d'huile ou de savon des courroies d'entraînement. Vérifiez que les courroies d'entraînement sont opérationnelles.
plastique transparent, acrylique	décoloration (jaunissement)	bol de filtre à air comprimé, débitmètre visuel	eau tiède avec savon, ensuite rinçage à l'eau, puis nettoyant pour acrylique N'utilisez pas d'ammoniac.	Utilisez uniquement les agents de nettoyage nécessaires. Lavez et rincez avec des chiffons propres et doux. Suivez les instructions fournies avec le nettoyant pour acrylique.
vitre en verre	décoloration (jaunissement)	vitre de porte, jauge visuelle	solution d'eau et d'ammoniac, ensuite rinçage à l'eau puis acétone	Utilisez des chiffons propres et doux. Utilisez uniquement les agents de nettoyage nécessaires. Si nécessaire, faites tremper dans la solution de nettoyage.
filtre à air fin, filtre à peluches	poussière, peluches	volet du boîtier électrique de l'inverseur, bol de	aspirateur d'atelier	Remplacez le filtre usagé par un filtre neuf lorsque l'aspirateur ne peut pas éliminer la contamination.

**Tableau 8 Types de contamination, agents de nettoyage et procédures (suite)**

Matériel ou composant	Contamination courante	Exemple	Agent de nettoyage	Plus de données
		filtre de la conduite d'air, séchoirs		
tamis rigides, écrans pour l'eau, la vapeur	particules minérales	dans la conduite d'eau, le tamis en y	eau	Utilisez une brosse à poils rigides. Rincez à l'eau courante.
tamis rigides, écrans pour l'huile	rognures de métal	dans le circuit hydraulique	nettoyant pour carburateur ou solvant équivalent	Faites tremper. Utilisez une brosse à poils rigides.
composants de transmission en acier	saleté, lubrifiant solidifié	paliers, chaînes de roulement, pignons, engrenages	nettoyant pour carburateur ou solvant équivalent	Faites tremper. Utilisez un chiffon ou une brosse à poils souples.

### 3.1.3 Identification du lubrifiant

BNUUUH01.R04 0000582413 A.2 D.2 H.2 8/30/23, 2:31 PM Released

Le tableau ci-dessous identifie le lubrifiant pour chaque code de lubrifiant donné dans le résumé de l'entretien. Vous les obtiendrez, ou leur équivalent, auprès de votre fournisseur local de lubrifiants.

Lorsque vous ajoutez de la graisse, suivez toujours les procédures indiquées sous [Section 3.1.4 : Procédures de graissage au pistolet, page 26](#). Lorsque vous ajoutez de la graisse à des moteurs, suivez aussi les procédures indiquées sous [Section 3.1.6 : Procédures pour les moteurs, page 27](#).

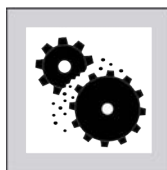

**ATTENTION : Un lubrifiant inapproprié** — diminue la durée de vie des composants.

- ▶ Assurez-vous que tout l'équipement et les accessoires utilisés pour appliquer des lubrifiants sont propres.
- ▶ Utilisez uniquement les lubrifiants indiqués ou des équivalents ayant les mêmes caractéristiques.

**Tableau 9. Identification du lubrifiant**

Code	Type	Nom de la marque	Exemple d'application
EM	graisse	Mobil Polyrex EM ou comme indiqué sur la plaque signalétique du moteur	paliers de moteur
EPLF2	graisse	Shell Alvania EP (LF) type 2	paliers et bagues de l'axe d'entraînement, joints à billes, chaîne de transmission
DOT3	huile	NAPA Super Heavy Duty Brake Fluid DOT 3	freins à disque
23	huile	Shell Tellus 23	lubrificateur de conduite d'air
DE3	barre	AGS Door-Ease DE-3	plongeur de verrou de porte

### 3.1.4 Procédures de graissage au pistolet

BNUUUH01.R05 0000582475 A.2 H.2 8/30/23, 2:31 PM Released

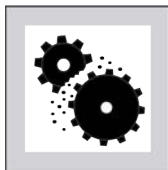

**ATTENTION : la pression hydraulique** — risque de déplacer les joints et d'introduire de la graisse dans des zones indésirables (exemple : bobinage moteur).

- ▶ Utilisez un pistolet graisseur à main. Un pistolet graisseur à moteur produit trop de pression.
- ▶ Sachez quelle quantité de graisse est délivrée par votre pistolet lors de chaque cycle (chaque dose).
- ▶ Utilisez le pistolet graisseur à vitesse lente (10 à 12 secondes par cycle).
- ▶ Ajoutez seulement la quantité de graisse spécifiée. Arrêtez si de la graisse propre émerge d'un orifice de vidange ou autre orifice.
- ▶ Essuyez les écoulements de graisse sur les courroies et les poulies.

Les tableaux indiquent les quantités de graisse en millilitres (ml) et en onces liquides (fl oz). Vous pouvez également utiliser les cycles (doses) d'un pistolet graisseur. Un cycle correspond à chaque activation du déclencheur. Un cycle délivre généralement 1,8 ml (0,06 fl oz) environ. Votre pistolet graisseur peut donner plus ou moins que cette quantité. Mesurez la dose délivrée par votre pistolet graisseur comme suit :

- Vérifiez que le pistolet graisseur fonctionne correctement.
- Utilisez-le pour injecter de la graisse dans un petit conteneur gradué en millilitres ou en onces liquides. Activez le déclencheur lentement et à fond.
- Injectez une quantité de graisse suffisante pour obtenir une mesure précise. Comptez le nombre de cycles effectués avec le pistolet graisseur (le nombre de fois où vous l'avez déclenché).
- Calculez la quantité délivrée par chaque cycle du pistolet graisseur, comme dans les exemples suivants.

*Exemple : 2 fl oz/64 cycles = 0,031 fl oz pour chaque cycle*

*Exemple : 59 ml/64 cycles = 0,92 ml pour chaque cycle*

### 3.1.5 Procédures pour composants de palier reliés à une plaque de graissage

BNUUUH01.R06 0000582455 A.2 H.2 8/30/23, 2:31 PM Released

Votre machine possède une plaque de graissage sur l'enceinte ou l'enveloppe de la machine. Vous ajoutez de la graisse aux composants du logement de palier à cet emplacement. La procédure correcte consiste à ajouter de la graisse lorsque le cylindre tourne à la vitesse de lavage tout en suivant ces consignes :

- Pour toutes les autres opérations de graissage, ajoutez la graisse après avoir coupé l'alimentation électrique de la machine.

- Si la plaque de graissage de votre machine n'est pas opérationnelle (si vous devez ajouter de la graisse à un autre emplacement), ajoutez la graisse après avoir coupé l'alimentation électrique de la machine.
- Si vous devez retirer une protection pour avoir accès à la plaque de graissage, empêchez tout accès à la machine par d'autres membres du personnel.

Si vous suivez ces consignes, utilisez le mode **Manuel** pour mettre la machine à la vitesse de lavage. Ensuite, ajoutez la graisse à la plaque de graissage.

### 3.1.6 Procédures pour les moteurs

BNUUUH01.R07 0000582432 A.2 B.2 H.2 8/30/23, 2:31 PM Released



**AVIS :** Les garanties des moteurs et les procédures de maintenance nécessaires pour conserver la garantie du moteur sont définies par le fabricant d'origine, pas par Milnor®. Consultez la plaque signalétique du moteur et le manuel du fabricant. Lorsque les informations suivantes ne sont pas en contradiction avec les instructions du fabricant, vous pouvez les utiliser pour définir un planning de lubrification pour les moteurs qui doivent être lubrifiés.



Si le moteur de votre machine ne possède pas de raccords graisseurs, aucun entretien de graissage n'est nécessaire. Dans le cas contraire, il est nécessaire d'ajouter de la graisse. L'intervalle est cependant plus long que celui des autres entretiens. [Tableau 10: Quantités et intervalles de graissage du moteur, page 29](#) indique les intervalles de graissage du moteur, et les quantités en fonction des tailles de châssis et des vitesses de moteur spécifiées. Ces données vous sont fournies par la plaque signalétique du moteur. Utilisez [Tableau 6: Planning de graissage du moteur, page 23](#) pour enregistrer les données concernant les moteurs de votre machine.



**ATTENTION :** Le maintien en place des bouchons de vidange de la graisse — peut entraîner la pénétration de graisse dans les bobinages et faire griller le moteur.

- ▶ Si le moteur possède des bouchons de vidange, retirez-les avant d'ajouter de la graisse. Si le moteur possède des raccords de décharge de la graisse, il n'est pas nécessaire de les retirer.

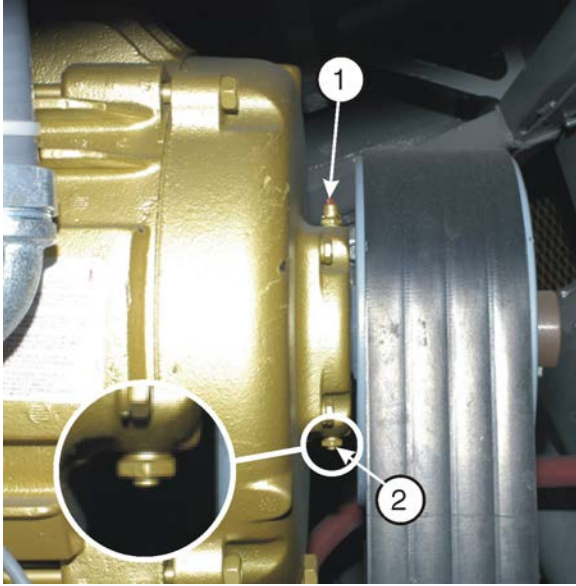
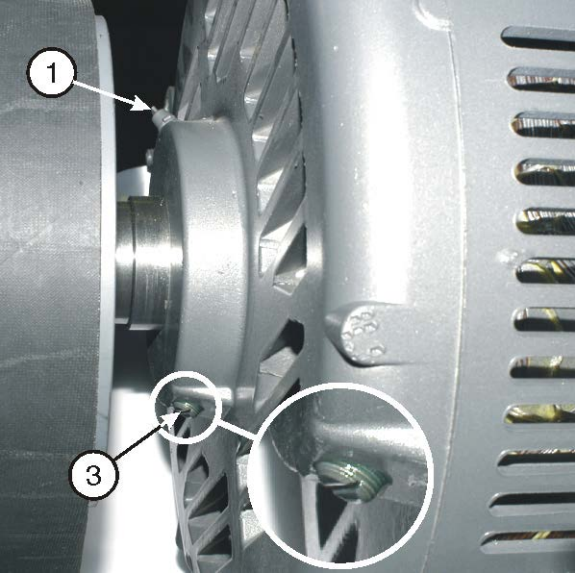
Figure 6. Conditions de lubrification du moteur

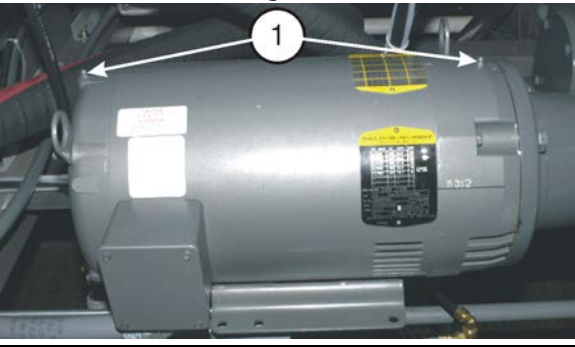
<p><b>Raccord graisseur et décharge de la graisse</b></p> 	<p><b>Raccord graisseur et vidange de la graisse</b></p> 																																								
<p><b>Plaque signalétique du moteur</b></p>  <table border="1" data-bbox="267 1081 625 1312"> <thead> <tr> <th>FIG.</th> <th>VOLTS</th> <th>HZ.</th> <th>AMPS</th> <th>CODE</th> </tr> </thead> <tbody> <tr> <td>A/220</td> <td>50</td> <td>56</td> <td>L</td> <td></td> </tr> <tr> <td>B/380</td> <td>50</td> <td>31.3</td> <td>L</td> <td></td> </tr> <tr> <td>C/440</td> <td>50</td> <td>28</td> <td>L</td> <td></td> </tr> <tr> <td>A/240</td> <td>60</td> <td>48</td> <td>L</td> <td></td> </tr> <tr> <td>C/480</td> <td>60</td> <td>24</td> <td>L</td> <td></td> </tr> <tr> <td></td> <td></td> <td></td> <td></td> <td></td> </tr> <tr> <td></td> <td></td> <td></td> <td></td> <td></td> </tr> </tbody> </table> <p>RPM (50/60) 1465 / 1765</p> <p>REF. 20 SER. Z1102211931</p> <p>STK. NO. 39GB40AATD DUTY CONT</p> <p>SPEC. 09EB22Z707G1 SER. F. 1.00</p> <p>FRAME 256T DES A CLASS F</p> <p>100 010A NE EFF 93 PF 81</p> <p>BALDOR ELECTRIC CO. FT. SMITH, AR MFG. IN U.S.A.</p> <p>NP2495L</p>	FIG.	VOLTS	HZ.	AMPS	CODE	A/220	50	56	L		B/380	50	31.3	L		C/440	50	28	L		A/240	60	48	L		C/480	60	24	L												<p><b>Raccords graisseurs, sans décharges ni vidanges</b></p>  <p><b>Légende</b></p> <p>1 . . . Raccord graisseur</p> <p>2 . . . Décharge de la graisse. Ne pas retirer.</p> <p>3 . . . Bouchon de vidange de la graisse. Retirer en premier.</p> <p>4 . . . RPM (vitesse du moteur). Dans cet exemple, la vitesse est de 1465 RPM à 50 Hz et de 1765 RPM à 60 Hz.</p> <p>5 . . . Taille du châssis NEMA (CEI). Exemple : 256T</p>
FIG.	VOLTS	HZ.	AMPS	CODE																																					
A/220	50	56	L																																						
B/380	50	31.3	L																																						
C/440	50	28	L																																						
A/240	60	48	L																																						
C/480	60	24	L																																						

Injectez de la graisse de la façon suivante :

1. Faites fonctionner la machine, ou utilisez les fonctions manuelles pour faire tourner le moteur jusqu'à ce qu'il soit chaud.
2. Coupez l'alimentation électrique de la machine.
3. Si le moteur possède des bouchons de vidange de la graisse, retirez-les. Consultez la mise en garde ci-dessus.

4. Injectez de la graisse EM ([Tableau 9: Identification du lubrifiant, page 25](#)) avec le moteur à l'arrêt. Si le moteur dont la plaque signalétique est représentée à la figure ci-dessus fonctionne à 60 Hz, la quantité de graisse spécifiée pour chaque raccord graisseur est de 0,65 once (18,4 ml).
5. Si le moteur possède des bouchons de vidange de la graisse, faites fonctionner la machine ou utilisez les fonctions manuelles pour faire tourner le moteur pendant deux heures. Remettez le bouchon de vidange en place.

**Tableau 10. Quantités et intervalles de graissage du moteur**

Sur la plaque signalétique du moteur (voir la <a href="#">Figure 6: Conditions de lubrification du moteur, page 28</a> )		Intervalle		Quantité	
Taille du châssis NEMA (CEI)	RPM supérieur ou égal à	Années	Heures	Onces liquides	ml
Jusqu'à 210 (132)	900	5,5	11000	0,34	9,5
	1200	4,5	9000		
	1800	3	6000		
	3600	1,5	3000		
>210 à 280 (132 à 180)	900	4,5	9000	0,65	18,4
	1200	3,5	7000		
	1800	2,5	5000		
	3600	1	2000		
>280 à 360 (180 à 200)	900	3,5	7000	0,87	24,6
	1200	3	6000		
	1800	2	4000		
	3600	0,5	1000		
>360 à 5000 (200 à 300)	900	2,5	5000	2,23	63,2
	1200	2	4000		
	1800	1	2000		
	3600	0,5	1000		

### 3.1.7 Affichage de l'entretien dans un calendrier

BNUUUH01.R01 0000582478 A.2 H.2 8/30/23, 2:31 PM Released

Vous pouvez placer des repères dans un calendrier associé aux tableaux de la [Section 3.1.1, page 19](#). Les repères sont les numéros 2, 3, 4, 5 et 6. Il n'est pas nécessaire d'afficher le numéro 1 (éléments que vous traitez chaque jour) dans le calendrier. Numéro 2 = éléments traités toutes les 40 à 60 heures, 3 = toutes les 200 heures, 4 = toutes les 600 heures, 5 = toutes les 1200 heures, et 6 = toutes les 2400 heures. Ce sont les numéros sous Marquage, en haut des colonnes étroites situées à gauche de chaque tableau de la [Section 3.1.1, page 19](#).

Le tableau ci-dessous indique où placer les repères sur un calendrier. Par exemple, si votre machine fonctionne entre 41 et 60 heures par semaine, les trois premiers repères sont 2, 2 et 3. Placez ces repères sur les première, deuxième et troisième semaines qui suivent le début de fonctionnement de la machine. Si vous effectuez l'entretien de routine un certain jour de la

semaine, placez le repère sur ce jour de chaque semaine. Poursuivez la mise en place des repères sur les semaines suivantes. **Il peut s'avérer nécessaire d'effectuer l'entretien des 40 à 60 heures (2) plus d'une fois par semaine.** Si la machine fonctionne entre 61 et 100 heures, placez un 2 sur deux jours de la semaine. Si la machine fonctionne 101 heures ou plus, placez un 2 sur trois jours de la semaine.

Pour chaque date avec le repère 3, traitez les éléments marqués d'un x dans la colonne 3 ou 2 de chaque tableau de la [Section 3.1.1 , page 19](#). Pour chaque date avec le repère 4, traitez les éléments marqués d'un x dans la colonne 4, 3 ou 2. Continuez sur ce modèle.

**Tableau 11. Placement des repères dans un calendrier**

Heures/ Semaine	Numéro de semaine																													
	1	2	3	4	5	6	7	8	9	10	11	12	13	14	15	16	17	18	19	20	21	22	23	24	25	26	27	28	29	30
Jusqu'à 40	2	2	2	2	3	2	2	2	2	3	2	2	2	2	4	2	2	2	2	3	2	2	2	2	3	2	2	2	2	5
41 - 60	2	2	3	2	2	2	3	2	2	4	2	2	3	2	2	2	3	2	2	5	2	2	3	2	2	2	3	2	2	4
61 - 80	2	2	3	2	3	2	4	2	2	3	2	2	3	2	5	2	3	2	2	3	2	4	2	2	3	2	2	3	2	6
81 - 100	2	3	2	3	2	4	2	3	2	3	2	5	2	3	2	3	2	4	2	3	2	3	2	6	répéter					
101 - 120	2	3	2	3	4	2	3	2	3	5	2	3	2	3	4	2	3	2	3	6	répéter									
121 - 140	2	3	2	3	4	3	2	3	5	2	3	2	3	4	3	2	3	6	répéter											
Heures/ Semaine	Numéro de semaine, suite																													
	31	32	33	34	35	36	37	38	39	40	41	42	43	44	45	46	47	48	49	50	51	52	53	54	55	56	57	58	59	60
Jusqu'à 40	2	2	2	2	3	2	2	2	2	3	2	2	2	2	4	2	2	2	2	3	2	2	2	2	3	2	2	2	2	6
41 - 60	2	2	3	2	2	2	3	2	2	6	répéter																			

BNWUUH01 / 2021514

BNWUUH01 0000582423 G.2 8/30/23, 2:31 PM Released

## 3.2 Composants de maintenance—Groupes machines et commandes

BNWUUH01.C01 0000582437 A.2 G.2 8/30/23, 2:31 PM Released

### 3.2.1 Examen des courroies en V et des poulies

BNWUUH01.C02 0000582418 A.2 B.2 G.2 8/30/23, 2:31 PM Released

Figure 7. Conditions des courroies et des poulies à contrôler

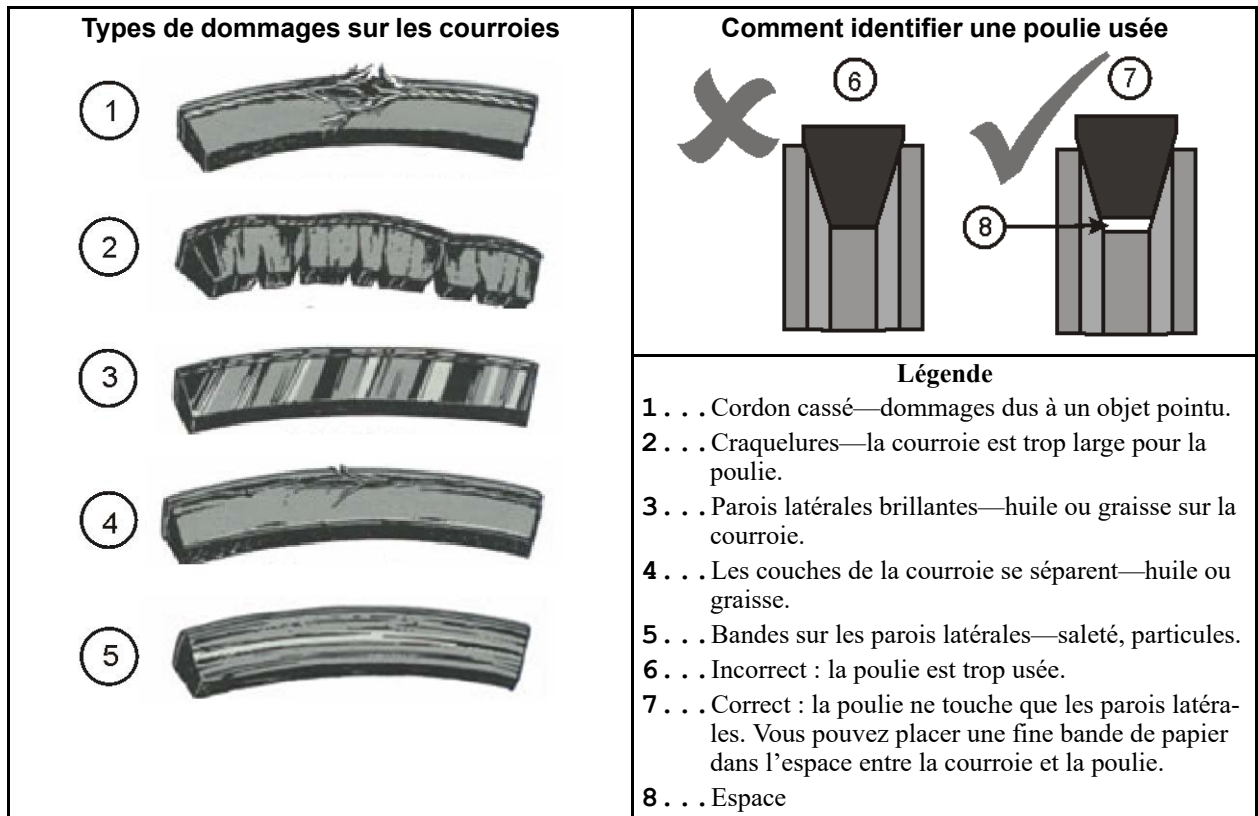

#### L'alimentation électrique étant coupée :

- Recherchez des saletés, de la poussière, de l'huile et de la graisse. Décontaminez.
- Recherchez les dommages sur la bande comme illustré sur la figure ci-dessus.
- Recherchez des poulies usées comme illustré sur la figure ci-dessus.

#### La machine étant en fonctionnement—Ne touchez pas la machine. Regardez et écoutez :

- Une courroie peut vibrer et provoquer des dommages. Cette condition ne doit être corrigée que si les vibrations sont importantes.
- La tension d'une courroie doit être suffisante pour que celle-ci ne patine pas sur la poulie pendant le fonctionnement. Le patinage est généralement identifiable à son bruit.

**À propos du remplacement de composants et de l'ajustement de la tension**—Un ajustement correct est très important pour la durée de vie des composants et la fonctionnement de la machine. Votre revendeur Milnor® peut réaliser ce travail. Si vous savez comment réaliser ce travail (par



exemple, aligner correctement les courroies et les poulies) et voulez le faire, contactez votre revendeur ou Milnor® pour connaître les références. Remplacez les composants usés avant de régler la tension.

- Machines qui utilisent des tiges entièrement filetées et des écrous pour maintenir en place la base du moteur—Faites tourner les boulons sur les tiges pour ajuster la tension. Serrez les écrous.
- Machines qui utilisent un ressort pour maintenir la tension sur la base du moteur—Utilisez le manchon de tension de la courroie fourni avec la machine. Placez le manchon sur la tige sur laquelle est fixé le ressort, ou retirez le manchon pour augmenter ou réduire la tension (voir la figure ci-dessous). Remplacez le ressort si nécessaire.

**Figure 8. Comment régler la tension de la courroie sur une machine qui utilise la tension du ressort**

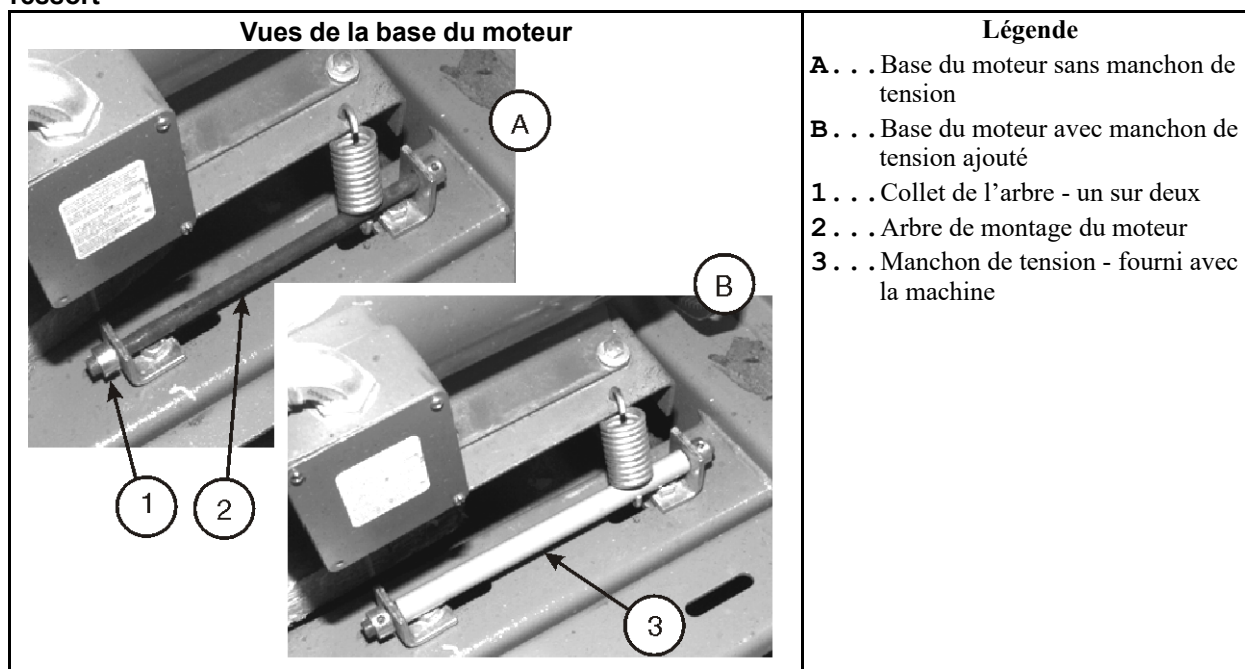

### 3.2.2 Inverseurs

BNWUUH01.C08 0000582504 A.2 G.2 8/30/23, 2:31 PM Released

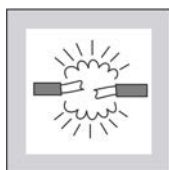

**ATTENTION : un débit d'air insuffisant** — peut faire griller l'inverseur.

- ▶ Les ventilateurs, le filtre, les événements et les résistances de freinage doivent rester propres.

Figure 9. Boîtier électrique et inverseur Il s'agit d'exemples. Votre machine peut être différente.

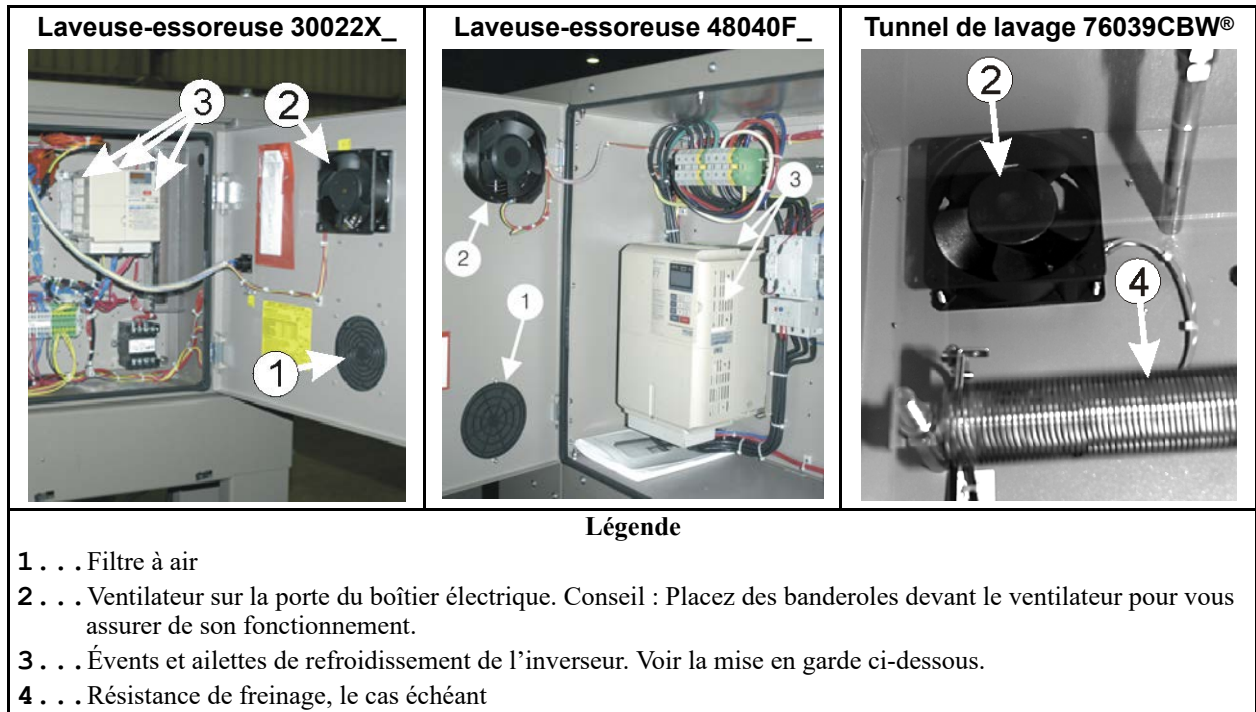

### 3.2.3 Dispositifs chimiques

BNWUUH01.C09 0000582495 A.2 G.2 8/30/23, 2:31 PM Released



**ATTENTION : Corrosion chimique** — peut endommager la machine et le linge.

- ▶ Ne raccordez les tubes de produits chimiques qu'aux entrées de collecteurs de produits chimiques.
- ▶ Arrêtez les fuites. Éliminez des surfaces les produits qui ont fui.
- ▶ Contactez votre revendeur ou Milnor® si vous voyez des dommages dus à la corrosion.



**ATTENTION : une forte pression d'eau** — peut entraîner des éclaboussures de produits chimiques de laverie sur le personnel et sur les surfaces des machines.

- ▶ Veillez à ce que la pression soit réglée comme indiqué dans le résumé de l'entretien.

**Figure 10. Collecteurs d'entrée de produits chimiques pour les systèmes de pompage de produits chimiques. Voir la mise en garde ci-dessous. Il s'agit d'exemples. Votre machine peut être différente.**

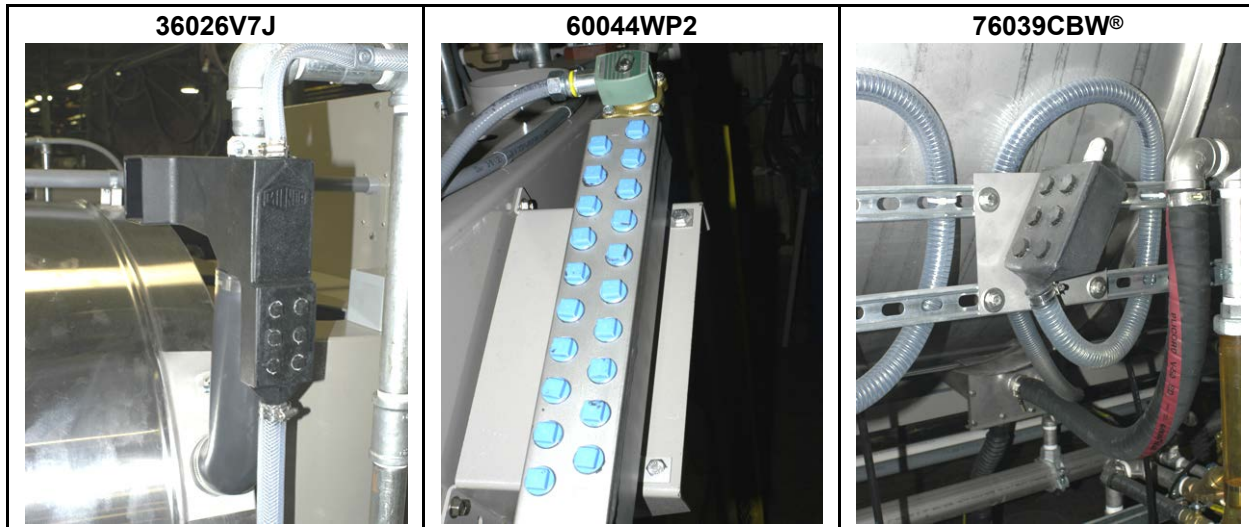
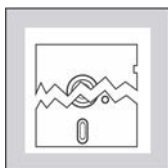

**Figure 11. Trémie à savon et injecteur d'alimentation à 5 compartiments en option. Il s'agit d'exemples. Votre machine peut être différente.**

<p><b>Trémie à savon</b></p>	<p><b>Injecteur d'alimentation</b></p>	<p><b>Composants de réglage de l'eau de rinçage</b></p>
<p style="text-align: center;"><b>Légende</b></p> <p>1 . . . Ne laissez pas les produits chimiques rester sur les surfaces.                  2 . . . Régulateur de pression d'eau. Voir la mise en garde ci-dessous.                  3 . . . Vis de réglage                  4 . . . Jauge de pression d'eau                  5 . . . Tamis intérieur</p>		

### 3.2.4 Dispositifs à eau et à vapeur

BNWUUH01.C10 0000582421 A.2 D.2 G.2 8/30/23, 2:31 PM Released



**ATTENTION : Débit d'air restreint** — peut faire apparaître des valeurs de niveau incorrectes.

- ▶ Veillez à ce que le tuyau ou tube de raccordement reste exempt de blocages et de fuites.
- ▶ Veillez à ce que les raccords soient bien étanches.

Figure 12. Tube d'air pour le capteur de niveau d'eau. Il s'agit d'exemples. Votre machine peut être différente.

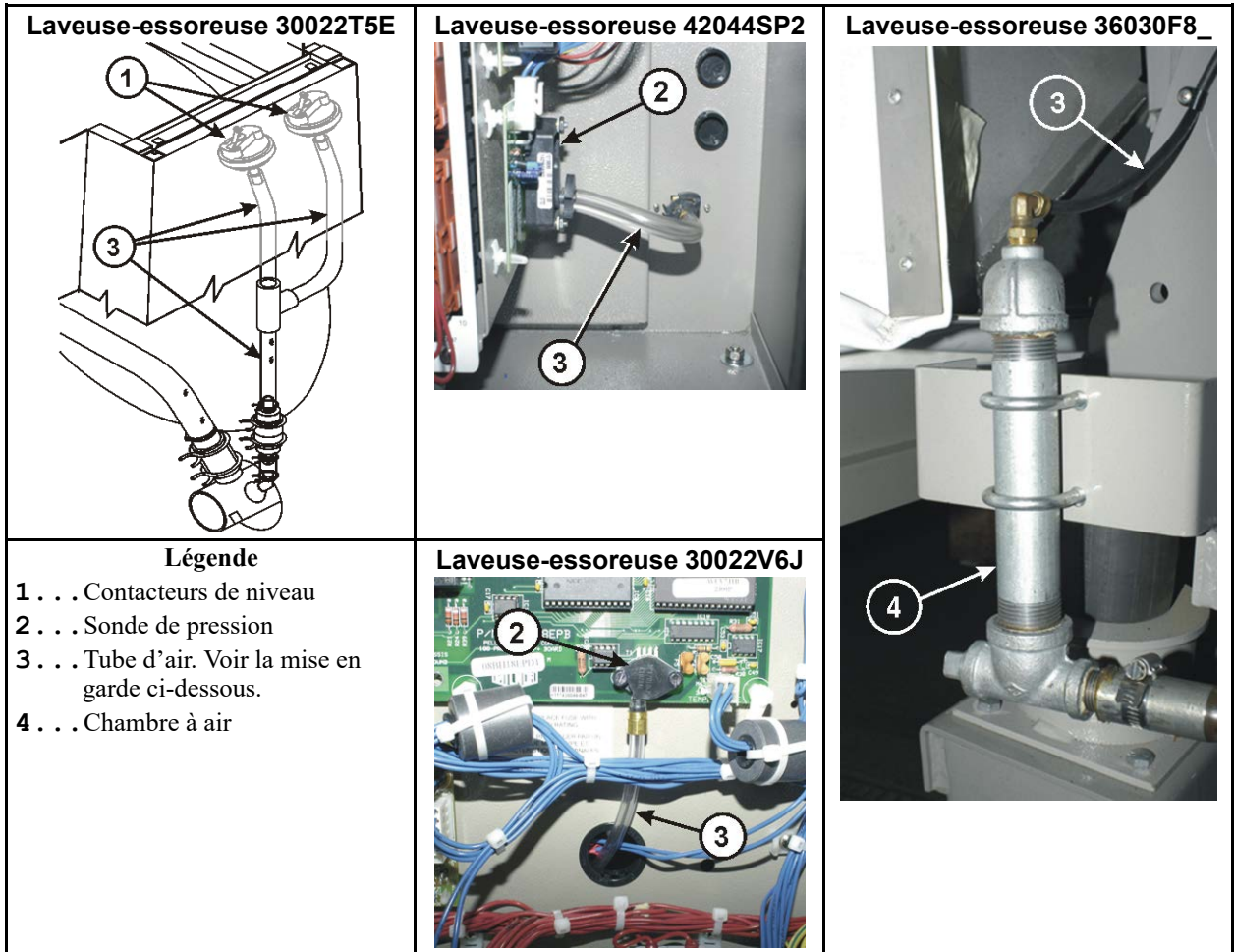
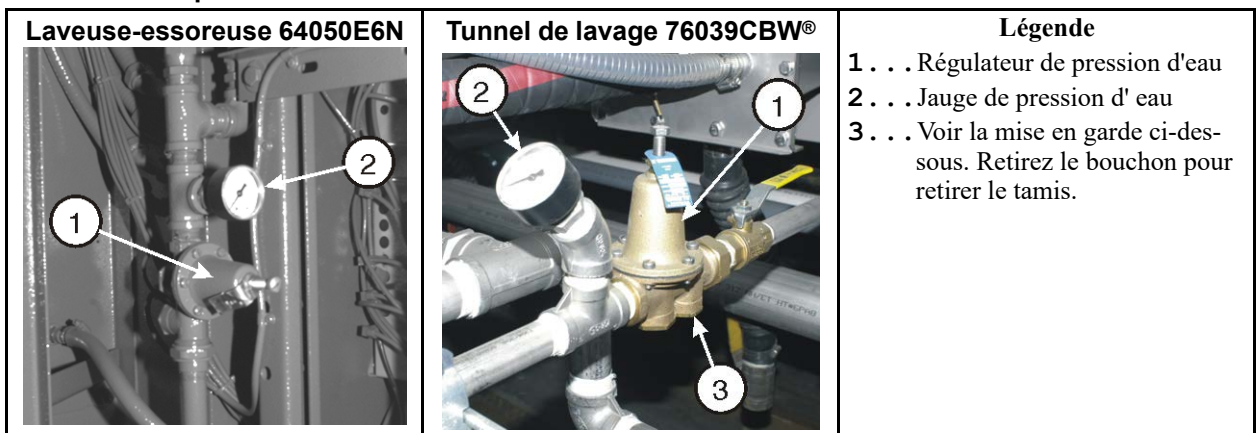

Figure 13. Régulateur de pression d'eau de rinçage des produits chimiques. Il s'agit d'exemples. Votre machine peut être différente.





**ATTENTION : une libération de vapeur sous pression** — peut provoquer de graves brûlures.

- ▶ Fermez la vanne d'arrêt externe et laissez évacuer la pression résiduelle avant de procéder à la maintenance.

Figure 14. Tamis d'entrée de vapeur. Il s'agit d'exemples. Votre machine peut être différente.

<p><b>Laveuse-essoreuse 42044SP2</b></p>	<p><b>Tunnel de lavage 76039CBW®</b></p>	<p><b>Légende</b></p> <p>1 . . . Tamis à vapeur. Éliminez la pression de vapeur avant de retirer le bouchon. Voir l'avertissement ci-dessous.</p> <p>2 . . . Le robinet de vapeur peut brûler</p>
--	--	---

### 3.2.5 Examen des mécanismes à air comprimé

BNWUUH01.C04 0000582435 A.2 B.2 G.2 8/30/23, 2:31 PM Released



**ATTENTION : La pression de l'air comprimé** — peut expulser des composants.

- ▶ Fermez la vanne d'arrêt externe et laissez évacuer la pression résiduelle avant de procéder à la maintenance.

Figure 15. Tamis d'entrée d'air comprimé. Il s'agit d'exemples. Votre machine peut être différente.

<p><b>Tamis en T. Cadre de machine extérieur sur certains modèles.</b></p>	<p><b>Tamis en T. Cadre de machine intérieur sur certains modèles.</b></p>	<p><b>Tamis en Y. Utilisé sur certains modèles</b></p>
<p><b>Légende</b></p> <p>1 . . . Voir la mise en garde ci-dessous. Retirez le bouchon pour retirer le tamis.</p> <p>2 . . . Entrée d'air comprimé.</p>		

**Figure 16. Filtre de conduite d'air à purge automatique servant à supprimer l'humidité et d'autres contaminations. Il s'agit d'exemples. Votre machine peut être différente.**

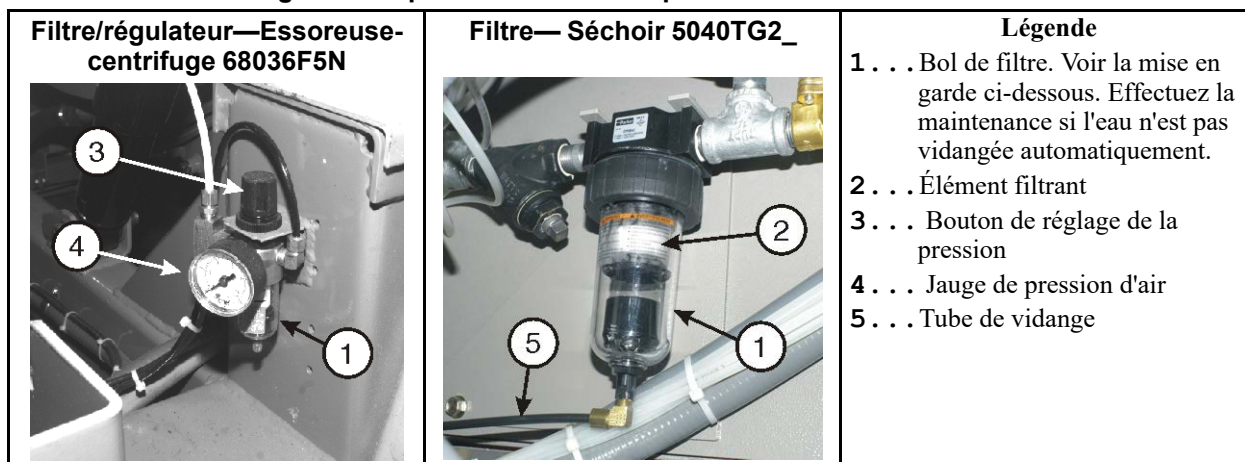





Votre machine est équipée d'un ou plusieurs mécanismes qui utilisent de l'air comprimé pour leurs mouvements. [Figure 17, page 38](#) présente quelques exemples. Pour examiner un mécanisme à air comprimé, regardez le mécanisme et écoutez-le fonctionner. **Ne touchez pas le mécanisme et ne placez pas la main dans la machine.** Vous pouvez généralement voir le mouvement directement sur un indicateur de position. Vous pouvez souvent entendre une vanne s'ouvrir et se fermer. Lorsque l'appareil de contrôle émet un signal pour actionner le mécanisme, la pression d'air doit augmenter suffisamment avant que le mouvement se produise. Lorsque le signal s'arrête, le système doit laisser évacuer l'air comprimé. Vous pouvez généralement entendre brièvement le bruit de l'air évacué.

Lorsqu'un mécanisme à air comprimé fonctionne correctement, son mouvement dure généralement moins de deux secondes. Ce mouvement est souple. Il n'y a pas de secousses, de changement de vitesse ni d'arrêt au milieu du déplacement. Un mécanisme qui ne fonctionne pas correctement entraîne des performances insuffisantes. Si le mécanisme ne fonctionne pas correctement et si vous ne pouvez pas remédier au problème, contactez votre revendeur ou Milnor®. Les causes possibles sont les suivantes :

- un blocage ou une fuite dans le tube d'air ;
- une vanne d'air pilote usée ;
- des composants usés dans le mécanisme ;
- une pression d'air insuffisante fournie à la machine ;
- un composant utilisé pour décontaminer la conduite d'air est colmaté ;
- une soupape d'échappement rapide ou un silencieux est colmaté ;
- sur les machines avec un lubrificateur de conduite d'air, un dysfonctionnement ou un mauvais réglage empêche une lubrification suffisante.

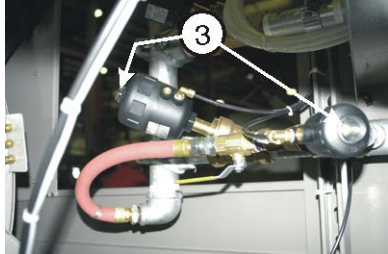
Figure 17. Mécanismes à air comprimé. Ce sont des exemples. Votre machine peut être différente.

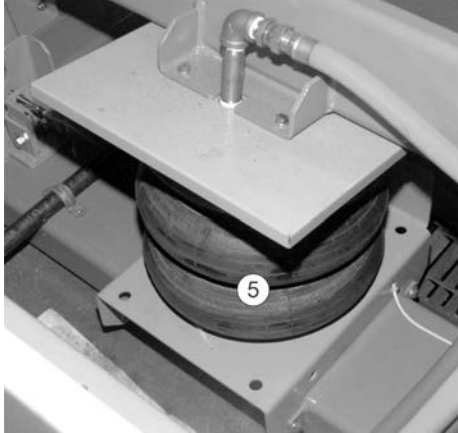
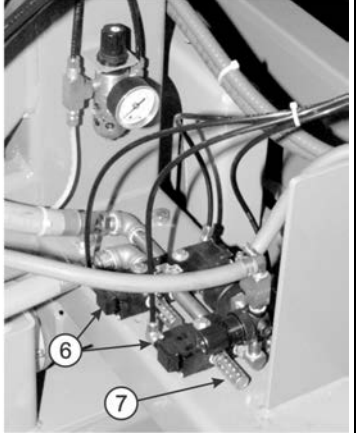
<p><b>Robinetts d'eau à actionnement pneumatique - Milnor® Type de vérin pneumatique</b></p>	<p><b>Robinetts de vidange à actionnement pneumatique - Milnor® Type de vérin pneumatique</b></p>	<p><b>Frein à bande à actionnement pneumatique - Milnor® Type à vérin pneumatique</b></p>
		
<p><b>Robinetts d'eau et de vapeur à actionnement pneumatique - Type en angle</b></p>	<p><b>Robinet d'eau à actionnement pneumatique - Type à robinet à boisseau sphérique</b></p>	<p><b>Légende</b></p>
		<p>1 . . . Robinets à pointeau réglés en usine pour actionner deux vérins pneumatiques ensemble. Ne réglez pas.</p> <p>2 . . . Soupapes d'échappement rapide</p> <p>3 . . . Indicateur de position. Jaune lorsque la soupape est ouverte.</p> <p>4 . . . Indicateur de position à flèche</p> <p>5 . . . Sac à air d'inclinaison</p> <p>6 . . . Vanne d'air</p> <p>7 . . . Silencieux</p>
<p><b>Composants à renversement pneumatique</b></p>		
		

### 3.2.6 Cellules photoélectriques et détecteurs de proximité

BNWUUH01.C11 0000582427 A.2 C.2 G.2 8/30/23, 2:31 PM Released

Figure 18. Capteur de vitesse (cellule photoélectrique) sur certaines machines

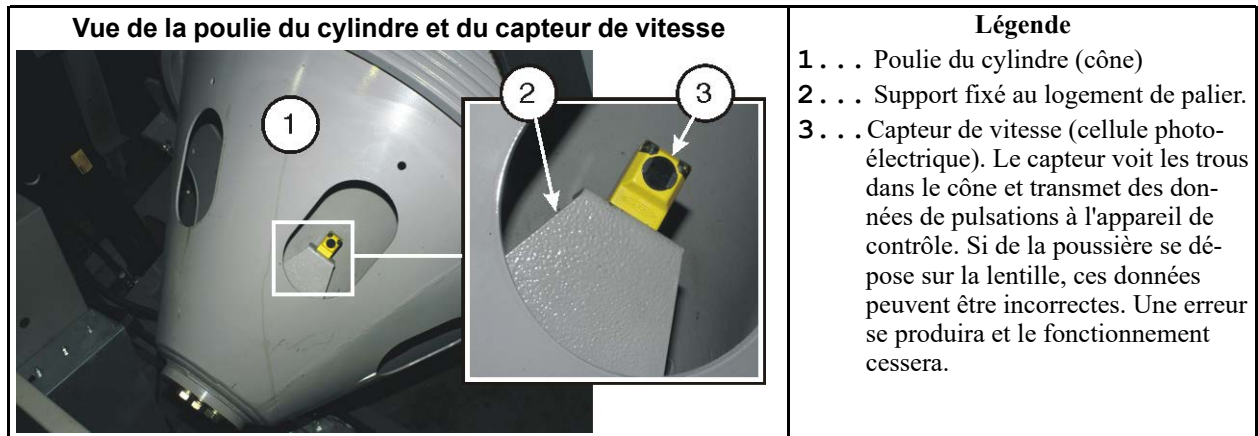
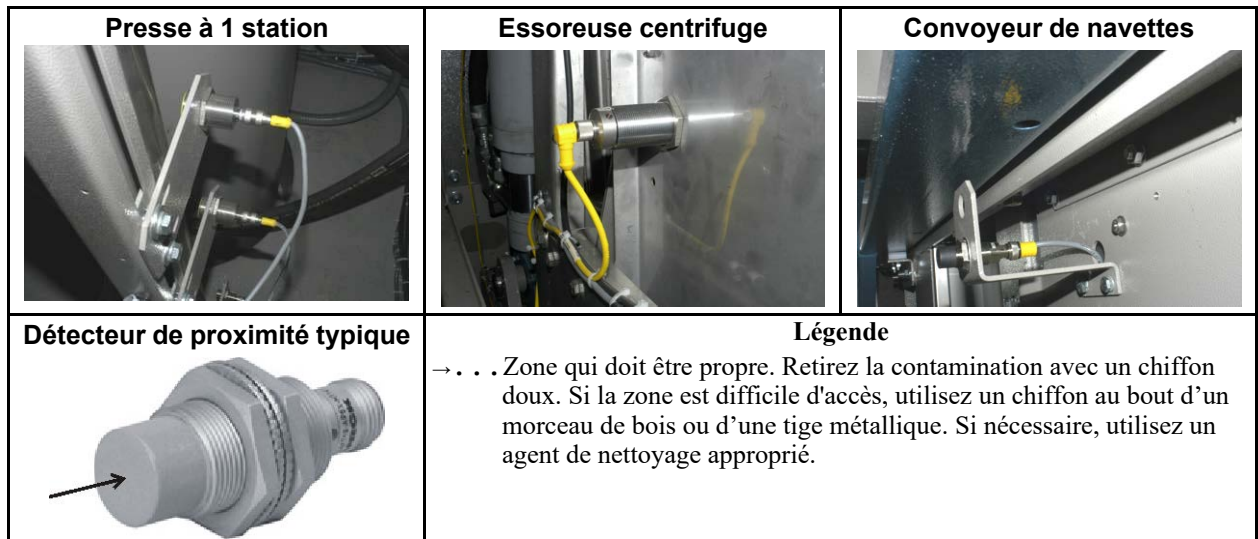

Figure 19. Détecteurs de proximité Ce sont des exemples. Votre machine peut être différente.



### 3.2.7 Comment effectuer un test des mécanismes d'arrêt d'urgence

BNWUUH01.C05 0000582486 A.2 G.2 8/30/23, 2:31 PM Released

Ce test est applicable aux machines équipées d'un ou plusieurs mécanismes d'arrêt en plus du bouton Arrêt (⓪). Réalisez ce test aux intervalles indiqués dans le résumé de l'entretien.

Définitions :

**circuit à 3 fils** Un circuit électrique en série sur une machine Milnor® qui doit se fermer avant que la machine puisse fonctionner. Si un commutateur du circuit s'ouvre, le mouvement de la machine s'arrête et l'alarme opérateur (un buzzer et un message affiché) est actionnée.

Lorsque vous appuyez sur le bouton de démarrage (①), le circuit à 3 fils se ferme, l'alarme opérateur s'arrête et la machine peut fonctionner.



**mécanismes d'arrêt d'urgence** Une commande manuelle qui ouvre le circuit à 3 fils lorsqu'une personne ou un objet actionne la commande. Exemples : bouton d'arrêt d'urgence, plaque de poussée, cordon de traction.

**bouton d'arrêt d'urgence** Un bouton-poussoir rouge sur un champ jaune qui se verrouille lorsqu'une personne le pousse (les contacts électriques restent ouverts). Il est nécessaire de faire tourner le bouton dans le sens des aiguilles d'une montre pour le déverrouiller. Une machine peut avoir ou non des boutons d'arrêt d'urgence.

**plaque de poussée** Une plaque métallique sur un convoyeur de navettes qui actionne un commutateur lorsqu'un objet applique une force suffisante sur la plaque. La plaque de poussée est généralement le premier composant de la navette qui heurte un objet sur le passage de la navette. Toutes les navettes Milnor® qui vont vers la gauche/droite sur un passage ont des plaques de poussée des deux côtés de la machine.



**AVERTISSEMENT :** — Vous pouvez être tué ou gravement blessé si une navette vous heurte, même si vous entrez d'abord en contact avec la plaque de poussée.

- ▶ Ne procédez jamais à un test de la plaque de poussée pendant le fonctionnement de la navette.

**cordon de traction** Un fil sur un convoyeur qui actionne un commutateur lorsqu'une personne tire sur ce fil. Tous les convoyeurs autonomes Milnor® (un convoyeur qui ne fait pas partie d'une plus grande machine) ont des cordons de traction des deux côtés du convoyeur.

Procédez à un test de tous les mécanismes d'arrêt d'urgence sur la machine de la manière suivante :

1. Mettez la machine sous tension (⚡).
2. Poussez le bouton de démarrage (①). **Ne faites pas fonctionner la machine.** Par exemple, ne lancez pas une formule et ne faites pas fonctionner la machine manuellement. Il n'est pas nécessaire de réaliser le test pendant le fonctionnement de la machine.
3. Actionnez un mécanisme d'arrêt d'urgence (exemples : bouton, plaque de poussée, cordon de traction). Si le mécanisme fonctionne correctement, l'alarme opérateur apparaît. Cela se produit-il ?
  - Oui—Libérez le mécanisme d'arrêt d'urgence si nécessaire. Par exemple, s'il s'agit d'un bouton d'arrêt d'urgence, faites tourner le bouton dans le sens des aiguilles d'une montre pour le déverrouiller. Poussez le bouton de démarrage (①). Réalisez le test sur un autre mécanisme d'arrêt d'urgence. Continuez jusqu'à ce que vous ayez réalisé le test sur tous les mécanismes d'arrêt d'urgence sur la machine.
  - Non—Un composant électrique est défectueux. Arrêtez la machine. Ne laissez pas la machine fonctionner avant d'avoir corrigé le problème.

BNWBUH01 / 2021514

BNWBUH01 0000582430 C.2 8/30/23, 2:31 PM Released

## 3.3 Composants de maintenance—Grandes essoreuses

BNWBUH01.C01 0000582414 A.2 B.2 C.2 8/30/23, 2:31 PM Released

### 3.3.1 Maintenance du lubrifiant pour les paliers d'entraînement remplis de graisse

BNWBUH01.C08 0000582490 A.2 C.2 8/30/23, 2:31 PM Released

Figure 20. Orifices de graissage pour assemblage de palier à graisse uniquement

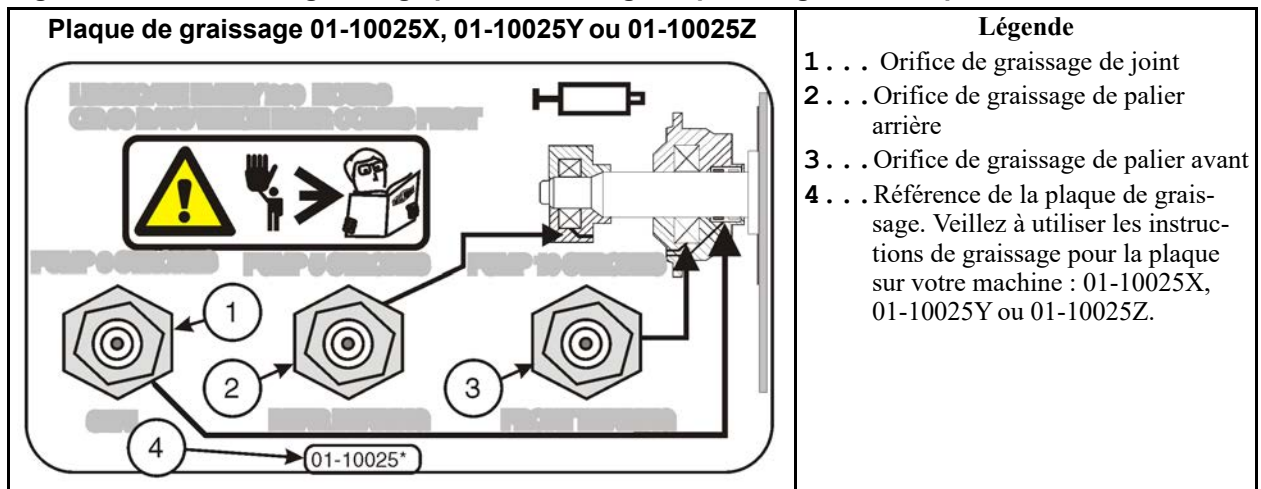

### 3.3.2 Maintenance du lubrifiant pour les composants qui ne font pas partie de la transmission

BNWBUH01.C09 0000582474 A.2 C.2 8/30/23, 2:31 PM Released

Figure 21. Orifices de graissage de porte—Modèles à poche ouverte. Il s'agit d'exemples. Votre machine peut être différente.



<p><b>Charnière de porte—modèles avec porte manuelle</b></p> 	<p><b>Tige de porte—modèles avec porte hydraulique</b></p> 	<p><b>Plongeur de verrou de porte—la plupart des modèles</b></p> 	<p><b>Plongeur d'ouverture de porte—certains modèles</b></p> 
<p><b>Légende</b></p> <p>1 . . . Orifice de graissage, une occurrence. Sur certaines machines, la porte doit être ouverte pour obtenir un accès.</p> <p>2 . . . Orifices de graissage, trois occurrences</p> <p>3 . . . Aucune lubrification nécessaire</p> <p>4 . . . Appliquez une fine couche de graisse à la surface du plongeur.</p>			

Figure 22. Autres éléments de la maintenance de routine de chaque côté des modèles de laveuse-essoreuse 48040F7\_

		<p><b>Légende</b></p> <p>1 . . . Orifices de graissage</p> <p>2 . . . pivot</p> <p>3 . . . butoirs d'inclinaison</p>
---	--	--

### 3.3.3 Comment effectuer un test du frein mécanique

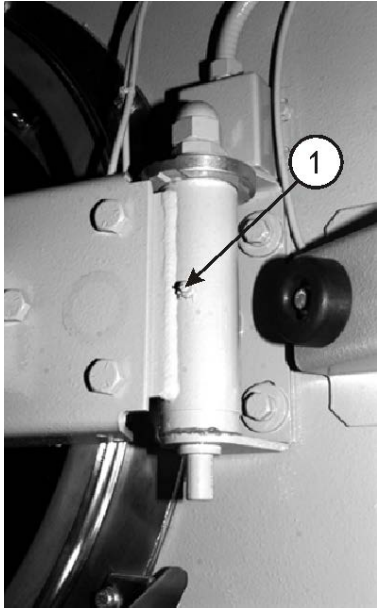
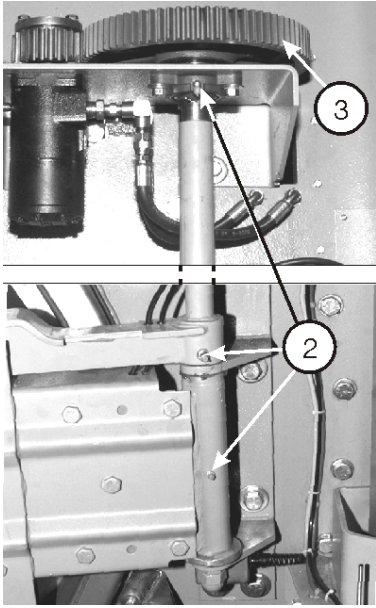
BNWBUH01.T01 0000582487 A.2 C.2 8/30/23, 2:31 PM Released

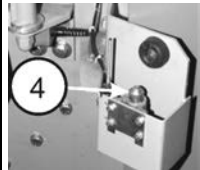
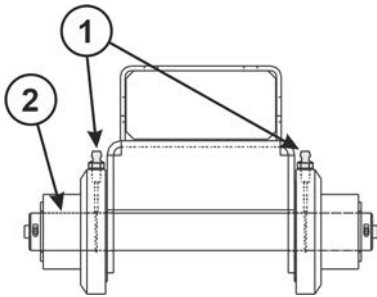
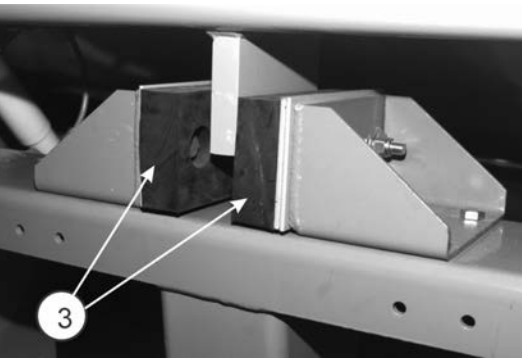

**AVERTISSEMENT :** L'actionnement d'un vérin et le linge — peuvent écraser ou casser des parties du corps lorsqu'une personne passe par la porte pour le chargement ou le déchargement.

- ▶ Ne laissez pas la machine fonctionner avec un frein mécanique défectueux.

Le frein à disque ou à bande retient le cylindre tandis que l'opérateur charge le linge dans la machine ou l'en décharge. Bien que, normalement, le frein mécanique n'arrête pas le cylindre pendant le fonctionnement (consulter la deuxième remarque ci-dessous pour en savoir plus), il peut le faire dans certaines situations inhabituelles. Par exemple, cela se produit si l'alimentation électrique est coupée ou si un bouton d'arrêt est actionné. Pour vous assurer que la machine fonctionne en toute sécurité, effectuez ce test aux intervalles indiqués dans le programme d'entretien :

1. Si la machine contient du linge, retirez-le.
2. Lancez une formule de lavage. Faites avancer la séquence jusqu'à une vidange (voir la première remarque ci-dessous). Vous devez faire le test lorsque le cylindre tourne à la vitesse de vidange. Une vitesse de lavage serait trop lente. Une vitesse d'extraction entraînerait une détérioration des composants de freinage, ce qui n'est pas nécessaire.
3. Observez le cylindre à travers la vitre de la porte ou de la jauge visuelle.
4. Poussez le commutateur d'arrêt d'urgence (⓪). Vérifiez que le cylindre s'arrête dans le temps prévu pour le type de machine :
  - Cylindre divisé et Staph Guard®—4 secondes.
  - Cylindre ouvert— 10 secondes



**REMARQUE :** Sur la plupart des machines, il n'y a pas de sortie manuelle pour la vitesse de vidange. Si votre machine possède une sortie de vitesse de vidange en **mode manuel**, utilisez-la à la place de la formule.

Si le cylindre ne s'arrête pas dans le temps prévu, des réparations sont nécessaires. Contactez votre revendeur ou Milnor®. Cela ne fait pas partie de l'entretien de routine.

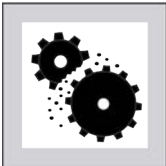

**ATTENTION :** Une utilisation inappropriée du frein mécanique pendant le fonctionnement automatique — entraîne une usure rapide des composants de freins.

- ▶ En cours de fonctionnement, laissez toujours le cylindre s'arrêter automatiquement.



**REMARQUE :** En fonctionnement automatique, le moteur de transmission, l'inverseur et les résistances de freinage arrêtent le cylindre. Si le cylindre ne s'arrête pas dans le laps de temps correct, un message d'erreur est généré. Si cette situation persiste, des réparations sont nécessaires. Contactez votre revendeur ou Milnor®. Cela ne fait pas partie de l'entretien de routine.

Figure 23. Exemple de frein à disque. Votre machine peut être différente.

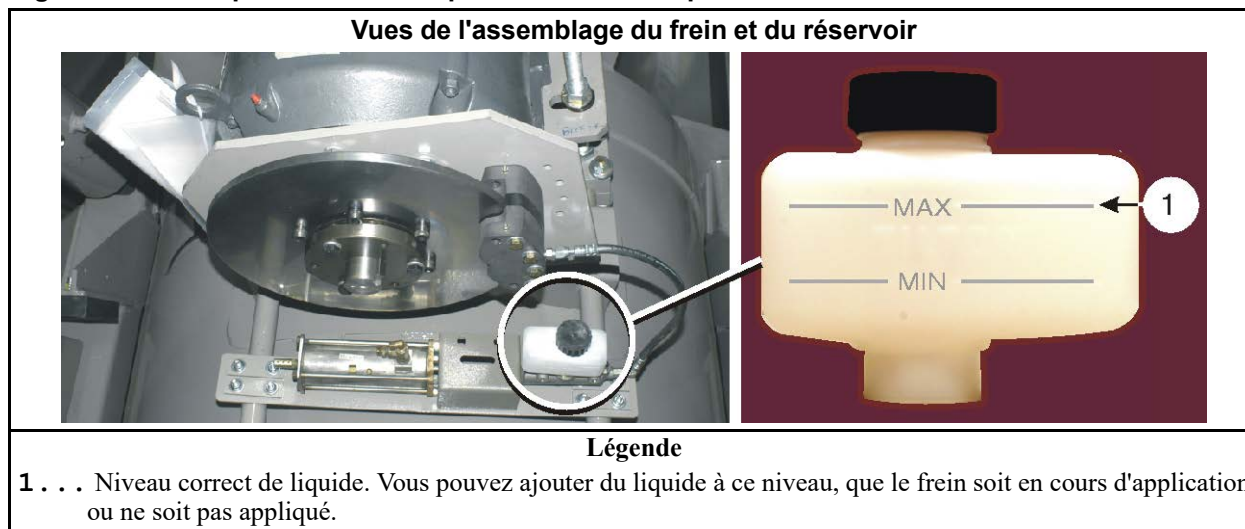

### 3.3.4 À propos des amortisseurs

BNWBUH01.C04 0000582461 A.2 C.2 8/30/23, 2:31 PM Released

Milnor® les laveuses-essoreuses avec une suspension à ressort en caoutchouc ont également des amortisseurs. Le type de raccord des amortisseurs est différent de celui des voitures. Il n'est pas nécessaire de remplacer les amortisseurs à des intervalles définis. Il faut simplement les remplacer en cas de signe de dommage ou de forte usure.

Examinez les amortisseurs aux intervalles indiqués dans le résumé de l'entretien. Un amortisseur doit être remplacé si vous voyez de l'huile sortir du mécanisme (voir la figure suivante). Cela indique que les joints sont usés. Il est également nécessaire de remplacer l'amortisseur si le caoutchouc dans le raccord est usé ou absent.

De mauvais amortisseurs laissent trop bouger l'enveloppe pendant le fonctionnement de la machine. En cas de mouvement brusque de cause incertaine, vous pouvez tester les amortisseurs de la manière suivante :

1. Retirez l'amortisseur de la machine.
2. Utilisez votre poids pour comprimer la longueur de l'amortisseur contre une surface dure. Un amortisseur exploitable se comprime lentement. Il revient également lentement à sa longueur initiale lorsque vous le relâchez. S'il se comprime ou s'étend rapidement, l'amortisseur est défectueux.

**Figure 24. Composants de la suspension de chaque côté de la laveuse-essoreuse reposant sur ressorts en caoutchouc (voir [Section 3.3.4 : À propos des amortisseurs, page 44](#))**

