

REAR VIEW

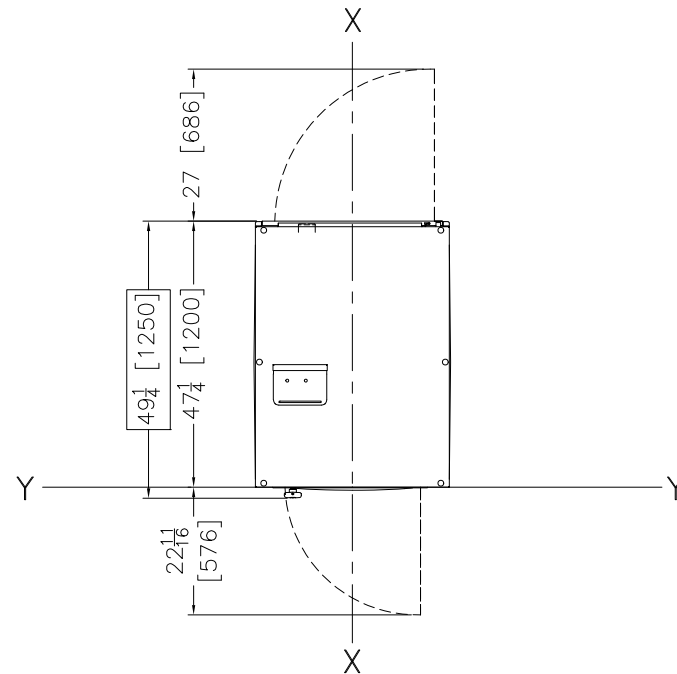

PLAN VIEW

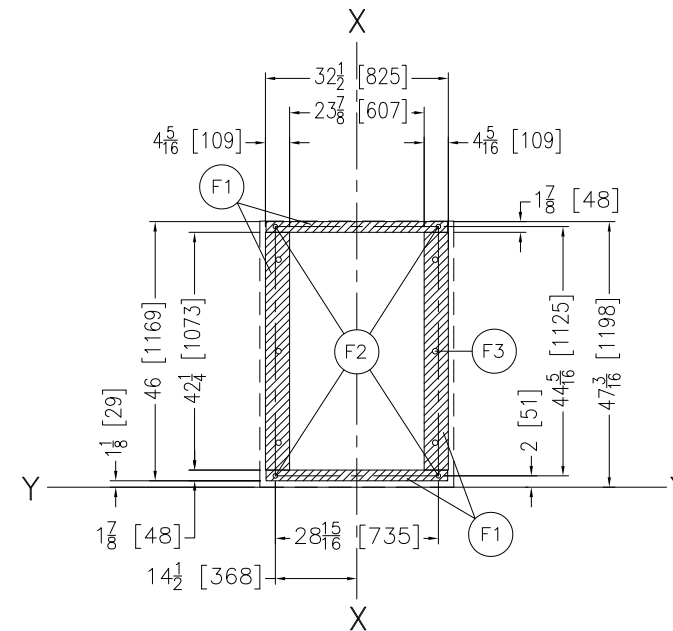

FOUNDATION PLAN VIEW

W3	HOT WATER FOR FLUSHING SUPPLY, 3/4" NPT CONNECTION, PRESSURE REGULATOR ASSEMBLY, REMOVED FOR SHIPPING, MUST BE ADDED AT INSTALLATION.
W2	COLD WATER INLET, 3/4" GARDEN HOSE, MALE THREAD CONNECTION. SEE NOTE 12.
W1	HOT WATER INLET, 3/4" GARDEN HOSE, MALE THREAD CONNECTION. SEE NOTE 12.
S1	OPTIONAL AIR-OPERATED STEAM INLET 1/2"NPT. CUSTOMER MUST SUPPLY A Y-STRAINER TO THIS INLET.
L2	PERISTALTIC CHEMICAL INLETS (5 PORTS) 3/8" NPT
L1	STANDARD SOAP CHUTE
F3	(6) 1" DIAMETER GROUT HOLES
F2	(4) 13/16" DIAMETER ANCHOR BOLT HOLES, USE 5/8" X 6" BOLTS MINIMUM.
F1	BASEPADS, SEE NOTE 8.
E3	MICROPROCESSOR CONTROL BOX
E2	E-P Plus Controller - MWF18J8 MODELS,
E1	MAIN ELECTRICAL CONNECTION
D1	DRAIN TO REAR, ELECTRIC, 3" PIPE SOCKET JOINT.

ITEM LEGEND

NOTES

- THIS MACHINE USES 1/2" WATER VALVES WITH 3/4" GARDEN HOSE CONNECTIONS. ADAPTERS ARE PROVIDED WITH 3/4" GARDEN HOSE, MALE THREAD, TO 1/2" FEMALE THREAD.
- 12[305] MINIMUM CLEARANCE IS RECOMMENDED FOR SERVICE TO MACHINE ON SIDES NOT REQUIRING OPERATOR ACCESS. 16[406] MINIMUM IS RECOMMENDED FOR OPERATOR ACCESS TO SOAP SUPPLY. SEE LOCAL ELECTRIC CODES FOR REQUIRED CLEARANCES.
- SHIM TO LEVEL THE MACHINE AND ALLOW FOR 1" [25] MINIMUM GROUT. ANCHOR ALL LABELED ANCHOR BOLT HOLES. USE 5/8" X 6" BOLTS, MINIMUM. SEE INSTALLATION MAINTENANCE MANUAL FOR FURTHER INSTRUCTIONS.
- SHADED AREA DENOTES BASE PADS WHICH MUST BE CONTINUOUSLY SUPPORT.
- DO NOT PRE-PIPE ANY CLOSER THAN 60 [1524].
- AS OF THIS WRITING, THE MINIMUM CLEARANCE REQUIRED BY U.S. NATIONAL ELECTRIC CODES, FROM ELECTRIC BOX TO ANY OBJECT IS:
 36 [914] IF OBJECT IS AN UNGROUNDED (INSULATED) WALL
 42 [1067] IF OBJECT IS A GROUNDED WALL (ie. BARE CONCRETE, BRICK, ETC.)
 48 [1219] IF OBJECT IS ANY LIVE PART.
 CHECK LOCAL ELECTRIC CODES FOR FURTHER RESTRICTIONS.
- CUSTOMER TO SUPPLY CIRCUIT BREAKER OR FUSED BRANCH CIRCUIT DISCONNECT (SAFETY) SWITCHES WITH LAG TYPE FUSES FROM POWER SOURCE TO MACHINE. A SEPARATE GROUND WIRE MUST BE CONNECTED FROM DISCONNECT TO EQUIPMENT.
- BASELINE "Z" IS THE REFERENCE FOR ALL VERTICAL DIMENSIONS. ON MACHINES WITH FIXED BASE PADS, BASELINE "Z" CORRESPONDS TO THE BOTTOM OF THE BASE PAD. ON MACHINES WITH ADJUSTABLE FEET, BASELINE "Z" CORRESPONDS TO THE BOTTOM OF THE FEET WHEN ADJUSTED SO THAT THE MACHINE IS AT ITS MINIMUM ACCEPTABLE HEIGHT. ON TRAVELING SHUTTLES, BASELINE "Z" CORRESPONDS TO THE BOTTOM OF THE BOTTOM RAIL. THE DISTANCE BETWEEN BASELINE "Z" AND THE FINISHED FLOOR WILL VARY AS REQUIRED TO ENSURE BASELINE "Z" IS HORIZONTAL AND ANY INTERFACING MACHINES REQUIRING GROUT ARE SET ON A MINIMUM 1[25] THICK GROUT BED.
- USE REFERENCE LINES "X", "Y", AND "Z" TO LOCATE ALL SERVICE CONNECTIONS.
- NUMBERS IN BRACKETS [] DENOTE DIMENSIONS IN MILLIMETERS.
- ALL DIMENSIONS SHOWN ARE APPROXIMATE, SUBJECT TO NORMAL MANUFACTURING TOLERANCES, AND TO OCCASIONAL CHANGES WITHOUT NOTICE THROUGH REDESIGN AND/OR RELOCATION OF COMPONENTS, ETC. DO NOT USE FOR CONSTRUCTION UNLESS CERTIFIED, AND IN NO EVENT PRE-PIPE CLOSER THAN FIVE FEET FROM MACHINE. FACTORY MUST BE CONSULTED FOR DIMENSIONS IF MACHINE IS TO BE MOVED THROUGH NARROW OR LOW CORRIDORS OR OPENINGS.

ATTENTION
 MOST REGULATORY AUTHORITIES (INCLUDING OSHA IN THE USA) HOLD THE OWNER/USER ULTIMATELY RESPONSIBLE TO MAINTAIN A SAFE WORKING ENVIRONMENT. ACCORDINGLY, THE OWNER/USER MUST RECOGNIZE ALL FORESEEABLE SAFETY HAZARDS, FURNISH SAFETY INSTRUCTIONS AND GUIDANCE TO ALL PERSONNEL WHO MAY COME IN CONTACT WITH THE INSTALLATION, AND PROVIDE ALL NECESSARY ADDITIONAL SAFETY GUARDS, FENCES, RESTRAINTS, DEVICES, ETC., NOT FURNISHED BY THE EQUIPMENT MANUFACTURER OR VENDOR.

ATTENTION
 THE FLOOR AND/OR OTHER SUPPORT COMPONENTS MUST HAVE SUFFICIENT STRENGTH (AND RIGIDITY WITH DUE CONSIDERATION FOR NATURAL OR RESONANT FREQUENCY THEREOF) TO WITHSTAND THE FULLY LOADED WEIGHT OF THE MACHINE INCLUDING THE GOODS, THE WATER, AND ANY REPEATED SINUSOIDAL (ROTATING) FORCES GENERATED DURING ITS OPERATION. WRITE THE FACTORY FOR ADDITIONAL MACHINE DATA FOR USE BY A COMPETENT SOIL AND/OR STRUCTURAL ENGINEER.

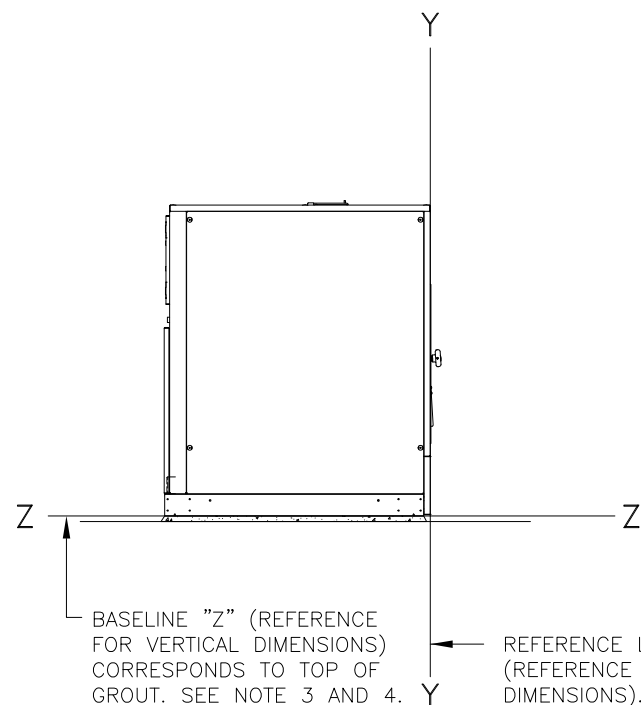

LEFT VIEW

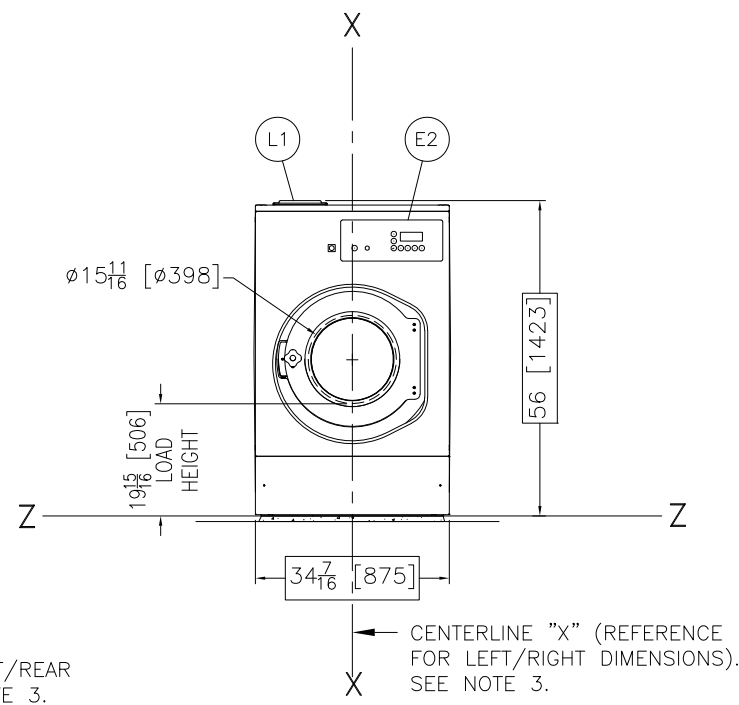

FRONT VIEW

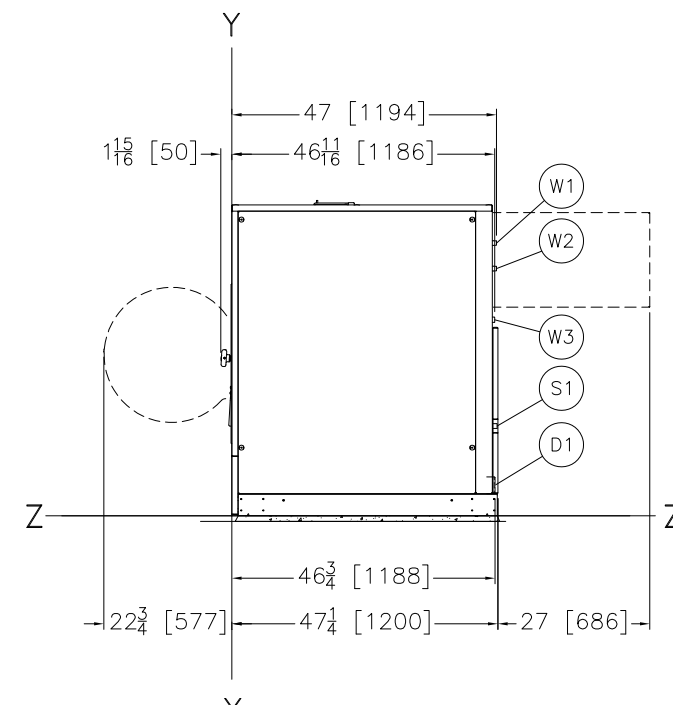

RIGHT VIEW

BASELINE "Z" (REFERENCE FOR VERTICAL DIMENSIONS) CORRESPONDS TO TOP OF GROUT. SEE NOTE 3 AND 4. Y REFERENCE LINE "Y" (REFERENCE FOR FRONT/REAR DIMENSIONS). SEE NOTE 3.

CENTERLINE "X" (REFERENCE FOR LEFT/RIGHT DIMENSIONS). SEE NOTE 3.

MWF18J8

MILNOR PELLERIN MILNOR CORPORATION
 P.O. Box 400 Kenner, LA 70063, USA, Phone 504/467-9591, FAX 504/468-3094, Email: milnorinfo@milnor.com