

FOUNDATION VIEW

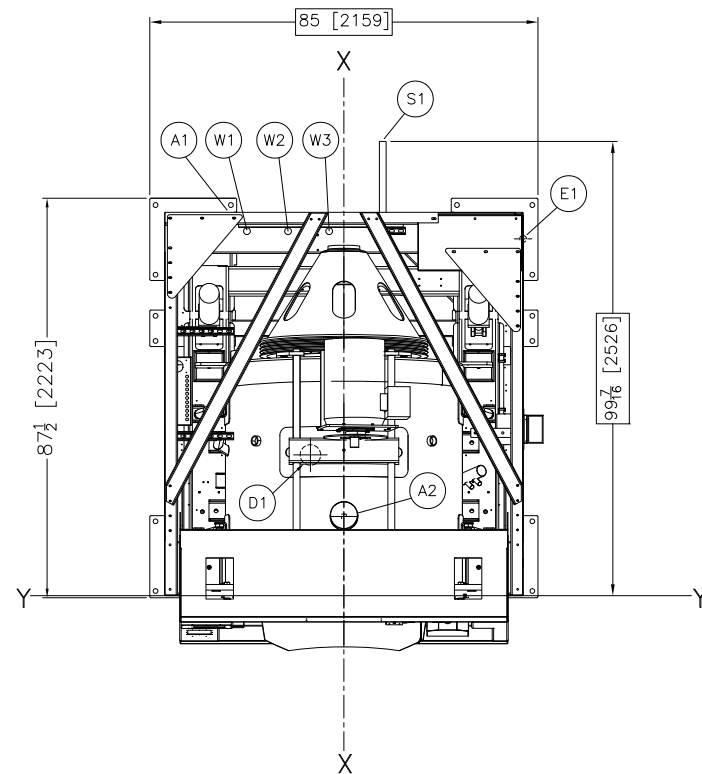

PLAN VIEW

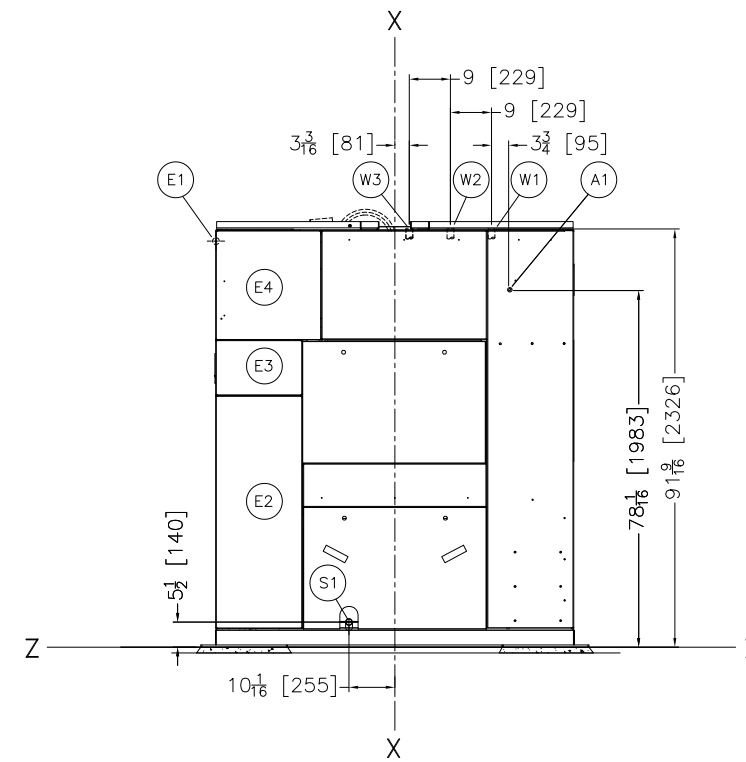

REAR VIEW

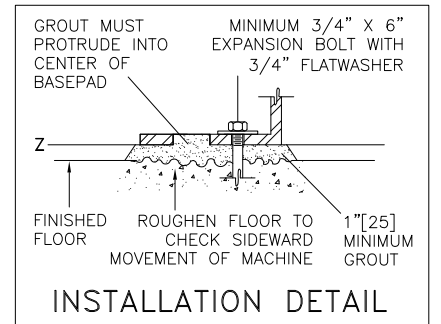

INSTALLATION DETAIL

W3	OPTIONAL REUSE WATER CONNECTION, 1-1/2" NPT
W2	COLD WATER CONNECTION, 1-1/2" NPT
W1	HOT WATER CONNECTION, 1-1/2" NPT
S1	STEAM INLET, 1-1/4" NPT
L1	16 PORT LIQUID SUPPLY INLETS
F3	GROUT HOLES
F2	(16) 1-1/16" DIAMETER ANCHOR BOLT HOLES, USE 3/4" X 6" BOLTS MINIMUM. (1) BOLT PER PAD MINIMUM.
F1	BASEPADS, SEE NOTE 8.
E4	INVERTER BOX
E3	MICROPROCESSOR CONTROL BOX
E2	MAIN ELECTRICAL CONTROL BOX
E1	MAIN ELECTRICAL CONNECTION
D2	DRAIN TROUGH
D1	DRAIN TO SUMP 4-1/2"[114] DIA. OUTLET
A2	VENT, 4" DIAMETER
A1	MAIN AIR CONNECTION, 1/4" NPT
ITEM	LEGEND

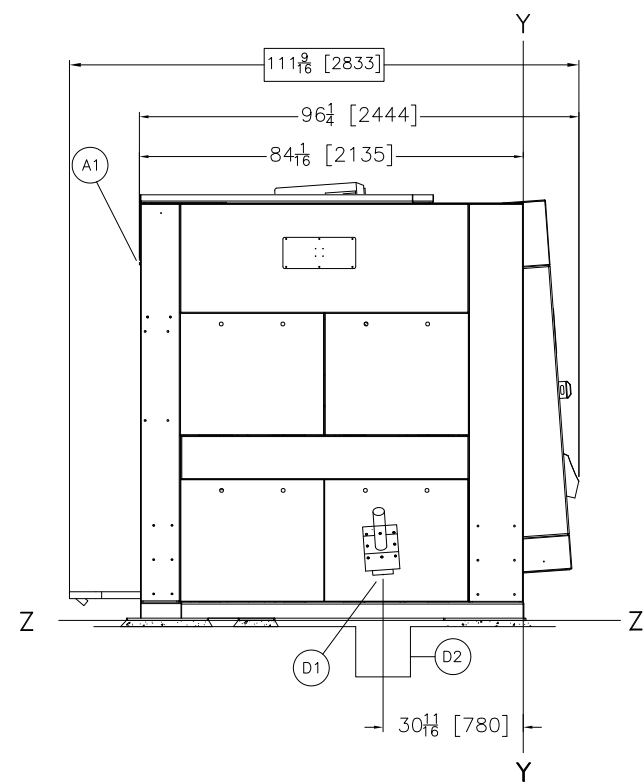

LEFT VIEW

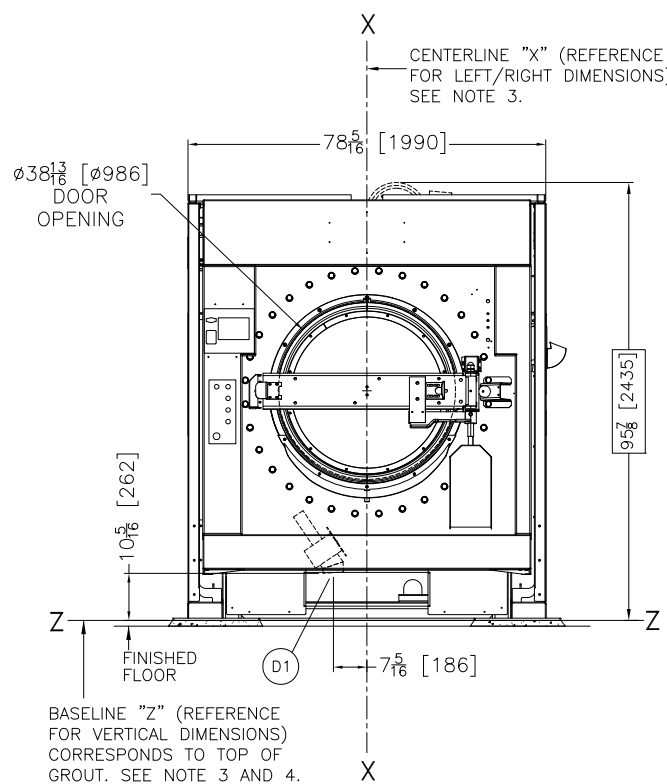

FRONT VIEW

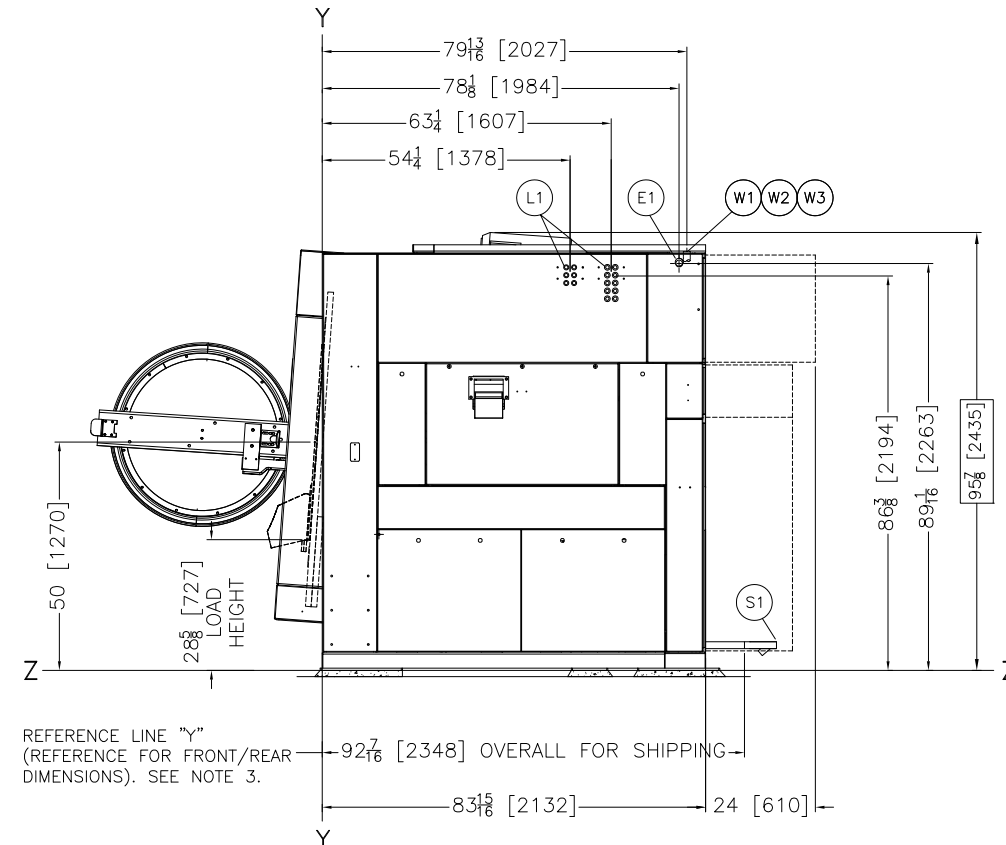

RIGHT VIEW

NOTES

- SHIM TO LEVEL THE MACHINE AND ALLOW FOR 1" [25] MINIMUM GROUT. ANCHOR WITH ONE ANCHOR BOLT PER PAD, MINIMUM. USE 3/4" X 6" BOLTS, MINIMUM. SEE INSTALLATION MAINTENANCE MANUAL FOR FURTHER INSTRUCTIONS.
- DRAIN VALVE MAY MOVE ± 1" [25] IN ANY DIRECTION DURING OPERATION AND MUST NOT BE RIGIDLY CONNECTED TO DRAIN.
- DUE TO VARYING WEIGHT OF MACHINE ON SPRINGS TOLERANCE IS ± 1/2 [13]. SEE DIMENSIONS WITH ASTERISK [*] ATTACHED.
- SHADED AREA DENOTES BASE PADS WHICH MUST BE CONTINUOUSLY SUPPORTED.
- DO NOT PRE-PIPE ANY CLOSER THAN 60 [1524].
- AS OF THIS WRITING, THE MINIMUM CLEARANCE REQUIRED BY U.S. NATIONAL ELECTRIC CODES, FROM ELECTRIC BOX TO ANY OBJECT IS:
 - 36 [914] IF OBJECT IS AN UNGROUNDED (INSULATED) WALL.
 - 42 [1067] IF OBJECT IS A GROUNDED WALL (ie. BARE CONCRETE, BRICK, ETC.).
 - 48 [1219] IF OBJECT IS ANY LIVE PART.
 CHECK LOCAL ELECTRIC CODES FOR FURTHER RESTRICTIONS.
- CUSTOMER TO SUPPLY CIRCUIT BREAKER OR FUSED BRANCH CIRCUIT DISCONNECT (SAFETY) SWITCHES WITH LAG TYPE FUSES FROM POWER SOURCE TO MACHINE. A SEPARATE GROUND WIRE MUST BE CONNECTED FROM DISCONNECT TO EQUIPMENT.
- BASELINE "Z" IS THE REFERENCE FOR ALL VERTICAL DIMENSIONS, ON MACHINES WITH FIXED BASE PADS, BASELINE "Z" CORRESPONDS TO THE BOTTOM OF THE BASE PAD. ON MACHINES WITH ADJUSTABLE FEET, BASELINE "Z" CORRESPONDS TO THE BOTTOM OF THE FEET WHEN ADJUSTED SO THAT THE MACHINE IS AT ITS MINIMUM ACCEPTABLE HEIGHT. ON TRAVELING SHUTTLES, BASELINE "Z" CORRESPONDS TO THE BOTTOM OF THE BOTTOM RAIL. THE DISTANCE BETWEEN BASELINE "Z" AND THE FINISHED FLOOR WILL VARY AS REQUIRED TO ENSURE BASELINE "Z" IS HORIZONTAL AND ANY INTERFACING MACHINES REQUIRING GROUT ARE SET ON A MINIMUM 1[25] THICK GROUT BED.
- USE REFERENCE LINES "X", "Y", AND "Z" TO LOCATE ALL SERVICE CONNECTIONS.
- NUMBERS IN BRACKETS [] DENOTE DIMENSIONS IN MILLIMETERS.
- ALL DIMENSIONS SHOWN ARE APPROXIMATE, SUBJECT TO NORMAL MANUFACTURING TOLERANCES, AND TO OCCASIONAL CHANGES WITHOUT NOTICE THROUGH REDESIGN AND/OR RELOCATION OF COMPONENTS, ETC. DO NOT USE FOR CONSTRUCTION UNLESS CERTIFIED, AND IN NO EVENT PRE-PIPE CLOSER THAN FIVE FEET FROM MACHINE. FACTORY MUST BE CONSULTED FOR DIMENSIONS IF MACHINE IS TO BE MOVED THROUGH NARROW OR LOW CORRIDORS OR OPENINGS.

ATTENTION
 MOST REGULATORY AUTHORITIES (INCLUDING OSHA IN THE USA) HOLD THE OWNER/USER ULTIMATELY RESPONSIBLE TO MAINTAIN A SAFE WORKING ENVIRONMENT. ACCORDINGLY, THE OWNER/USER MUST RECOGNIZE ALL FORESEEABLE SAFETY HAZARDS, FURNISH SAFETY INSTRUCTIONS AND GUIDANCE TO ALL PERSONNEL WHO MAY COME IN CONTACT WITH THE INSTALLATION, AND PROVIDE ALL NECESSARY ADDITIONAL SAFETY GUARDS, FENCES, RESTRAINTS, DEVICES, ETC., NOT FURNISHED BY THE EQUIPMENT MANUFACTURER OR VENDOR.

ATTENTION
 THE FLOOR AND/OR OTHER SUPPORT COMPONENTS MUST HAVE SUFFICIENT STRENGTH (AND RIGIDITY WITH DUE CONSIDERATION FOR NATURAL OR RESONANT FREQUENCY THEREOF) TO WITHSTAND THE FULLY LOADED WEIGHT OF THE MACHINE INCLUDING THE GOODS, THE WATER, AND ANY REPEATED SINUSOIDAL (ROTATING) FORCES GENERATED DURING ITS OPERATION. WRITE THE FACTORY FOR ADDITIONAL MACHINE DATA FOR USE BY A COMPETENT SOIL AND/OR STRUCTURAL ENGINEER.

4840H7R

DWG# BD4840H7RBE 2014112D
MILNOR PELLERIN MILNOR CORPORATION
 P.O. Box 400 Kenner, LA 70063, USA, Phone 504/467-9591, FAX 504/469-1849, Email: mktg@milnor.com