

W2	ELECTRIC COLD WATER INLET, 3/4" NPT
W1	ELECTRIC HOT WATER INLET, 3/4" NPT
N1	SEE NOTE 9.
L2	LIQUID SUPPLY INLETS
L1	STANDARD SOAP CHUTE
F2	(18) 13/16" DIAMETER ANCHOR BOLTS HOLES, USE 5/8" X 6" BOLTS MINIMUM.
F1	FOUNDATION BASE PADS, 2 PLACES.
E4	MILTOUCH CONTROLS™
E3	LOW VOLTAGE CONTROL BOX
E2	HIGH VOLTAGE CONTROL BOX
E1	MAIN ELECTRICAL CONNECTION
D1	DRAIN, 3" PIPE SOCKET JOINT
ITEM	LEGEND

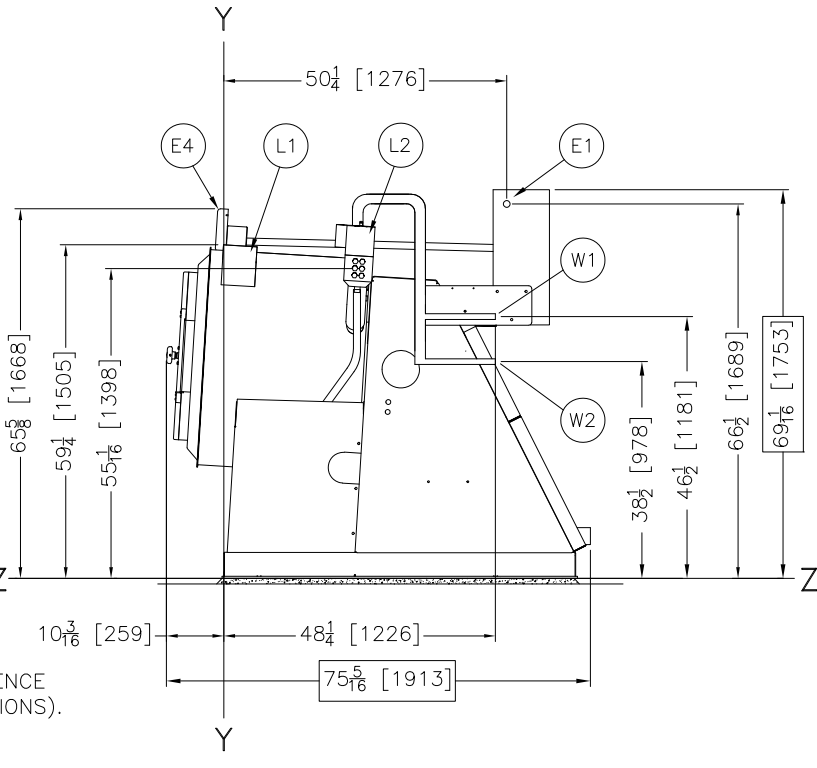
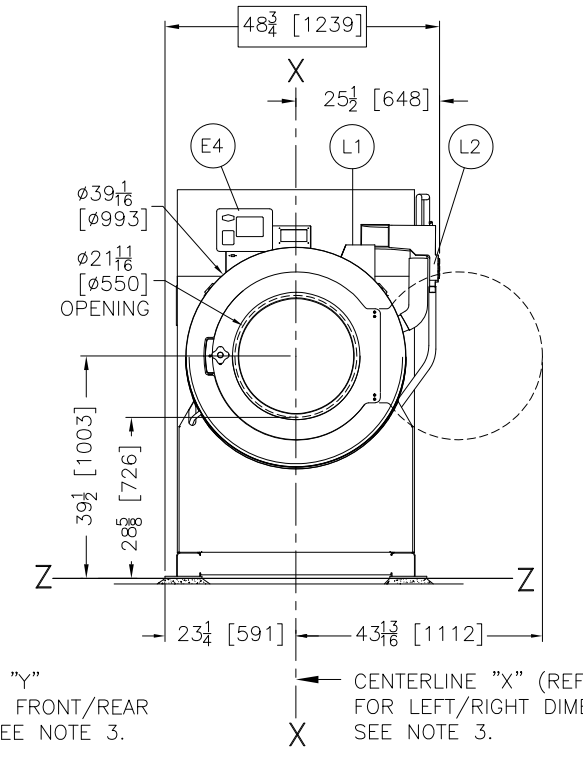
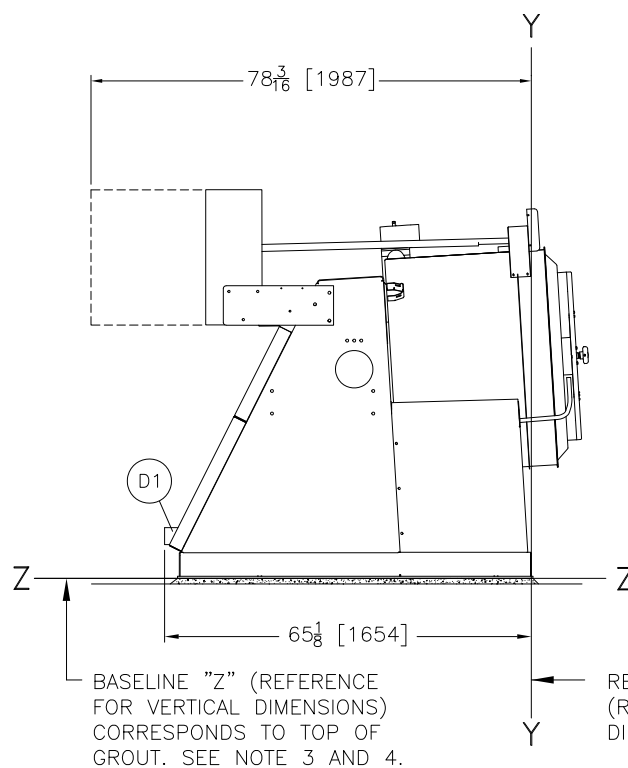

NOTES

- 11 SHIM TO LEVEL THE MACHINE AND ALLOW FOR 1" [25] MINIMUM GROUT. ANCHOR ALL (18) ANCHOR BOLT HOLES (SEE NOTE 9.) OR THE WARRANTY WILL BE DECLARED INVALID. USE 5/8" X 6" BOLTS, MINIMUM. SEE INSTALLATION MAINTENANCE MANUAL FOR FURTHER INSTRUCTIONS.
- 10 WATER INLET PIPING AND BRACKETRY CAN BE EASILY REMOVED TO TEMPORARILY REDUCE OVERALL MACHINE WIDTH FOR PASSAGE THROUGH DOORWAYS.
- 9 IF ABSOLUTELY NECESSARY, THE MACHINE MAY SPAN A DRAIN TROUGH UP TO 15" [381] WIDE (THUS ELIMINATING UP TO 2 ANCHOR BOLTS PER SIDE, BUT ONLY THOSE IDENTIFIED (N1)).
- 8 ENTIRE BASE OF MACHINE MUST BE CONTINUOUSLY SUPPORTED. IF MACHINE IS TO BE INSTALLED OVER A DRAIN TROUGH, THE MACHINE MUST BE MOUNTED TO A PEDESTAL BASE, NOT SUPPLIED BY P.M.C.
- 7 NEVER REDUCE DRAIN PIPING BELOW NPT SIZE OF CONNECTIONS.
- 6 AS OF THIS WRITING, THE MINIMUM CLEARANCE REQUIRED BY U.S. NATIONAL ELECTRIC CODES, FROM ELECTRIC BOX TO ANY OBJECT IS:
 36 [914] IF OBJECT IS AN UNGROUNDED (INSULATED) WALL.
 42 [1067] IF OBJECT IS A GROUNDED WALL (i.e. BARE CONCRETE, BRICK, ETC.)
 48 [1219] IF OBJECT IS ANY LIVE PART.
 CHECK LOCAL ELECTRIC CODES FOR FURTHER RESTRICTIONS.
- 5 CUSTOMER TO SUPPLY CIRCUIT BREAKER OR FUSED BRANCH CIRCUIT DISCONNECT (SAFETY) SWITCHES WITH LAG TYPE FUSES FROM POWER SOURCE TO MACHINE. A SEPARATE GROUND WIRE MUST BE CONNECTED FROM DISCONNECT TO EQUIPMENT.
- 4 BASELINE "Z" IS THE SAME FOR ALL MILNOR MACHINES AND IS SHOWN ON ALL DIMENSIONAL DRAWINGS. THE DISTANCE BETWEEN BASELINE "Z" AND THE FINISHED FLOOR MAY VARY (WITH CHANGES IN FLOOR HEIGHT) AS REQUIRED TO INSURE THAT BASELINE "Z" IS HORIZONTAL AND ALL COMPONENTS REQUIRING GROUT ARE SET ON A MINIMUM 1" [25] THICK GROUT BED.
- 3 USE REFERENCE LINES "X", "Y", AND "Z" TO LOCATE ALL SERVICE CONNECTIONS.
- 2 NUMBERS IN BRACKETS [] DENOTE DIMENSIONS IN MILLIMETERS.
- 1 ALL DIMENSIONS SHOWN ARE APPROXIMATE, SUBJECT TO NORMAL MANUFACTURING TOLERANCES, AND TO OCCASIONAL CHANGES WITHOUT NOTICE THROUGH REDESIGN AND/OR RELOCATION OF COMPONENTS, ETC. DO NOT USE FOR CONSTRUCTION UNLESS CERTIFIED, AND IN NO EVENT PRE-PIPE CLOSER THAN FIVE FEET FROM MACHINE. FACTORY MUST BE CONSULTED FOR DIMENSIONS IF MACHINE IS TO BE MOVED THROUGH NARROW OR LOW CORRIDORS OR OPENINGS.

ATTENTION

MOST REGULATORY AUTHORITIES (INCLUDING OSHA IN THE USA) HOLD THE OWNER/USER ULTIMATELY RESPONSIBLE TO MAINTAIN A SAFE WORKING ENVIRONMENT. ACCORDINGLY, THE OWNER/USER MUST RECOGNIZE ALL FORESEEABLE SAFETY HAZARDS, FURNISH SAFETY INSTRUCTIONS AND GUIDANCE TO ALL PERSONNEL WHO MAY COME IN CONTACT WITH THE INSTALLATION, AND PROVIDE ALL NECESSARY ADDITIONAL SAFETY GUARDS, FENCES, RESTRAINTS, DEVICES, ETC., NOT FURNISHED BY THE EQUIPMENT MANUFACTURER OR VENDOR.

ATTENTION

THE FLOOR AND/OR OTHER SUPPORT COMPONENTS MUST HAVE SUFFICIENT STRENGTH (AND RIGIDITY WITH DUE CONSIDERATION FOR NATURAL OR RESONANT FREQUENCY THEREOF) TO WITHSTAND THE FULLY LOADED WEIGHT OF THE MACHINE INCLUDING THE GOODS, THE WATER, AND ANY REPEATED SINUSOIDAL (ROTATING) FORCES GENERATED DURING ITS OPERATION. WRITE THE FACTORY FOR ADDITIONAL MACHINE DATA FOR USE BY A COMPETENT SOIL AND/OR STRUCTURAL ENGINEER.

BASELINE "Z" (REFERENCE FOR VERTICAL DIMENSIONS) CORRESPONDS TO TOP OF GROUT. SEE NOTE 3 AND 4.

REFERENCE LINE "Y" (REFERENCE FOR FRONT/REAR DIMENSIONS). SEE NOTE 3.

CENTERLINE "X" (REFERENCE FOR LEFT/RIGHT DIMENSIONS). SEE NOTE 3.

LEFT VIEW

FRONT VIEW

RIGHT VIEW

36026V7Z

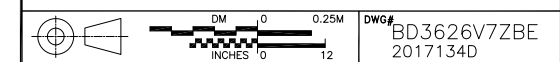

MILNOR PELLERIN MILNOR CORPORATION
 P.O. Box 400 Kenner, LA 70063, USA, Phone 504/467-9591,
 FAX 504/468-3094, Email: milnorinfo@milnor.com