

Published Manual Number/ECN: MAP30VXXBE/2011066A

- Publishing System: TPAS
- Access date: 2/4/2011
- Document ECN's: Latest Available



Service—

30015 and 30022Txx, Vxx Washer-Extractors



**Read the
separate
safety
manual
before
installing,
operating,
or servicing**



Please Read

About the Manual Identifying Information on the Cover—The front cover displays pertinent identifying information for this manual. Most important, are the published manual number (part number) /ECN (date code). Generally, when a replacement manual is furnished, it will have the same published manual number, but the latest available ECN. This provides the user with the latest information applicable to his machine. Similarly all documents comprising the manual will be the latest available as of the date the manual was printed, even though older ECN dates for those documents may be listed in the table of contents.

When communicating with the Milnor factory regarding this manual, please also provide the other identifying information shown on the cover, including the publishing system, access date, and whether the document ECN's are the latest available or exact.

Best Available Information—This manual contains the most accurate and complete information available when Milnor shipped your machine/software. Products are occasionally released with the best available documentation, even though the device identification (model numbers, etc.) on the documentation does not explicitly include the delivered model. In such cases, use the documentation provided.

Although unlikely, incorrect manuals may have been shipped with your machine. If you believe you received the wrong manuals, or if you need specific information about any aspect of your machine not addressed in the provided documentation, contact the Milnor Customer Service group.

References to Yellow Troubleshooting Pages—This manual may contain references to “yellow pages.” Although the pages containing trouble-shooting procedures are no longer printed on yellow paper, troubleshooting instructions, if any, will be contained in the easily located “Troubleshooting” section. See the table of contents.

Trademarks of Pellerin Milnor Corporation—The following terms, some of which may be used in this publication, are trademarks of Pellerin Milnor Corporation:

CBW [®]	E-P OneTouch [®]	Gear Guardian [®]	Mildata [®]	Milnor [®]	Staph-Guard [®]
E-P Express [®]	E-P Plus [®]	Mentor [®]	Milnet [®]	MultiTrac [™]	Visionex [™]

Trademarks of Other Companies—The following terms, some of which may be used in this publication, are trademarks of their respective companies:

Acronis [®]	Microsoft Windows 2000 [®]	Yaskawa [®]	Siemens [®]
Atlas 2000 [®]	Microsoft Office XP [®]	Microsoft Access [®]	Seagate Crystal Reports [®]
IBM [®]	Microsoft Windows NT [®]	Microsoft Windows XP [®]	

Comments and Suggestions

Help us to improve this manual by sending your comments to:

Pellerin Milnor Corporation
Attn: Technical Publications
P. O. Box 400
Kenner, LA 70063-0400
Fax: (504) 469-1849

Table of Contents

for MAP30VXXBE/2011066A

30015 and 30022Txx, Vxx Washer-Extractors

Page	Description	Document/ECN
1	Limited Standard Warranty	BMP720097/2008272A
2	How to Get the Necessary Repair Components	BIUUUD19/20081231
3	Safety—Rigid Washer Extractors	BIUUUS27RU/20051111
8	About the Forces Transmitted by Milnor® Washer-extractors	BIWUUI02/20001108
10	Understanding the Tag Guidelines	BIUUUI02RM/20110131
13	Avoiding Damage from Allied Remote Chemical Delivery Systems	BIWUUI03/20030306
18	Safety Placard Use and Placement 30015, 30022Txx & Vxx	BMP020103/2002145V
20	Safety Placard Use and Placement ISO 30015, 30022Txx & Vxx	BMP020104/2002145V
22	Guards and Covers 30015V7J,T5J,T5E 30022V6J,T5J,T5E	BMP000012/2001036V
25	Section 1: Service and Maintenance	
26	Preventive Maintenance	BIRQUM01AA/20050302
30	Fastener Torque Requirements	BIUUUM04/20080506
39	Section 2: Drive Assemblies	
40	Drive Chart 30015T5J,T5E & 30015T5J,T5E	BMP000006/2001036V
41	Drive Chart 30015V7J, 30022V6J	BMP000007/2000455V
42	Motor Mount - 30015, 30022, 36026, 42026, & 42030 Vxx, Txx	BMP000008/2010104B
45	Section 3: Bearing Assemblies	
46	Cylinder, Shell, Bearing, and Console Installation	BMP910037/2010353B
48	Main Bearing Assembly - 30015V7J, T5J, T5E	BMP910034/2010065B
50	Main Bearing Assembly - 30022V6J,T5E,T5X,C4E	BMP910033/2010065B
53	Section 4: Shell and Door Assemblies	
54	Shellfront Assembly, Conduit, & Interlock	BMP920024/2004055V
56	Door Assembly	BMP920009/2008232B
58	Interlock Assembly	BMP750046/2007513B
61	Section 5: Chemical Supply Devices	
62	Soap Chute Installation	BMP000040/2010482B
63	Peristaltic Supply Box	BMP000046/2009515B
65	3 Compartment Supply Injector	BMP770149/2000333V
67	Section 6: Water and Steam Piping and Assemblies	
68	Schematic Symbols Key	BMP920008/2000302V
69	Water/Steam/Drain Schematics - 30015V7J, T5E, T5X; 30022V6J, T5E, T5X	BMP000049/2011045B
71	Water Inlet Assemblies with Peristaltic Supply - 30015V7J & 30022V6J	BMP000047/2011045B

Table of Contents, cont.

Page	Description	Document/ECN
73	Water Inlet Assemblies with Peristaltic Supply - 30015 & 30022 T5E, T5X	BMP110009/2011045B
75	Level Switches - 30015V7J,T5J,T5E & 30022V6J,T5J,T5E	BMP000069/2010093B
77	1/2" & 3/4" Hayes Electric Steam Valves	BMP920028/2000302V
78	2-Way Electric Water Valve	BMP920029/98443V
80	Steam Inlet - 30015 & 30022 V6J	BMP110013/2011064B
82	Drain Sump Installation	BMP920014/2004055V
83	Drain Valve Installation	BMP920020/2001036V
85	3" Electric Drain Valve	BMP920017/2006214B
87	Section 7: Control and Sensing Assemblies	
88	Vibration Safety Switch Adjustments	MSSMA408BE/9273BV
90	Vibration Safety Switch	BMP910038/2007086B

PELLERIN MILNOR CORPORATION LIMITED STANDARD WARRANTY

We warrant to the original purchaser that MILNOR machines including electronic hardware/software (hereafter referred to as "equipment"), will be free from defects in material and workmanship for a period of one year from the date of shipment (unless the time period is specifically extended for certain parts pursuant to a specific MILNOR published extended warranty) from our factory with no operating hour limitation. This warranty is contingent upon the equipment being installed, operated and serviced as specified in the operating manual supplied with the equipment, and operated under normal conditions by competent operators.

Providing we receive written notification of a warranted defect within 30 days of its discovery, we will at our option repair or replace the defective part or parts, FOB our factory. We retain the right to require inspection of the parts claimed defective in our factory prior to repairing or replacing same. We will not be responsible, or in any way liable, for unauthorized repairs or service to our equipment, and this warranty shall be void if the equipment is tampered with, modified, or abused, used for purposes not intended in the design and construction of the machine, or is repaired or altered in any way without MILNOR's written consent.

Parts damaged by exposure to weather, to aggressive water, or to chemical attack are not covered by this warranty. For parts which require routine replacement due to normal wear such as gaskets, contact points, brake and clutch linings, belts, hoses, and similar parts the warranty time period is 90 days.

We reserve the right to make changes in the design and/or construction of our equipment (including purchased components) without obligation to change any equipment previously supplied.

ANY SALE OR FURNISHING OF ANY EQUIPMENT BY MILNOR IS MADE ONLY UPON THE EXPRESS UNDERSTANDING THAT MILNOR MAKES NO EXPRESSED OR IMPLIED WARRANTIES OF MERCHANTABILITY OR FITNESS FOR ANY PARTICULAR USE OR PURPOSE OR ANY OTHER WARRANTY IMPLIED BY LAW INCLUDING BUT NOT LIMITED TO REDHIBITION. MILNOR WILL NOT BE RESPONSIBLE FOR ANY COSTS OR DAMAGES ACTUALLY INCURRED OR REQUIRED AS A RESULT OF: THE FAILURE OF ANY OTHER PERSON OR ENTITY TO PERFORM ITS RESPONSIBILITIES, FIRE OR OTHER HAZARD, ACCIDENT, IMPROPER STORAGE, MIS-USE, NEGLIGENCE, POWER OR ENVIRONMENTAL CONTROL MALFUNCTIONS, DAMAGE FROM LIQUIDS, OR ANY OTHER CAUSE BEYOND THE NORMAL RANGE OF USE. REGARDLESS OF HOW CAUSED, IN NO EVENT SHALL MILNOR BE LIABLE FOR SPECIAL, INDIRECT, PUNITIVE, LIQUIDATED, OR CONSEQUENTIAL COSTS OR DAMAGES, OR ANY COSTS OR DAMAGES WHATSOEVER WHICH EXCEED THE PRICE PAID TO MILNOR FOR THE EQUIPMENT IT SELLS OR FURNISHES.

THE PROVISIONS ON THIS PAGE REPRESENT THE ONLY WARRANTY FROM MILNOR AND NO OTHER WARRANTY OR CONDITIONS, STATUTORY OR OTHERWISE, SHALL BE IMPLIED.

WE NEITHER ASSUME, NOR AUTHORIZE ANY EMPLOYEE OR OTHER PERSON TO ASSUME FOR US, ANY OTHER RESPONSIBILITY AND/OR LIABILITY IN CONNECTION WITH THE SALE OR FURNISHING OF OUR EQUIPMENT TO ANY BUYER.

How to Get the Necessary Repair Components



This document uses Simplified Technical English.
Learn more at <http://www.asd-ste100.org>.

You can get components to repair your machine from the approved supplier where you got this machine. Your supplier will usually have the necessary components in stock. You can also get components from the Milnor[®] factory.

Tell the supplier the machine model and serial number and this data for each necessary component:

- The component number from this manual
- The component name if known
- The necessary quantity
- The necessary transportation requirements
- If the component is an electrical component, give the schematic number if known.
- If the component is a motor or an electrical control, give the nameplate data from the used component.

To write to the Milnor factory:

Pellerin Milnor Corporation
Post Office Box 400
Kenner, LA 70063-0400
UNITED STATES

Telephone: 504-467-2787
Fax: 504-469-9777
Email: parts@milnor.com

— End of BIUUUD19 —

Safety—Rigid Washer Extractors

1. General Safety Requirements—Vital Information for Management Personnel [Document BIUUUS04]

Incorrect installation, neglected preventive maintenance, abuse, and/or improper repairs, or changes to the machine can cause unsafe operation and personal injuries, such as multiple fractures, amputations, or death. The owner or his selected representative (owner/user) is responsible for understanding and ensuring the proper operation and maintenance of the machine. The owner/user must familiarize himself with the contents of all machine instruction manuals. The owner/user should direct any questions about these instructions to a Milnor® dealer or the Milnor® Service department.

Most regulatory authorities (including OSHA in the USA and CE in Europe) hold the owner/user ultimately responsible for maintaining a safe working environment. Therefore, the owner/user must do or ensure the following:

- recognize all foreseeable safety hazards within his facility and take actions to protect his personnel, equipment, and facility;
- work equipment is suitable, properly adapted, can be used without risks to health or safety, and is adequately maintained;
- where specific hazards are likely to be involved, access to the equipment is restricted to those employees given the task of using it;
- only specifically designated workers carry out repairs, modifications, maintenance, or servicing;
- information, instruction, and training is provided;
- workers and/or their representatives are consulted.

Work equipment must comply with the requirements listed below. The owner/user must verify that installation and maintenance of equipment is performed in such a way as to support these requirements:

- control devices must be visible, identifiable, and marked; be located outside dangerous zones; and not give rise to a hazard due to unintentional operation;
- control systems must be safe and breakdown/damage must not result in danger;
- work equipment is to be stabilized;
- protection against rupture or disintegration of work equipment;
- guarding, to prevent access to danger zones or to stop movements of dangerous parts before the danger zones are reached. Guards to be robust; not give rise to any additional hazards; not be easily removed or rendered inoperative; situated at a sufficient distance from the danger zone; not restrict view of operating cycle; allow fitting, replacing, or maintenance by restricting access to relevant area and without removal of guard/protection device;
- suitable lighting for working and maintenance areas;
- maintenance to be possible when work equipment is shut down. If not possible, then protection measures to be carried out outside danger zones;
- work equipment must be appropriate for preventing the risk of fire or overheating; discharges of gas, dust, liquid, vapor, other substances; explosion of the equipment or substances in it.

- 1.1. **Laundry Facility**—Provide a supporting floor that is strong and rigid enough to support—with a reasonable safety factor and without undue or objectionable deflection—the weight of the fully loaded machine and the forces transmitted by it during operation. Provide sufficient clearance for machine movement. Provide any safety guards, fences, restraints, devices, and verbal and/or posted restrictions necessary to prevent personnel, machines, or other moving machinery from accessing the machine or its path. Provide adequate ventilation to carry away heat and vapors. Ensure service connections to installed machines meet local and national safety standards, especially regarding the electrical disconnect (see the National Electric Code). Prominently post safety information, including signs showing the source of electrical disconnect.
- 1.2. **Personnel**—Inform personnel about hazard avoidance and the importance of care and common sense. Provide personnel with the safety and operating instructions that apply to them. Verify that personnel use proper safety and operating procedures. Verify that personnel understand and abide by the warnings on the machine and precautions in the instruction manuals.
- 1.3. **Safety Devices**—Ensure that no one eliminates or disables any safety device on the machine or in the facility. Do not allow machine to be used with any missing guard, cover, panel or door. Service any failing or malfunctioning device before operating the machine.
- 1.4. **Hazard Information**—Important information on hazards is provided on the machine safety placards, in the Safety Guide, and throughout the other machine manuals. **Placards must be kept clean so that the information is not obscured. They must be replaced immediately if lost or damaged. The Safety Guide and other machine manuals must be available at all times to the appropriate personnel.** See the machine service manual for safety placard part numbers. Contact the Milnor Parts department for replacement placards or manuals.
- 1.5. **Maintenance**—Ensure the machine is inspected and serviced in accordance with the norms of good practice and with the preventive maintenance schedule. Replace belts, pulleys, brake shoes/disks, clutch plates/tires, rollers, seals, alignment guides, etc. before they are severely worn. Immediately investigate any evidence of impending failure and make needed repairs (e.g., cylinder, shell, or frame cracks; drive components such as motors, gear boxes, bearings, etc., whining, grinding, smoking, or becoming abnormally hot; bending or cracking of cylinder, shell, frame, etc.; leaking seals, hoses, valves, etc.) Do not permit service or maintenance by unqualified personnel.

2. **Safety Alert Messages—Internal Electrical and Mechanical Hazards** [Document BIUUUS11]

The following are instructions about hazards inside the machine and in electrical enclosures.



WARNING 1: Electrocution and Electrical Burn Hazards—Contact with electric power can kill or seriously injure you. Electric power is present inside the cabinetry unless the main machine power disconnect is off.

- Do not unlock or open electric box doors.
- Do not remove guards, covers, or panels.
- Do not reach into the machine housing or frame.
- Keep yourself and others off of machine.
- Know the location of the main machine disconnect and use it in an emergency to remove all electric power from the machine.



WARNING 2: Entangle and Crush Hazards—Contact with moving components normally isolated by guards, covers, and panels, can entangle and crush your limbs. These components move automatically.

- Do not remove guards, covers, or panels.
- Do not reach into the machine housing or frame.
- Keep yourself and others off of machine.
- Know the location of all emergency stop switches, pull cords, and/or kick plates and use them in an emergency to stop machine motion.

3. Safety Alert Messages—Cylinder and Processing Hazards

[Document BIUUUS13]

The following are instructions about hazards related to the cylinder and laundering process.



DANGER 3: Entangle and Sever Hazards—Contact with goods being processed can cause the goods to wrap around your body or limbs and dismember you. The goods are normally isolated by the locked cylinder door.

- Do not attempt to open the door or reach into the cylinder until the cylinder is stopped.
- Do not touch goods inside or hanging partially outside the turning cylinder.
- Do not operate the machine with a malfunctioning door interlock.
- Know the location of all emergency stop switches, pull cords, and/or kick plates and use them in an emergency to stop machine motion.
- Know the location of the main machine disconnect and use it in an emergency to remove all electric power from the machine.



WARNING 4: Crush Hazards—Contact with the turning cylinder can crush your limbs. The cylinder will repel any object you try to stop it with, possibly causing the object to strike or stab you. The turning cylinder is normally isolated by the locked cylinder door.

- Do not attempt to open the door or reach into the cylinder until the cylinder is stopped.
- Do not place any object in the turning cylinder.
- Do not operate the machine with a malfunctioning door interlock.



WARNING 5: Confined Space Hazards—Confinement in the cylinder can kill or injure you. Hazards include but are not limited to panic, burns, poisoning, suffocation, heat prostration, biological contamination, electrocution, and crushing.

- Do not attempt unauthorized servicing, repairs, or modification.



WARNING 6: Explosion and Fire Hazards—Flammable substances can explode or ignite in the cylinder, drain trough, or sewer. The machine is designed for washing with water, not any other solvent. Processing can cause solvent-containing goods to give off flammable vapors.

- Do not use flammable solvents in processing.
- Do not process goods containing flammable substances. Consult with your local fire department/public safety office and all insurance providers.

4. Safety Alert Messages—Unsafe Conditions [Document BIUUUS14]

4.1. Damage and Malfunction Hazards

4.1.1. Hazards Resulting from Inoperative Safety Devices



DANGER 7: Entangle and Sever Hazards—Cylinder door interlock—Operating the machine with a malfunctioning door interlock can permit opening the door when the cylinder is turning and/or starting the cycle with the door open, exposing the turning cylinder.

- Do not operate the machine with any evidence of damage or malfunction.



WARNING 8: Multiple Hazards—Operating the machine with an inoperative safety device can kill or injure personnel, damage or destroy the machine, damage property, and/or void the warranty.

- Do not tamper with or disable any safety device or operate the machine with a malfunctioning safety device. Request authorized service.



WARNING 9: Electrocutation and Electrical Burn Hazards—Electric box doors—Operating the machine with any electric box door unlocked can expose high voltage conductors inside the box.

- Do not unlock or open electric box doors.



WARNING 10: Entangle and Crush Hazards—Guards, covers, and panels—Operating the machine with any guard, cover, or panel removed exposes moving components.

- Do not remove guards, covers, or panels.

4.1.2. Hazards Resulting from Damaged Mechanical Devices



WARNING 11: Multiple Hazards—Operating a damaged machine can kill or injure personnel, further damage or destroy the machine, damage property, and/or void the warranty.

- Do not operate a damaged or malfunctioning machine. Request authorized service.



WARNING 12: Explosion Hazards—Cylinder—A damaged cylinder can rip apart during extraction, puncturing the shell and discharging metal fragments at high speed.

- Do not operate the machine with any evidence of damage or malfunction.



WARNING 13: Explosion Hazards—Clutch and speed switch (multiple motor machines)—A damaged clutch or speed switch can permit the low speed motor to engage during extract. This will over-speed the motor and pulleys and can cause them to rip apart, discharging metal fragments at high speed.

- Stop the machine immediately if any of these conditions occur: • abnormal whining sound during extract • skidding sound as extract ends • clutches remain engaged or re-engage during extract

4.2. Careless Use Hazards

4.2.1. Careless Operation Hazards—Vital Information for Operator Personnel (see also operator hazards throughout manual)



WARNING 14: Multiple Hazards—Careless operator actions can kill or injure personnel, damage or destroy the machine, damage property, and/or void the warranty.

- Do not tamper with or disable any safety device or operate the machine with a malfunctioning safety device. Request authorized service.
- Do not operate a damaged or malfunctioning machine. Request authorized service.
- Do not attempt unauthorized servicing, repairs, or modification.
- Do not use the machine in any manner contrary to the factory instructions.
- Use the machine only for its customary and intended purpose.
- Understand the consequences of operating manually.

4.2.2. Careless Servicing Hazards—Vital Information for Service Personnel (see also service hazards throughout manuals)



WARNING 15: Electrocutation and Electrical Burn Hazards—Contact with electric power can kill or seriously injure you. Electric power is present inside the cabinetry unless the main machine power disconnect is off.

- Do not service the machine unless qualified and authorized. You must clearly understand the hazards and how to avoid them.
- Abide by the current OSHA lockout/tagout standard when lockout/tagout is called for in the service instructions. Outside the USA, abide by the OSHA standard in the absence of any other overriding standard.



WARNING 16: Entangle and Crush Hazards—Contact with moving components normally isolated by guards, covers, and panels, can entangle and crush your limbs. These components move automatically.

- Do not service the machine unless qualified and authorized. You must clearly understand the hazards and how to avoid them.
- Abide by the current OSHA lockout/tagout standard when lockout/tagout is called for in the service instructions. Outside the USA, abide by the OSHA standard in the absence of any other overriding standard.



WARNING 17: Confined Space Hazards—Confinement in the cylinder can kill or injure you. Hazards include but are not limited to panic, burns, poisoning, suffocation, heat prostration, biological contamination, electrocution, and crushing.

- Do not enter the cylinder until it has been thoroughly purged, flushed, drained, cooled, and immobilized.

— End of BIUUUS27 —

About the Forces Transmitted by Milnor® Washer-extractors

During washing and extracting, all washer-extractors transmit both static and dynamic (cyclic) forces to the floor, foundation, or any other supporting structure. During washing, the impact of the goods as they drop imparts forces which are quite difficult to quantify. Size for size, both rigid and flexibly-mounted machines transmit approximately the same forces during washing. During extracting, rigid machines transmit forces up to 30 times greater than equivalent flexibly-mounted models. The actual magnitude of these forces vary according to several factors:

- machine size,
- final extraction speed,
- amount, condition, and type of goods being processed,
- the liquor level and chemical conditions in the bath preceding extraction, and
- other miscellaneous factors.

Estimates of the maximum force normally encountered are available for each Milnor® model and size upon request. Floor or foundation sizes shown on any Milnor® document are only for on-grade situations based only on previous experience without implying any warranty, obligation, or responsibility on our part.

1. Rigid Machines

Size for size, rigid washer-extractors naturally require a stronger, more rigid floor, foundation, or other supporting structure than flexibly-mounted models. If the supporting soil under the slab is itself strong and rigid enough and has not subsided to leave the floor slab suspended without support, on grade installations can often be made directly to an existing floor slab if it has enough strength and rigidity to safely withstand our published forces without transmitting undue vibration. If the subsoil has subsided, or if the floor slab itself has insufficient strength and rigidity, a deeper foundation, poured as to become monolithic with the floor slab, may be required. Support pilings may even be required if the subsoil itself is “springy” (i.e., if its resonant frequency is near the operating speed of the machine). Above-grade installations of rigid machines also require a sufficiently strong and rigid floor or other supporting structure as described below.

2. Flexibly-mounted Machines

Size for size, flexibly-mounted machines generally do not require as strong a floor, foundation, or other supporting structure as do rigid machines. However, a floor or other supporting structure having sufficient strength and rigidity, as described in [Section 3](#), is nonetheless vitally important for these models as well.

3. How Strong and Rigid?

Many building codes in the U.S.A. specify that laundry floors must have a minimum live load capacity of 150 pounds per square foot (732 kilograms per square meter). However, even compliance with this or any other standard does not necessarily guarantee sufficient rigidity. In any event, it is the sole responsibility of the owner/user to assure that the floor and/or any other supporting structure exceeds not only all applicable building codes, but also that the floor and/or any other supporting structure for each washer-extractor or group of washer-extractors actually has sufficient strength and rigidity, plus a reasonable factor of safety for both, to support the weight of all the fully loaded machine(s) including the weight of the water and goods, and including the published 360° rotating sinusoidal RMS forces that are transmitted by the machine(s). Moreover, the floor, foundation, or other supporting structure must have sufficient

rigidity (i.e., a natural or resonant frequency many times greater than the machine speed with a reasonable factor of safety); otherwise, the mentioned 360° rotating sinusoidal RMS forces can be multiplied and magnified many times. It is especially important to consider all potential vibration problems that might occur due to all possible combinations of forcing frequencies (rotating speeds) of the machine(s) compared to the natural frequencies of the floor and/or any other supporting structure(s). A qualified soil and/or structural engineer must be engaged for this purpose.

Figure 1: How Rotating Forces Act on the Foundation

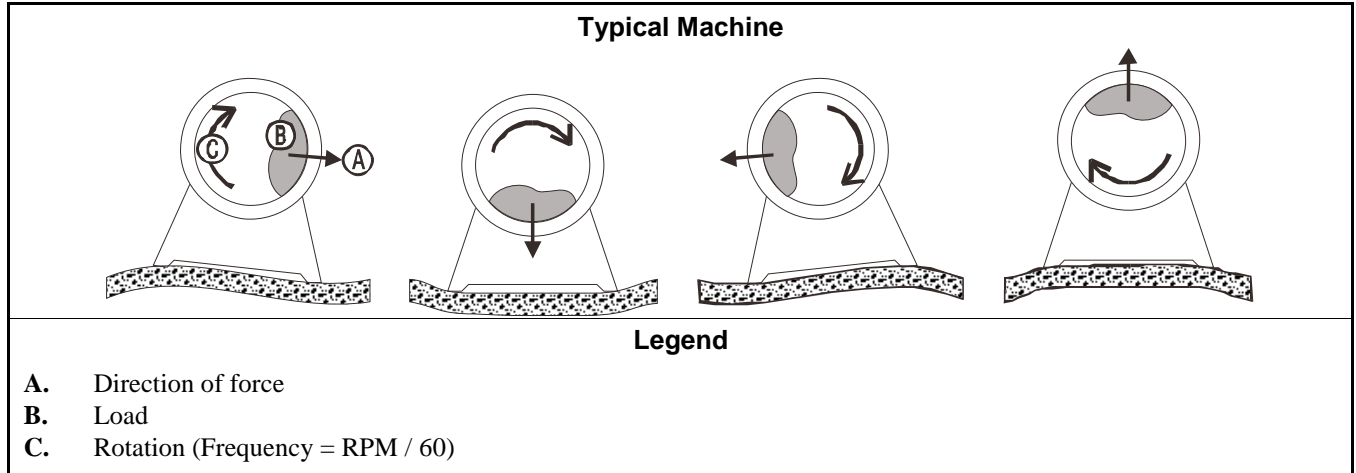

Figure 1 above is intended to depict both on-grade and above-grade installations and is equally applicable to flexibly-mounted washer-extractors, as well as to rigid models installed either directly on a floor slab or on a foundation poured integrally with the slab. Current machine data is available from Milnor® upon request. All data is subject to change without notice and may have changed since last printed. It is the sole responsibility of every potential owner to obtain written confirmation that any data furnished by Milnor® applies for the model(s) and serial number(s) of the specific machines.

— End of BIWUI02 —

Understanding the Tag Guidelines for the Models Listed Below

30010G5E	30010G5X	30015G5E	30015G5X	30015M4A	30015M4G	30015M4J
30015M4T	30015M6A	30015M6G	30015M6J	30015M6T	30015S5G	30015S5J
30015S5T	30015T5E	30015T5J	30015T5X	30015V7J	30022M5G	30022M5J
30022M5T	30022S4G	30022S4J	30022S4T	30022S5G	30022S5J	30022S5T
30022T5E	30022T5J	30022T5X	30022V6J			

Several installation guidelines and precautions are displayed symbolically, on tags placed at the appropriate locations on the machine. Some are tie-on and others are adhesive tags. Tie-on tags and white, adhesive tags may be removed after installation. Yellow adhesive tags must remain on the machine.

Understanding the Tag Guidelines for the Models Listed Below

Most tags contain only symbols (no words). A few are worded. The explanations below, start with the tag part number (displayed on the tag). If a tag contains no words, the meaning of the tag is explained below. If the tag contains words, the explanation below simply repeats the wording.

Display or Action

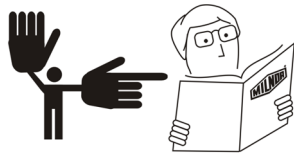

Explanation

Read the manual before proceeding. This symbol appears on most tags. The machine ships with a complete set of manuals. The safety, installation, and electrical schematic manuals are particularly important to installers.



B2TAG88005: This carefully built product was tested and inspected to meet Milnor performance and quality standards by



B2TAG93013: This bearing housing was lubricated at the Milnor factory before shipment.



B2TAG94081: Motor must rotate in this direction. On single motor washer-extractors and centrifugal extractors, the drive motor must turn in this direction during draining and extraction. This tag is usually wrapped around a motor housing. If the motor turns in the opposite direction when the machine is first tested, the electrical hookup is incorrect and must be reversed as explained in the schematic manual.

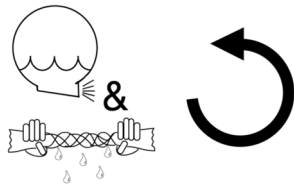

B2TAG94097: The cylinder must rotate **counterclockwise** during draining and extraction (spin) when viewed from here (rear of machine). Otherwise, reverse the electric power connections, as explained in the schematic manual.

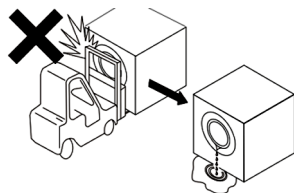

B2TAG94099: Do not strike the shell door when fork-lifting. This can cause the door to leak.

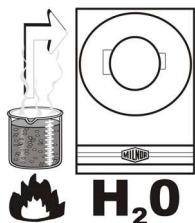

B2T2001013: Hot water connection.

Display or Action

Explanation

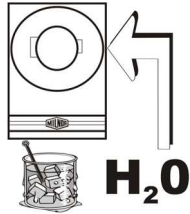

B2T2001014: Cold water connection.

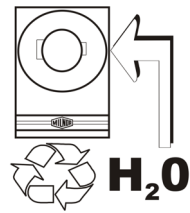

B2T2001015: Reuse (third) water connection.

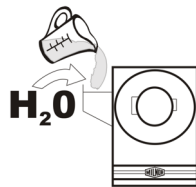

B2T2001016: Flushing water connection. This is the water that goes into the supply compartment or pumped chemical manifold to flush chemicals into the machine.



B2T2003001: Hold the side of the connection stationary with a wrench as you tighten the connection with another wrench. Otherwise, you may twist components, such as valves, damaging them.



B2T2003002: CAUTION: Equipment and Textile Damage Hazards—Chemicals leaked into the machine, particularly when it is idle, can destroy machine components and textiles left in the machine. Ensure the chemical system prevents dribbling, siphoning, or any other unintentional release of chemicals. Inspect regularly for proper operation and evidence of damage. Consult Milnor document BIWUUI03 “Avoiding Damage from Allied Remote Chemical Delivery Systems”.

— End of BIUUI02 —

Avoiding Damage From Allied Remote Chemical Delivery Systems

Milnor® does not manufacture or supply remote chemical delivery systems and this document is meant only to illustrate some of the possible problems that can be minimized during installation of such systems by the chemical supply company. Milnor washer-extractors and CBW® batch washers (tunnels) are available with convenient inlets for such systems (see Figure 1). Most common of the types of systems currently used in commercial laundering operations are pumped chemical systems. Other types, such as constant pressure, re-circulating ring main systems have also been, and may continue to be used with Milnor equipment.

This document warns about some of the possible hazards posed by chemical systems and lists certain requirements needed to minimize those hazards. The procedures for interfacing with allied chemical systems and information pertinent to chemical use in general are provided elsewhere in the product manuals (see Note 1).

Figure 1: Pumped Chemical Inlets on CBW Batch Washer



Note 1: Misuse of laundering chemicals (such as injecting excessive concentrations of chlorine bleach or permitting acid sours to react with hypo chlorite) due to incorrect formulation can also be hazardous. Information pertinent to chemical use is provided elsewhere in the product manuals.

1. How a Chemical System Can Damage the Machine It Serves

Milnor has manufactured washer-extractors and tunnel washers with the same stainless steel specification since its founding. Every batch of steel used is certified and documented by the steel mill. Testing of samples damaged by corrosion have, in every case, proven the steel to be well within the AISI 304 specification.

Chemical products commonly found in the laundry industry, when used in **established** dosages and proper operating parameters, under the auspices of an experienced chemical specialist, should produce satisfactory results, with no consequential detrimental effects. The industry has published standards in Riggs and Sherrill, “Textile Laundering Technology”. However, the stainless steel can be damaged and even destroyed by **abnormal** contact with chlorine bleach, hydrofluosilicic acid and other commonly used chemicals, as will occur if chemicals are unintentionally leaked into the machine, particularly when it is no longer in use and especially when machine surfaces are dry.

Some chemical systems have been found to permit chemicals to dribble from the supply lines, or worse, to siphon from the supply tank into the machine, during operation and long after the system is shut down—as after working hours and during weekends. If this occurs, **deterioration (rusting) of the stainless steel and damage to any textiles therein will inevitably result. If this condition goes undetected, machine damage is likely to be catastrophic.** No machine is immune to such damage.



CAUTION [1]: Equipment and Textile Damage Hazards—Chemicals leaked into the machine, particularly when it is idle can destroy machine components and textiles left in the machine. **Pellerin Milnor Corporation accepts absolutely no responsibility for damage to its equipment or to textiles therein from abnormal contact with chemicals.**

- Ensure that the chemical system prevents unintentional release of chemicals.
- Inspect regularly for proper operation and evidence of damage.

2. Requirements for Chemical Systems Used With Milnor Machines

It is the responsibility of the chemical system manufacturer and supplier to ensure that their system is safe for personnel and equipment. Some important points are described below.

- 2.1. **Ensure the System Cannot Siphon.**—The supply system must be designed to counteract any siphoning that could occur as a result of having a sealed supply line between the bottom of the chemical tank and the internal machine connection at the drain trough. As shown in the Figure 2 examples, if the pump (P) and/or the valving does not provide positive closure and there is no vacuum breaker protection, siphoning is likely to occur. In each of the Figure 2 illustrations, the volume of chemical in the tank above the siphon level (S), and indicated by shading, will flow into the machine.

Figure 2: Siphoning From the Chemical Tank into the Machine

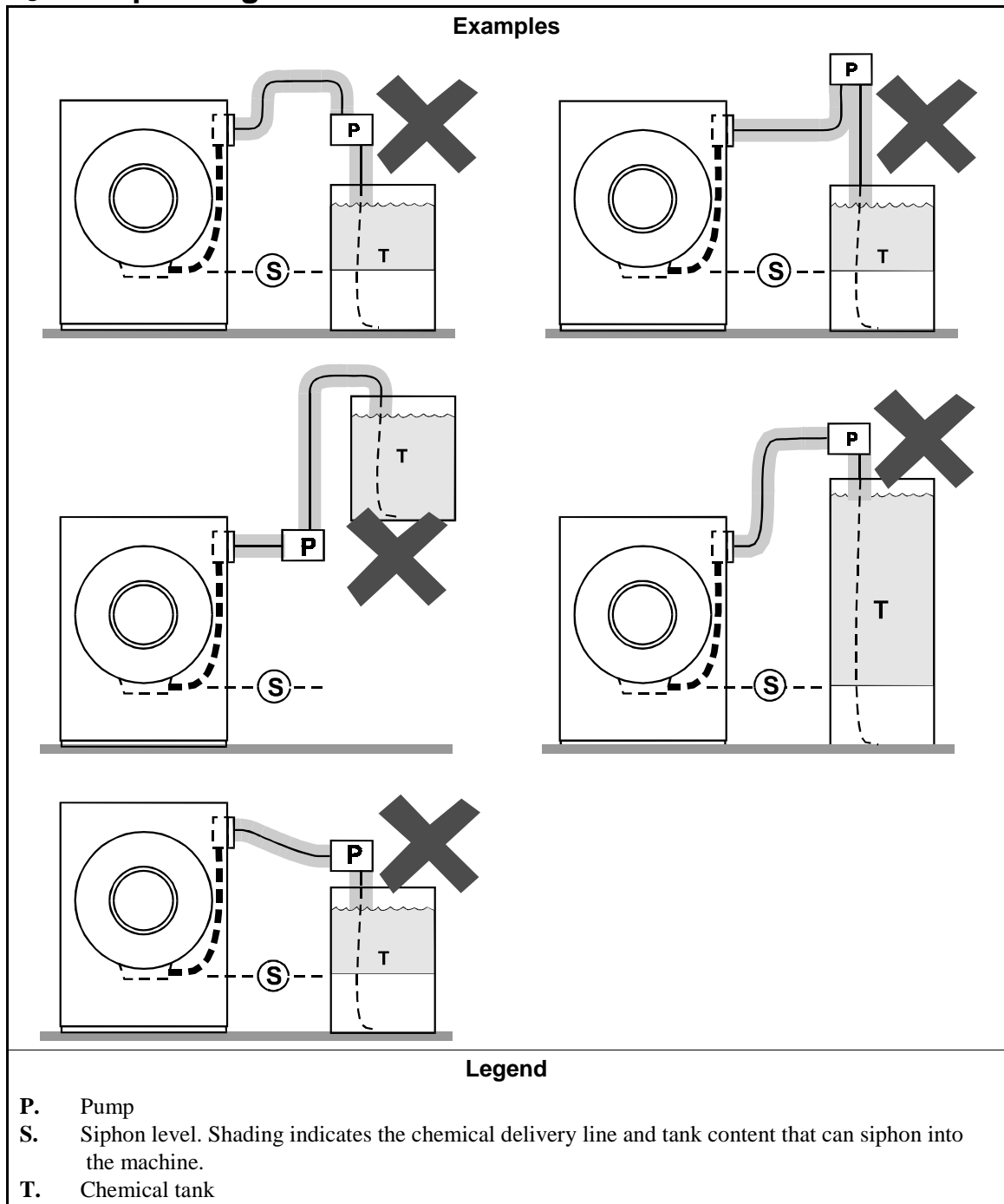

2.2. **Ensure the Chemical Lines Cannot Dribble**—The pumped chemical system may provide a means of positively closing the chemical line at the pump location, but not at the injection site. Hence, any concentrated chemical that remains in the injection line between the pump and the machine is free to flow into the machine. Some examples of this are shown in Figure 3.

**Figure 3: Dribbling From Chemical Supply Line Into Machine
(assumes positive closure at the pump)**

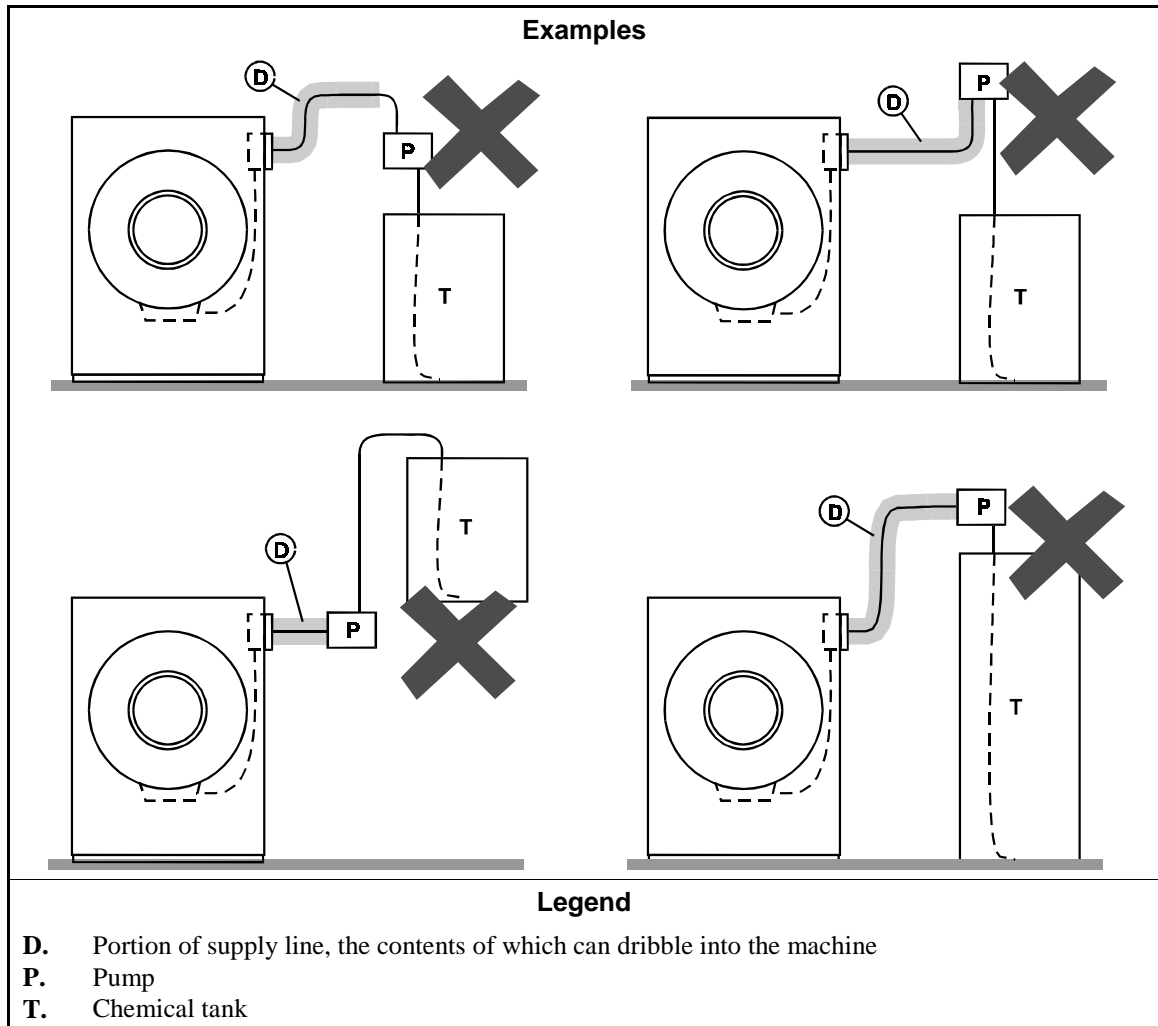

3. Design and Installation Recommendations

It is the responsibility of the chemical system manufacturer and supplier to use whatever measures are necessary to ensure that their system is safe for personnel and equipment. The following are some of the possible methods the manufacturer or supplier may wish to use, as appropriate.

- 3.1. **Siphoning: Positively close the line.**—If the pump does not provide positive closure when the system is off, employ a shutoff valve in the line to serve this purpose.
- 3.2. **Siphoning: Break the siphon.**—Provide an air gap or vacuum breaker in the chemical delivery line. This must be located above the “full” line of the tank.
- 3.3. **Dribbling: Flush the entire chemical delivery line.**—If any concentrated chemical that remains in the injection line between the pump and the machine is free to flow into the machine, employ a system that flushes the entire line between the pump and the injection point with fresh water after each injection.

- 3.4. **Dribbling: Locate the entire chemical line below the machine inlet.**— Assuming the chemical system does not retain any line pressure and that the pump provides positive closure when the system is off, locate the entire chemical delivery line below the level of the chemical inlet. An example of this is shown in Figure 4.

Figure 4: Locating a Pumped Chemical System With Positive Closure To Protect Against Machine Damage

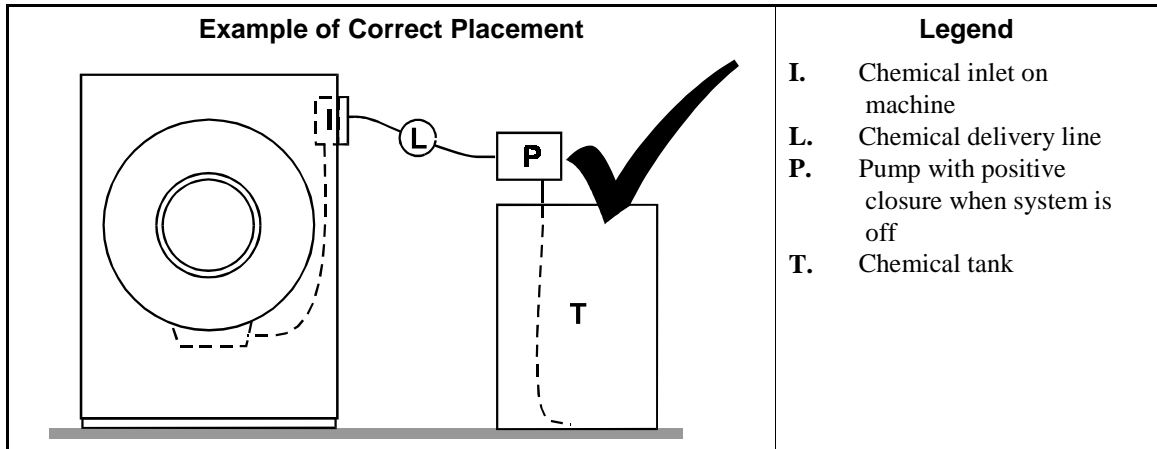

4. Guarding Against Leaks

All personnel who may work with the chemical system (e.g., chemical system manufacturer, chemical system supplier, chemical supplier, operator, maintenance personnel) should be vigilant in observing for leaks in the system. When connecting, or reconnecting chemical lines, whether at installation, after taking samples, or when replacing components, at a minimum ensure that:

1. the proper components are used,
2. all connections are the proper fit, and
3. all components are securely connected.



CAUTION [2]: Injury and Damage Hazards—Chemicals leaking from a chemical system may be corrosive or toxic. Such chemicals can injure personnel and damage equipment.

- Use care when connecting chemical lines.
- Inspect regularly for leaks.

— End of BIWUI03 —

Safety Placard Use and Placement

30015, 30022Txx & Vxx

BMP020103/2002145V
(Sheet 1 of 2)



Pellerin Milnor Corporation
P. O. Box 400, Kenner, LA 70063-0400

Litho in U.S.A.

Notes:

1. Replace placard immediately, if removed or unreadable.
2. Approximate locations of placards are shown. Mounting holes are provided on machine. Use #8 self-tapping screws.

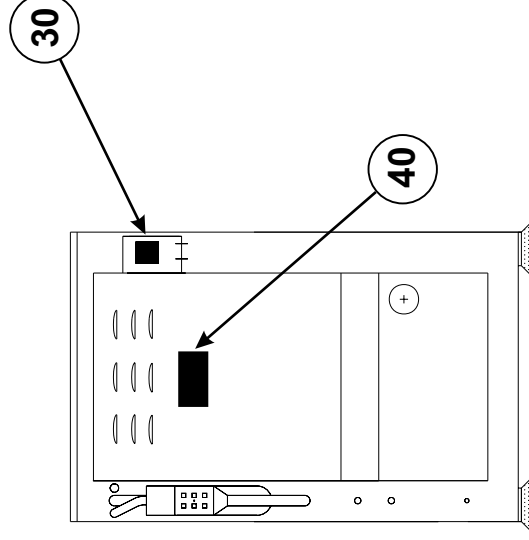

REAR VIEW

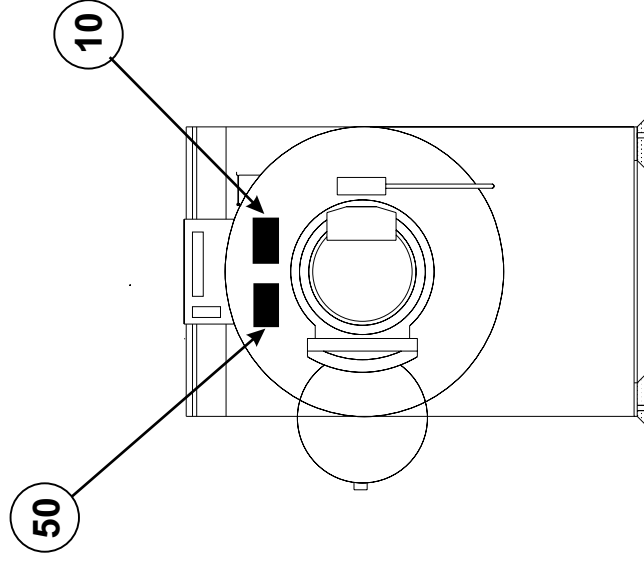

FRONT VIEW

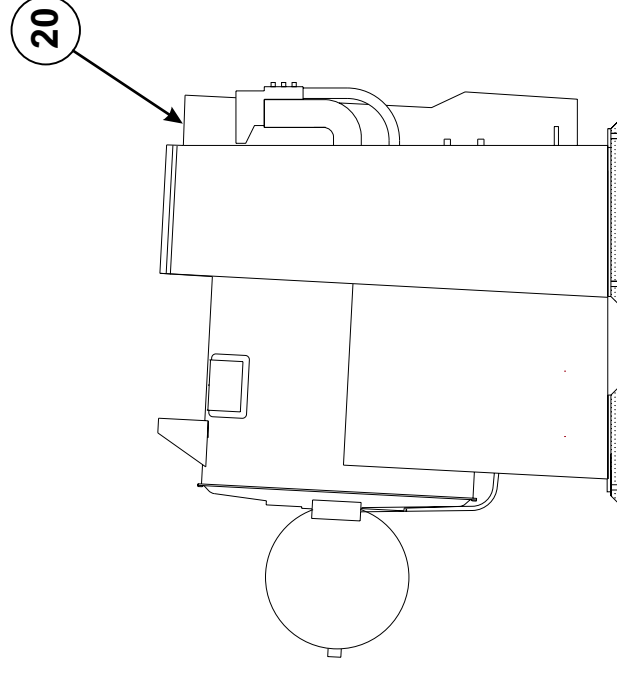

RIGHT VIEW

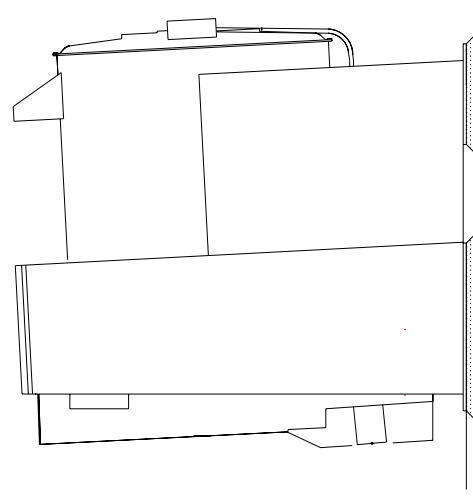

LEFT VIEW



Pellerin Milnor Corporation
P. O. Box 400, Kenner, LA 70063-0400

Litho in U.S.A.

Parts List—Safety Placard Placement

Find the correct assembly first, then find the needed components. The item letters (A, B, C, etc.) assigned to assemblies are referred to in the "Used In" column to identify which components belong to an assembly. The item numbers (1, 2, 3, etc.) assigned to components relate the parts list to the illustration.

Used In	Item	Part Number	Description	Comments
-----ASSEMBLIES-----				
none				
-----COMPONENTS-----				
all	10	01 10635A	NPLT:SHELL FORNT RIDGID-TCATA	
all	20	01 10375B	NPLT:ELEC HAZARD SMALL-TCATA	
all	30	01 10375C	NPLT:E-HAZARD SM VERTCL-TCATA	
all	40	01 10689A	NPLT:BELT HAZARD SM TCATA	
all	50	01 10699A	NPLT:SERV HZRD-PLYEST-TCATA	

Safety Placard Use and Placement ISO 30015, 30022Txx & Vxx

BMP020104/2002145V
(Sheet 1 of 2)



Pellerin Milnor Corporation
P. O. Box 400, Kenner, LA 70063-0400

Litho in U.S.A.

ISO Placards shown on this page

Notes:

1. Replace placard immediately, if removed or unreadable.
2. Approximate locations of placards are shown. Mounting holes are provided on machine. If aluminum placard use #8 self-tapping screws.

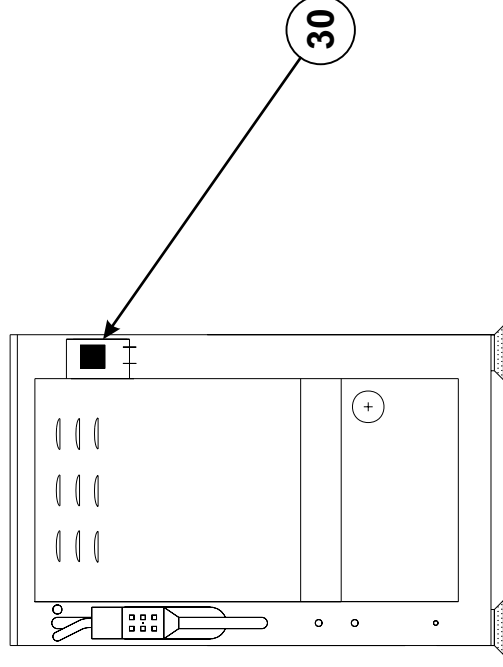

REAR VIEW

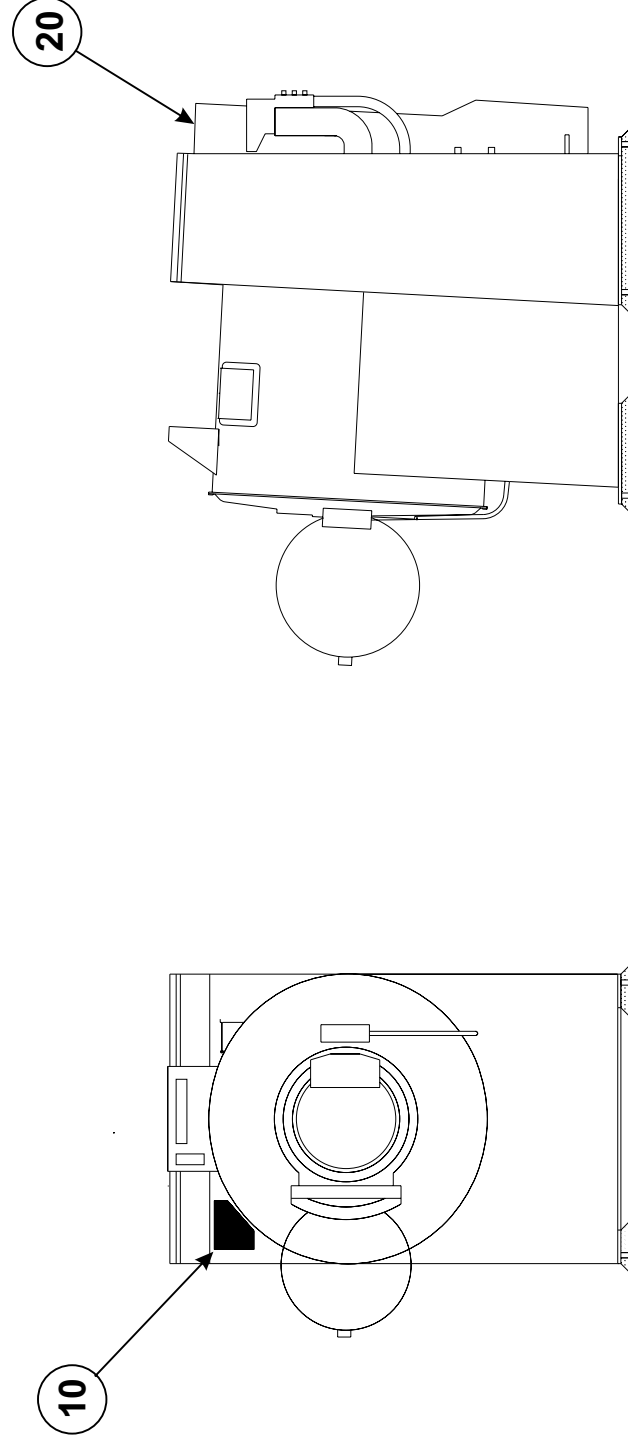

FRONT VIEW

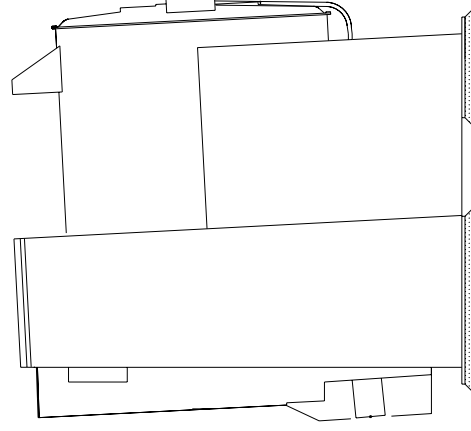

LEFT VIEW

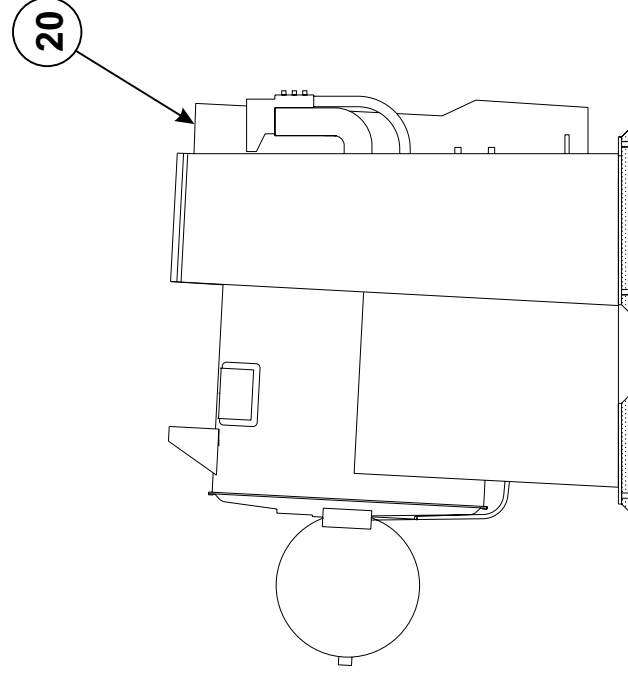

RIGHT VIEW



Pellerin Milnor Corporation
P. O. Box 400, Kenner, LA 70063-0400

Litho in U.S.A.

Parts List—Safety Placard Placement

Find the correct assembly first, then find the needed components. The item letters (A, B, C, etc.) assigned to assemblies are referred to in the "Used In" column to identify which components belong to an assembly. The item numbers (1, 2, 3, etc.) assigned to components relate the parts list to the illustration.

Used In	Item	Part Number	Description	Comments
-----ASSEMBLIES-----				
none				
-----COMPONENTS-----				
all	10	01 10635X	NPLT:30"WE RIGID WARNING ISO	
all	20	01 10375A	NPLT:VDE VOLTAGE WARN 1.25"	
all	30	01 10375	NPLTE:"WARNING" 2X2	

Guards and Covers
30015V7J, T5J,T5E 30022V6J, T5J, T5E

BMP000012/2001036V
(Sheet 1 of 2)



Pellerin Milnor Corporation
P. O. Box 400, Kenner, LA 70063-0400

Litho in U.S.A.

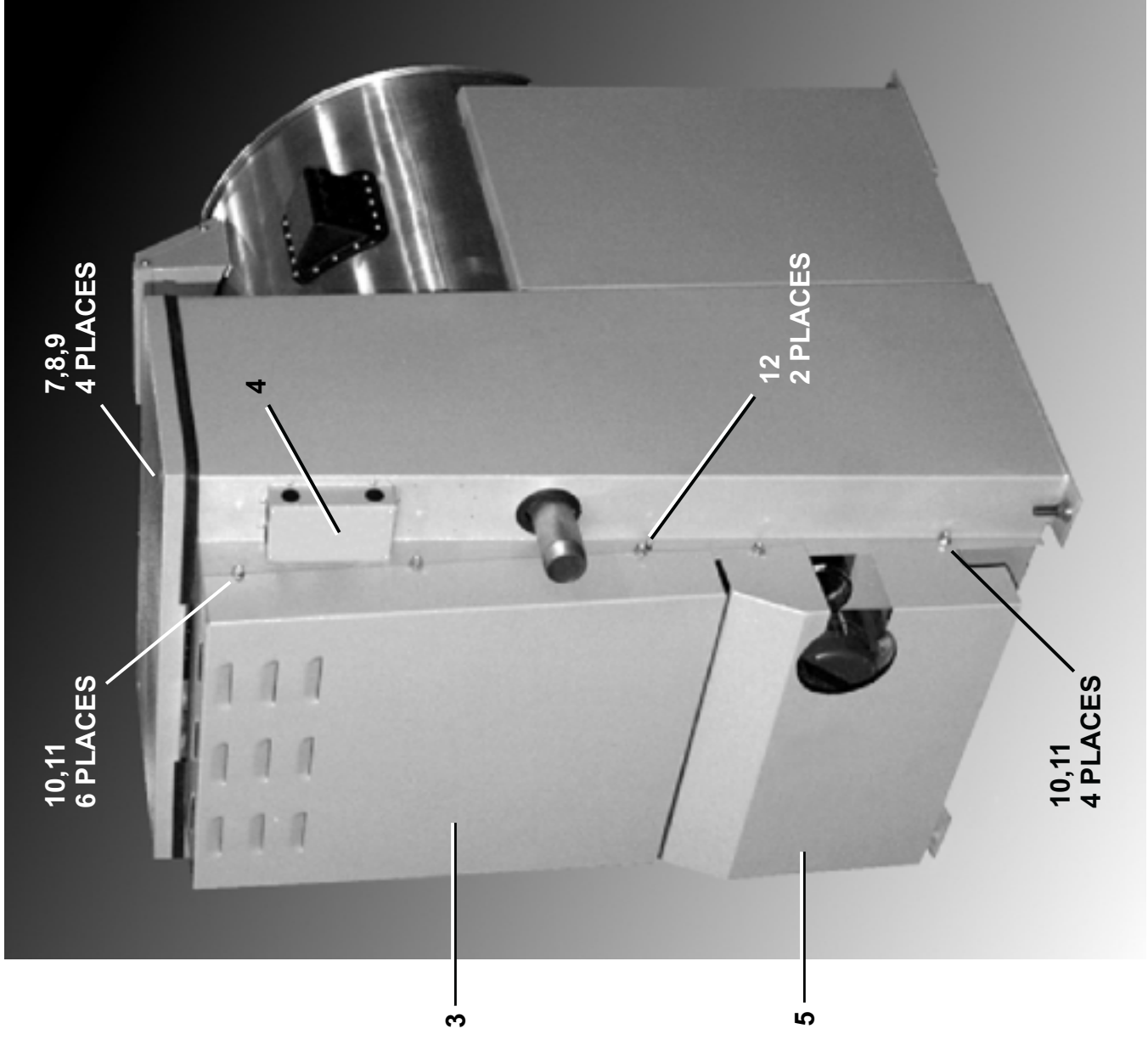
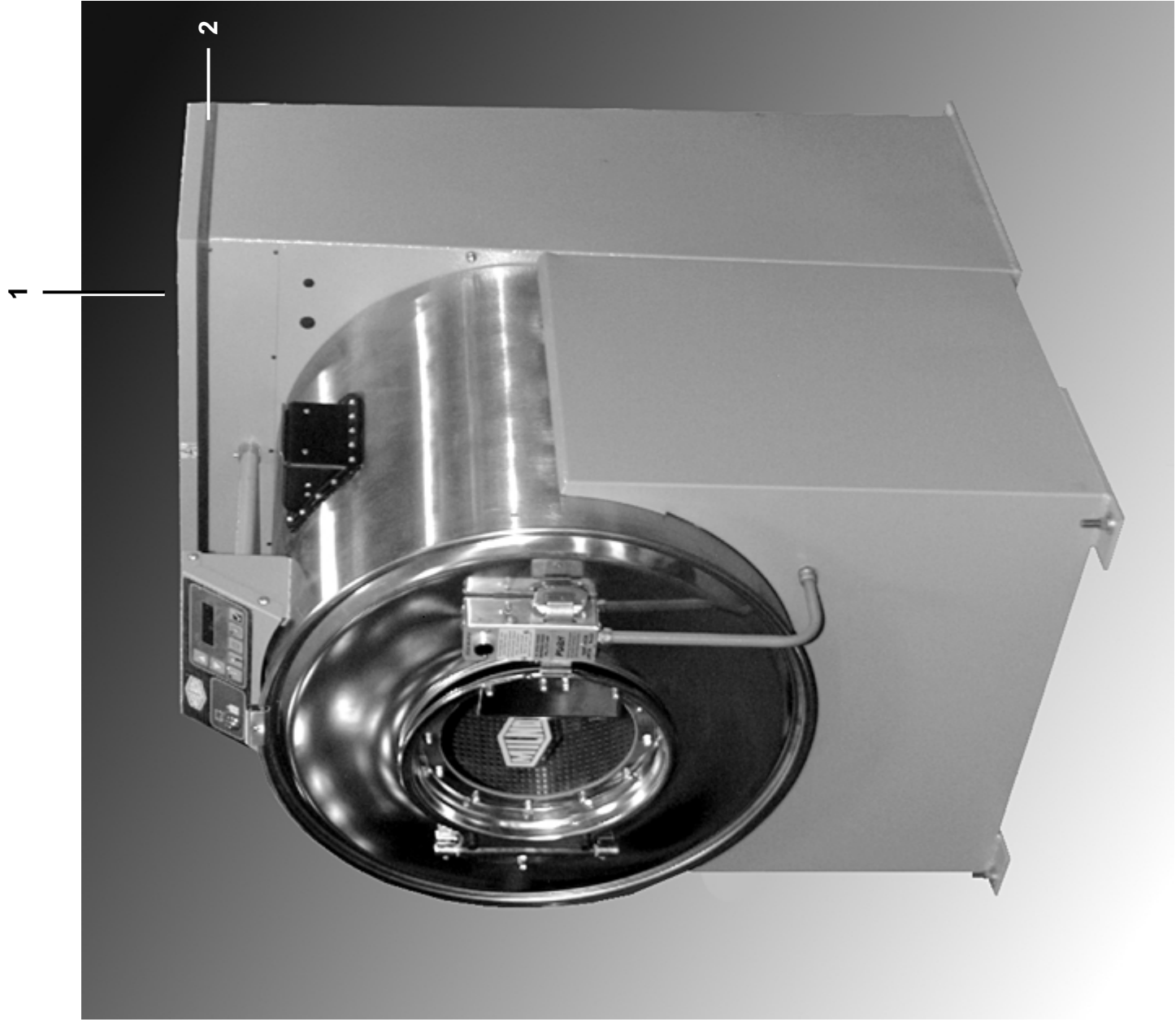

Guards and Covers

30015V7J, T5J,T5E 30022V6J, T5J, T5E



Pellerin Milnor Corporation
P. O. Box 400, Kenner, LA 70063-0400

BMP000012/2001036V
(Sheet 2 of 2)

Litho in U.S.A.

NOTE: KEEP DUST COVER IN PLACE AT ALL TIMES. REMOVE FOR SERVICING. BEHIND THIS COVER ARE THE BEARING HOUSING FILL AND DRAIN TUBES.

DUST COVER
6



Parts List—Guards and Covers

Find the correct assembly first, then find the needed components. The item letters (A, B, C, etc.) assigned to assemblies are referred to in the "Used In" column to identify which components belong to an assembly. The item numbers (1, 2, 3, etc.) assigned to components relate the parts list to the illustration.

Used In	Item	Part Number	Description	Comments
			-----COMPONENTS-----	
all	1	W2 03699A	*CONSOLE TOP WELDMENT	
all	2	02 03344	TRIM=REAR CONSOLE TOP 7FT/PC	
all	3	X2 03497A	GUARD REAR BELT	
all	4	03 C4X7	COVER:SYSTEM 7 LIQUID SUPPLY	
all	5	W2-03795B	00342# *WLMT=LOWER COVER-STEAM F0141	
all	6	03 C1824V	DUST COVER-30"V6J BELT	
all	7	15K120	HXCAPSCR 3/8-16UNC2AX2 GR5 ZIN	
all	8	02 03344	TRIM=REAR CONSOLE TOP 7FT/PC	
all	9	17N070P	RETAIN NUT 3/8-16 #S10100-27	
all	10	15P200	TRDCUT-F HXWASHD 3/8-16X3/4NIK	
all	11	15U346	FLAWASH 7/8X3/8X.030 NATURAL N	
all	12	15P185	TRDCUT-F HXHD 1/4-20UNC2AX3/4	
all	14	15P010	PHILPAN TRDCUTSCRTP10-24X1/2S	

Section
Service and Maintenance

1

Preventive Maintenance

1. Lubrication Guidelines

As required by the warranty, to ensure safe operation, and to achieve optimum performance and service life from Milnor® washer-extractors, the schedules, instructions, and precautions herein must be strictly followed.



WARNING 1: Entangle and Crush Hazard—Belts and pulleys can entangle and crush body parts.

- Lock OFF and tag out power at the wall disconnect before servicing, except where specifically instructed otherwise in this section.
- Insure belt and pulley guards are in place during service procedures.
- Permit only qualified maintenance personnel to perform these procedures.

2. 30022C4x, 30022T5x and 30022V6J Main Bearing Maintenance

30022C4x, 30022T5x and 30022V6J main bearing housings are oil-filled and require periodic draining and refilling (see below).

See the appropriate “MAIN BEARING ASSEMBLY” (see Table of Contents) during this procedure.

1. Remove the drain plug on the bottom of the main bearing housing and allow the bearing housing to drain completely (Figure 1). Inspect the leak-off, drained oil, and magnetic drain plug for water and/or metal particles. Install the drain plug. Water and/or metal particles can indicate worn or damaged seals and bearings.
2. Locate the two 1/2" plastic tubes secured to the electrical control chassis. Clean the surrounding area and remove the cork stoppers from each (Figure 2).
3. Strictly following lubrication specifications, refill the bearing housing. After refilling the bearing housing, re-install the cork stoppers and clean any excess lubricant from the machine.

3. Preventive Maintenance Schedule

Table 1: Preventive Maintenance Checklist

Component		Action	Frequency	Specifications/Figure
Bearing Housing	Oil	Remove fill, vent and drain stoppers. Refill 22 ounces (634 grams)	Every four months	High quality SAE 30 to 50 (ISO 100 - 220) single weight heavy duty motor oil (non-detergent if available). See "Oil Drain and Water Leak-off" and also see "30022C4x,..Fill/Vent Hoses"
	Drive Train	Belts and pulleys	Check for wear, replace as required	Monthly
	Motors (if equipped with grease fittings) (See Note 2)	See "Baldor Motor Maintenance....," in this manual (See Note 3)	Every three Months	See motor nameplate. If not specified, use Shell Alvania (or equivalent). See "Motor Grease Points"
Drive Inverter	Inverter	Verify fan operation. Vacuum out inverter vents.	Monthly	See "Inverter Maintenance Points"
Hoses, Clamps, and Connections	Inlet, drain, and chemical hoses and connections	Check for leaks, cracks and bulges	Monthly	
Bolts	Foundation	Check bolt tightness and wear	Monthly	See dimensional drawings
	Rear bearing reinforcement plate and throughout machine			See "30022C4x,..Rear Reinforcement Plate" for 36021C4E and 36026V5J machines, or "42026V6J Rear Reinforcement Plate" for 42026V6J machines.

Note 1: Monthly/200 hours = Once a month or once every 200 operating hours, whichever comes first.

Note 2: Do not over-lubricate motors. Over-lubrication of a motor can seriously damage it by forcing grease into motor windings.

Note 3: If motor manufacturer's instructions conflict with manual section MSSM0274AE, follow manufacturers instructions. Motors are warranted by the manufacturers, not by Milnor.

4. Maintenance Points

Figure 1: 30022C4x, 30022T5x, 36021C4E and 36026V5J Oil Drain and Water Leak-off

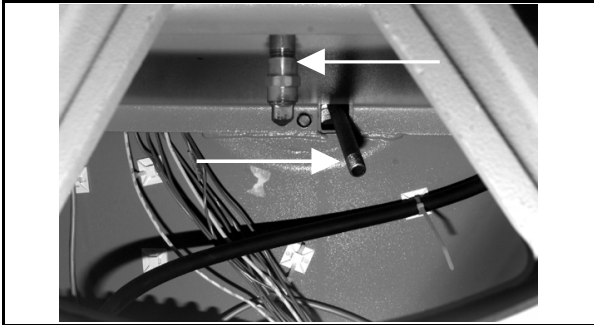

Figure 2: 30022C4x, 30022T5x, 36021C4E and 36026V5J Oil Fill/Vent Hoses (use either hose for filling)

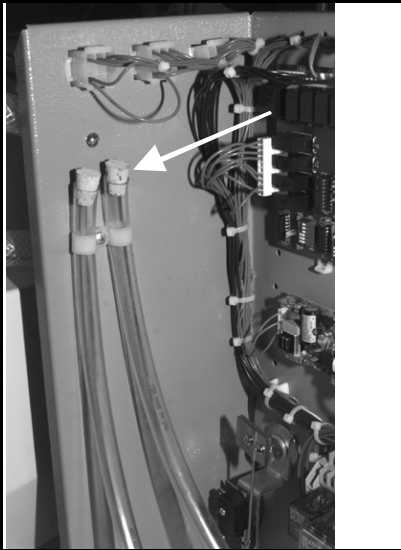

Figure 3: Drive Train Pulleys and Belts (30022V6J shown)

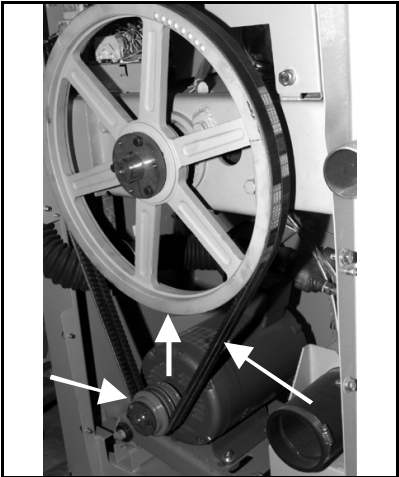
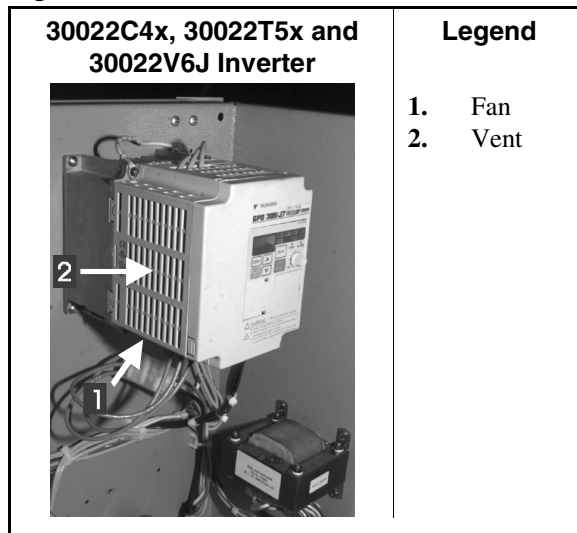
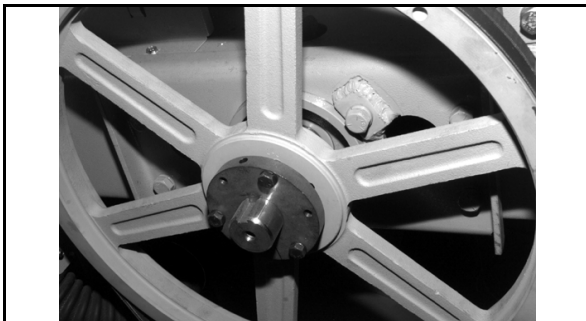

Figure 4: Inverter Maintenance Points



**Figure 5: 30022C4x, 30022T5x, 30022V6J,
36021C4E and 36026V5J Rear Bearing
Reinforcement Plate (30022VxJ shown)**



— End of BIRQUM01 —

Fastener Torque Requirements

Torque requirements for other fasteners are specified in the specific document which describes the assembly. **If fastener torque specifications or threadlocking compound requirements in an assembly document vary from the specifications in this document, use the assembly document.**

Figure 1: Common Bolts Used in Milnor Equipment

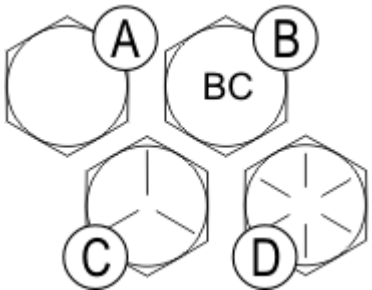
Bolt Head Identifying Marks	Legend
	<p>A. SAE Grades 1 and 2, ASTM A307, and stainless steel B. ASTM A354 Grade BC C. SAE Grade 5, ASTM A449 D. SAE Grade 8 and ASTM A354 BD</p>

1. Torque Values

The tables below list the standard size, grade, threadlocking compound, and torque requirements for fasteners commonly used on Milnor® equipment.

Note 1: Data derived from Pellerin Milnor® Corporation “Bolt Torque Specification” (bolt_torque_milnor.xls/2002096).

1.1. Carbon Steel Fasteners

1.1.1. Without Threadlocking Compound

Table 1: Torque Values for Dry Fasteners 5/16-inch and Smaller

Bolt Size	Bolt Grade							
	Grade 2		Grade 5		Grade 8		Grade BC	
	Pound-Inches	N-m	Pound-Inches	N-m	Pound-Inches	N-m	Pound-Inches	N-m
1/4 x 20	66	7	101	11	143	16	126	14
1/4 x 28	76	9	116	13	163	18	--	--
5/16 x 18	136	15	209	24	295	33	258	29
5/16 x 24	150	17	232	26	325	37	--	--

Fastener Torque Requirements

Table 2: Torque Values for Dry Fasteners Larger Than 5/16-inch

Bolt Size	Bolt Grade							
	Grade 2		Grade 5		Grade 8		Grade BC	
	Pound-feet	N-m	Pound-feet	N-m	Pound-feet	N-m	Pound-feet	N-m
3/8 x 16	20	27	31	42	44	59	38	52
3/8 x 24	23	31	35	47	50	68	--	--
7/16 x 14	32	43	49	66	70	95	61	83
7/16 x 20	36	49	55	75	78	105	--	--
1/2 x 13	49	66	75	102	107	145	93	126
1/2 x 20	55	75	85	115	120	163	--	--
9/16 x 12	70	95	109	148	154	209	134	182
9/16 x 18	78	106	121	164	171	232	--	--
5/8 x 11	97	131	150	203	212	287	186	252
5/8 x 18	110	149	170	231	240	325	--	--
3/4 x 10	172	233	266	361	376	510	329	446
3/4 x 16	192	261	297	403	420	569	--	--
7/8 x 9	167	226	429	582	606	821	531	719
7/8 x 14	184	249	473	641	668	906	--	--
1 x 8	250	339	644	873	909	1232	796	1079
1 x 12	274	371	704	954	994	1348	--	--
1 x 14	281	381	723	980	1020	1383	--	--
1 1/8 x 7	354	480	794	1077	1287	1745	1126	1527
1 1/8 x 12	397	538	891	1208	1444	1958	--	--
1 1/4 x 7	500	678	1120	1519	1817	2464	1590	2155
1 1/4 x 12	553	750	1241	1682	2012	2728	--	--
1 3/8 x 6	655	888	1469	1992	2382	3230	2085	2827
1 3/8 x 12	746	1011	1672	2267	2712	3677	--	--
1 1/2 x 6	869	1178	1949	2642	3161	4286	2767	3751
1 1/2 x 12	979	1327	2194	2974	3557	4822	--	--

Table 3: Torque Values for Plated Fasteners 5/16-inch and Smaller

Bolt Size	Bolt Grade							
	Grade 2		Grade 5		Grade 8		Grade BC	
	Pound-Inches	N-m	Pound-Inches	N-m	Pound-Inches	N-m	Pound-Inches	N-m
1/4 x 20	49	6	76	9	107	12	95	11
1/4 x 28	56	6	88	10	122	14	--	--
5/16 x 18	102	12	156	18	222	25	193	22
5/16 x 24	113	13	174	20	245	28	--	--

Table 4: Torque Values for Plated Fasteners Larger Than 5/16-inch

Bolt Size	Bolt Grade							
	Grade 2		Grade 5		Grade 8		Grade BC	
	Pound-feet	N-m	Pound-feet	N-m	Pound-feet	N-m	Pound-feet	N-m
3/8 x 16	15	20	23	31	33	44	29	38
3/8 x 24	17	23	26	35	37	49	--	--
7/16 x 14	24	32	37	50	52	71	46	61
7/16 x 20	27	36	41	55	58	78	--	--
1/2 x 13	37	49	56	76	80	106	70	93
1/2 x 20	41	55	64	85	90	120	--	--
9/16 x 12	53	70	81	110	115	153	101	134
9/16 x 18	59	79	91	122	128	174	--	--
5/8 x 11	73	97	113	150	159	212	139	186
5/8 x 18	83	110	127	172	180	240	--	--
3/4 x 10	129	173	200	266	282	376	246	329
3/4 x 16	144	192	223	297	315	420	--	--
7/8 x 9	125	166	322	430	455	606	398	531
7/8 x 14	138	184	355	474	501	668	--	--
1 x 8	188	250	483	644	682	909	597	796
1 x 12	205	274	528	716	746	995	--	--
1 x 14	210	280	542	735	765	1037	--	--
1 1/8 x 7	266	354	595	807	966	1288	845	1126
1 1/8 x 12	298	404	668	890	1083	1444	--	--
1 1/4 x 7	375	500	840	1120	1363	1817	1192	1590
1 1/4 x 12	415	553	930	1261	1509	2013	--	--
1 3/8 x 6	491	655	1102	1470	1787	2382	1564	2085
1 3/8 x 12	559	758	1254	1672	2034	2712	--	--
1 1/2 x 6	652	870	1462	1982	2371	3161	2075	2767
1 1/2 x 12	733	994	1645	2194	2668	3557	--	--

1.1.2. With Threadlocking Compound

Table 5: Threadlocking Compound Selection by Bolt Size

LocTite Product	Bolt Size			
	1/4"	1/4" – 5/8"	5/8" – 7/8"	1" +
LocTite 222	OK			
LocTite 242		OK		
LocTite 262			OK	
LocTite 272			High temperature	
LocTite 277				OK

Fastener Torque Requirements

Table 6: Torque Values for Applications of LocTite 222

Bolt Size	Bolt Grade							
	Grade 2		Grade 5		Grade 8		Grade BC	
	Pound-inches	N-m	Pound-inches	N-m	Pound-inches	N-m	Pound-inches	N-m
1/4 x 20	60	7	96	11	132	15	108	12
1/4 x 28	72	8	108	12	144	16	--	--

Table 7: Torque Values for Applications of LocTite 242

Bolt Size	Bolt Grade							
	Grade 2		Grade 5		Grade 8		Grade BC	
	Pound-feet	N-m	Pound-feet	N-m	Pound-feet	N-m	Pound-feet	N-m
5/16 x 18	11	15	17	23	25	34	22	30
5/16 x 24	13	18	19	26	27	37	27	37
3/8 x 16	20	27	31	42	44	60	38	52
3/8 x 24	23	31	35	47	50	68	--	--
7/16 x 14	32	43	49	66	70	95	61	83
7/16 x 20	36	49	55	75	78	106	--	--
1/2 x 13	49	66	75	102	107	145	93	126
1/2 x 20	55	75	85	115	120	163	--	--
9/16 x 12	70	95	109	148	154	209	134	182
9/16 x 18	78	106	121	164	171	232	--	--
5/8 x 11	97	132	150	203	212	287	186	252
5/8 x 18	110	149	170	230	240	325	--	--

Table 8: Torque Values for Applications of LocTite 262

Bolt Size	Bolt Grade							
	Grade 2		Grade 5		Grade 8		Grade BC	
	Pound-feet	N-m	Pound-feet	N-m	Pound-feet	N-m	Pound-feet	N-m
3/4 x 10	155	210	240	325	338	458	296	401
3/4 x 16	173	235	267	362	378	512	--	--
7/8 x 9	150	203	386	523	546	740	477	647
7/8 x 14	165	224	426	578	601	815	--	--

Table 9: Torque Values for Applications of Loctite 272 (High Temperature)

Bolt Size	Bolt Grade							
	Grade 2		Grade 5		Grade 8		Grade BC	
	Pound-feet	N-m	Pound-feet	N-m	Pound-feet	N-m	Pound-feet	N-m
1 x 8	350	475	901	1222	1272	1725	1114	1510
1 x 12	383	519	986	1337	1392	1887	--	--
1 x 14	393	533	1012	1372	1428	1936	--	--
1-1/8 x 7	496	672	1111	1506	1802	2443	1577	2138
1-1/8 x 12	556	754	1247	1691	2022	2741	--	--
1-1/4 x 7	700	949	1568	2126	2544	3449	2226	3018
1-1/4 x 12	774	1049	1737	2355	2816	3818	--	--
1-3/8 x 6	917	1243	2056	2788	3335	4522	2919	3958
1-3/8 x 12	1044	1415	2341	3174	3797	5148	--	--
1-1/2 x 6	1217	1650	2729	3700	4426	6001	3873	5251
1-1/2 x 12	1369	1856	3071	4164	4980	6752	--	--

Table 10: Torque Values for Applications of Loctite 277

Bolt Size	Bolt Grade							
	Grade 2		Grade 5		Grade 8		Grade BC	
	Pound-feet	N-m	Pound-feet	N-m	Pound-feet	N-m	Pound-feet	N-m
1 x 8	325	441	837	1135	1181	1601	1034	1402
1 x 12	356	483	916	1242	1293	1753	--	--
1 x 14	365	495	939	1273	1326	1798	--	--
1-1/8 x 7	461	625	1032	1399	1674	2270	1464	1985
1-1/8 x 12	516	700	1158	1570	1877	2545	--	--
1-1/4 x 7	650	881	1456	1974	2362	3202	2067	2802
1-1/4 x 12	719	975	1613	2187	2615	3545	--	--
1-3/8 x 6	851	1154	1909	2588	3097	4199	2710	3674
1-3/8 x 12	970	1315	2174	2948	3526	4781	--	--
1-1/2 x 6	1130	1532	2534	3436	4110	5572	3597	4877
1-1/2 x 12	1271	1723	2852	3867	4624	6269	--	--

1.2. Stainless Steel Fasteners

Table 11: Torque Values for Stainless Steel Fasteners 5/16-inch and Smaller

Nominal Bolt Size	316 Stainless		18-8 Stainless		18-8 Stainless with Loctite 767	
	Pound-Inches	N-m	Pound-Inches	N-m	Pound-Inches	N-m
1/4 x 20	79	9	76	9	45	5
1/4 x 28	100	11	94	11	56	6
5/16 x 18	138	16	132	15	79	9
5/16 x 24	148	17	142	16	85	10

Table 12: Torque Values for Stainless Steel Fasteners Larger Than 5/16-inch

Bolt Size	316 Stainless		18-8 Stainless		18-8 Stainless with Loctite 767	
	Pound-feet	N-m	Pound-feet	N-m	Pound-feet	N-m
3/8 x 16	21	28	20	27	12	16
3/8 x 24	23	31	22	29	13	18
7/16 x 14	33	44	31	42	19	25
7/16 x 20	35	47	33	45	20	27
1/2 x 13	45	61	43	58	26	35
1/2 x 20	47	64	45	61	27	37
9/16 x 12	59	81	57	77	34	46
9/16 x 18	66	89	63	85	38	51
5/8 x 11	97	131	93	125	56	75
5/8 x 18	108	150	104	141	62	84
3/4 x 10	132	179	128	173	77	104
3/4 x 16	130	176	124	168	75	101
7/8 x 9	203	275	194	263	116	158
7/8 x 14	202	273	193	262	116	157
1 x 8	300	406	287	389	172	233
1 x 14	271	367	259	351	156	211
1-1/8 x 7	432	586	413	560	248	336
1-1/8 x 12	408	553	390	529	234	317
1-1/4 x 7	546	740	523	709	314	425
1-1/4 x 12	504	683	480	651	288	390
1-1/2 x 6	930	1261	888	1204	533	722
1-1/2 x 12	732	992	703	953	422	572

2. Preparation



WARNING [1]: Fire Hazard—Some solvents and primer products are flammable.

- Use in a well ventilated area.
 - Do not use flammable products near ignition sources.
1. Clean all threads with a wire brush, a tap, or a die.
 2. Degrease the fasteners and the mating threads with a cleaning solvent. Wipe the parts dry.

Note 2: Loctite 7649 Primer N™ will remove grease from parts, but it costs more than a standard organic or petroleum solvent.

3. Prime the fasteners and the mating threads with Loctite 7649 Primer N™ or equal. Allow the primer to dry for at least one minute.

3. Application of Threadlocking Compound



CAUTION [2]: Malfunction Hazard—Improper application of threadlocking compounds may result in fasteners becoming loose from impact, heat, or vibration. Loose fasteners can cause the equipment to malfunction.

- Read and follow the threadlocking compound manufacturer's instructions and warnings.

Apply threadlocking compound to the thread engagement areas of fasteners and mating threads only.

Figure 2: Blind Hole

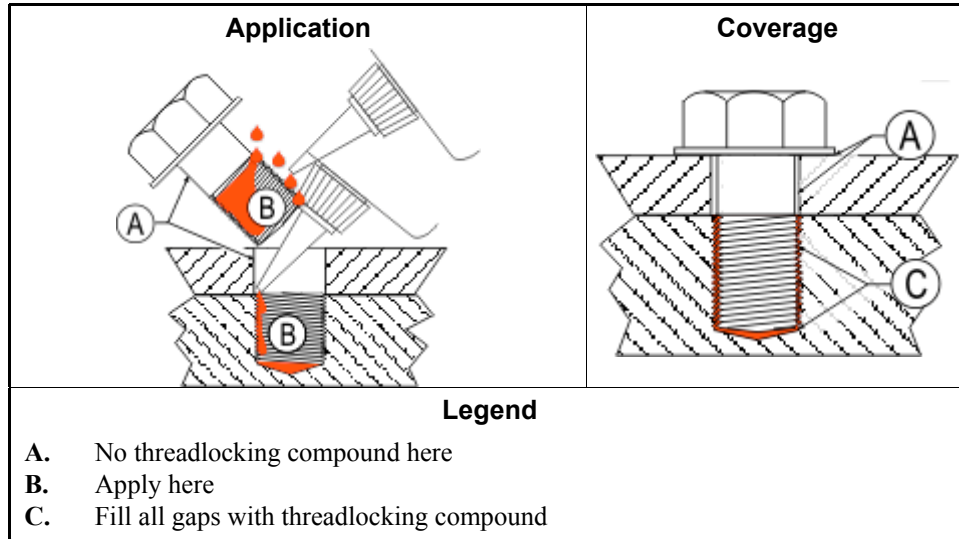

3.1. Blind Holes

1. Apply several drops of threadlocking compound down the female threads to the bottom of the hole.
2. Apply several drops of threadlocking compound to the bolt.
3. Tighten bolt to value shown in the appropriate table ([Table 5](#) through [Table 11](#)).

3.2. Through Holes

1. Insert bolt through assembly.
2. Apply several drops of threadlocking compound to the bolt thread area that will engage the nut.
3. Tighten bolt to value shown in the appropriate table ([Table 5](#) through [Table 11](#)).

Figure 3: Through Hole

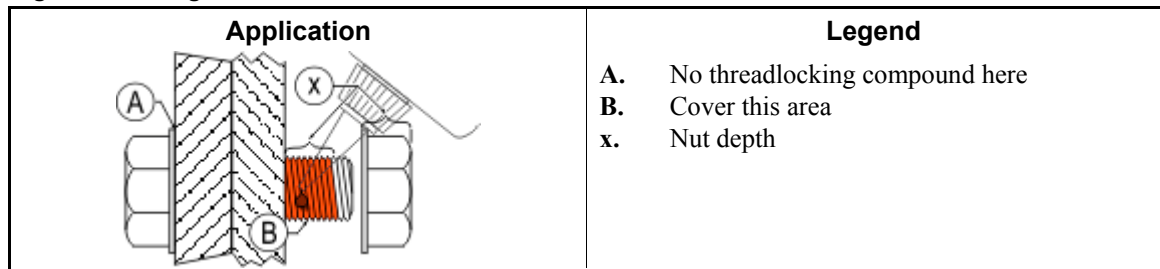

3.3. Disassembly—For low-strength and medium-strength products, disassemble with hand tools.

For high-strength products, apply localized heat for five minutes. Disassemble with hand tools while the parts are still hot.

Figure 4: Disassembly

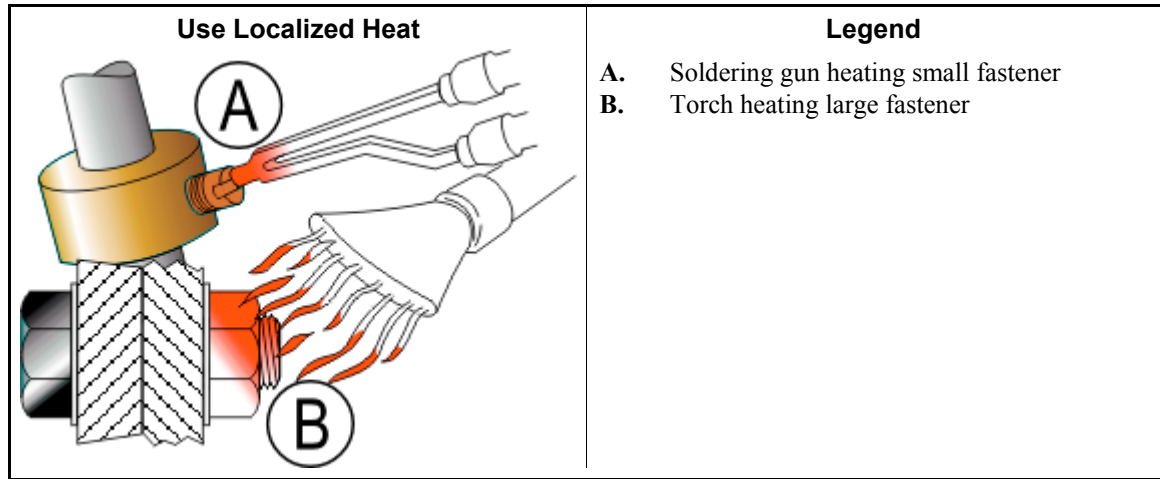

— End of BIUUM04 —

Section
Drive Assemblies

2

Drive Chart 30015T5J,T5E & 30022T5J,T5E

BMP0000006/2001036V
(Sheet 1 of 1)



Pellerin Milnor Corporation
P. O. Box 400, Kenner, LA 70063-0400

Litho in U.S.A.

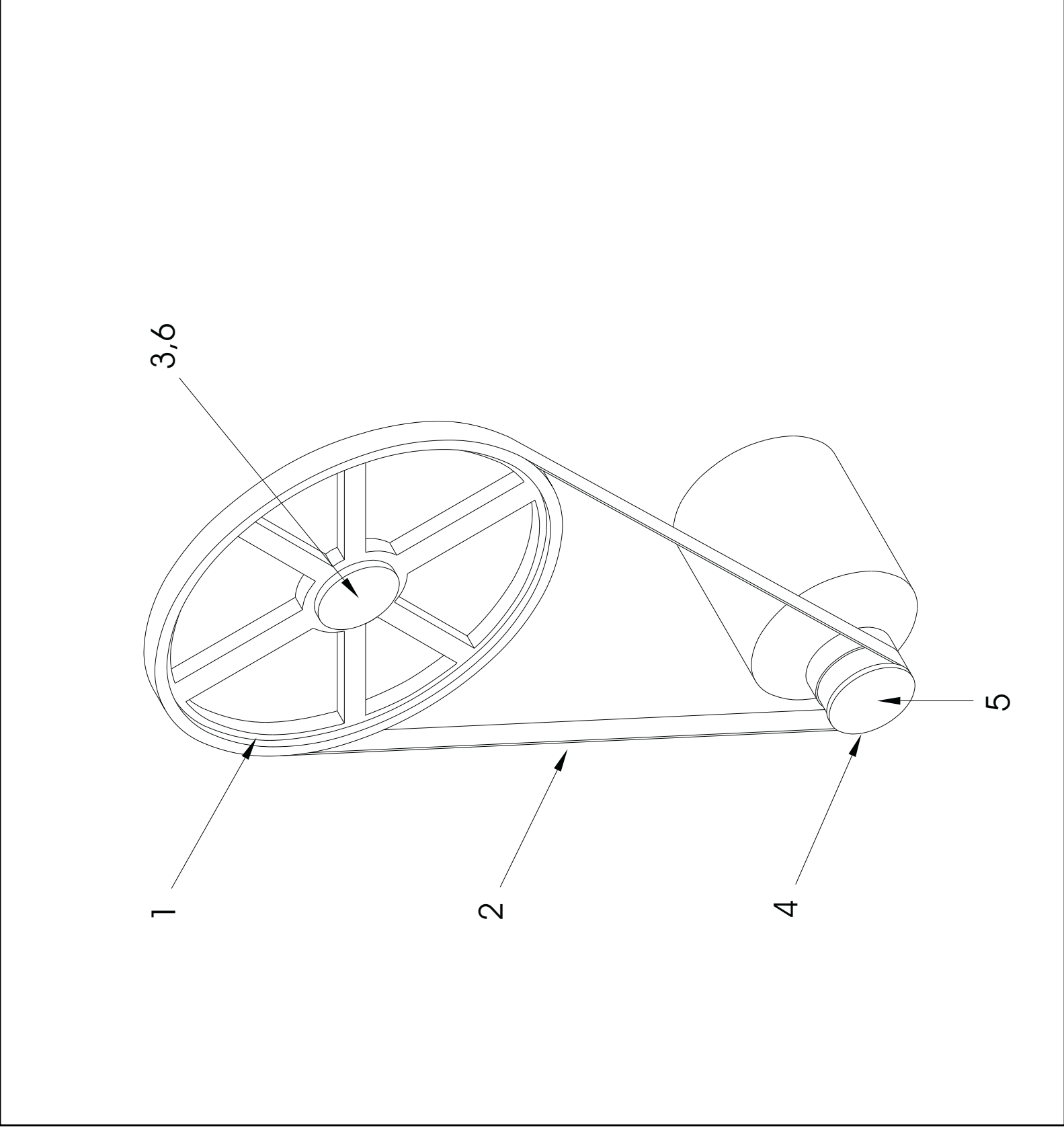

Parts List—Drive Chart
Find the correct assembly first, then find the needed components. The item letters (A, B, C, etc.) assigned to assemblies are referred to in the "Used In" column to identify which components belong to an assembly. The item numbers (1, 2, 3, etc.) assigned to components relate the parts list to the illustration.

Used In	Item	Part Number	Description	Comments
	A	D33 03260	94000Z DRIVE CHART-3015/22V4 60CYC	30015 & 30022T5J
			-----ASSEMBLIES-----	
			-----COMPONENTS-----	
all	1	562240R3SF	VPUL 3G3V22.4 (SF) MTO SPECIAL	
all	2	56VR082XB3	VBAND 3R3VX820 EA = 1 BELT	
all	3	56Q1KSF	1+1/2" BUSH VPUL QD TYPE SF	
all	4	560260R3JA	VPUL 3G3V2.60 QD TYPE JA	
all	5	56Q0RJA	7/8" BUSHING VPUL QD TYPE "JA"	
all	6	15E230	STRMACHKEY 3/8SQX2+1/2 TOL.+0	

Drive Chart 30015V7J & 30022V6J

BMP000007/2000455V
(Sheet 1 of 1)



Pellerin Milnor Corporation
P. O. Box 400, Kenner, LA 70063-0400

Litho in U.S.A.

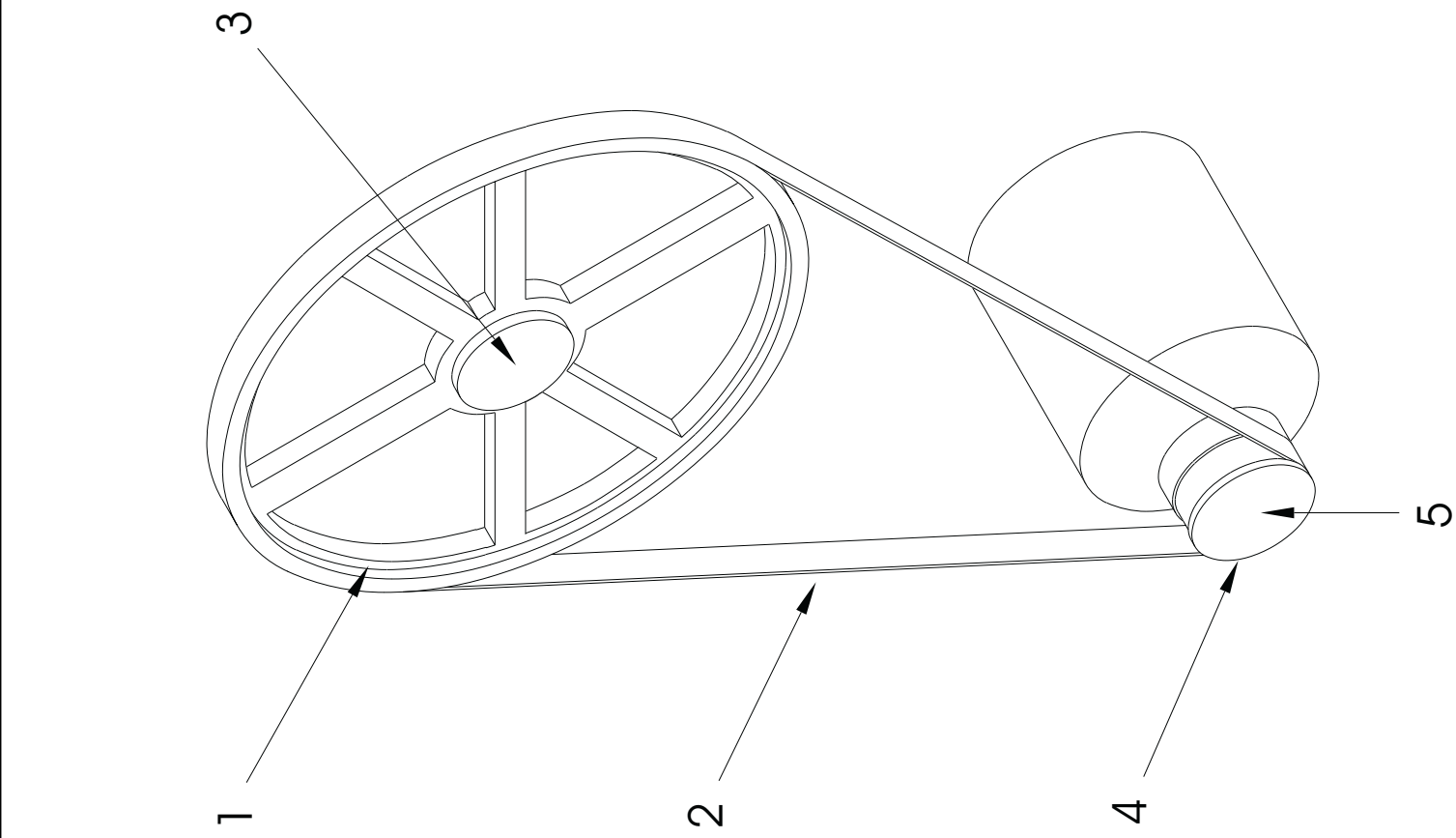

Parts List— Drive Chart
Find the correct assembly first, then find the needed components. The item letters (A, B, C, etc.) assigned to assemblies are referred to in the "Used In" column to identify which components belong to an assembly. The item numbers (1, 2, 3, etc.) assigned to components relate the parts list to the illustration.

Used In	Item	Part Number	Description	Comments
			ASSEMBLIES	
A	D33 02850	93000Z	DRIVE CHART=3022V7 VSP 50CYC	30015V7J & 30022V6J 50 CYCLE
B	D33 02860	93000Z	DRIVE CHART=3022V7 VSP 60CYC	30015V7J & 30022V6J 60 CYCLE
			COMPONENTS	
all	1	561825B2SD	VPUL 2B18.25 (SD) MTO	
all	2	56VB071XM2	VBELT BX71 MATCHSET2 EA=1BELT	2 BELT SET
all	3	56Q1KSD	1+1/2" BUSH VPUL QD TYPE SD	
all	4	56Q30B2H	VPUL 2B3.0/A2.6 2BK32H R EQUAL	
all	5	56Q1CH	1+1/8" BUSH VPUL TYP H,D,OR QT	

Motor Mount

30015, 30022, 36026, 42026, & 42030Vxx,Txx



Pellerin Milnor Corporation
P. O. Box 400, Kenner, LA 70063-0400

BMP000008/2010104B
(Sheet 1 of 2)

Litho in U.S.A.

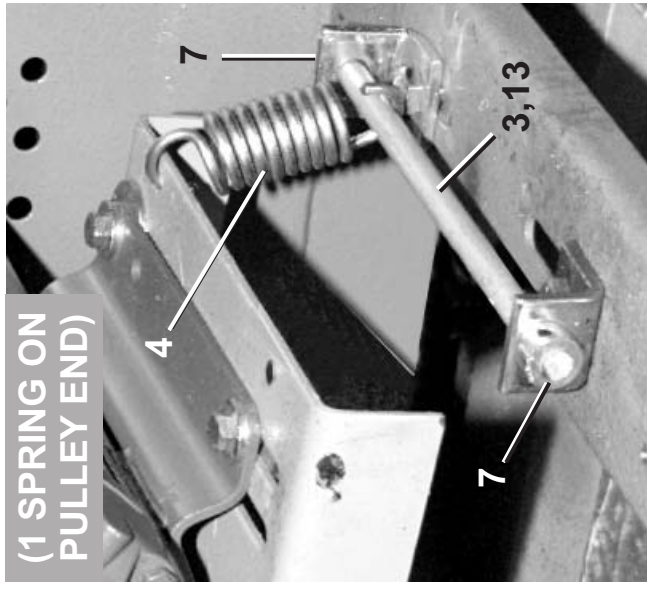
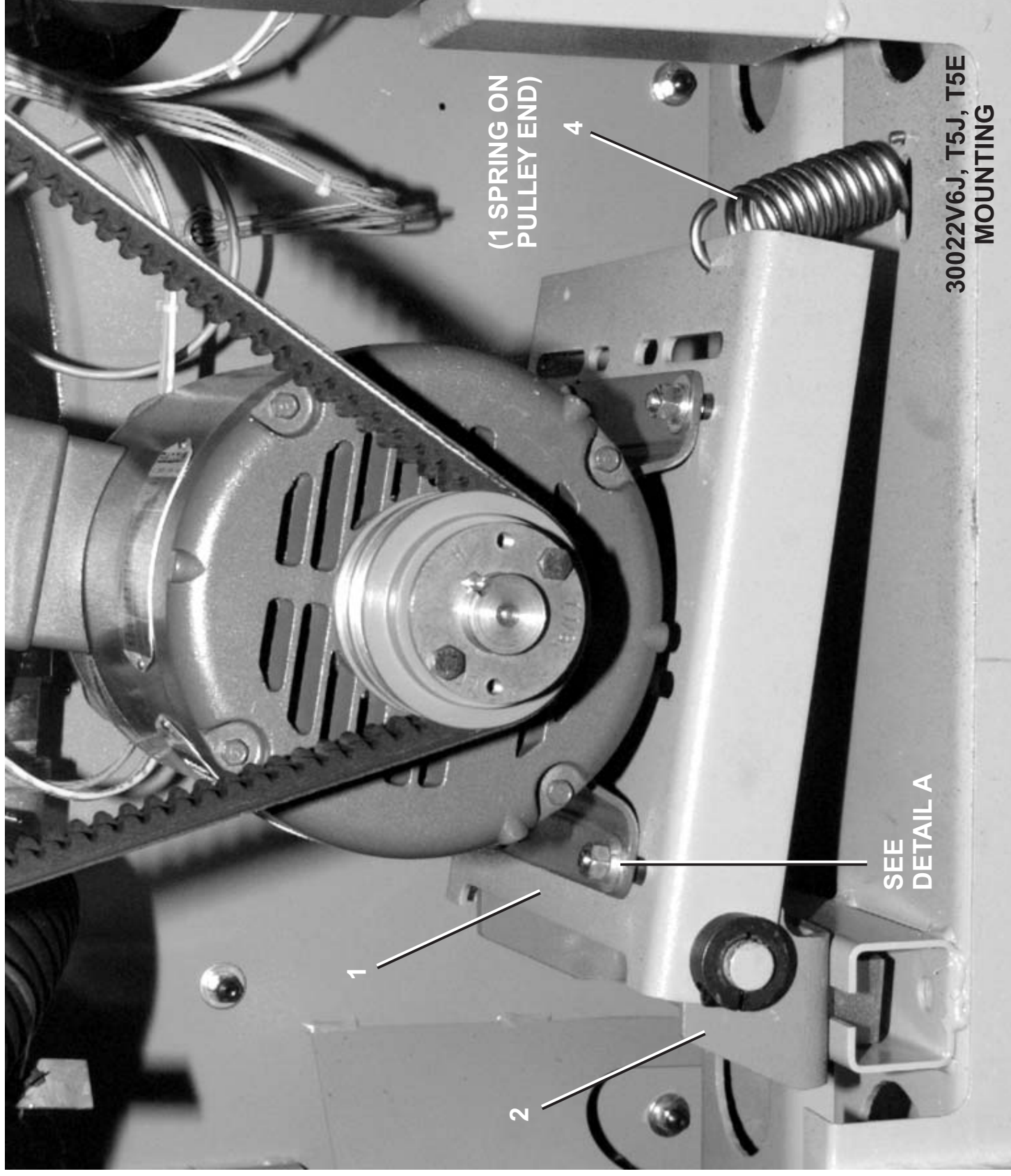
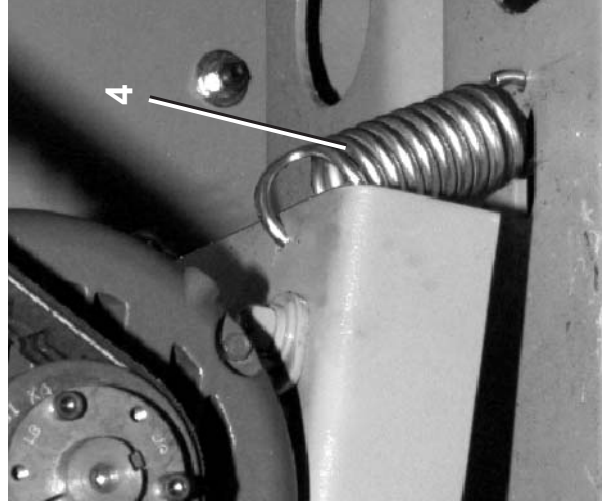
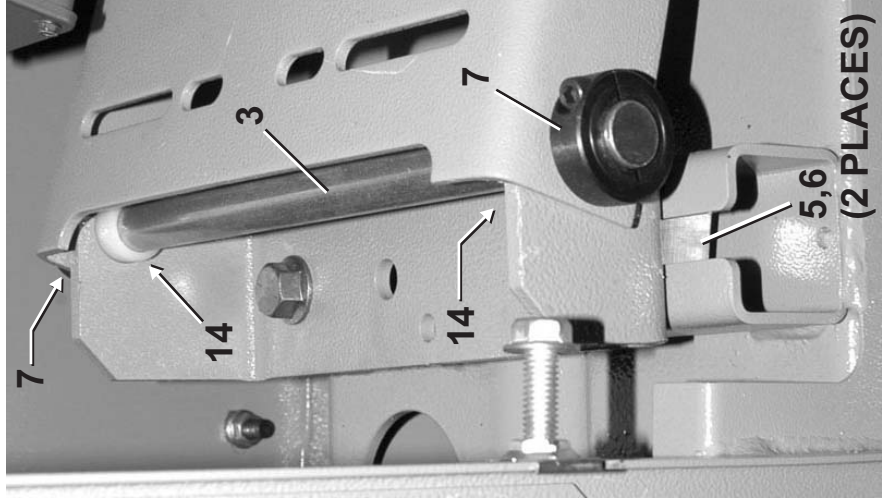

36026V5J/V7J, 42026V6J, &
42030V6J MOUNTING
(ITEM 13, TUBE, SLIDES
OVER SHAFT TO
TIGHTEN BELT)

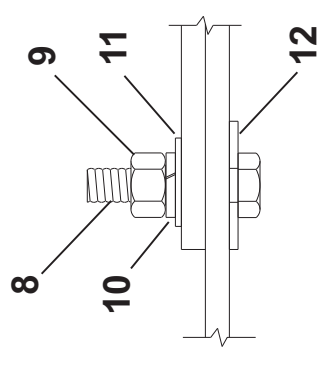

DETAIL A
(4 PLACES)



Pellerin Milnor Corporation
P. O. Box 400, Kenner, LA 70063-0400

Litho in U.S.A.

Parts List—Motor Mount

Find the correct assembly first, then find the needed components. The item letters (A, B, C, etc.) assigned to assemblies are referred to in the "Used In" column to identify which components belong to an assembly. The item numbers (1, 2, 3, etc.) assigned to components relate the parts list to the illustration.

Used In	Item	Part Number	Description	Comments
-----ASSEMBLIES-----				
	A	ADB3022S4	ASSY=DRIVE BASE, 3022S4	3015V7J,T5J,T5E 3022V6J,T5J,T5E 3626V5J,V7J,4226V6J
	B	ADB12001	DRIVE ASSY 4230V	4230V6J
-----COMPONENTS-----				
all	1	02 04256	PLATE=MOTOR MNT, 3022S4	
all	2	02 04257	BRKT=MOTOR MOUNT, 36V7/42V6	
all	3	02 04258	SHAFT=MOTOR MOUNT, 3022S4	
all	4	02 04259	SPRNG/MOT MOUNT/3022S4#SPC2690	
all	5	02 19283	NUT=1/2-13UNCX1+1/2SQ SPEC	
all	6	15K162	HXCAPSCR 1/2-13UNC2AX1.5 GR5 P	
all	7	54JH10750C	SHFTCOLLAR 3/4"CLPTYP(SGLSPLT)	
all	8	15K095	HXCPSCR 3/8-16UNC2AX1 GR5 ZINC	
all	9	15G205	HXNUT 3/8-16UNC2B ZINC GR2	
all	10	15U255	LOCKWASHER MEDIUM 3/8 ZINCPL	
all	11	15U240	FLATWASHER(USS STD) 3/8" ZNC P	
all	12	15U241	FLATWASHER 13/32IDX1+3/4ODX14G	
all	13	02 04258B	TUBE=MOTOR MOUNT SPRING ADJ	
all	14	54E226	FLBRNYL 3/4"X1"X1";EA=1 FLGBRG	

Section
Bearing Assemblies

3

Cylinder, Shell, Bearing, and Console Installation

30015V7J,T5E,T5X; 30022V6J,T5J,T5E,T5X

BMP910037/2010353B
(Sheet 1 of 2)



Pellerin Milnor Corporation
P. O. Box 400, Kenner, LA 70063-0400

Litho in U.S.A.

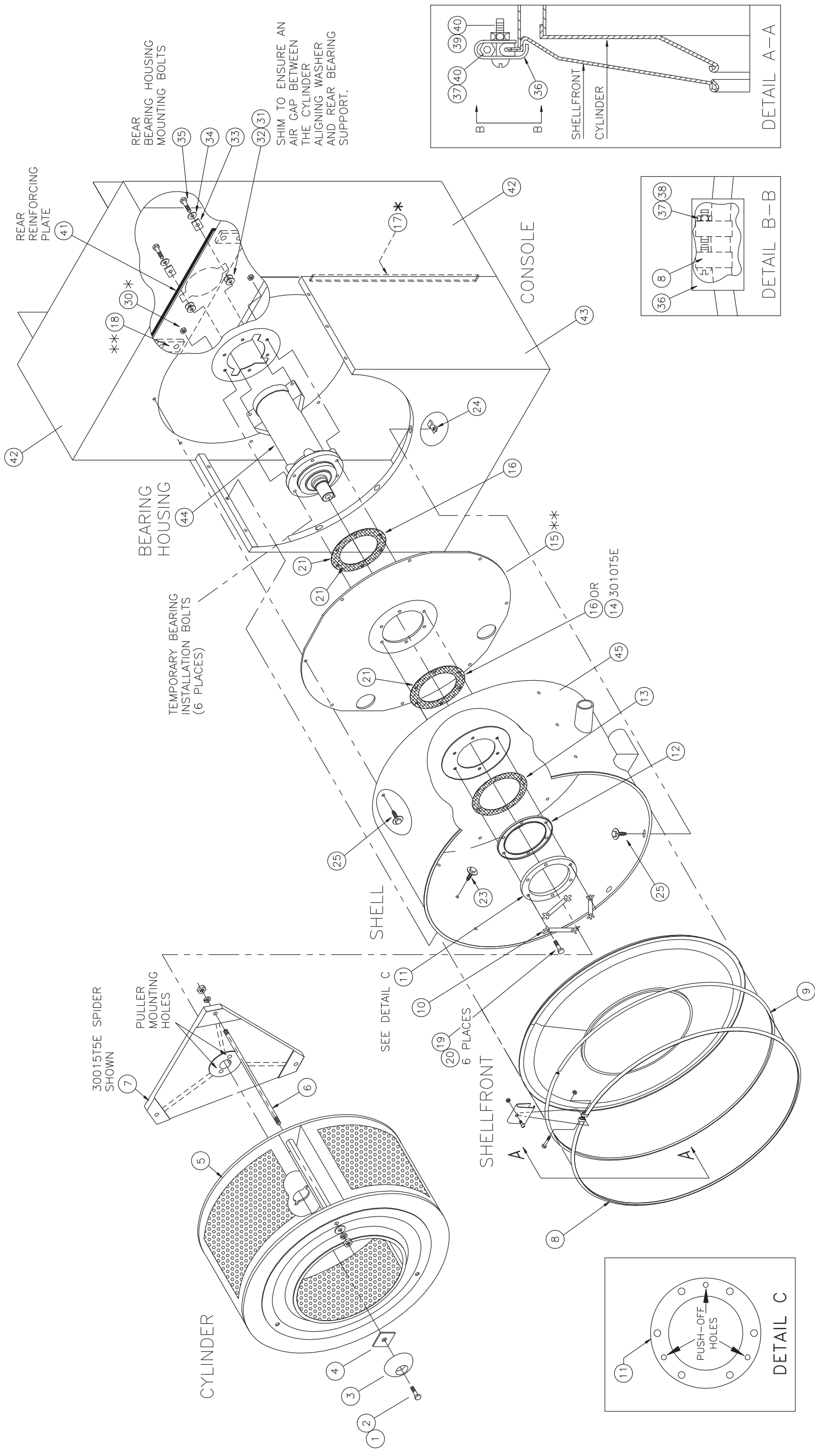



Pellerin Milnor Corporation
P. O. Box 400, Kenner, LA 70063-0400

Litho in U.S.A.

Parts List—Cylinder, Shell, Bearing, Console Installation
Find the correct assembly first, then find the needed components. The item letters (A, B, C, etc.) assigned to assemblies are referred to in the "Used In" column to identify which components belong to an assembly. The item numbers (1, 2, 3, etc.) assigned to components relate the parts list to the illustration.

Used In	Item	Part Number	Description	Comments
			ASSEMBLIES	
	A	ASH33040A	SHELL+CONSOLE 3015V7	30015V7J
	B	GSC30005	3015T5 FRNT/REAR CNSLE INSTALL	30015T5E/T5X
	C	ASH3022A	3022 SHELL+CONSOLE ASSY	30022V6J/T5J
	D	GSC30004	3022T5 FRONT/REAR CNSL INSTALL	3022T5E/T5X
			COMPONENTS	
all	1	15B200	HEXCAPSCR 3/4-10X1+3/4 SS18-8	
all	2	15U350	LOCKWASHER 3/4 MED SS18-8	
all	3	02 11196	COVER=SHAFT RETAINER=304S/S	
all	4	02 14359	SPACER SHT RETNR-LG 3" OUR MATL	
BD	4	02 14359A	SHAFT RETNR SPACER 2+3/4" SQ	
A	5	ACA33C6M	CYL ASSY=3015C6M	
B	5	ACA02CWE	CYL ASSY=3015CWE/NMA/C4M/OE	
CD	5	ACA3022M5	CYL ASSY=3022 M5/C/K/S	
AB	6	02 02138A	CYLTIEROD-3/3015W+CWJ 18-8SS	PART OF 5A & 5B
CD	6	02 03703J	CYLINDER TIE ROD 3022S5	PART OF 5C
A	7	X2 03561	SPIDER=C6M ONLY-CASTIRON	PART OF 5A
B	7	X2 02758	SPIDER=1/CWU+25W	PART OF 5B
CDI	7	X2 03561A	SPIDER C5M	PART OF 5CD
all	8	Y2 02059	*SHELL CLAMP RING=30" MACHINE	
all	9	02 02087C	EXTRUS*ION-SHELL=30"MACHINES (
all	10	02 03629	LOCKSTRAP=BEAR HOUS S/S	
ACD	11	X2 03576	RING=SHELL BACK CLAMP=1/C6M	
B	12	02 03444	RING=SHELL BACK CLAMP	
B	13	02 03446	GASKET=SHELLBACK CLAMPRING	
ACD	13	02 03575	GASKET=SHELLBAKCLAMPRING=CWM	
B	14	02 03335	GASKET=MAIN BEARINGHOUSE=CWM	
CD	15	02 03568	PLATE-BG HOUSING REINFORCING	
All	16	02 03574	GASKET=MAIN BEARINGHOUSE=CWM	
B	17	02 03749	BAR=REINF STRIP 3015	
ACD	18	02 03560	TAPSTRIP=BEARING SUPPORT	
AB	19	15K126	HEXCAPSCR 3/8-16NCX2+1/2SS18-8	
CD	19	15K196	HEXCAPSCR 1/2-13UNCX3 18-8SS	
all	20	20C013C	GSKT ELIM.250CC LCT#504-41	
all	21	20C036A	PERMATEX NO 2C IN 11 OZ TUBES	
All	23	15B101A	3/8-16UNC X 3/4 WPLASTISOL SS	

Used In	Item	Part Number	Description	Comments
all	24	17N071	NUT J-TYP #C33896-3816-3B 3/8"	
all	25	15B102	3/8-16X1 UNSLTINDHEXTYF SS	
AB	30	15G218	HXLKNUIT NYL 3/8-16 STL/ZNC	
all	31	15U245	FLTWASH 3/8 STD COMM 18-8 SS	
all	32	15U312	FLAWASHER 3/4ODX33/64IDX11GA Z	
all	33	02 03397	CYLINDER ALIGNING WASHER	
all	34	15U300	LOKWASHER REGULAR 1/2 ZINC PLT	
all	35	15K182	HEXTAPSCR 1/2-13XZINC GR5 FUL	
all	36	02 02181	GUARD=SHELL MOUNT RING CLIP	
all	37	15N200	FILMACSCR 1/4-20UNCX2 SS18-8 S	
all	38	15G170	HEXNUT 1/4-20UNC2 SS18-8	
all	39	15G130	HEXMACHSCRNUT 10-24UNC2 SS18-8	
all	40	15N146	RDMACHSCR 10-24UNC2X1 SS18-8	
ACD	41	02 03559	SUPPORT=REAR BRG HOUSE	
ACD	42	W2 03770C	WLMT=REAR CNSL,3022V5 REAR H20	
B	42	W2 03770D	WMT=REAR CNSL,3015TX REAR H20	
AB	43	W2 03698Q	WLMT=FRNT CNSLE EMBOSS 3015	
CD	43	W2 03698W	WLMT=FRNT CNSLE EMBOSS 3020	
A	44	SA 33 048	MAIN BEARING ASSY 3015C6M	
B	44	SA 33 030	MAIN BRG ASSY 3015CWE+NMA+C4	
CD	44	A33 09901	MAIN BEARING ASSY=C5M + N4M	
A	45	ASH33016A	ASSY=SHLL&DRN 3015M6 REAR H20	
B	45	ASH33016B	ASSY=SHLL&DRN 3015T5E REAR H20	
C	45	ASH33011B	ASSY=SHLL+DRAIN 3022VT	
D	45	ASH33011D	ASSY=SHLL+DRAIN 3022 TIMER	

Main Bearing Assembly 30015V7J, T5J, T5E

BMP910034/2010065B
(Sheet 1 of 2)



Pellerin Milnor Corporation
P. O. Box 400, Kenner, LA 70063-0400

Litho in U.S.A.

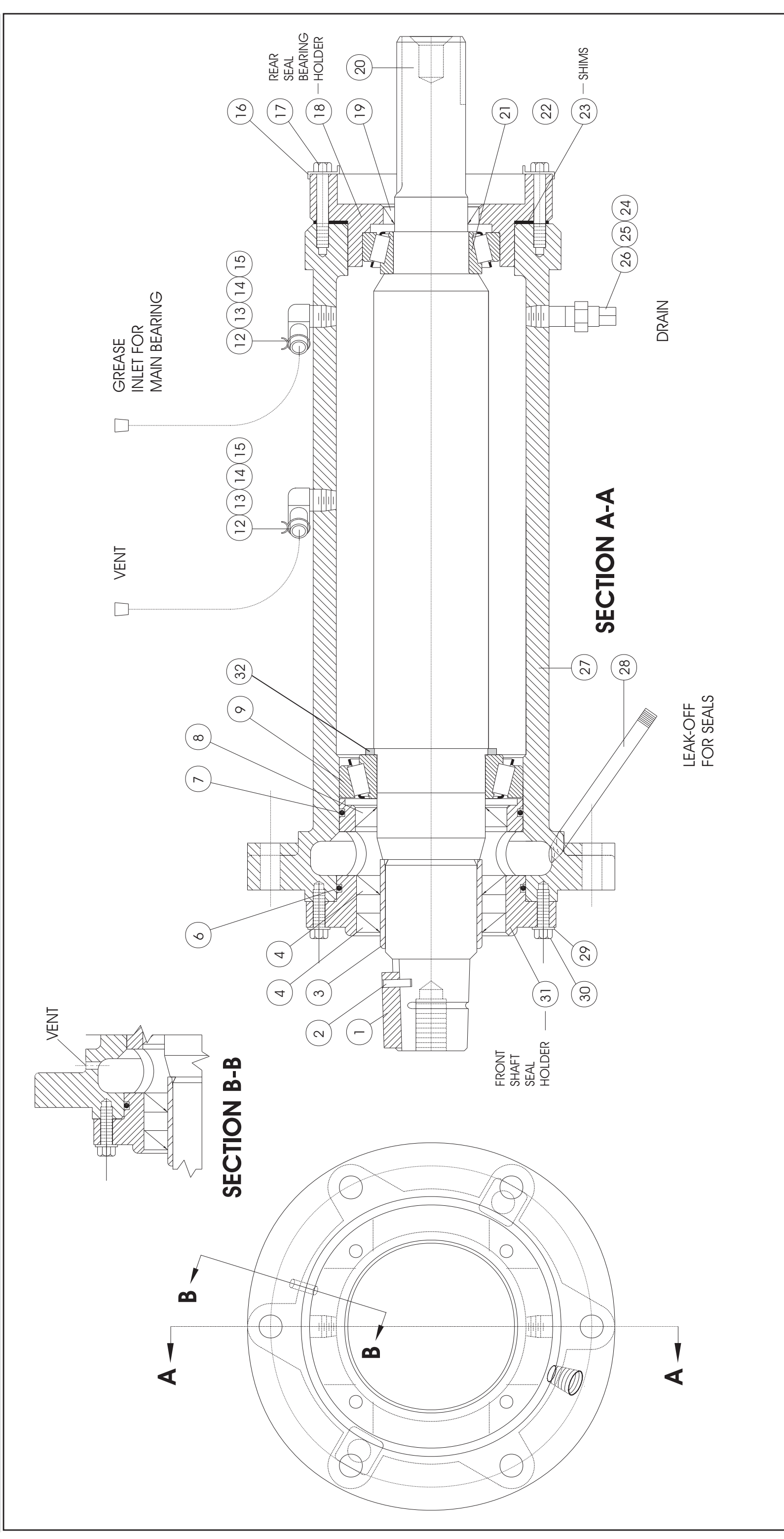



Pellerin Milnor Corporation
P. O. Box 400, Kenner, LA 70063-0400

Litho in U.S.A.

Parts List—Main Bearing Assembly

Find the correct assembly first, then find the needed components. The item letters (A, B, C, etc.) assigned to assemblies are referred to in the "Used In" column to identify which components belong to an assembly. The item numbers (1, 2, 3, etc.) assigned to components relate the parts list to the illustration.

Used In	Item	Part Number	Description	Comments
			-----ASSEMBLIES-----	
	A	SA 33 048	* BEARING ASSY 3015C6M ONLY	30015V6J, T5J,T5E
			-----COMPONENTS-----	
all	1	02 02294A	SHAFT KEY 3/8 X 3/8	
all	2	15H089S	SPRINGPIN 1/8"DIA X 5/8" LONG	
all	3	02 03311	SEAL SLEEVE OUR MATL	
all	4	24S005	SEAL 2.25 X 3.0 X .375 SS BUNA	
all	5	24S005	SEAL 2.25 X 3.0 X .375 SS BUNA	
all	6	60C151	ORING 3+7/8ID1/8CS BUNA70#241	
all	7	60C150	ORING 3+3/4ID1/8CS BUNA70 #240	
all	8	24S015	SEAL 2.265X3.256X.433 CR#23678	
all	9	54A319320	TIM28920 2-24/28985 2-51=2.375	
all	12	5SL0EBEC	NPTELB 90DEG STRT 1/4 BRASS125	
all	13	03 01142	NIPPLE 1/4X1+1/4 BRASS	
all	14	27A043A	HOSECLAMP.562"DIA.SPRG#HC9STZD	
all	15	60E005P	PVC TUBING 1/2"ID X 5/8"OD	
all	16	15U152A	FLTWSHR .680OD,.375ID,.0625T	
all	17	15K121A	HXCPCS 3/8-16X2 GR8 ZC	
all	18	X2 03659A	HOUSE=SEAL+BRG 30M,V7	
all	19	24S048AAA	SEAL 1.625X2.375X.375 CS/BUNA	
all	20	X2 03314A	MAIN SHAFT=3015N6E+C6M	
all	21	54A307308	TIM M802011 2-24/M802048=1.625	
all	23	02 03323A	SHIM=.005 CRS BLUE	AS REQUIRED
all	23	02 03323B	SHIM=.010 CRS RED	AS REQUIRED
all	23	02 03323C	SHIM=.0075 CRS BLACK	AS REQUIRED
all	23	02 03323D	SHIM=.020 CRS WHITE	AS REQUIRED
all	23	02 03323E	SHIM=.050 CRS CLEAR	AS REQUIRED
all	24	5SP0EFFSSM	NPT PLUG 1/4 SQSLDMAGNET BLKST	
all	25	5N0E01KBE2	NPT NIP 1/4X1.5TBE BRASS STD.	
all	26	5SCC0EBE	NPT COUP 1/4 BRASS 125# W/HEX	
all	27	X2 03573	BEARHOUSE=C6M ONLY	
all	28	5N0E05AG42	NPT NIP 1/4X5 TBE GALSTL SK40	
all	29	02 03564	BOLT LOCKING TAB 1/4 BOLT	
all	30	15K062	HEXCAPSCR 5/16-18X1 18-8SS	
All	31	X2 03437	HOLDER=SHAFT SEAL=1/CWU	

Main Bearing Assembly

30022V6J,T5E,T5X,C4E

BMP910033/2010065B
(Sheet 1 of 2)



Pellerin Milnor Corporation
P. O. Box 400, Kenner, LA 70063-0400

Litho in U.S.A.

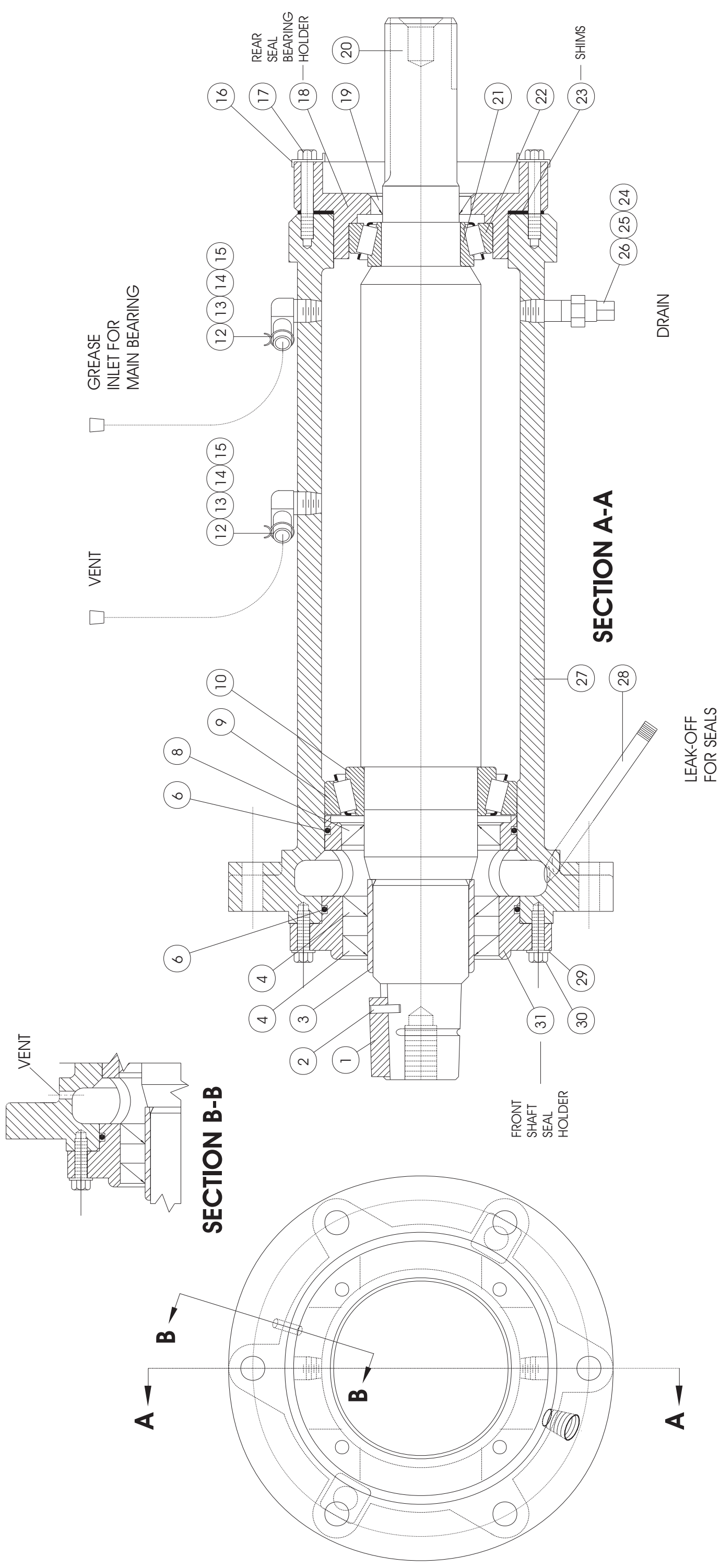



Pellerin Milnor Corporation
P. O. Box 400, Kenner, LA 70063-0400

Litho in U.S.A.

Parts List—Main Bearing
Find the correct assembly first, then find the needed components. The item letters (A, B, C, etc.) assigned to assemblies are referred to in the "Used In" column to identify which components belong to an assembly. The item numbers (1, 2, 3, etc.) assigned to components relate the parts list to the illustration.

Used In		Item	Part Number	Description	Comments
	A		A33 09901	* BEARING ASSY=C5M + N4M	3022V6J,T5E,T5X,C4E
				-----ASSEMBLIES-----	
				-----COMPONENTS-----	
all		1	15H089S	SPRINGPIN 1/8"DIA X 5/8" LONG	
all		2	02 02294A	SHAFT KEY 3/8 X 3/8	
all		3	02 13143	SEALSLEEVE=SWE-1/SWE	
all		4	24S053	SEAL 2.625X3.625X.437#10050LUP	
all		5	24S053	SEAL 2.625X3.625X.437#10050LUP	
all		6	60C151	ORING 3+7/8ID1/8CS BUNA70#241	
all		7	60C151	ORING 3+7/8ID1/8CS BUNA70#241	
all		8	24S052A	SEAL 2.559X3.55X.315 CR#25430	
all		9	54A916	CUP TIMKN#JLM710910 1/BX+PT#	
all		10	54A915	CONE TIMKN#JLM710949C 1/BX	
all		12	5SLOEBEC	NPTELB 90DEG STRT 1/4 BRASS125	
all		13	03 01142	NIPPLE 1/4X1+1/4 BRASS	
all		14	27A043A	HOSECLAMP.562"DIA.SPRG#HC9STZD	
all		15	60E005P	PVC TUBING 1/2"ID X 5/8"OD	
all		16	15U152A	FLTWSHR .680OD,.375ID,.0625T	
all		17	15K121A	HXCPSC 3/8-16X2 GR8 ZC	
all		18	X2 03659A	HOUSE=SEAL+BRG 30M,V7	
all		19	24S048AAA	SEAL 1.625X2.375X.375 CS/BUNA	
all		20	X2 13103A	SHAFT,MAIN FOR 3020C5M+N4M	
all		21	54A308	CONE M802048 TIM 2-24 1/BX+PT#	
all		22	54A307	CUP M802011 TIMK 2-24 1/BX+PT#	
all		23	02 03323	SHIM=.003 CRS GREEN	AS REQUIRED
all		23	02 03323A	SHIM=.005 CRS BLUE	AS REQUIRED
all		23	02 03323B	SHIM=.010 CRS RED	AS REQUIRED
all		23	02 03323C	SHIM=.0075 CRS BLACK	AS REQUIRED
All		23	02 03323D	SHIM=.020 CRS WHITE	AS REQUIRED
all		23	02 03323E	SHIM=.050 CRS CLEAR	AS REQUIRED
all		24	5SP0EFFSSM	NPT PLUG 1/4 SQSLDMAGNET BLKST	
all		25	5N0E01KBE2	NPT NIP 1/4X1.5TBE BRASS STD.	

Parts List, cont.—Main Bearing

Used In	Item	Part Number	Description	Comments
all	26	5SCC0EBE	NPT COUP 1/4 BRASS 125# W/HEX	
all	27	X2 03573A	HOUSING BEARING C5M	
all	28	5N0E05AG42	NPT NIP 1/4X5 TBE GALSTL SK40	
all	29	02 03564	BOLT LOCKING TAB 1/4 BOLT	
all	30	15K062	HEXCAPSCR 5/16-18X1 18-8SS	
all	31	X2 13144A	HOLDER=SHFT SEAL(05=24S052A)	

Section

4

Shell and Door Assemblies

Shellfront Assembly, Conduit, & Interlock

3010 / 3015 G5E,G5X,CGE

30015 V7J,T5J,C4A,C4E & 30022 V6J,T5J,C4A,C4E

BMP920024/2004055V
(Sheet 1 of 2)



Pellerin Milnor Corporation
P. O. Box 400, Kenner, LA 70063-0400

Litho in U.S.A.

FOR DOOR ASSEMBLY, SEE BMP920009.

FOR INTERLOCK ASSEMBLY, SEE BMP750046.

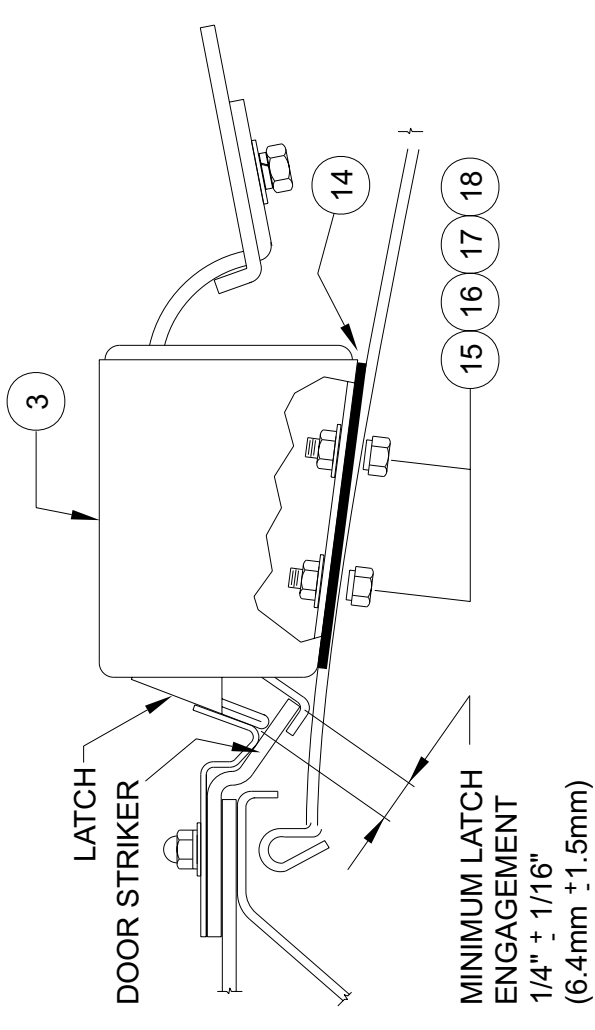
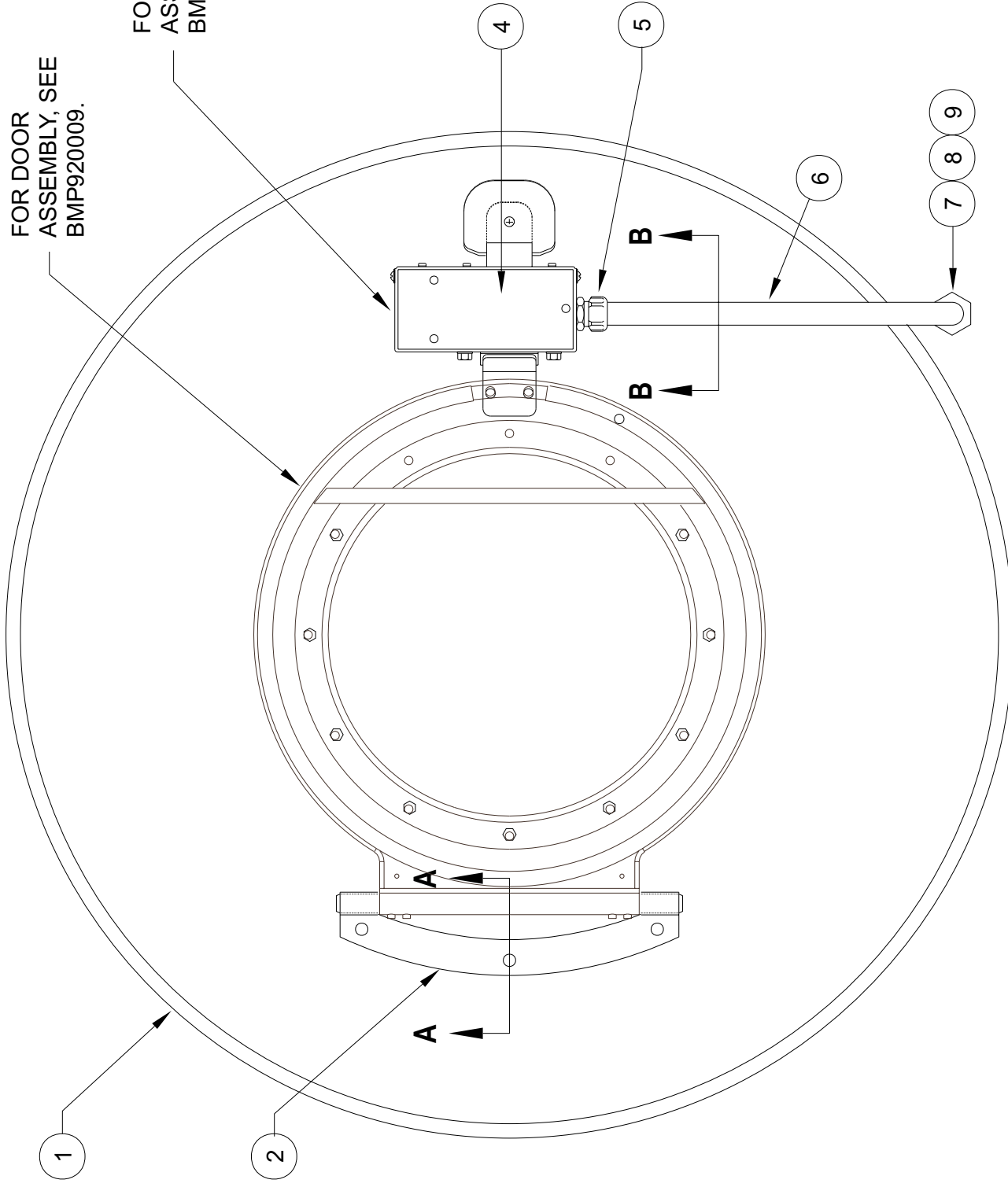

VIEW "B-B"

ADJUSTMENTS:

1. ADJUST DOOR STRIKER SO THAT IT TOUCHES THE LATCH SQUARELY AND EVENLY.
2. ADJUST THE LATCH SO THAT THE MINIMUM ENGAGEMENT WITH THE DOOR FULLY CLOSED EQUALS 1/4" ± 1/16" (6.4mm ± 1.5mm).

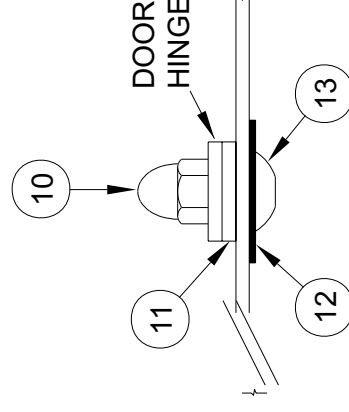

VIEW "A-A"



Pellerin Milnor Corporation
P. O. Box 400, Kenner, LA 70063-0400

Litho in U.S.A.

Used In		Item	Part Number	Description	Comments
<p>Parts List—Shellfront, Conduit & Interlock Find the correct assembly first, then find the needed components. The item letters (A, B, C, etc.) assigned to assemblies are referred to in the "Used In" column to identify which components belong to an assembly. The item numbers (1, 2, 3, etc.) assigned to components relate the parts list to the illustration.</p>					
<p>-----ASSEMBLIES-----</p>					
A		A33 10100C		*SHLASSY (IDNT) UNLOK N4P	3015M4G/J/P, M6J,D4A 3022M5G/J
B		A33 10100H		SHELL FRONT ASSY 3015/20M4A	3015M4A, C4T, M4T, M6A, M6T 3022M5T, 3022C4T
C		A33 10100M		SHLASSY N/LOCK 3015/22S#G/J	3022S4J, S4G, S5J 3015K4A, S4J, S5G, S5J
D		A33 10100N		SHLASSY N/LOCK 3015/22V/T	3010G5E, G5X 3015G5E, G5X, V7J, T5E, T5J, T5X 3022V6J, T5E, T5J, T5X
E		A33 10100F		*SHLASSY (IDNT) UNLOK C4A	3015C4A, 3022C4A
F		A33 10100G		SHLFR TASY N/O ILOK W/PROX	3010CGE, 3015CGE, 30015C4E 30022C4E
<p>-----COMPONENTS-----</p>					
ABCDE	1	X2 02361B		SHELLFRONT, 30" ELECTRIC LOCK	
F	1	X2 02361C		2002296D SHELLFR T=30" ILOC W/PROX	
A,C,D	2	A33 07100C		*DRASSY (INDNT) LK, LOGO N4, 5, 6P	
B	2	A33 07100H		95027 DOOR ASY 3015/3020M4A	
EF	2	A33 07100F		95027# DRASSY (INDNT) LK, LOGO C4A	
A,B	3	EDL00171		INTRLKHSG ASSY=N/UNLOCK 240V	
C	3	EDL00371		INTERLKHSG=N/LOCK+SWITCH240V	
D	3	EDL00271		INTRLKHSG ASSY=N/LOCK 220V	
F	3	EDL00171C		INTRLKHSG ASSY=N/O W/ PROX 240	
all	4	01 10422		NPLATE: DOOR ILOC->N4, 5, 6 P	
all	5	12K040		1/2" COND. EMT COND. PECO #260B	
All	6	03 01446		1/2 EMT CONDUIT 900D=DR INTR	
all	7	10Y71M4GEX		*M4G EXTERNAL CONNECTIONS	
all	8	12K040		1/2" COND. EMT COND. PECO #260B	
all	9	12P1ASSB		SNAPBUSH 7/8" MH X 11/16	
all	10	15G200C		HXCPNUT HI 3/8-16 BRASS NIK PL	
all	11	02 02819C		SPACER-SHELLFRONT/HINGE	
all	12	02 02293		DOOR HANDLE NUT GASKET	
all	13	15K084		TRUSS HXSOK 3/8-16 X 23/32SS	
ABCDE	14	02 03669		GASKET=INTRLK HOUSING	
F	14	02 03669C		GASKET=INTRLK HOUSING 8" LONG	
all	15	15N174		HXCAPSCR 1/4-20UNC2X5/8SS18-8	
all	16	15U180		LOCKWASHER MEDIUM 1/4 ZINCPL	
all	17	24G020N		ROLLED WASH. 252ID NYLTITE 25W	

Used In		Item	Part Number	Description	Comments
All		18	15G168	SQ NUT 1/4-20UNC2 SS18-8	

Door Assembly
30015 & 30022 Rigid Mount



Pellerin Milnor Corporation
 P. O. Box 400, Kenner, LA 70063-0400

BMP920009/2008232B
 (Sheet 1 of 2)

Litho in U.S.A.

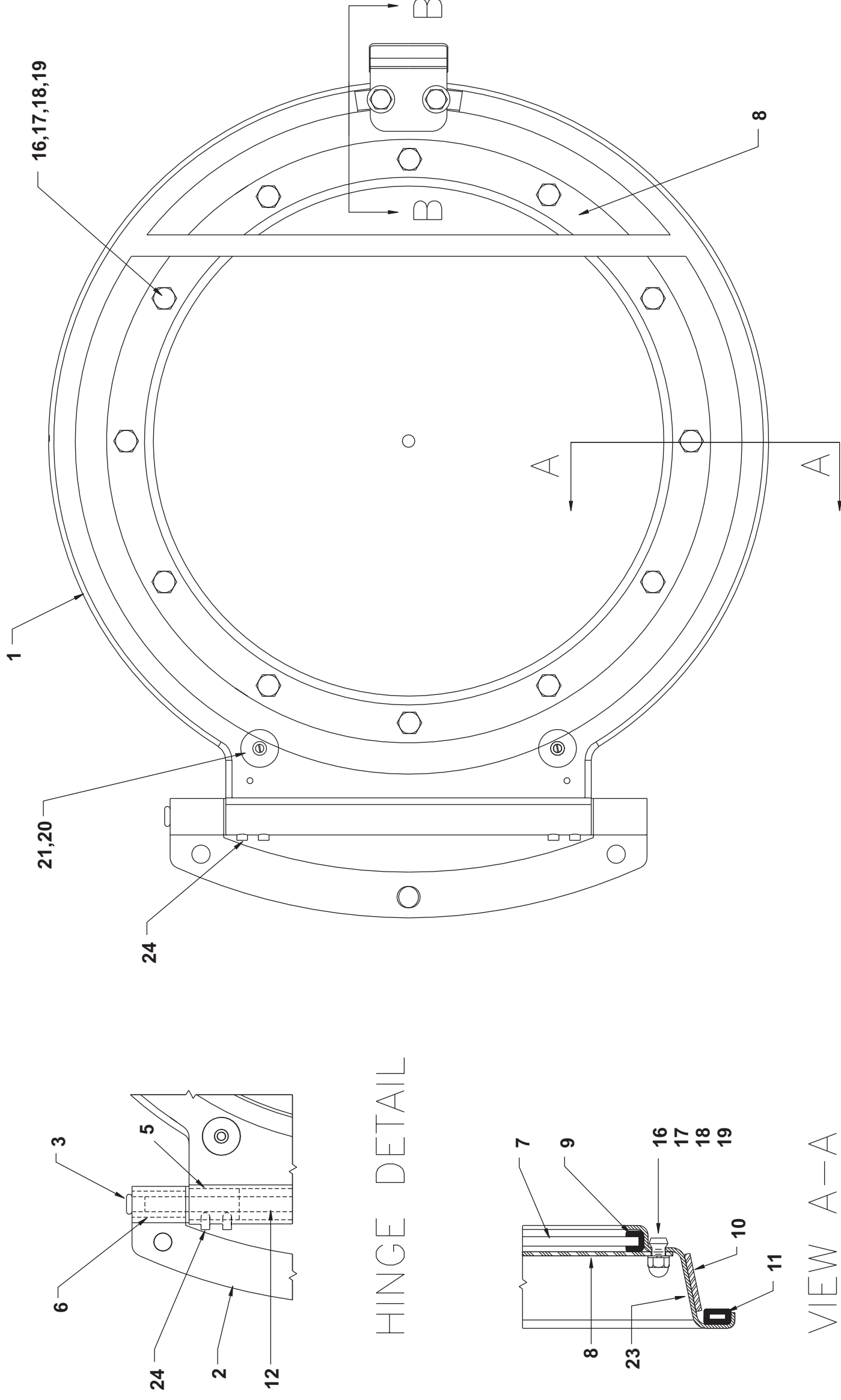



Pellerin Milnor Corporation
P. O. Box 400, Kenner, LA 70063-0400

Litho in U.S.A.

Parts List—Door Assembly

Find the correct assembly first, then find the needed components. The item letters (A, B, C, etc.) assigned to assemblies are referred to in the "Used In" column to identify which components belong to an assembly. The item numbers (1, 2, 3, etc.) assigned to components relate the parts list to the illustration.

Used In	Item	Part Number	Description	Comments
-----ASSEMBLIES-----				
	A	A33 07100C	*DRASSY(INDNT)LK,LOGO N4,5,6P	30015V7J,T5J,T5E 3022V6J,T5J,T5E 3015V7G/V7J;3022V7G/V7J 3015M4G/J/P,M6J,D4A 3022M5G/J 3022S4J,S4G,S5J 3015K4A,S4J,S5G,S5J
	B	A33 07100H	DOOR ASY 3015/3020M4A	30015M4A+30020M4A ONLY
	C	A33 06900F	ASSY=DOOR W/MLOGO DKRED 3022	3022F8J/F8P/F8W
-----COMPONENTS-----				
all	1	X2 02814F	MACH=SHELLDOOR DRAWN, 30XX	
all	2	02 02819	HINGE=STAMPED DOOR 25#	
all	3	12P1AGHP1	HOLEPLUG 3/8"BLACK LPE	
all	5	02 02815	PLAIN BRG=DOOR HINGE-NYLON	
all	6	02 02817	FLANGE BRG=DOOR HINGE-NYLON	
A,C	7	02 09215	DRGLASS 12 3/8DIA SS STAMPED	
B	7	02 09215A	DORGLAS=DRAW W/MILNOR LOGO	
all	8	02 09021	RING=DOOR GLASS PRESSURE	
all	9	02 02366	GASKET DOORGLAS GTR52-5220-3	
all	10	02 10545	EXTR BAND-STAMPED SS CYLDOOR	
all	11	02 10342G	GASKET 15" DOOR-BLACK	
all	12	02 02764	HINGEPIN=SHELLDOOR L=10+5/8"	
all	13	03 01420	PLATE=DOOR STRIKER=ILOC	
all	16	15G140	HXCPNT 1/4-20 #C250=20 NKLPLT	
all	17	15K031	BUTSOKCAPSCR 1/4-20X1/2 SS18-8	
all	18	15U181	LOCKWASHER MEDIUM 1/4 SS18-8	
all	19	24G020N	ROLLED WASH.252ID NYLTITE 25W	
all	20	60C080	RECESS BUMPER RUBBERLAVELLE #7	
all	21	15P103	TRDCUT-F RDHDSLOT 8-32UNCX1/2	
all	22	15N173A	FLTMACSCR 1/4-20 UNCX5/8 UCUTS	
all	23	20C018	ADHESIVE-3M #1357-QT CN	
all	24	15Q077	SOKSETSCR 1/4-20X1/4 ZINC ALLE	
all	25	03 01423J	LATCH GUARD ILOC	
A,B	26	02 11904K	SHIM=DOOR HANDLE=4226RWP	
all	35	15U188	FLTWASH 1/4 STD COMM SS18-8	
all	36	15N163A	FLTMACSCR 1/4-20UNCX 1/2 UCUTS	

Interlock Assembly

BMP750046/2007513B
(Sheet 1 of 2)



Pellerin Milnor Corporation
P. O. Box 400, Kenner, LA 70063-0400

Litho in U.S.A.

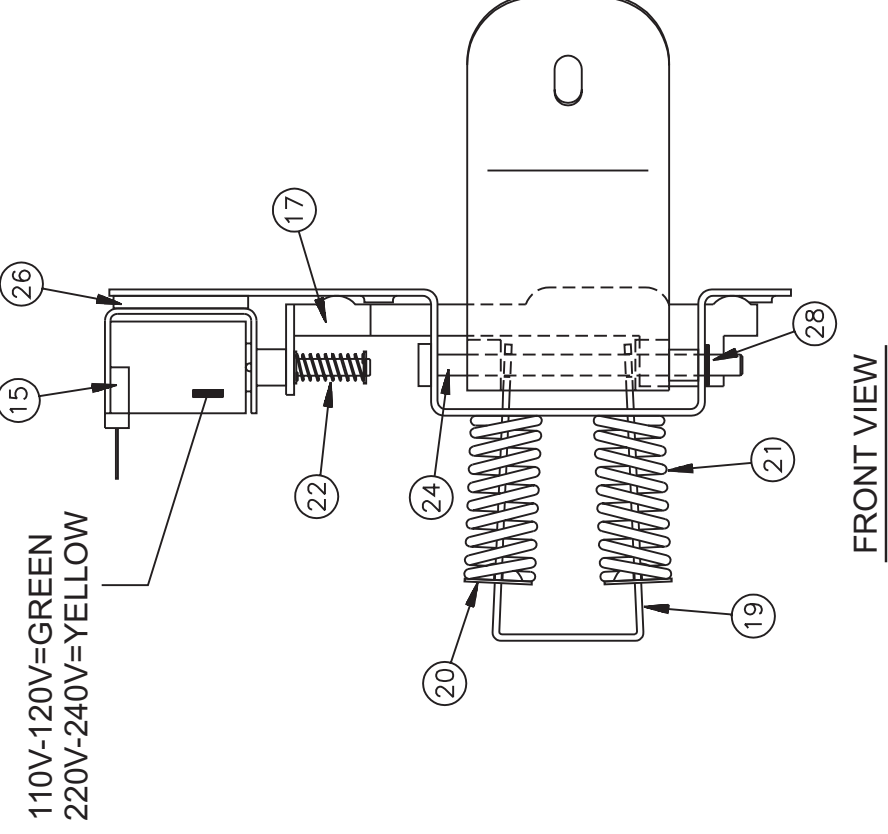
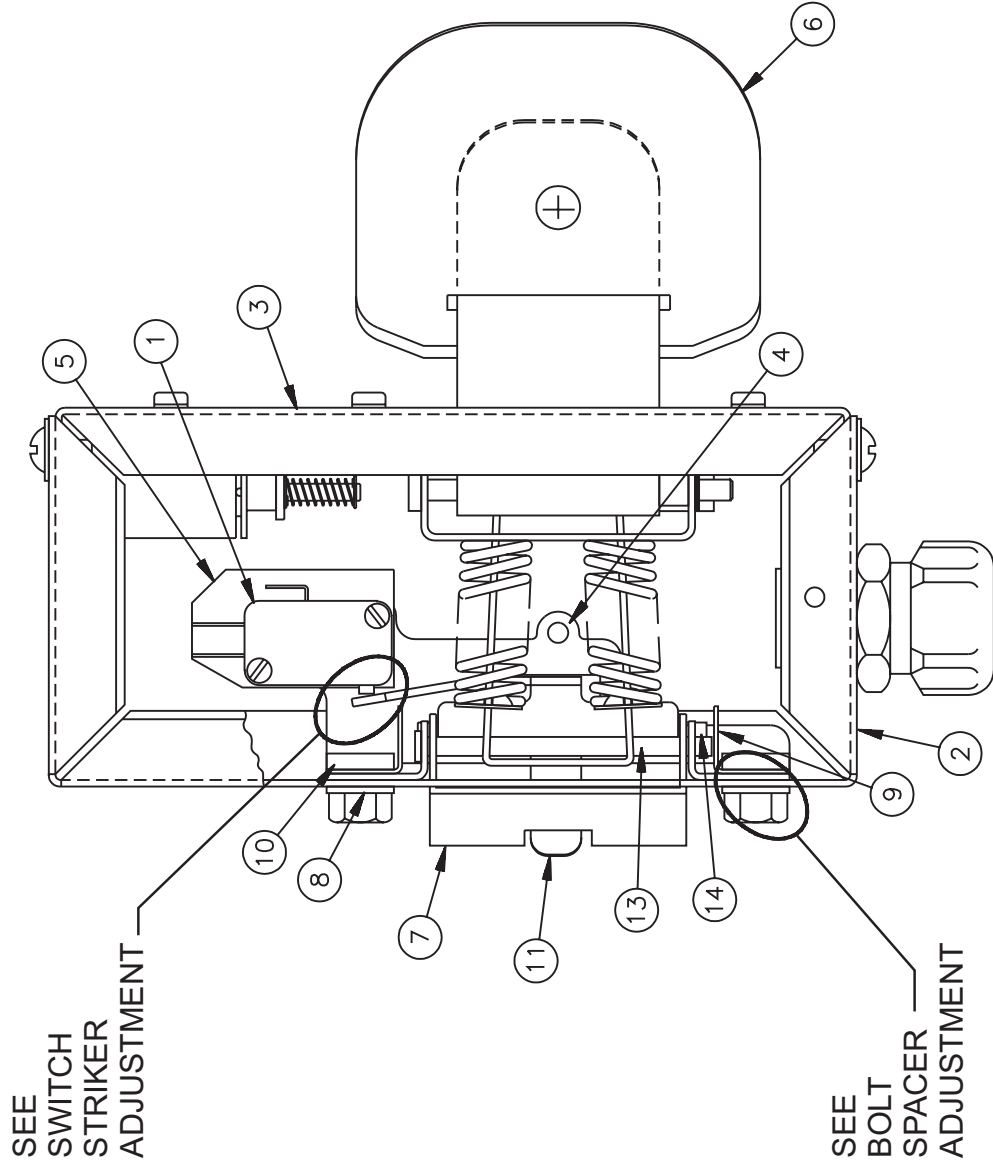

ASSEMBLIES 00AA,00BB,00CC,00DD

SWITCH STRIKER ADJUSTMENT

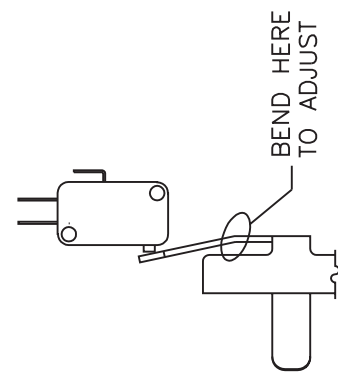

Adjust the switch striker arm by bending as shown so that :

- 1) The switch is activated when the door is closed
- 2) The switch does not actuate when the unlatching lever is fully depressed with the door open
- 3) The arm does not over travel and hit the switch housing when the door is closed and the switch is actuated.

BOLT SPACER ADJUSTMENT

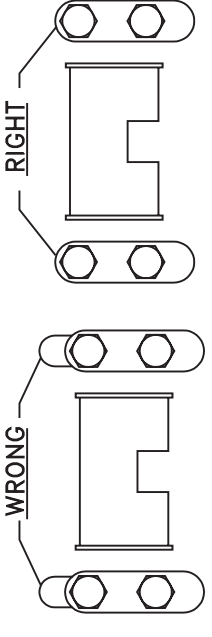

Bolt Spacer Adjustment

- 1) On a new machine the slots on the front housing should not show a gap past the bolt spacers.
- 2) The spacers should be installed with the long side toward the shellfront



Parts List—Interlock Assembly
Find the correct assembly first, then find the needed components. The item letters (A, B, C, etc.) assigned to assemblies are referred to in the "Used In" column to identify which components belong to an assembly. The item numbers (1, 2, 3, etc.) assigned to components relate the parts list to the illustration.

Used In	Item	Part Number	Description	Comments
			-----ASSEMBLIES-----	
A	EDL00171		88093# INTRLKHSG ASSY=N/UNLOCK 240V	30015V7J,T5J,T5E 3015/20/22 Mxx,Cxx,Vxx
AA	EDL00171A		93207@ RR PIVOT PL ASSY=N/UNLOCK240V	USED ON 00A (CONTAINS ITEMS 15-28)
B	EDL00221		96411 INTRLKHSG ASSY=N/LOCK 220V	3022F8J/PW 3630F8J/PW/S
BB	EDL00271A		93207#*RR PIVOT PL ASSY=N/LOCK 220V	USED ON 00B (CONTAINS ITEMS 15-28)
C	EDL00337		88093#*INTRLKHSG ASSY=N/LOCK 120V	36&42QXX,BWP 3015D4A 36021V6J, 36026V5J 36026V7J, 42026V6J 42030V6J
CC	EDL00337A		93207# RR PIVOT PL ASSY=N/LOCK 120V	USED ON 00C (CONTAINS ITEMS 15-28)
D	EDL00371		94000Z INTERLKHSG=N/LOCK+SWITCH240V	3022V6J,T5J 3022S4J,S4G,S5J 3015K4A,S4J,S5G,S5J
DD	EDL00271A		93207#*RR PIVOT PL ASSY=N/LOCK 220V	USED ON 00D & 00E (CONTAINS ITEMS 15-28)
E	EDL00271		88093#INTRLKHSG ASSY=N/LOCK 220V	30022T5E
			-----COMPONENTS-----	
all	1	09R014A	05ZMIMI-SW SPDT STAKON #V15G1C26K	
all	2	03 01426	77201D HOUSING=FRONT=ILOC	
D only	2	03 01426A	94186D HOUSING=FRONT= ILOC W/UNLATCH	
all	3	03 01427A	77181C HOUSING=REAR=ILOC (C-7)	
D only	3	03 01427B	94186D HOUSING=REAR=ILOC W/UNLATCH	
all	4	03 01429	75479C PLATE=FNT PIVOT=ILOC	
all	5	03 01335	INSULATOR=AUTOSPOT	
all	6	03 01425A	92683C DOOR HANDLE EXTENSION	
all	7	03 01423	75736B LATCH = INTERLOCK	
all	8	03 01417	75100B PLATE=SPACER=ILOC	
all	9	03 01418B	75194B KEEPER=LATCH PIN/NOTCH	
all	10	03 01418	75100B TAP STRIP=ILOC	

Parts List, cont.—Interlock Assembly

Used In	Item	Part Number	Description	Comments
all	11	03 01424A	90501B STRIKER=SWITCH=LONG TAB	
all	12	03 01442	92697B SOLENOID INSULATION=DR INTRK	(NOT SHOWN)
all	13	03 01443	84251AFLATHDRIVET 5/32X2+5/16 ZINC	
all	14	15H091	01Z STRGHTPIN 5/32"X2.25 LG ZINC	
AA,BB,DD	15	09K062B71	04Z SOLENOID 240/60--220/50 = ILOC	
CC	15	09K062B37	03Z SOLENOID(C-7)120/60--110/50	
all	16	03 01428A	93207C PLATE=REAR PIVOT=ILOC (C-7)	
AA	17	03 01421B	93207B SLIDE=NORMALLY OPEN(C7 SOL)	
BB,DD	17	03 01421A	75736B SLIDE=NORMALLY LOCKED=ILOC	
CC	17	03 01421D	77341B SLIDE=NORMALLY LOCKED(C7-S)	
all	18	03 01425	75479B HANDLE=ILOC	
all	19	03 01422	94256C KEEPER=SPRING=ILOC	
all	20	03 01444A	77503B SPRING CUP = ILOC	
all	21	03 01444	82293ASPRING .51/1.69/46+CADPL	
all	22	03 01445	88481ASPRING .2/.625/.319+CADPL	
all	23	03 01445B	75935B TORQUE SPRING (.53 IN-#)CDPL	
all	24	03 01443	84251AFLATHDRIVET 5/32X2+5/16 ZINC	
all	25	15H090I	STRAIGHT PIN 5/32"DIAX1.75"L G ZINC	
AA only	26	03 S1X1	88172B SHIM:DOOR INTLK SOLENOID N4P	
all	27	27B205080Z	SPCRROLL.177ID.218L.027T STLZC	
B	27	27B205080E	01ZSPCRROLL.177ID.25L.027TK CSZNC	
BB,CC,DD	28	03 01418C	75736B KEEPER=NORMLOCKED SLIDE=ILOC	

Section

5

Chemical Supply Devices

Soap Chute Installation

3010 & 3015 G5E,G5X 3010 & 3015CGE
 30015V7J,T5J,T5E,C4A,C4T,C4E 30022V6J,V8Z,T5J,T5E,C4A,C4T,C4E



Pellerin Milnor Corporation
 P. O. Box 400, Kenner, LA 70063-0400

BMP000040/2010482B
 (Sheet 1 of 1)

Litho in U.S.A.

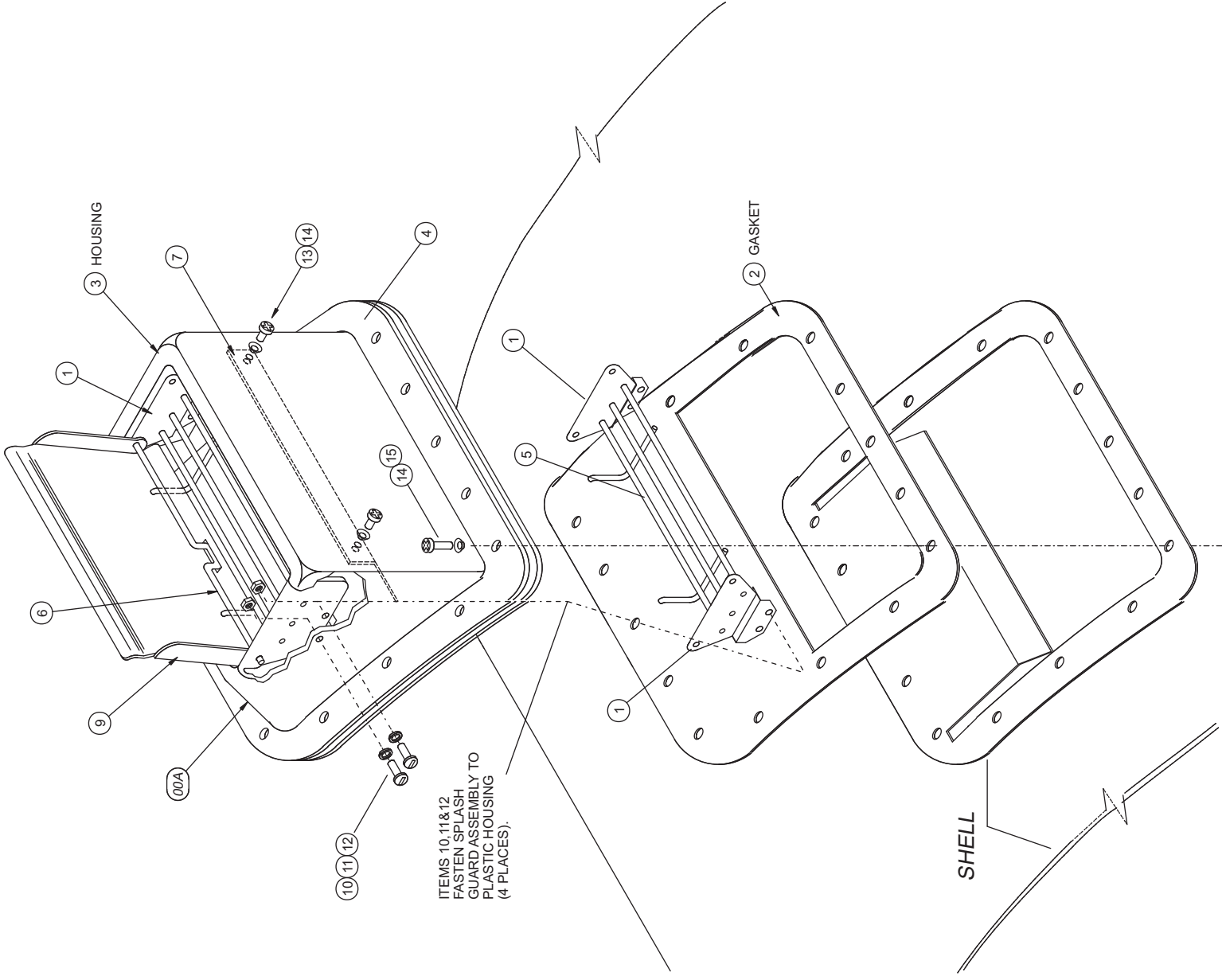

Parts List—Soap Chute Installation

Find the correct assembly first, then find the needed components. The item letters (A, B, C, etc.) assigned to assemblies are referred to in the "Used In" column to identify which components belong to an assembly. The item numbers (1, 2, 3, etc.) assigned to components relate the parts list to the illustration.

Used In	Item	Part Number	Description	Comments
	A	SA 33 058M	94000Z ASSY=PLSTC SOAP INLET	
			ASSEMBLIES	
			COMPONENTS	
all	1	02 03130	BRACKET=PLASTIC SOAP INLET	
all	2	02 03304D	GASKET=SOAPCHUTE 1/8"EPDM BL	
all	3	02 03589I	PLASTIC SHELLSIDE SOAP INLET	
all	4	02 03589T	BACKING RING=PLSTC CHEM INLT	
all	5	02 03594	GUARD SOAP CHUTE=CWU	
all	6	02 03595	PIN SOAP CHUTE HINGE=CWU	
all	7	02 03630A	SPLASH GUARD= SOAP CHUTE	
All	9	02 03593	89432B LID-SOAPCHUTE CWE TY304 SS	
all	10	15N133	RDMACSCR 10-24UNCZA X5/8" SS18	
all	11	15U160	LOCKWASHER MEDIUM #10 SS18-8	
all	12	15G130	HEXMACHSCRNUT 10-24UNC2 SS18-8	
all	13	15P050	PHDCUT-F PANHD 10-32X3/4 SS410	
all	14	24G018N	ROLLED WASH.194ID NYLTITE 10W	
all	15	15P051	TRDFRM AB HOLTHD 10-16X3/4SS41	

Peristaltic Supply Box

3010 & 3015 G5E,G5X,CGE

30015V7J,T5J,T5E,T5X,C4A,C4T 30022V6J,T5J,T5E,T5X,C4A,C4T

BMP000046/2009515B
(Sheet 1 of 2)



Pellerin Milnor Corporation
P. O. Box 400, Kenner, LA 70063-0400

Litho in U.S.A.

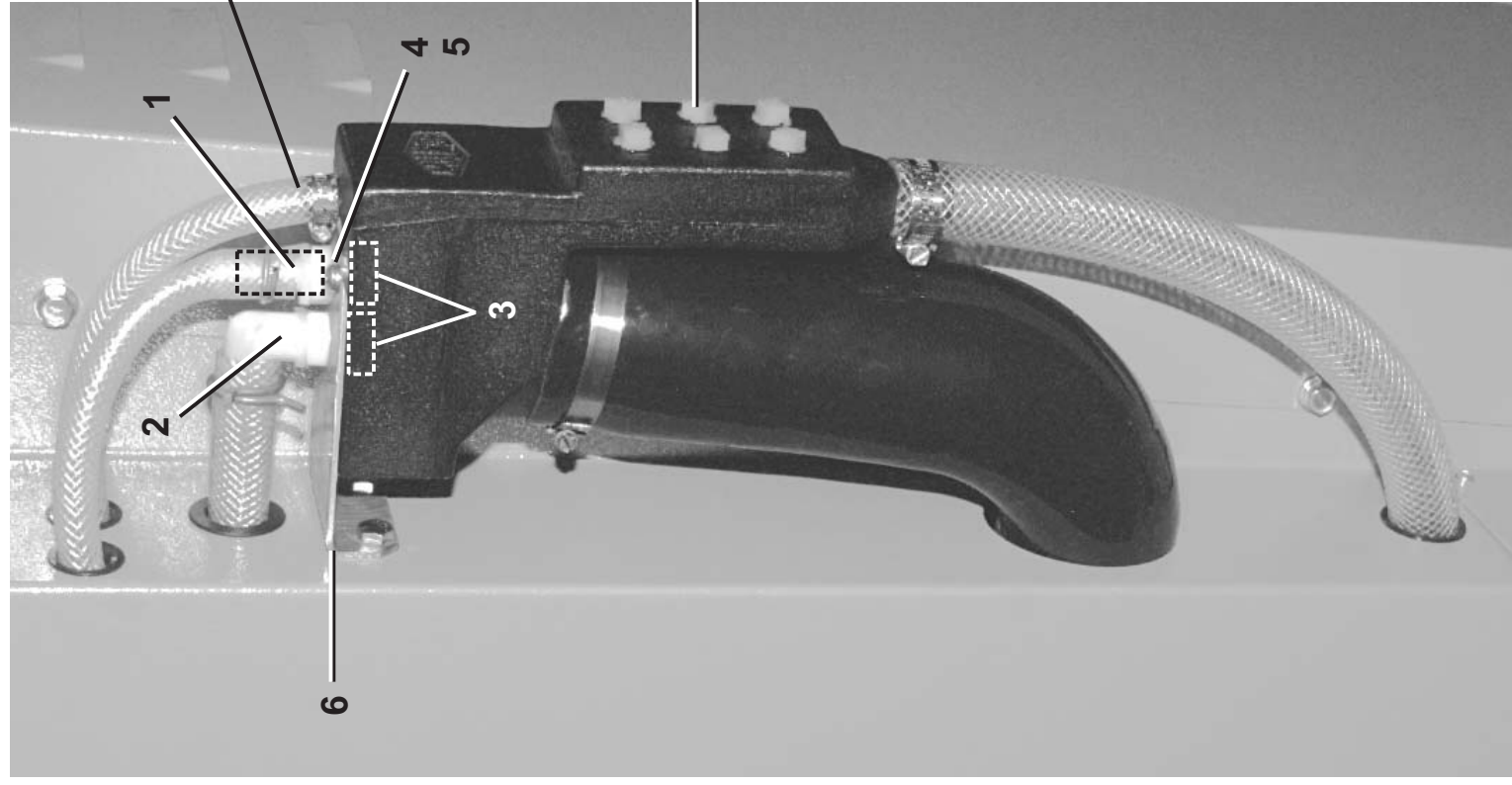

NOT USED
C4A,C4T
CGE

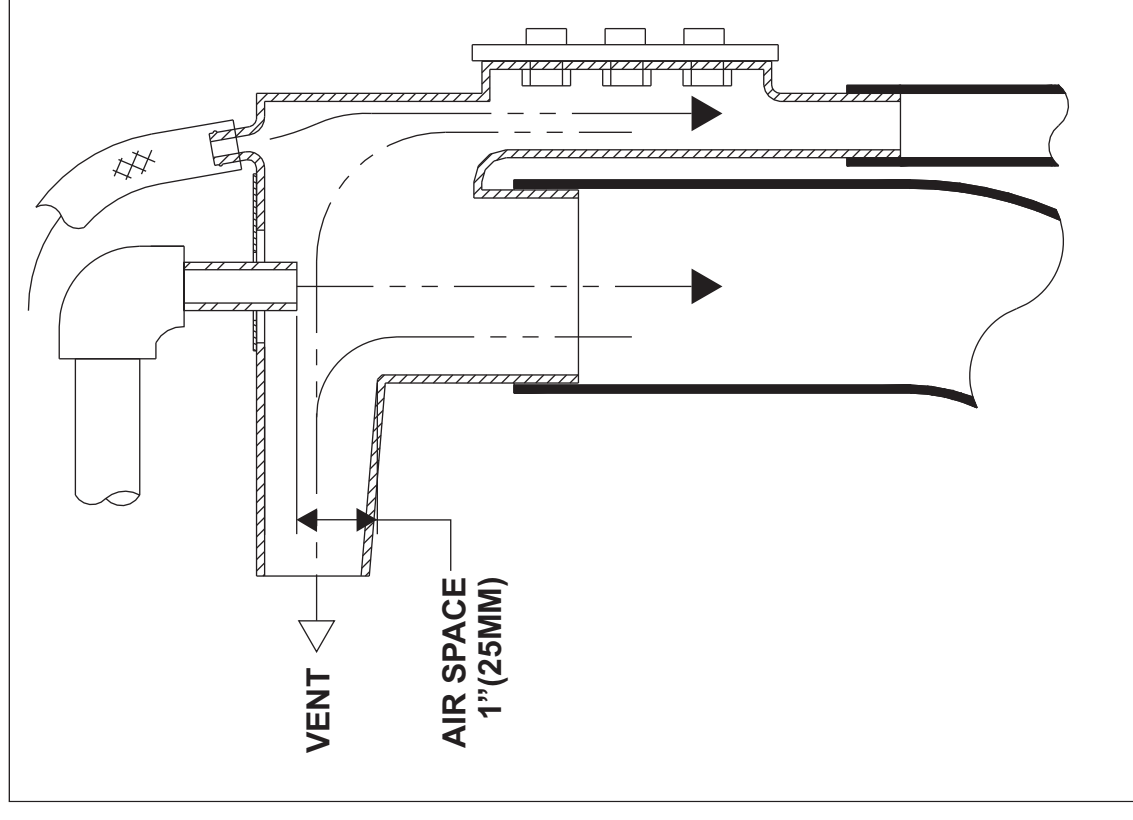

Detail: Air Gap



Pellerin Milnor Corporation
P. O. Box 400, Kenner, LA 70063-0400

Litho in U.S.A.

Parts List—Peristaltic Supply Box

Find the correct assembly first, then find the needed components. The item letters (A, B, C, etc.) assigned to assemblies are referred to in the "Used In" column to identify which components belong to an assembly. The item numbers (1, 2, 3, etc.) assigned to components relate the parts list to the illustration.

Used In	Item	Part Number	Description	Comments
..			-----ASSEMBLIES-----	
	A	SA 33 058P	ASSY=PLSTC PERSTL REAR INLET	
			-----COMPONENTS-----	
	1	51E513N	HOSEADPT3/4"HX11/16 W/NUT=NYL.	
	2	51E513EBN	3/4" 90DEG. ELBOW W/NUT	
	3	51E513NU	NUT 11/16 THRD.#64138 US PLAST	
	4	15K031	BUTSOKCAPSCR 1/4-20X1/2 SS18-8	
	5	15U181	LOCKWASHER MEDIUM 1/4 SS18-8	
	6	02 03588F	3015/20 PERST BOX TOP BRKT	
	7	02 03588E	PERISTALTIC/WATER INLET 30	
	8	51PB0GN	PLUG PIPE 3/8"NPT P-38 HD POLY	
	9	20C040	SIL SEAL RTV BLACK 85GR #59330	

3 Compartment Supply Injector

BMP770149/2000333V
(Sheet 1 of 2)



Pellerin Milnor Corporation
P. O. Box 400, Kenner, LA 70063-0400

Litho in U.S.A.

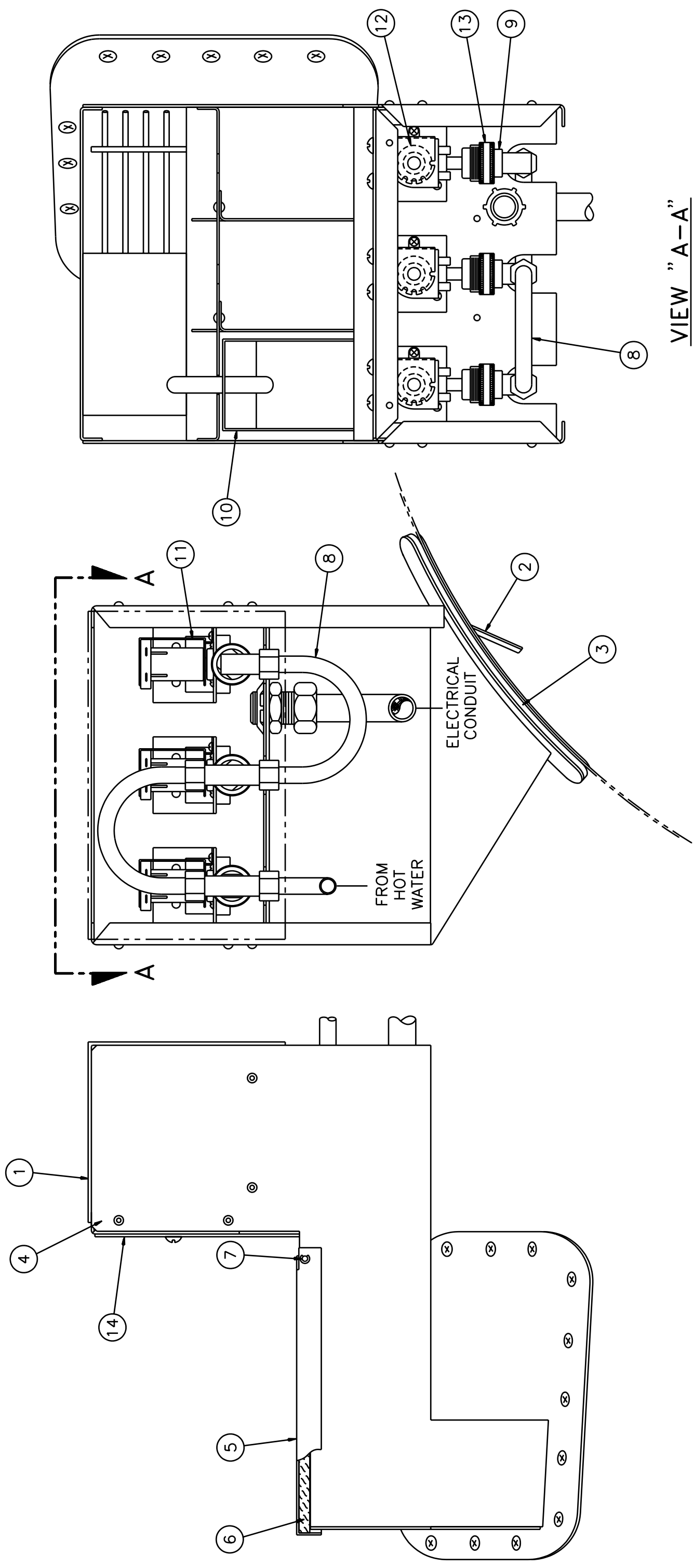

VIEW "A-A"
ITEMS 1, 5-7 LEFT OFF
THIS VIEW FOR CLARITY



Pellerin Milnor Corporation
P. O. Box 400, Kenner, LA 70063-0400

Litho in U.S.A.

Parts List—3 Compartment Supply Injector

Find the correct assembly first, then find the needed components. The item letters (A, B, C, etc.) assigned to assemblies are referred to in the "Used In" column to identify which components belong to an assembly. The item numbers (1, 2, 3, etc.) assigned to components relate the parts list to the illustration.

Used In	Item	Part Number	Description	Comments
-----ASSEMBLIES-----				
	A	GWS33001B	89241@ INSTALL 4SUP INJ SYSTEM 7	3 COMPARTMENT SUPPLY INSTALLATION CONTAINS ITEMS 4-13
	B	AWS33001B	89241D*ASSY=3FLUSH SUP INJ SYSTEM 7	
-----COMPONENTS-----				
all	1	02 03732B	94031B COVER 4 COMP SUPPLY VALVES	
all	2	02 03732F	90346C TAPPED PLATE=SUPPLY MOUNT	
all	3	02 03304A	94493C GASKET=SOAP CHUTE 1/8"EPDM	
all	4	W2 03732	93102D* SUPPLY INJECTOR 4 COMP SUPP	
all	5	02 03732G	87501C LID=4 COMPARTMENT SUPPLY	
all	6	02 03732U	78302B GASKET=LID 4 COMP SUPPLY	
all	7	02 03732S	78132B HINGE PIN=LID 4 COMP SUPPLY	
all	8	02 03732T	77411B TUBE COPPER-VALVE CONN. 3/8	
all	9	02 03732Z	83446B ADAPTER HOSE THD 3/4"X1/4 NPT	
all	10	W2 03732A	93303B* SUPPLY CUP WLMT 4 COMP SUPP	
all	11	96P013B71	04Z 3/4" 2WAY PLASTIC VALVE 240V60C	
all	12	60C007	RUBGROM #2861 1/2ID-13/16X1/8PNL MT	
all	13	53A060H	KNURLED HOSE NUT 3/4-HOSE PH#94GH-12	
all	14	01 10438X	95072B NPLT:3POCK SUPPLY SYSTEM7ISO	SYS 7 - HOTEL
all	14	01 10438Y	95072B NPLT:3POCK SUPPLY EP-PLUSISO	EP PLUS
all	14	01 10438L	92343C NPLT:M4A 3 COMPARTMENT SUPPY	M4A

Section

6

**Water and Steam Piping
and Assemblies**

Schematic Symbols Key

BMP920008/2000302V
(Sheet 1 of 1)



Pellerin Milnor Corporation
P. O. Box 400, Kenner, LA 70063-0400

Litho in U.S.A.

ISOMETRIC SYMBOLS

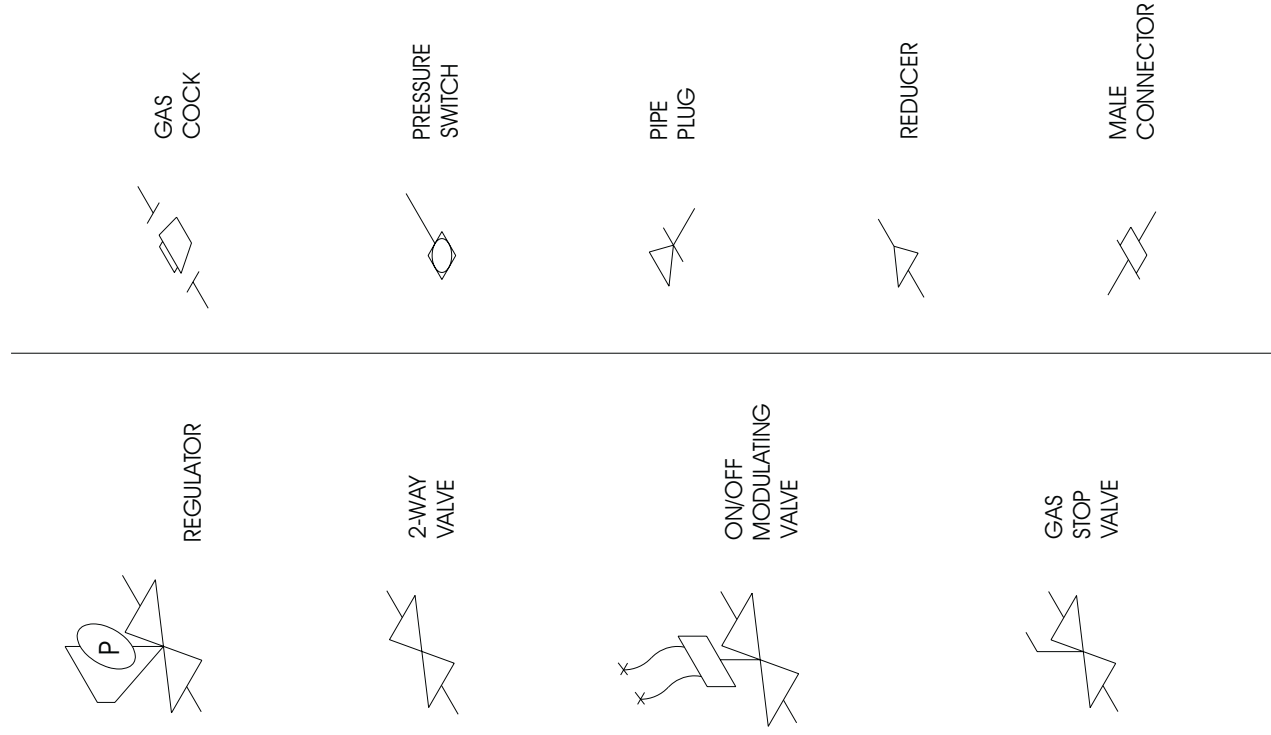

STANDARD SYMBOLS

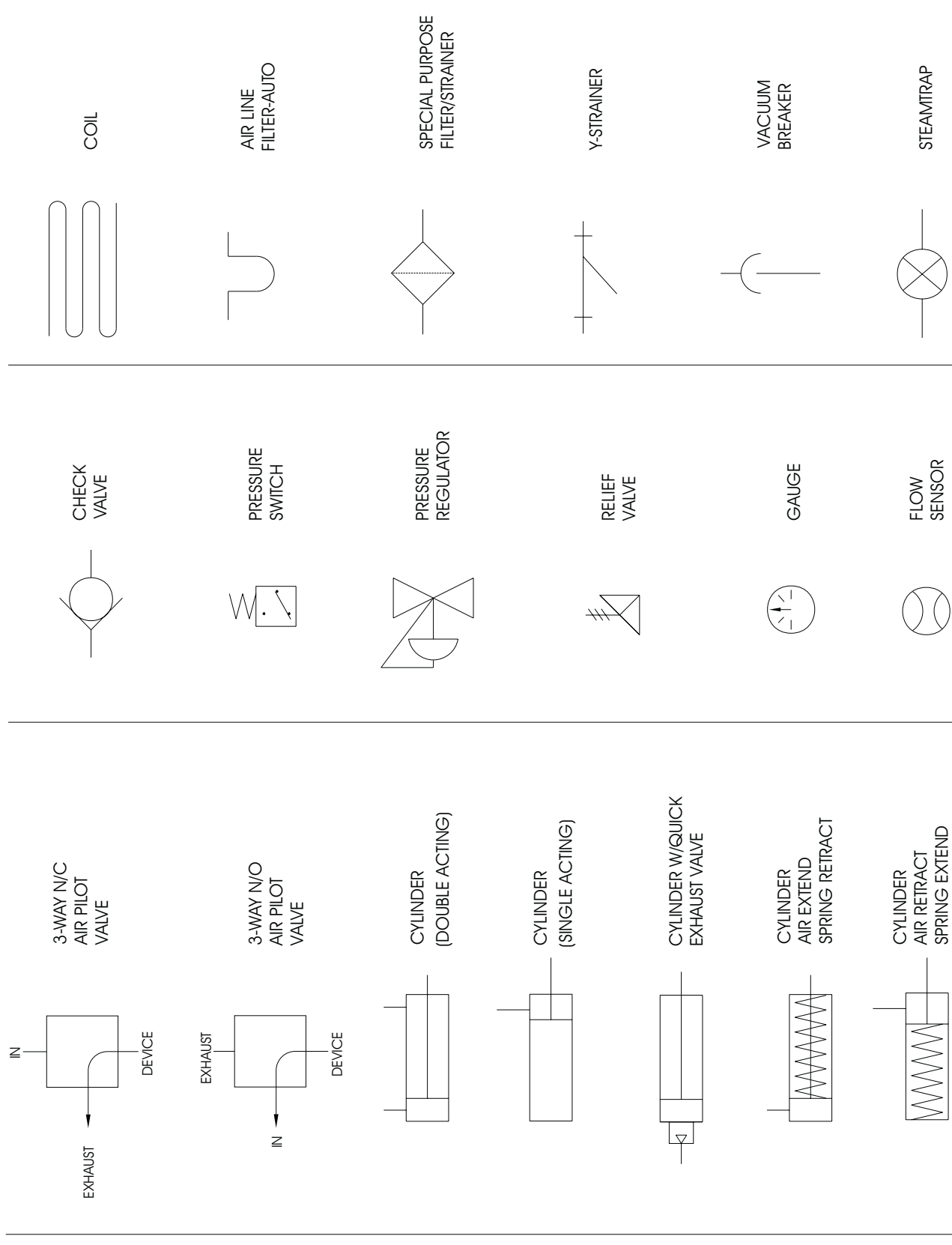

Water / Steam / Drain Schematics

30015V7J,T5E,T5X 30022V6J,T5E,T5X

BMP000049/2011045B
(Sheet 1 of 2)



Pellerin Milnor Corporation
P. O. Box 400, Kenner, LA 70063-0400

Litho in U.S.A.

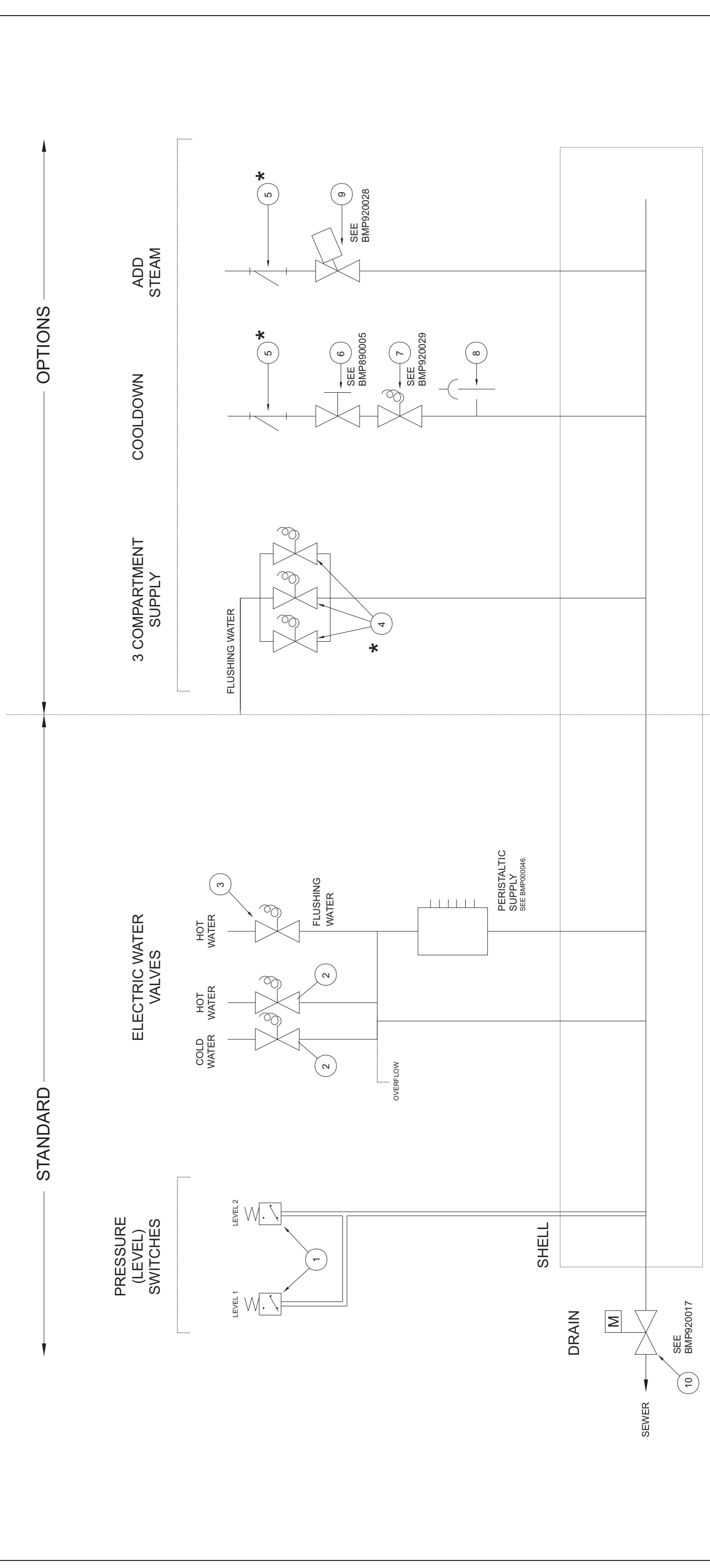

* - STRAINER MUST BE CLEANED, SEE "PREVENTIVE MAINTENANCE" IN THE TABLE OF CONTENTS.
 ** - PRESSURE REGULATOR MUST REMAIN SET AT THE FACTORY SETTING OF 28 P.S.I. SEE BMP900031 FOR MAINTENANCE PROCEDURES.



Pellerin Milnor Corporation
P. O. Box 400, Kenner, LA 70063-0400

Litho in U.S.A.

Parts List—Water/Steam/Drain Schematic

Find the correct assembly first, then find the needed components. The item letters (A, B, C, etc.) assigned to assemblies are referred to in the "Used In" column to identify which components belong to an assembly. The item numbers (1, 2, 3, etc.) assigned to components relate the parts list to the illustration.

Used In	Item	Part Number	Description	Comments
-----ASSEMBLIES-----				
	A	SA 33 058T	3015/22 BRASS WATER VALVE ASSY	3015V7J, 3022V6J
	B	SA 33 058V	3015/22 BRASS WATER VALVE ASSY PARKER	3015T5E, 3022T5E
	C	AWS33001B	*ASSY=3FLUSH SUP INJ SYSTEM 7	
-----COMPONENTS-----				
all	1	09N086A	PRESS SW INVENSYS #738-761	
A	2	96P057A71	1/2"NPT X 1/2"ORIFICE 240V 5/6	
B	2	96P057B71	1/2"NPT X 1/2"ORIFICE 240V 5/6 PARKER	
all	3	96P058A71	1/4"NPT X 1/8"ORIFICE 240V 5/6	
C	4	96P013B71	3/4" 2WAYPLASTICVAL 240V60C	
all	5	51T025	Y-STRAINER 1/2" CAST IRON	
all	6	96D034	BALLVALVE 1/2" WATTS #6400-SS	
all	7	96TDC2AA71	1/2"N/C2WY240V50/60C VLV	
all	8	96M021	1/2"VAC BREAKER #288A	
all	9	96P039A71	1/2"STEAMVAL240V50/60C 150PSI	
all	10	96D350A71	DRINVAL 3"N/O MTRDR240V 50/60C	

Water Inlet Assemblies with Peristaltic Supply
30015V7J 30022V6J

BMP000047/2011045B
 (Sheet 1 of 2)



Pellerin Milnor Corporation
 P. O. Box 400, Kenner, LA 70063-0400

Litho in U.S.A.

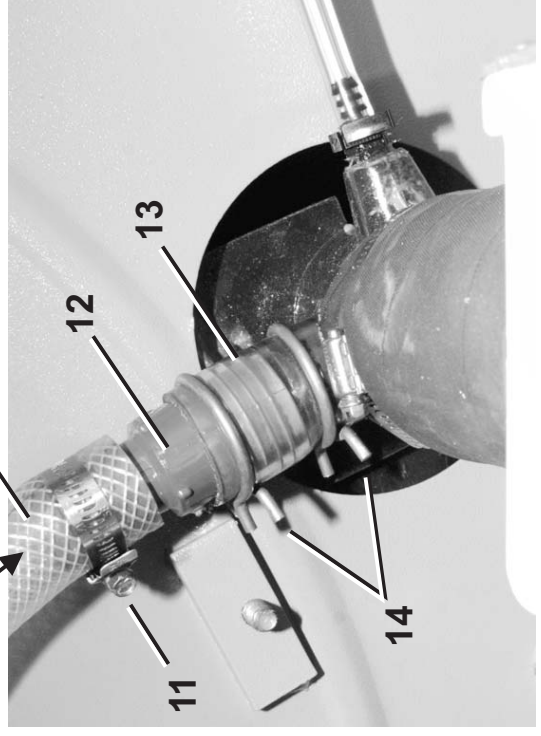
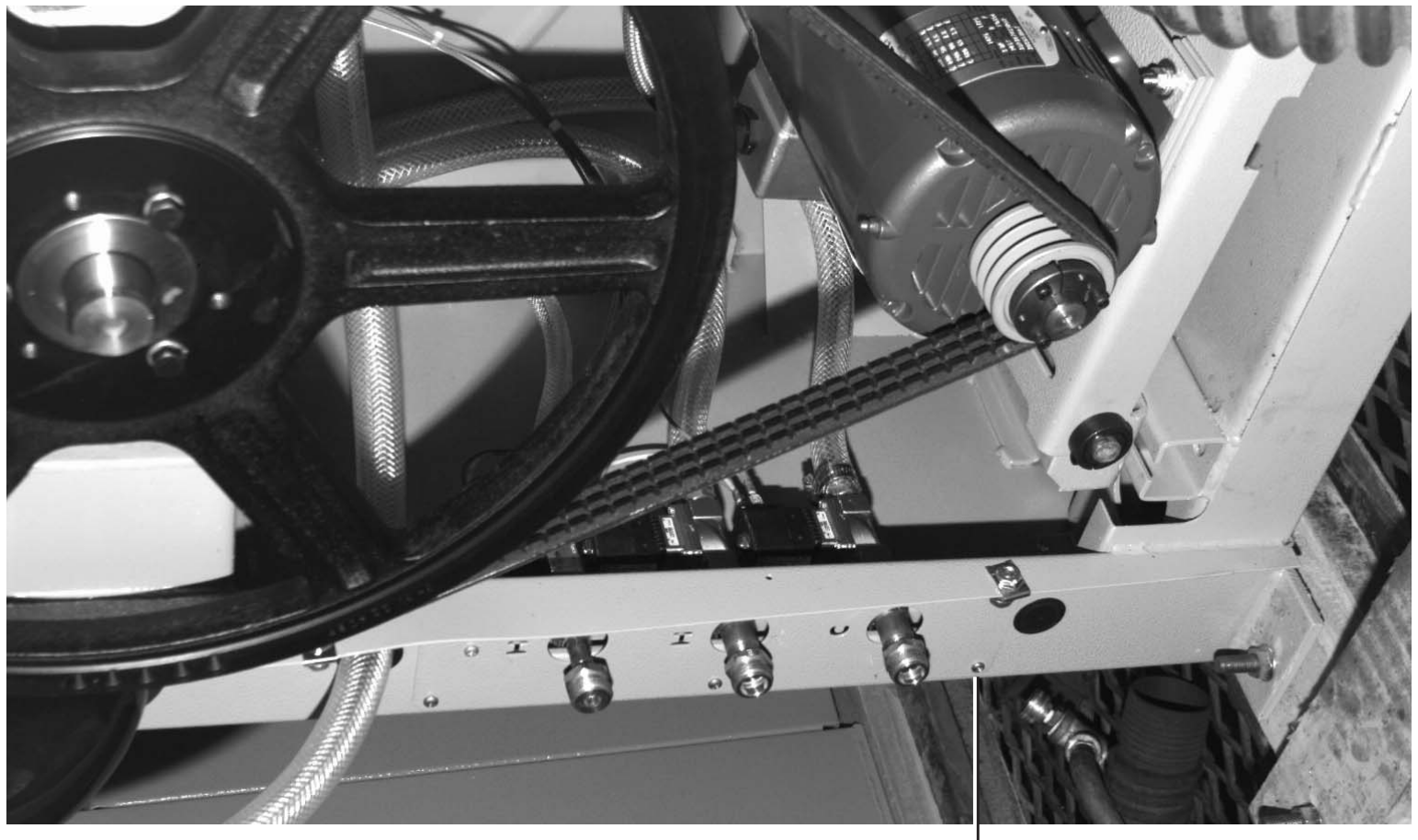
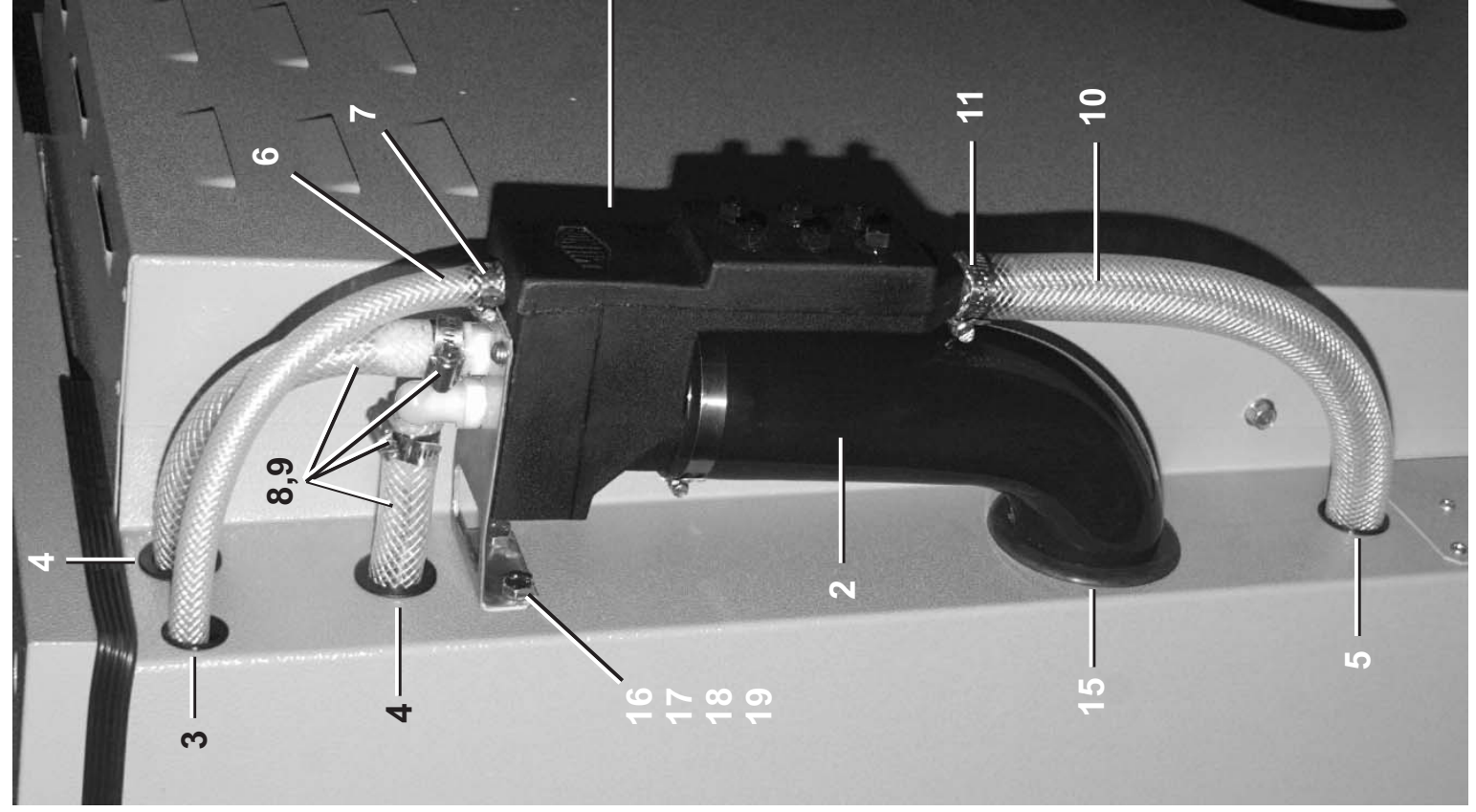

Water Inlet Assemblies with Peristaltic Supply

30015V7J 30022V6J

BMP000047/2011045B
(Sheet 2 of 2)



Pellerin Milnor Corporation
P. O. Box 400, Kenner, LA 70063-0400

Litho in U.S.A.

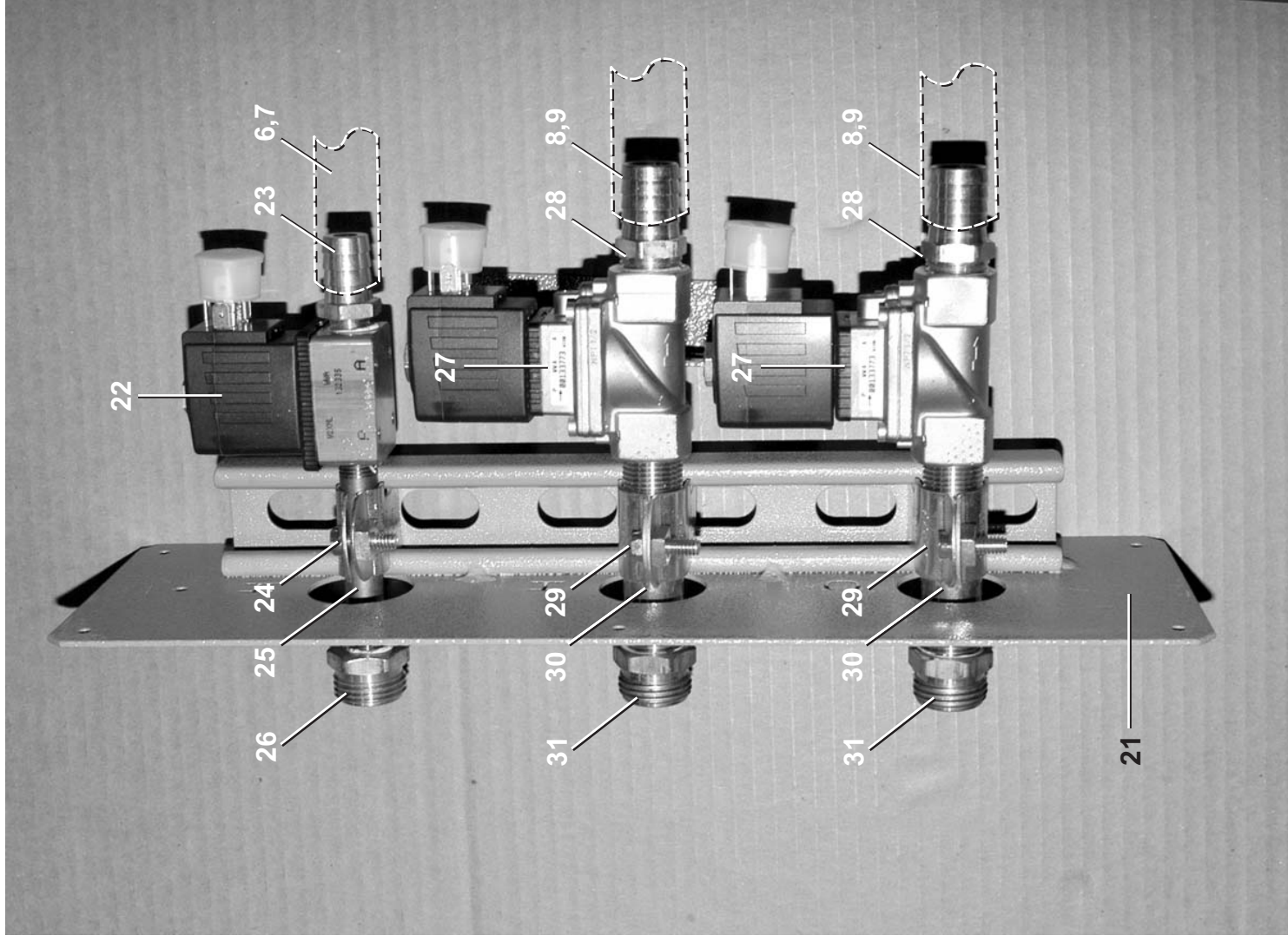

Parts List—Water Inlet Assemblies

Find the correct assembly first, then find the needed components. The item letters (A, B, C, etc.) assigned to assemblies are referred to in the "Used In" column to identify which components belong to an assembly. The item numbers (1, 2, 3, etc.) assigned to components relate the parts list to the illustration.

Used In	Item	Part Number	Description	Comments
			-----ASSEMBLIES-----	
	A	GA 33 058P	INST=H2O+PERSTAL REAR INLET	
	B	SA 33 058T	3015/22 BRASS WATER VALVE ASSY	
	C	SA 33 058P	ASSY=PLSTC PERSTL REAR INLET	
			-----COMPONENTS-----	
all	1	SA 33 058P	ASSY=PLSTC PERSTL REAR INLET	
all	2	02 03588B	PARISTALTIC/WATER INLET LONG HOSE	
all	3	12P11CSB	SNAPBUSH 1.093"MH X .94"ID HEYCO#2166	
all	4	12P11KSB	SNAPBUSH 1.50" X 1.06" #22MP15017	
all	5	12P11JSB	SNAPBUSH 1.50"MH X 1.312 HEYCO#2240	
all	6	60E007C	TUBING NYL.REINF.5/8"IDX.8750D	
all	7	27A044	HOSECLAMP 5/8"ID BREEZE#6706SS	
all	8	60E008A	TUBINGNYLREINF.75"IDX1.025"OD	
all	9	27A044S	HOSECLAMP 11/16-1.25SSCR#64012	
all	10	60E010	TUBINGPOLYBRAID 1"X1.312	
all	11	27A090S	HOSECLAMP 13/16-1.5"SS#64016B	
all	12	51AB1EN1A	INSERT REDUCER PVC 1+1/4"X 1"	
all	13	60E014A02A	HOSE 1.25IDX2"LG PVC	
all	14	27A052	HOSECLAMP 1.5"DIA.SPRG#HC24STZD	
all	15	60C121	GROMMET-FILLTUBE3015/22	
all	16	15G205	HXNUT 3/8-16UNC2B ZINC GR2	
all	17	15U240	FLATWASHER(USS STD) 3/8" ZNC P	
all	18	15U255	LOCKWASHER MEDIUM 3/8 ZINCPL	
all	19	15K085	HEXCAPSCR 3/8-16UNC2AX3/4 GR5	
all	20	15P011	TRDCUT-F PANHD 10-24X1/2 NIKST	
all	21	W2 03588S	3015/22 BRASS H2O MNT WLMT (COLOR=WARM GRAY)	
all	23	51E507D	HOSESTEM BRASS 1/4MPX5/8HOSEID	
all	32	10Y75V6JWV	HARNESS FOR VALVES	

Water Inlet Assemblies with Peristaltic Supply

30015T5E, T5X 30022T5E, T5X

BMP110009/2011045B
(Sheet 1 of 2)



Pellerin Milnor Corporation
P. O. Box 400, Kenner, LA 70063-0400

Litho in U.S.A.

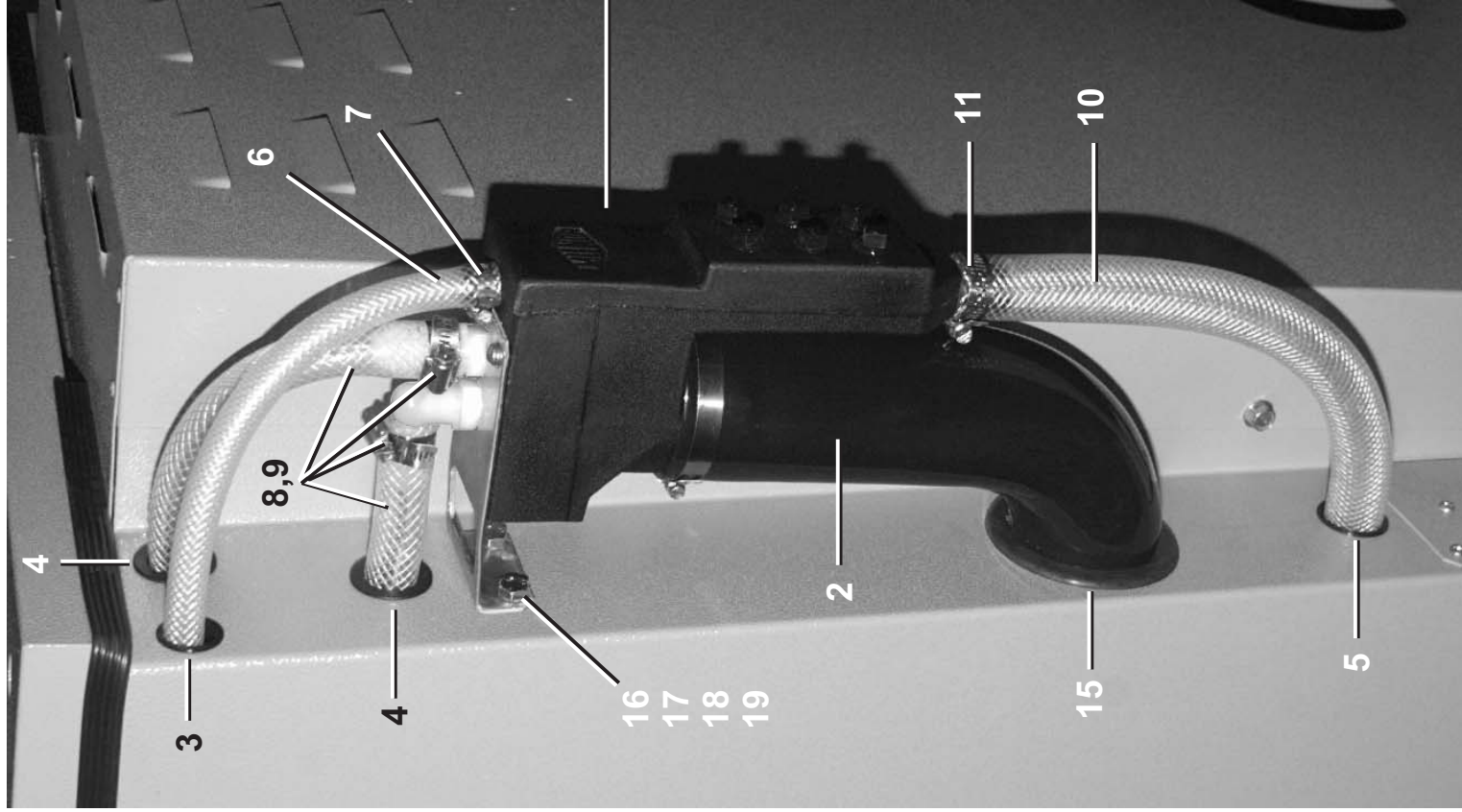

PERISTALTIC SUPPLY

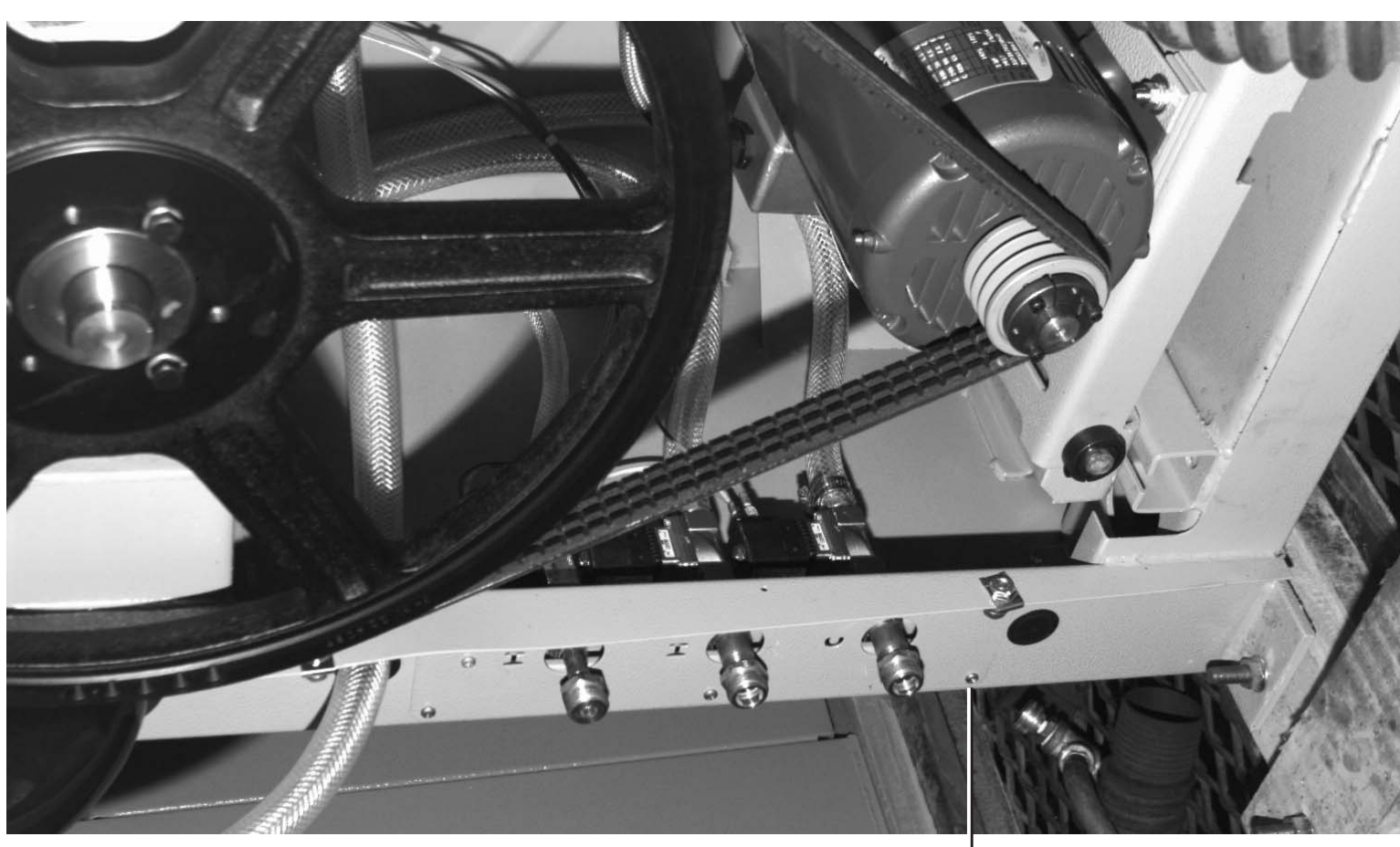
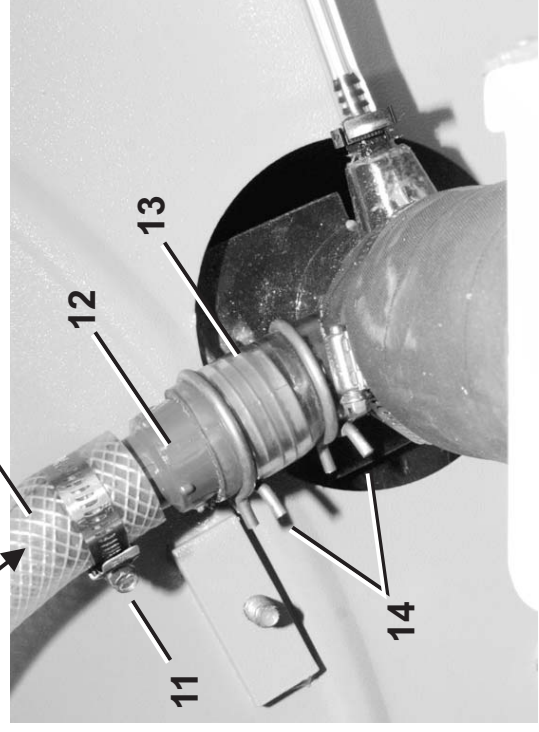

Water Inlet Assemblies with Peristaltic Supply

30015T5E, T5X 30022T5E, T5X

BMP110009/2011045B
(Sheet 2 of 2)



Pellerin Milnor Corporation
P. O. Box 400, Kenner, LA 70063-0400

Litho in U.S.A.

Parts List—Water Inlet Assemblies

Find the correct assembly first, then find the needed components. The item letters (A, B, C, etc.) assigned to assemblies are referred to in the "Used In" column to identify which components belong to an assembly. The item numbers (1, 2, 3, etc.) assigned to components relate the parts list to the illustration.

Used In	Item	Part Number	Description	Comments
	A	SA 33 058V	3015/22 BRASS WATER VALVE ASSY PARKER	
			-----ASSEMBLIES-----	
			-----COMPONENTS-----	
all	1	02 03585A	PARISTALTIC WATER INLET 30	
all	2	02 03585C	PARISTALTIC WATER INLET SHORT HOSE	
all	3	12P11CSB	SNAPBUSH 1.093"MH X .94"ID HEYCO#2166	
all	4	12P11KSB	SNAPBUSH 1.50" X 1.06" #22MP15017	
all	5	12P11JSB	SNAPBUSH 1.50"MH X 1.312 HEYCO#2240	
all	6	60E007C	TUBING NYL REINF.5/8"IDX.8750D	
all	7	27A044	HOSECLAMP 5/8"ID BREEZE#6706SS	
all	8	60E008A	TUBING NYL REINF.75"IDX1.025"OD	
all	9	27A044S	HOSECLAMP 11/16-1.25SSCR#64012	
all	10	60E010	TUBING POLYBRAID 1"X1.312	
all	11	27A090S	HOSECLAMP 13/16-1.5"SS#64016B	
all	12	51AB1EN1A	INSERT REDUCER PVC 1+1/4"X 1"	
all	13	60E014A02A	HOSE 1.25IDX2"LG PVC	
all	14	27A052	HOSECLAMP 1.5"DIA.SPRG#HC24STZD	
all	15	60C121	GROMMET-FILL TUBE 3015/22	
all	16	15G205	HXNUT 3/8-16UNC2B ZINC GR2	
all	17	15U240	FLATWASHER(USS STD) 3/8" ZNC P	
all	18	15U255	LOCKWASHER MEDIUM 3/8 ZINCPL	
all	19	15K085	HEXCAPSCR 3/8-16UNC2AX3/4 GR5	
all	20	15P011	TRDCUT-F PANHD 10-24X1/2 NIKST	
all	21	W2 03588S	3015/22 BRASS H20 MNT WLMT	
all	22	96P058A71	1/4"NPT X 1/8"ORIFICE 240V 5/6	
all	23	51E507D	HOSESTEM BRASS 1/4MPX5/8HOSEID	
all	24	27A0650CLP	TUBING CLP 1/2"OD #PS1200-1/2	
all	25	5N0E03KBE2	NPT NIP 1/4X3.5 TBE BRASS STD	
all	26	51E513A	3/4"MHX1/4"FP PARKER#78GH-12-4	
all	27	96P057B71	1/2"NPT X 1/2"ORIFICE 240V 5/6 PARKER	
all	28	51E510	HOSESTEM BRASS 1/2MPX3/4HOSEID	
all	29	27A0050	CLP-RGDSTL COND #PS1100-1/2	
all	30	5N0K03KB42	NPT NIP 1/2X3.5 TBE BRASS STD	
all	31	51E513B	3/4"MHX1/2"FP PARKER#80GH-12-8	
all	32	10Y75V6JWVA	HARNES FOR VALVES PARKER	

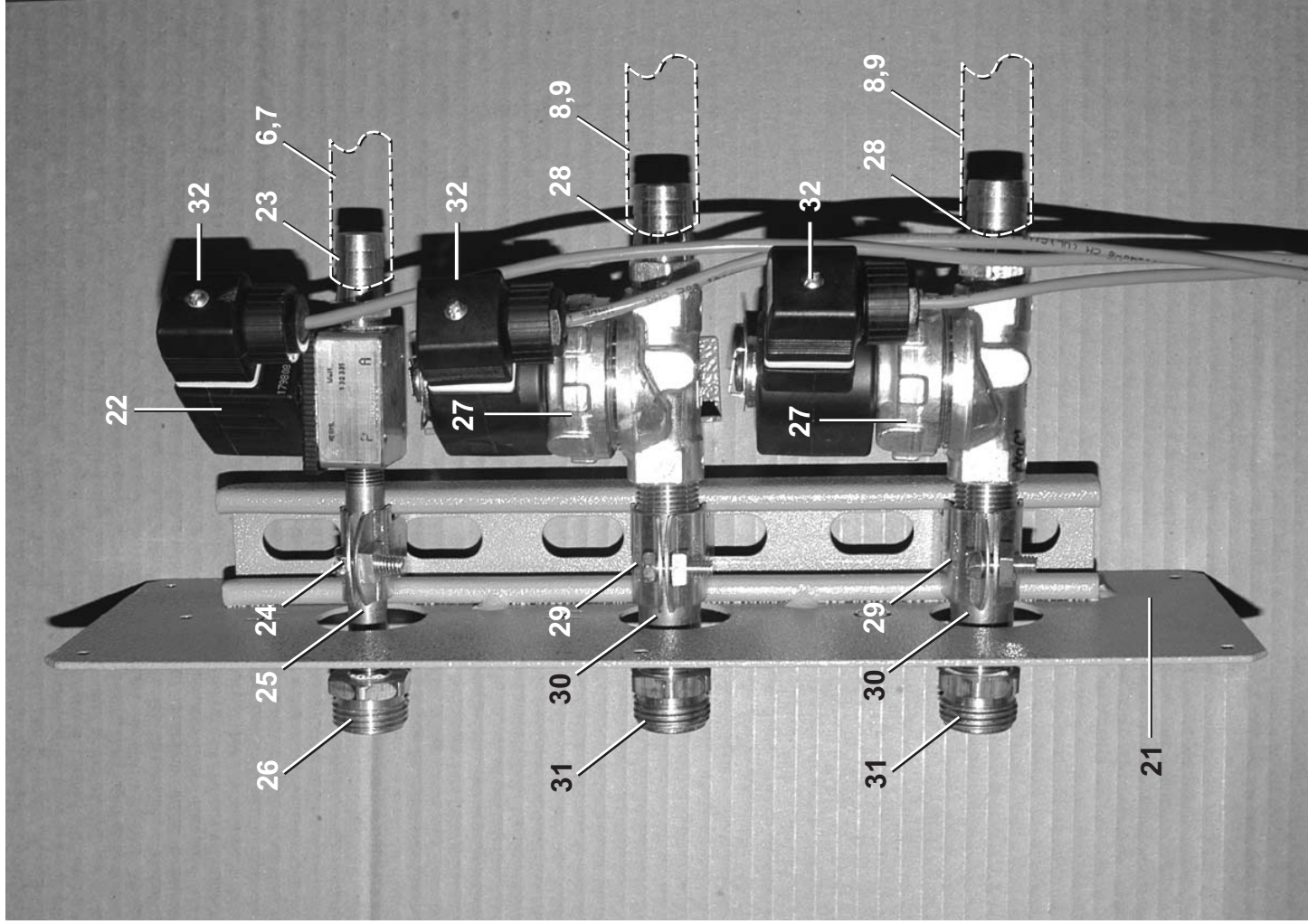

Level Switches

30015V7J,T5J,T5E 30022V6J,T5J,T5E



Pellerin Milnor Corporation
P. O. Box 400, Kenner, LA 70063-0400

BMP000069/2010093B
(Sheet 1 of 2)

Litho in U.S.A.

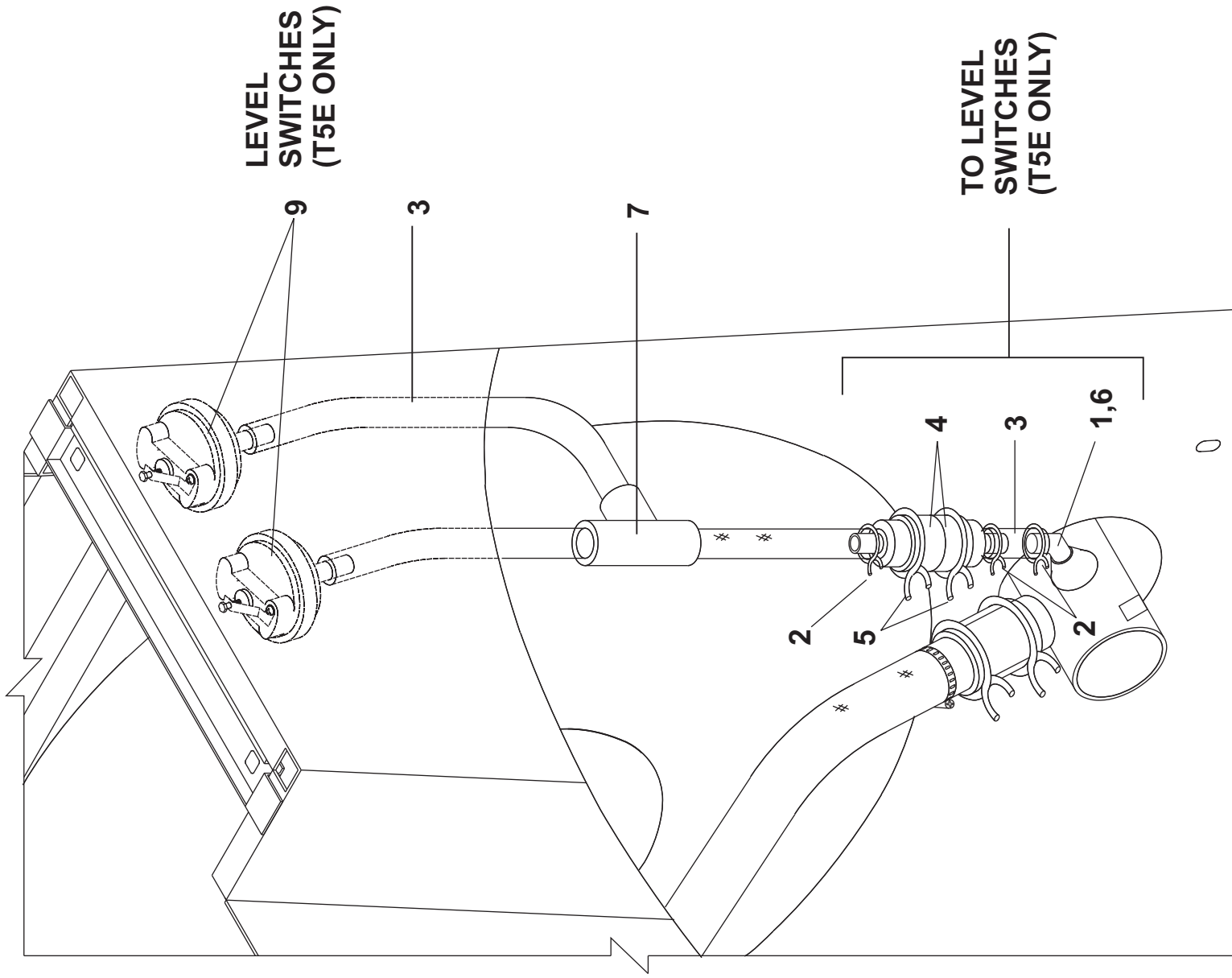

LEVEL SWITCHES
(T5E ONLY)

TO LEVEL SWITCHES
(T5E ONLY)

TO TRANSDUCER
ON PROCESSOR
BOARD

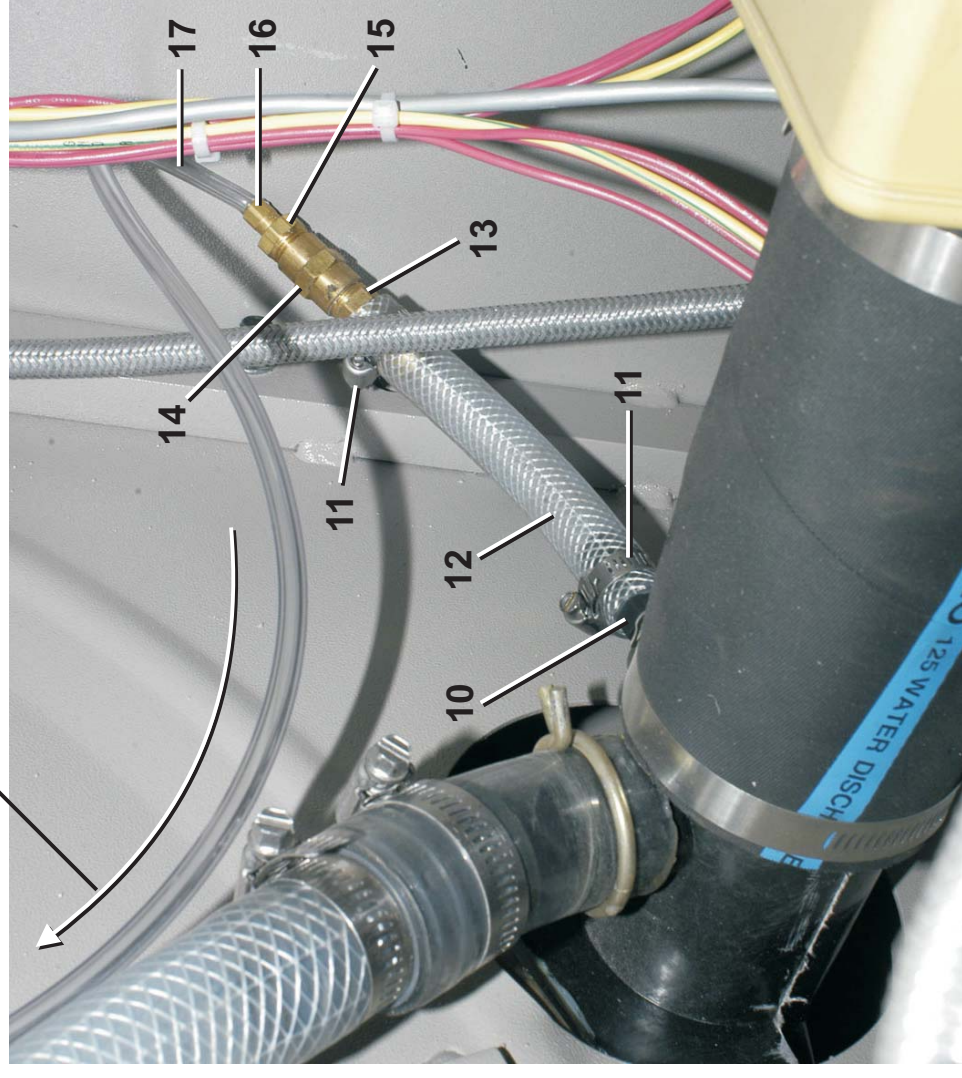

DETAIL A: TO TRANSDUCER
30015V7J/T5J, 30022V6J/T5J



Pellerin Milnor Corporation
P. O. Box 400, Kenner, LA 70063-0400

Litho in U.S.A.

Parts List - Level Switches

Find the correct assembly first, then find the needed components. The item letters (A, B, C, etc.) assigned to assemblies are referred to in the "Used In" column to identify which components belong to an assembly. The item numbers (1, 2, 3, etc.) assigned to components relate the parts list to the illustration.

Used In	Item	Part Number	Description	Comments
-----COMPONENTS-----				
all	1	51E509	HOSESTEM BRASS 1/2MPX1/2HOSEID	
all	2	27A044A	HOSECLAMP.687"ID ROTOR#HC11STR	
all	3	60E005P	PVC TUBING 1/2"ID X 5/8"OD	
all	4	02 03332C	AIRCHAMBER=PRESSWITH-CWU	
all	5	27A052	HOSECLAMP 1.5"DIA.SPRING#R24HC	
all	6	51E502P	HOSE ADPT.1/4"MPX3/16H POLY-E	
all	7	5S0KQ8A	TEE 1/2"SOC CTS CPVC BEIGE	
All	8	60E005P	PVC TUBING 1/2"ID X 5/8"OD	
All	9	09N086A	PRESS SW INVENSYS #738-761	
All	10	51E507N	HOSESTEM NYLON 1/4MPX1/2HOSEID	
All	11	27A040	HOSECLAMP 7/16-25/32SS W/SCREW	
All	12	60E006C	PVC TUBING NYL.REINF.5IDX.75OD	
All	13	51E507	HOSESTEM BRASS 1/4MPX1/2HOSEID	
All	14	5SCC0EBE	NPT COUP 1/4 BRASS 125# W/HEX	
All	15	51E502B	HOSESTEM BRASS 1/4MPX1/8HOSEID	
All	16	27A047	HOSECLMP 1/8HOSEID CLIP#5000-2	
All	17	60E004NT	TUBING (NYL.)CLR.1/4"ODX1/8"	

1/2" & 3/4" Hayes Electric Steam Valves

BMP920028/2000302V
(Sheet 1 of 1)



Pellerin Milnor Corporation
P. O. Box 400, Kenner, LA 70063-0400

Litho in U.S.A.

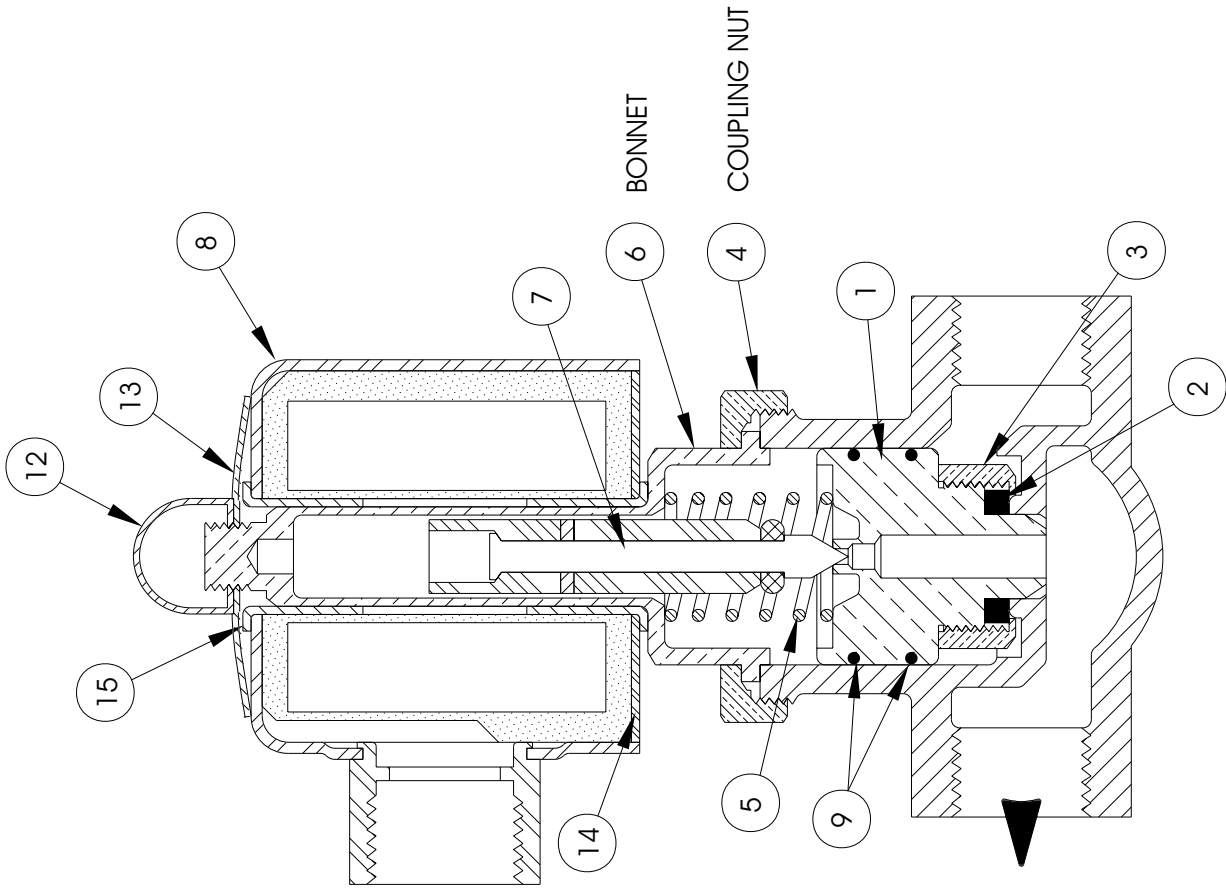

GENERAL MAINTENANCE:

1. COUPLING NUTS MUST NOT BE TIGHTENED EXCESSIVELY. USE A STEADY PULL WITH A 14" OR SMALLER WRENCH. DO NOT HAMMER ON NUT OR WRENCH. LIMIT MAXIMUM TORQUE ON COUPLING NUT TO 600LB/INCH. EXCESSIVE TIGHTENING OF COUPLING NUT WILL DISTORT VALVE BODY CAUSING THE PISTON BODY TO JAM AND THE VALVE TO SHUT OFF.
2. IF THE VALVE LEAKS BETWEEN THE BODY AND BONNET, LOOSEN THE COUPLING NUT AND TURN THE BONNET SLIGHTLY, THEN TIGHTEN THE COUPLING NUT. IF THE VALVE STILL LEAKS, REPEAT THE OPERATION. IN NO CASE MUST THE COUPLING NUT BE TIGHTENED EXCESSIVELY.

Parts List—Electric Steam Valve

Find the correct assembly first, then find the needed components. The item letters (A, B, C, etc.) assigned to assemblies are referred to in the "Used In" column to identify which components belong to an assembly. The item numbers (1, 2, 3, etc.) assigned to components relate the parts list to the illustration.

Used In	Item	Part Number	Description	Comments
			-----ASSEMBLIES-----	
A		96P039	1/2" STEAMVAL 24V50/60C 150PSI	1/2" VALVE- 24 VOLT
B		96P039A37	1/2" STEAMVAL 120V50/60C 150PSI	1/2" VALVE- 120 VOLT
C		96P039A71	1/2" STEAMVAL 240V50/60C 150PSI	1/2" VALVE- 240 VOLT
D		96P040E	3/4" STEAMVAL 24V50/60C 150PSI	3/4" VALVE- 24 VOLT
E		96P040A37	3/4" STEAMVAL 120V50/60C 150PSI	3/4" VALVE- 120 VOLT
			-----COMPONENTS-----	
A,B,C	1	96V224S	PISTON ASSY STEAMVAL HAYS #763	
D,E	1	96V224SA	PISTON ASSY STEAMVAL HAYS #777	
A,B,C	2	96V225S	PISTON SEAT WASHER HAYS #85553	
D,E	2	96V225SA	PISTON SEAT WASHER HAYS #85567	
A,B,C	3	96V248	SEAT WASHER NUT HAYS #82222 96P0	
D,E	3	96V226	SEAT WASHER FOR 96P053 HAYS	
A,B,C	4	96V246	COUPLING NUT FOR 96P014&96P016	
D,E	4	96V254	COUPLING NUT HAYS #76028 = 9	
A,B,C	5	96V244	PISTON SPRING FOR HAYS 3/08	
D,E	5	96V222A	PISTON SPRING HAYS 82488	
A,B,C	6	96V242	BONNET FOR HAYS 3108 HAYS83021	
D,E	6	96V260	BONNET HAYS #83192 FOR 96P151	
all	7	96V223	PLUNGER HAYS #7319503	
A,D	8	96P040V24	COIL 1/2" & 3/4" STEAMVALVE 24V5	
B,E	8	96P040V37	COIL 1/2" & 3/4" STEAMVALVE 120V5	
C	8	96P040V71	COIL 1/2" & 3/4" STEAMVALVE 240V	
A,B,C	9	96V222TS	TEFLON SPLIT RING HAYS #86334	
D,E	9	96V222TSA	TEFLON SPLITRING STEMVAL HAYS#	
all	12	96V250	PALNUT HAYS #3069-PC	
all	13	96V251	SPRING WASHER HAYS #83600	
all	14	96V264	BOTTOM PLATE (COIL) HAYS#8223	
all	15	96V262	FERRULE (COIL SLEEVE) HAYS #82	

2-Way Electric Water Valve

BMP920029/98443V
(Sheet 1 of 2)



Pellerin Milnor Corporation
P. O. Box 400, Kenner, LA 70063-0400

Litho in U.S.A.

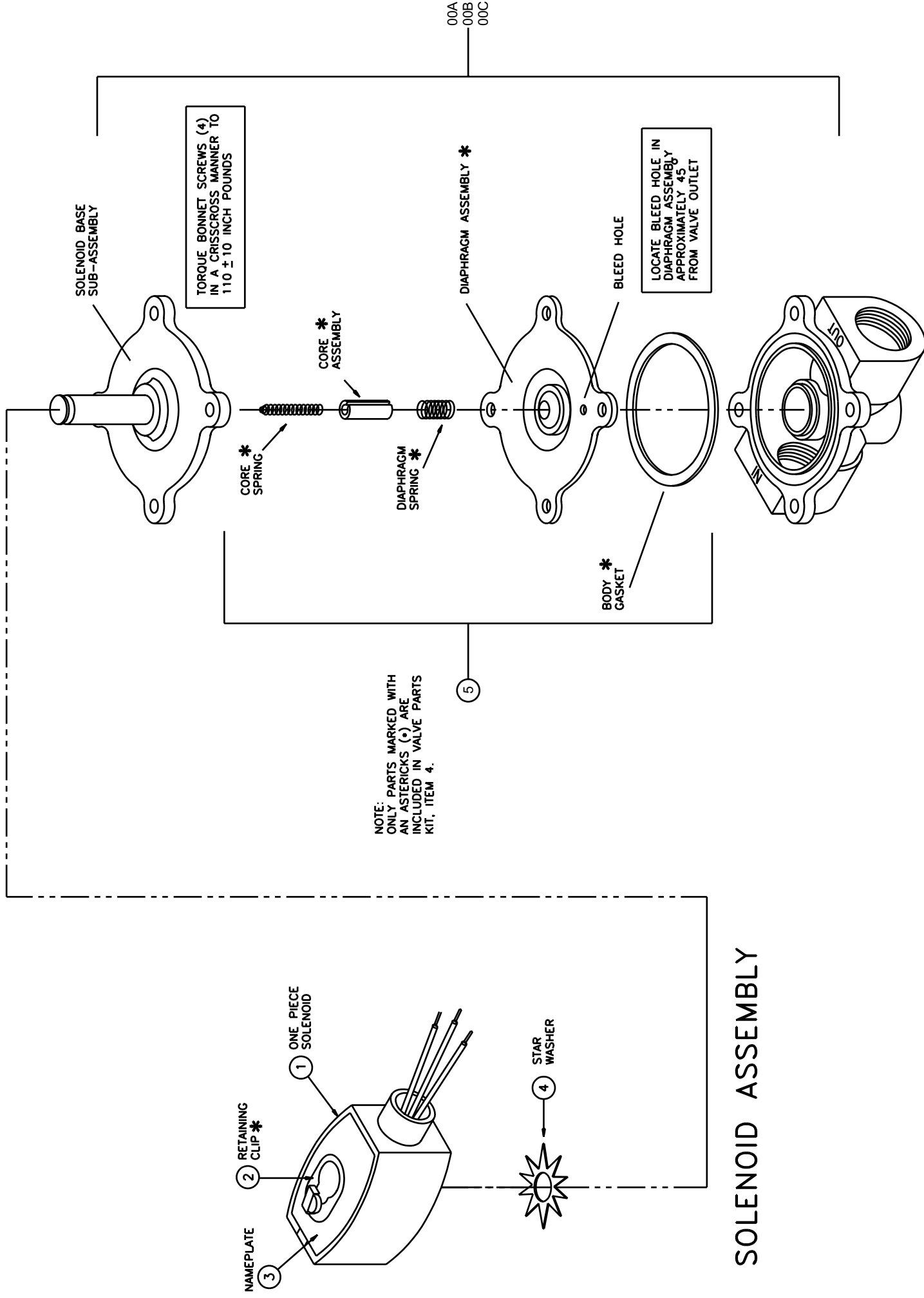

Identification and Description

Check nameplate for correct catalog number, pressure, voltage, and service.

Safety Instructions



⚠ DANGER ⚠

SHOCK HAZARD will cause death or severe injury.
Lock OFF and tag out power at wall disconnect before servicing. Power switches on machine and control box disable only control circuit power in electrical boxes.



⚠ WARNING ⚠

EXPLOSION HAZARD may cause serious injury.
Release pressure to valve before disassembly.



⚠ CAUTION ⚠

BURN HAZARD Solenoid enclosures become too hot to touch when energized for a long period. This will not damage the solenoid, but may cause a painful burn.
Allow solenoids to cool before servicing the valves.

Maintenance

READ ALL SAFETY STATEMENTS ABOVE BEFORE PROCEEDING ANY FURTHER!

Coil Replacement

1. Remove retaining clip. NOTE: When metal retaining clip disengages, it springs upwards.
2. Slip yoke containing coil and sleeves off solenoid base sub-assembly.
3. Replace coil.
4. Reassemble in reverse order.

Valve Disassembly and Reassembly

1. Remove retaining clip.
2. Slip entire solenoid enclosure off the solenoid base sub-assembly.
3. Remove solenoid base sub-assembly, core assembly and core spring.
4. Remove diaphragm spring, diaphragm assembly and gasket.
5. Replace all worn or damaged parts.
6. Reassemble in reverse order.

Troubleshooting

Control Circuit: Listen for a metallic click when energizing the solenoid. Absence of the click indicates loss of power to the solenoid. Check for loose connections, blown fuses, open or grounded coil circuit, and broken lead wires.

Faulty coil: Check for open circuit in coil. Replace coil if necessary.
Low voltage: Voltage across coil leads must be at least 85% of nameplate rating for proper operation.

Incorrect pressure: Pressure to valve must be within range specified on nameplate.
Excess leakage: Disassemble valve and clean all parts. Replace all worn parts for best results.



Pellerin Milnor Corporation
 P. O. Box 400, Kenner, LA 70063-0400

Litho in U.S.A.

Parts List—2-Way Electric Water Valve

Used In	Item	Part Number	Description	Comments
	00A	96TDC2AA24	03Z 1/2" N/C 2WAY 24V50/60C VALVE	VALVE ASSEMBLY
	00B	96TDC2AA37	03Z 1/2" N/C 2WAY 120V50/60C VALVE	VALVE ASSEMBLY
	00C	96TDC2AA71	03Z 1/2" N/C 2WAY 240V50/60C VALVE	VALVE ASSEMBLY
	001A	96T1001A24	SOLENOID 24V50/60C ASCO#260283-001	USED WITH 00A
	001B	96T1001A37	SOLENOID 120V50/60C ASCO#260283-002	USED WITH 00B
	001C	96T1001A71	SOLENOID 240V50/60C ASCO#260283-003	USED WITH 00C
	002	96V1001CLP	METAL CLIP M6	USED IN 00A, 00B, 00C
	003	96V1001PLT	NAMPLATE, BLANK REDHAT II COIL M6	USED IN 00A, 00B, 00C
	004	96V1001WSH	STAR WASHER REDHAT II COIL M6	USED IN 00A, 00B, 00C
	005	96V235B	PARTKIT ASCO #K258-120 FOR 8210D2	REPAIRS 00A, 00B, 00C

Steam Inlet
3015V6J, 3022V6J

BMP110013/2011064B
(Sheet 1 of 2)



Pellerin Milnor Corporation
P. O. Box 400, Kenner, LA 70063-0400

Litho in U.S.A.

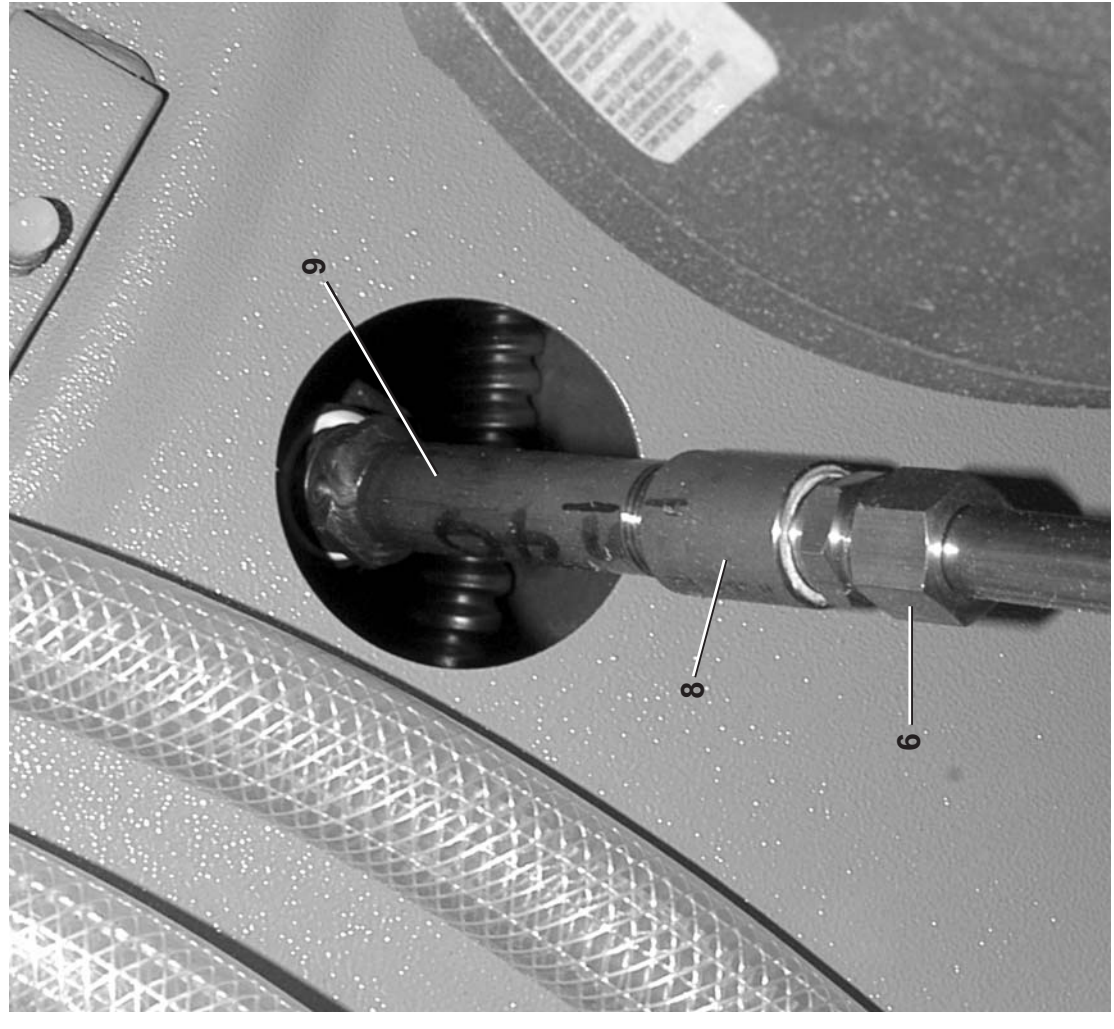
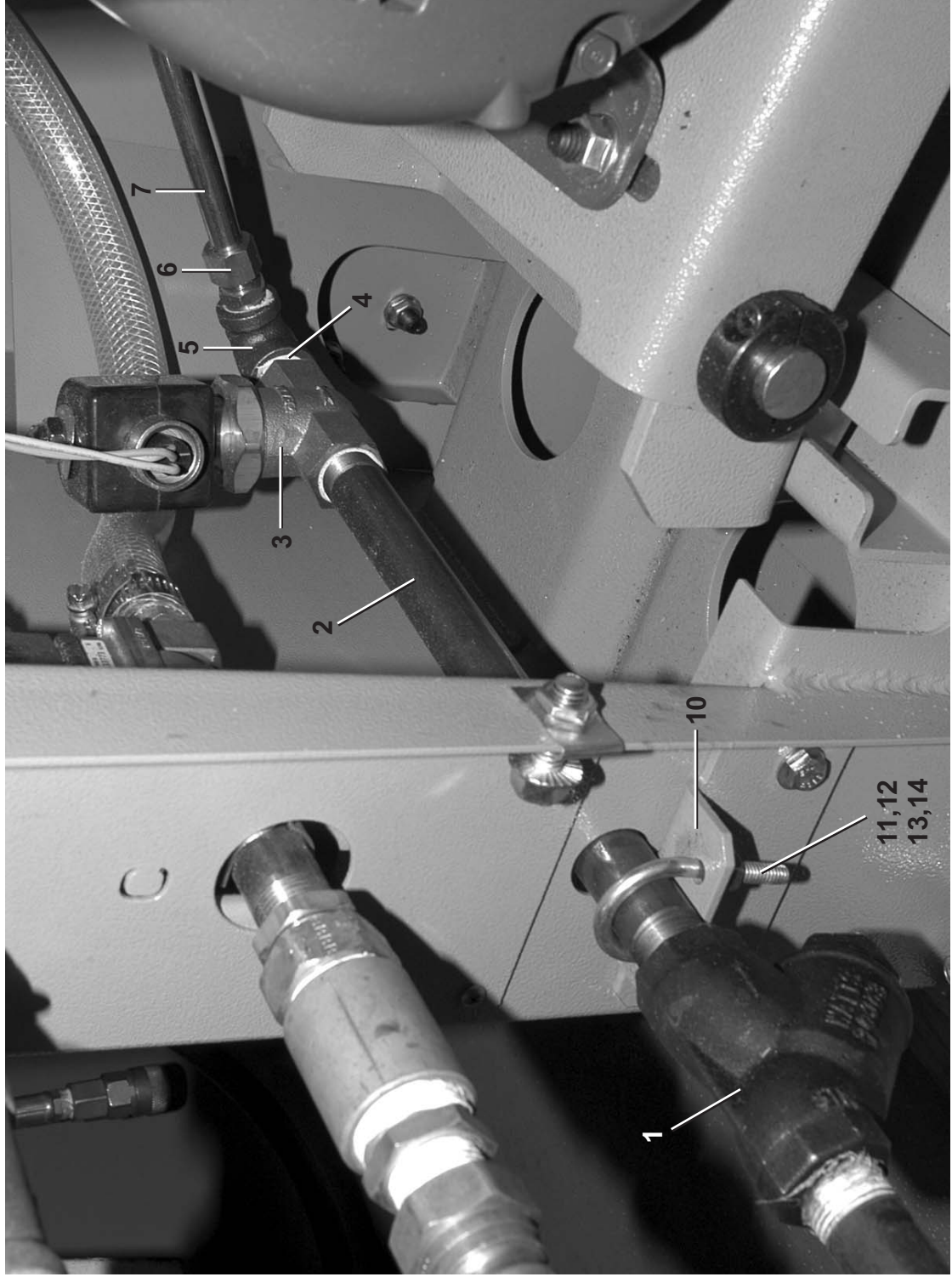



Pellerin Milnor Corporation
P. O. Box 400, Kenner, LA 70063-0400

Litho in U.S.A.

Parts List—Steam Inlet

Find the correct assembly first, then find the needed components. The item letters (A, B, C, etc.) assigned to assemblies are referred to in the "Used In" column to identify which components belong to an assembly. The item numbers (1, 2, 3, etc.) assigned to components relate the parts list to the illustration.

Used In	Item	Part Number	Description	Comments
			-----ASSEMBLIES-----	
	A	A33 10500G	STEAM INSTAL=3015/22V REAR H20	
			-----COMPONENTS-----	
all	1	51T025	Y-STRAINER 1/2" CAST IRON	
all	2	5N0K11AF42	NPT NIP 1/2X11 TBE BLKSTL SK40	
all	3	96P039A71	1/2"STEAMVAL240V50/60C 150PSI	
all	4	5N0KCLSF42	NPT NIP 1/2XCLS TBE BLKSTL S40	
all	5	5SL0KFA0G	NPTELB 90DEG 1/2 X 3/8 BLKSTL	
all	6	53A025	MALECON.5X3/8COMP PH#68C-8-6	
all	7	02 03607	3015/22 V STEAM INLET TUBE	
all	8	5SCC0GSF	NPT COUP 3/8 SS304 150#	
all	9	W2 02555	NOZZLE=STEAM INJECTION	
all	10	02 04199	BRKT=STEAM INJ INSTL, 3022H7	
all	11	27A030A	UBOLT 1/2 PIPE 1/4-20 THD	
all	12	15U185	FLATWASHER(USS STD) 1/4" ZNC P	
all	13	15U180	LOCKWASHER MEDIUM 1/4 ZINCPL	
all	14	15G165	HXNUT 1/4-20UNC2BSAE ZC GR2	

Drain Sump Installation
3010 G5E,G5X,CGE; 3015G5E,G5X,CGE
30015, 30022Vxx, Txx, C4A, C4T, C4E; 30015, 30020, 30022Qxx

BMP920014/2004055V
 (Sheet 1 of 1)



Pellerin Milnor Corporation
 P. O. Box 400, Kenner, LA 70063-0400

Litho in U.S.A.

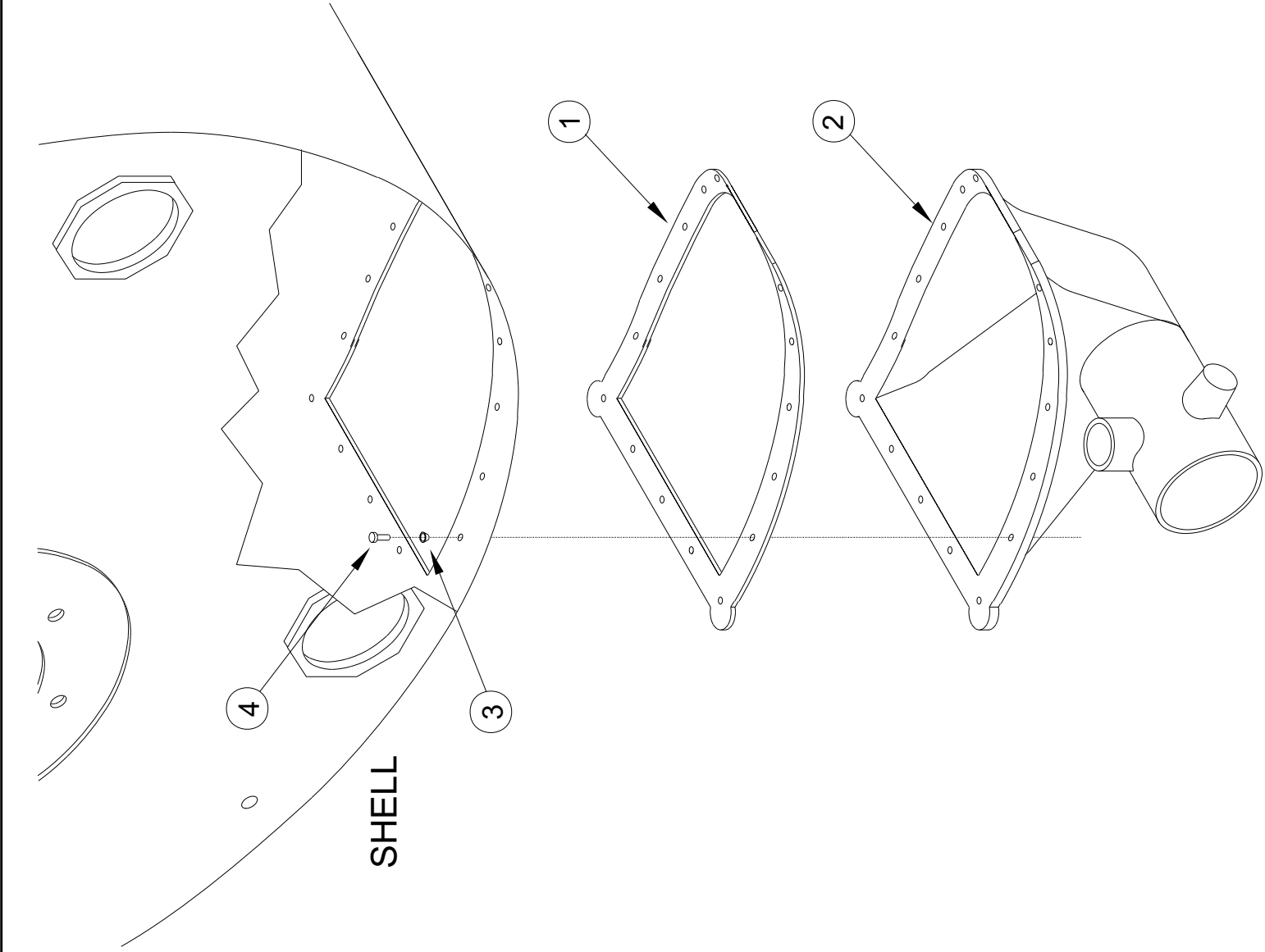

Parts List—Drain Sump Installation

Find the correct assembly first, then find the needed components. The item letters (A, B, C, etc.) assigned to assemblies are referred to in the "Used In" column to identify which components belong to an assembly. The item numbers (1, 2, 3, etc.) assigned to components relate the parts list to the illustration.

Used In	Item	Part Number	Description	Comments
			-----COMPONENTS-----	
all	1	02 03366A	DRAIN SUMP GASKET 1/8"EPDM	
all	2	02 03332A	BODY=SUMP-1608 GLASTIC	
all	3	24G018N	ROLLED WASH:194ID NYLTITE 10W	
all	4	15P050	PHDCUT-F PANHD 10-32X3/4 SS410	

DrainValve Installation

30015, 30020 & 30022 Rigid Mount Washer Extractors

BMP920020/2001036V
(Sheet 1 of 2)



Pellerin Milnor Corporation
P. O. Box 400, Kenner, LA 70063-0400

Litho in U.S.A.

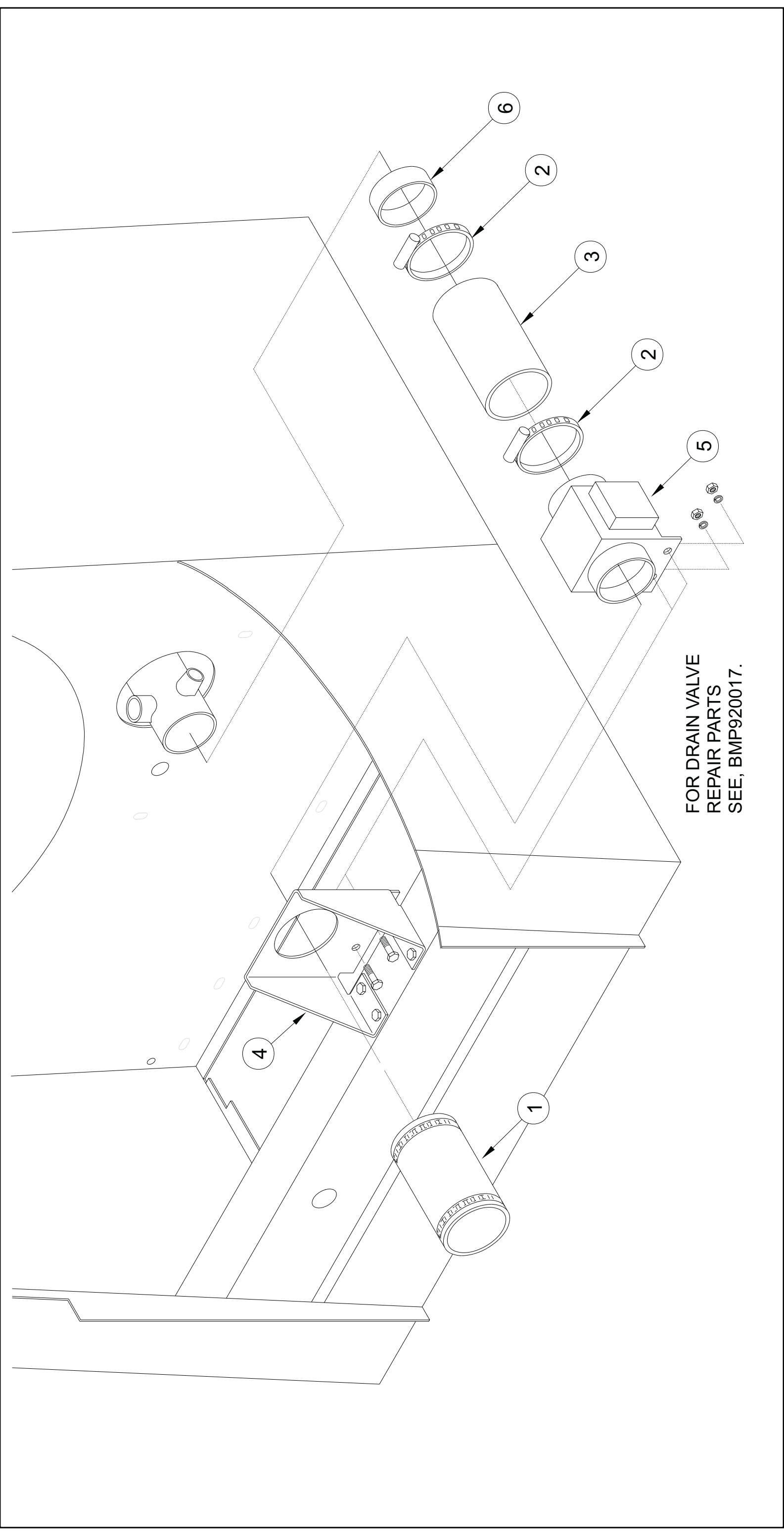



Pellerin Milnor Corporation
P. O. Box 400, Kenner, LA 70063-0400

Litho in U.S.A.

Parts List—Drain Valve Installation

Find the correct assembly first, then find the needed components. The item letters (A, B, C, etc.) assigned to assemblies are referred to in the "Used In" column to identify which components belong to an assembly. The item numbers (1, 2, 3, etc.) assigned to components relate the parts list to the illustration.

Used In	Item	Part Number	Description	Comments
			-----ASSEMBLIES-----	
	A	AD-33-011S	FLL TUBE & DRAIN ASSY 240V 30V	
			-----COMPONENTS-----	
all	1	60B075	DFW56-33PMSP RUBB CONN.	
all	2	27A082	HOSECLAMP 2.5625-3.5CADSC#HS48	
all	3	60E303A07A	HOSE=3"ID X 7" LG.	
all	4	02 03412	BRKT=DEPEND-O DUMPVAL MTG	
all	5	96D350A71	DRINVAL 3"MTRDR 240V 50/60C	
all	6	02 03412S	SLEEVE=DUMPVALVE HOSE	

3" Electric Drain Valve

BMP920017/2006214B
(Sheet 1 of 2)



Pellerin Milnor Corporation
P. O. Box 400, Kenner, LA 70063-0400

Litho in U.S.A.

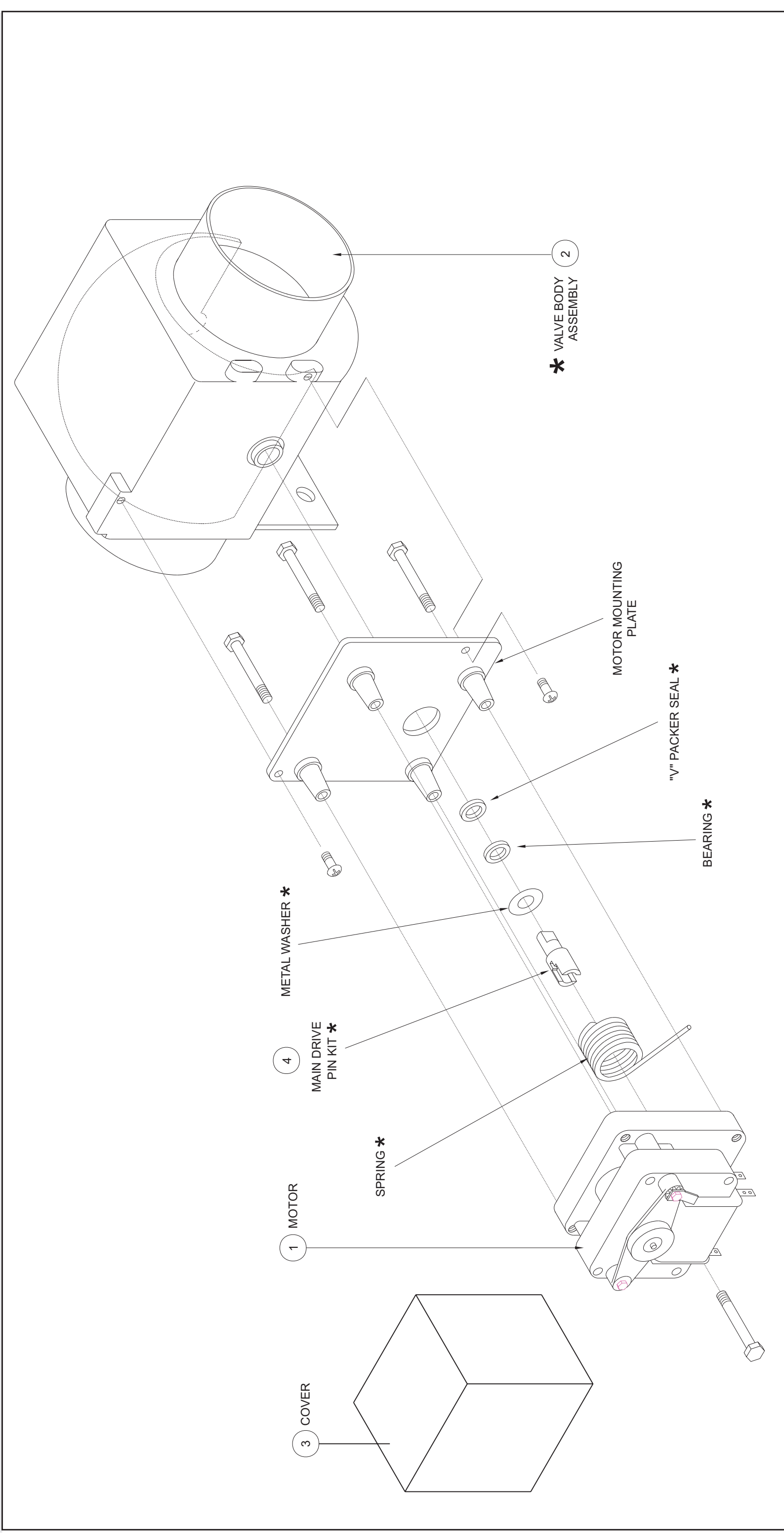



Pellerin Milnor Corporation
P. O. Box 400, Kenner, LA 70063-0400

Litho in U.S.A.

Parts List—3” Electric Drain Valve

Find the correct assembly first, then find the needed components. The item letters (A, B, C, etc.) assigned to assemblies are referred to in the "Used In" column to identify which components belong to an assembly. The item numbers (1, 2, 3, etc.) assigned to components relate the parts list to the illustration.

Used In	Item	Part Number	Description	Comments
-----ASSEMBLIES-----				
	A	96D350A37	DRINVAL 3"N/O MTRDR120V 50/60C	
	B	96D350A71	DRINVAL 3"N/O MTRDR240V 50/60C	
	C	96D350B71	DRINVAL 3"N/C MTRDR240V 50/60	
-----COMPONENTS-----				
A	1	96D35MTR37	120V 50/60CMTR FOR 3"DRAINVAL	
B	1	96D35MTR71	240V 50/60CMTR FOR 3"DRAINVAL	
all	2	96D35B0D	BODY & BALL FOR 3" DRAIN VALVE	
all	3	96D35C0V	MTRCOVER 2-PCFOR 3"DRAINVAL	
A,B	4	96D35PIN	DRIVE PIN KIT FOR 3" DRAIN VAL	

Section

7

**Control and Sensing
Assemblies**

VIBRATION SAFETY SWITCH ADJUSTMENTS

B What the Vibration Safety Switch Does

The *vibration safety switch* pictured below is an important safety feature. If properly adjusted, the switch will momentarily actuate as a result of repeated machine movement caused by an out-of-balance condition. Table A below illustrates the effect of the *vibration safety switch* actuation.

Table A—Effect of Tripping Vibration Safety Switch

Machine Model	Function of Vibration Safety Switch
30015, 30020, and 30022	Disables high speed extract
All microprocessor-controlled washer-extractors not listed above, and all dye machines	De-energizes three-wire relay, effectively terminating machine operation

Adjustments

When the machine leaves Milnor[®], the actuator arm is tie-wrapped to prevent damage (except on 30015, 30020, and 30022 models). **This tie wrap must be removed after the machine is set into position but before the machine is operated.**

Adjustment of this switch from the factory setting is not recommended; however, it should be checked for proper functioning and adjusted if its proper setting is lost.

As shown at right in FIGURE 1, the unit consists of a *sensitive micro-switch* with an extended actuating arm supporting an eccentric weight. The weight may be adjusted by moving it up and down on the arm and by rotating it on the arm. In addition, the *micro-switch* itself may be tilted from side to side.

The sensitivity of the switch increases as the eccentricweight is raised on the actuating arm and decreases as the weight is lowered.

The unit should be adjusted so that the actuating arm will always reset by itself, this being accomplished by rotating either the switch or the weight to give just enough bias to cause the switch to reset. Check the adjustment by moving the arm to the left then slowly releasing it. Make sure the micro-switch clicks when the arm is **slowly** released, thus indicating

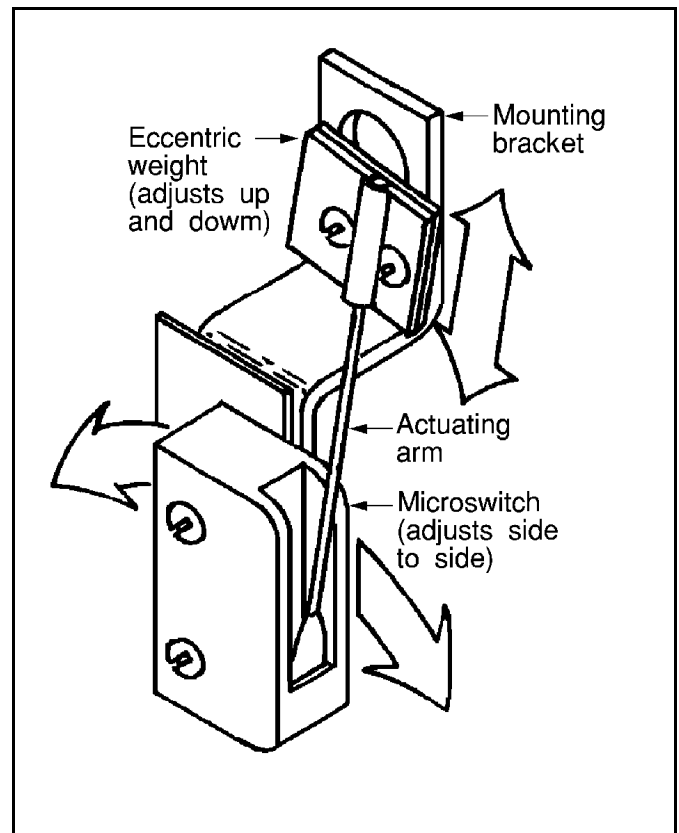

FIGURE 1 (MSSMA408BE)
Vibration Switch

that it has reset. In the released position the arm should rest **lightly** but definitely against the stop on the *micro-switch* case that prevents any further arm movement to the left.

For machines with rigid mounted shells, where the machine is bolted to a very substantial foundation, very little machine movement will occur for a given degree of out-of-balance. Under such conditions it may be better to adjust the switch to be very sensitive. With less substantial foundations (e.g., ones where the sub-soil is mushy or springy or otherwise not as desirable), considerably greater machine movement will occur for a given degree of out-of-balance, in which case a less sensitive *vibration switch* setting may be indicated.

Vibration Safety Switch

BMP910038/2007086B
(Sheet 1 of 1)



Pellerin Milnor Corporation
P. O. Box 400, Kenner, LA 70063-0400

Litho in U.S.A.

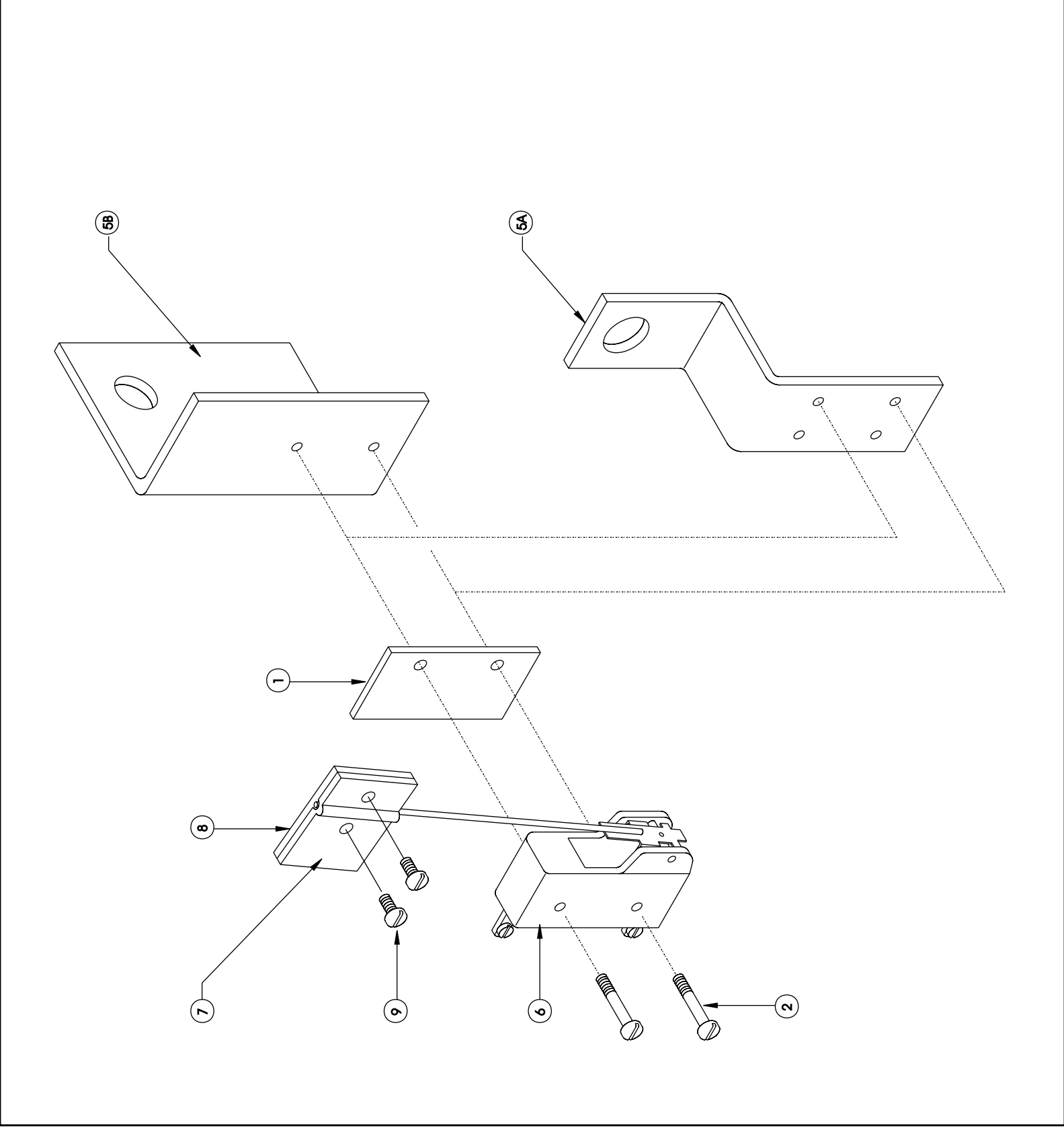

Parts List—Vibration Safety Switch
Find the correct assembly first, then find the needed components. The item letters (A, B, C, etc.) assigned to assemblies are referred to in the "Used In" column to identify which components belong to an assembly. The item numbers (1, 2, 3, etc.) assigned to components relate the parts list to the illustration.

Used In	Item	Part Number	Description	Comments
-----ASSEMBLIES-----				
A		SAE03 151	* ASSY-VIBRATION SWT=LG CONTR	(ALL MODELS EXCEPT BWP,CPE) 3015/22 V/T/G/F 3022F,362F, 4232F 3626,4226, 4230VXX 3022X,3626X,4226X,4232X 4244, 6044,7244WP/SP CONTAINS 001,002, 005A-009 (MODELS 3621BWP,CPE ONLY) CONTAINS 001,002, 005B-009
B		SAE03 151A	*ASSY-VIBRATION SWT=BALCOM	
-----COMPONENTS-----				
all	1	02 02038	PLATE INSULATING SMALL9NOV51	
all	2	15P008	TRDCUT PANHD 6-32X1 NIKSTL +WA	
A	5	02 15119	BRACKET=VIBSW CAD	
B	5	02 10264	BRACKET=SAFESW CAD	
all	6	09R020	SWITCH NC VIBR#WZ-2RW84429-P52	
all	7	03 01059	VIBSWITCH CLAMP CADSTL	
all	8	03 01058	VIBSWITCH WEIGHT-CADSTL	
all	9	15P101	TRDCUT-F PANHD 8-32X3/8 NIKSTL	